

Agency: Commerce, Community and Economic Development**Grants to Named Recipients (AS 37.05.316)****Grant Recipient: Southeast Alaska Independent Living****Federal Tax ID: 92-0144370****Project Title:****Project Type: Equipment and Materials**

Southeast Alaska Independent Living - Adaptive Vehicle

State Funding Requested: \$13,533**House District: Juneau Areawide (3-4)**

One-Time Need

Brief Project Description:

Funding for the 20% match required for ADOT&PF Coordinated Transportation grant to replace the SAIL adaptive recreation vehicle.
--

Funding Plan:

Total Project Cost:	\$81,200
Funding Already Secured:	(\$0)
FY2012 State Funding Request:	(\$13,533)
Project Deficit:	\$67,667

Funding Details:

Alaska Transit Office, The Alaska Dept. of Transportation and Public Facilities State FY2012 Replacement Vehicle & Equipment Human Services Grant provides 80% funding. This would be the sixth successful grant application SAIL has submitted to this entity.

Detailed Project Description and Justification:

SAIL is requesting the 20% match needed for an Alaska Department of Transportation & Public Facilities grant to replace our 4x4 ADA compliant 15-passenger cutaway bus with two wheel chair stations. The vehicle is used by SAIL's Outdoor Recreation and Community Access (ORCA) program to provide door-to-door transportation for seniors and people with disabilities who use the program to access the community. This vehicle will also be used to provide coordinated rides. ORCA provides the ADA rides for the City and Borough of Juneau (CBJ) owned Eaglecrest Ski Area; Juneau Alliance for Mental Health Inc. (JAMHI) and as a backup vehicle for REACH's Sunshine Coach. This project has been ranked as the top priority for equipment by the Juneau Coordinated Transportation Coalition (JCTC) and the City and CBJ Assembly.

Project Timeline:

ADOT&PF grant application submitted 2-11-11.
Grant awards April 2011.
Order vehicle within a week of Governor signing budget in June 2011.
Six months until delivery (approximately January 2012)
Full expenditure of this award anticipated January 2012.

Entity Responsible for the Ongoing Operation and Maintenance of this Project:

SAIL

Grant Recipient Contact Information:

Name:	Joan O'Keefe
Title:	Executive Director
Address:	3225 Hospital Drive, Suite 300 Juneau, Alaska 99801
Phone Number:	(907)586-4920
Email:	jokeefe@sailinc.org

Has this project been through a public review process at the local level and is it a community priority? Yes No

<i>For use by Co-chair Staff Only:</i>
10:28 AM 5/27/2011

Presented by: The Manager
Introduced: 02/07/2011
Drafted by: J.W. Hartle

RESOLUTION OF THE CITY AND BOROUGH OF JUNEAU, ALASKA

Serial No. 2559

A Resolution Expressing Assembly Support for the Juneau Coordinated Transportation Coalition's 2011 Addendum to the 2008 Transit Development Plan, Coordinated Human Services Element, to Be Submitted to the State of Alaska Department of Transportation.

WHEREAS, transportation appropriation legislation adopted by Congress in 2005, the Safe, Accountable, Flexible, Efficient Transportation Equity Act: A Legacy for Users (SAFETEA-LU), requires that each community develop a Public Transit / Human Services Community Coordination Plan to identify needs, available services, and gaps in services to target populations, and lay out strategies to address those gaps in transportation services for those who are elderly, have disabilities, or are low income traveling to work; and

WHEREAS, the City and Borough's 2008 Transit Development Plan: Coordinated Human Services Element, addresses many, but not all, of the federal requirements to maintain funding eligibility; and

WHEREAS, the Job Access and Reverse Commute Program provides capital and operating funding for services to improve access to jobs for low income persons; and

WHEREAS, the New Freedom Program provides capital and operating funding for transit and paratransit services and improvements for persons with disabilities that are new and go beyond those required by the Americans with Disabilities Act; and

WHEREAS, the Elderly Persons and Persons with Disabilities Program provides capital assistance funding to provide transit and purchase of services to private nonprofit agencies, federally recognized tribes, and qualifying local public bodies that provide specialized transportation services to elderly persons, and to persons with disabilities; and

WHEREAS, the Juneau Coordinated Transportation Coalition's 2011 Addendum to the CBJ 2008 Transit Development Plan: Coordinated Human Services Element, included here as Attachment A, addresses these gaps in order to fully qualify for the

State Department of Transportation and Public Facilities, Alaska Community Transportation grants; and

WHEREAS, at its meeting on January 6, 2011, the Juneau Coordinated Transportation Coalition met and requested that the Assembly endorse the 2011 Addendum to the 2008 Transit Development Plan: Coordinated Human Services Element; and

WHEREAS, at its meeting on January 31, 2011, the Public Works and Facilities Committee recommended that the Assembly endorse the 2011 Addendum to the 2008 Transit Development Plan: Coordinated Human Services Element, to allow member agencies to qualify for grant funding, and recommended forwarding a resolution to the Assembly for approval.

NOW, THEREFORE, BE IT RESOLVED BY THE ASSEMBLY OF THE CITY AND BOROUGH OF JUNEAU, ALASKA:

Section 1. That the Assembly supports and endorses the Juneau Coordinated Transportation Coalition's 2011 Addendum to the CBJ 2008 Transit Development Plan: Coordinated Human Services Element.

Section 2. Effective Date. This resolution shall be effective immediately upon adoption.

Adopted this 7th day of February, 2011.

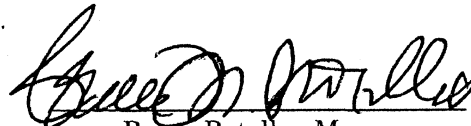
Bruce Botelho, Mayor

Attest:

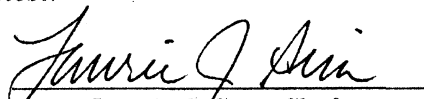
Laurie J. Sica, Clerk



JEDC.ORG
612 WEST
WILLOUGHBY
AVENUE, SUITE A
JUNEAU, AK 99801
PHONE 907-523-
2300

January 25, 2011

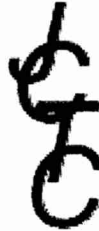

**Juneau Coordinated Transportation Coalition
Addendum 1: Prioritized Projects, 2011**

Please accept this 2011 Addendum to the CBJ 2008 Transit Development Plan: Coordinated Human Services Element.

The Juneau Coordinated Transportation Coalition (JCTC) met on January 5th, 2011 to review and prioritize all proposals for submission in the FY11 Alaska Department of Transportation and Public Facilities (ADOT& PF) Coordinated Transportation Grant projects. JCTC would like to amend the adopted 2010 priorities.

Equipment Grant: JCTC voted by unanimous consent to endorse the Southeast Alaska Independent Living (SAIL) proposal for replacement of the Outdoor Recreation and Community Access (ORCA) 4x4 cutaway bus as the top priority for this round of ADOT&PF equipment grants.

Mobility Manger Grant: At the same meeting, JCTC articulated that it's number one priority for the mobility management grant is the City and Borough of Juneau's DOT Mobility Management Grant application fund a Transportation Development Management position to serve as CBJ's representative to local, regional and state transportation agencies and support implementation of Juneau's transportation plans and polities.



Quality Community Mental Health Services Since 1985

*"We help adults with mental
illness live their own best lives"*

February 8, 2011

To Whom it May Concern:

It is my pleasure to write this letter of support for Southeast Alaska Independent Living (SAIL) regarding their grant application to ADOT&PF the ORCA bus used to transport disabled individuals for recreational and other activities. Juneau Alliance for Mental Health, Inc. (JAMHI), Juneau's Community Mental Health Center, contracts with SAIL to provide recreational activities for many of our group home residents who are adults with Serious Mental Illness, co-occurring disorders, and in some instances physical disabilities which require accessible transportation.

Our experience with SAIL and the ORCA program has been very positive and we believe that to ensure safety and reliability of transportation for the high needs population they serve, it is essential that they have an appropriately fitted vehicle. The attached MOA reflects our ongoing commitment to SAIL and the ORCA program.

Sincerely,

Pamela Watts
Executive Director

Memorandum of Agreement

Southeast Alaska Independent Living (SAIL) Inc. has been providing American's with Disability (ADA) compliant transportation for skiers and snowboarders to the Eaglecrest Ski Area for more than a decade.

SAIL is applying for a grant from the Alaska Department of Transportation and Public Facilities for a replacement 4x4 cut-a-way bus with a lift and two wheel chair stations.

SAIL agrees to continue to provide ADA compliant transportation for skiers and snowboarders to the Eaglecrest Ski Area with the new vehicle until which time the service is no longer needed or by mutual agreement of both parties.

Kirk Duncan, General Manager



2-8-2011

Printed name and signature

Date

Authorized Eaglecrest Ski Area Representative

JOAN O'KEEFE



2-9-11

Printed name and signature

Date

Authorized SAIL Representative

Memorandum of Agreement

Southeast Alaska Independent Living (SAIL) Inc. has been providing American's with Disability (ADA) compliant transportation in our 14-passenger bus for Juneau Alliance for Mental Health Inc. (JAMHI) clients to access the community more than a decade.

SAIL is applying for a grant from the Alaska Department of Transportation and Public Facilities for a replacement 4x4 cut-a-way bus with a lift and two wheel chair stations.

SAIL agrees to continue to provide ADA compliant transportation for JAMHI consumers with the new vehicle until which time the service is no longer needed or by mutual agreement of both parties.

Pamela L Watts Pamela Watts
Printed name and signature
Authorized JAMHI Representative

2-8-11
Date

J Allen
Printed name and signature
Authorized SAIL Representative

2-9-11
Date

Memorandum of Agreement

Southeast Alaska Independent Living (SAIL) Inc. has been providing American's with Disability (ADA) compliant transportation in our 14-passenger bus for mutual consumers of REACH and SAIL to access the community since the inception of SAIL's adaptive and inclusive recreation program, ORCA, some fifteen years ago.

Both REACH and SAIL are founding members of the Juneau Coordinated Transportation Coalition (JCTC). The JCTC was formed in 2005. Both agencies have demonstrated a strong commitment to coordinated transportation to better the lives of our consumers and the larger community.

SAIL is applying for a grant from the Alaska Department of Transportation and Public Facilities for a replacement 4x4 cut-a-way bus with a lift and two wheel chair stations.

SAIL agrees to continue to provide ADA compliant transportation for mutual SAIL and REACH consumers for adaptive and inclusive recreation with the replacement vehicle requested, should it be funded.

In addition, and in the spirit of coordination and collaboration, SAIL agrees the replacement vehicle will serve as a backup vehicle should the REACH Sunshine Coach be incapacitated or otherwise unavailable for REACH client transport.

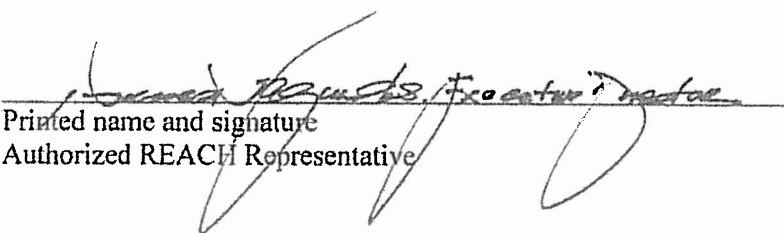
Printed name and signature
Authorized REACH Representative

2/9/11
Date

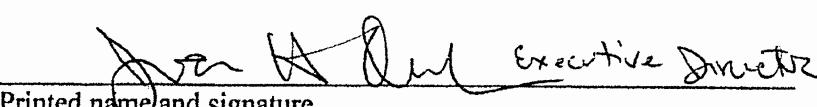
Printed name and signature
Authorized SAIL Representative

2/9/11
Date



SCHETKY NORTHWEST SALES, INC.

PROVIDING TRANSPORTATION SOLUTIONS SINCE 1942!

Proudly Representing:

- ElDorado National
- Elkhart Coach
- Champion Bus
- General Coach
- Starcraft Bus
- Thomas Built Bus
- Midway Specialty Vehicle

February 24, 2011

Ms. Joan Herbage O'Keefe
Executive Director
Southeast Alaska Independent Living
3225 Hospital Dr.
Suite 300
Juneau, AK 99801

Re: ElDorado National Aerotech 220

Dear Ms. O'Keefe:

As you are aware, Schetky Northwest Sales, Inc. holds a contract with the State of Alaska Department of Transportation for the supply of standard body light duty cutaway style buses, which your recent capital request would qualify for.

You had indicated a need for a light-duty cutaway style vehicle that was compliant with the provision of the Americans With Disabilities Act while maintaining a passenger capacity below the Commercial Driver License (CDL) threshold which is fourteen (14) passengers or less. You also indicated that the vehicle needs to be equipped with a 4-wheel drive feature and other features for operation in Alaska. Recognizing these features, I had recommended a budgetary amount of \$80,000.00 per vehicle not knowing when you would be in a position to order. For your review I've attached a copy of a similar quote for like-type equipment that we have produced for the Native Village of Point Hope. This vehicle was ordered by Point Hope in November of 2009 for a purchase price of \$74,297.00 FOB Port of Tacoma/Seattle. Barge delivery to Juneau would be approximately \$3,000.00 additional. We have also had two (2) model year changes since the time of this quote. Given the chassis model year increases and shipping to Juneau, I feel that an \$80,000.00 per vehicle budget reasonable. I have also attached photos of this 4-wheel drive vehicle so that you can see what the finished vehicle would look like.

I hope this information meets your needs. We value your business and welcome the opportunity to be of service to you. Please do not hesitate to call me should you have any questions or whenever I can be of assistance.

Most Sincerely,

Bob Petrovski
Manager, Bus Division

8430 NE Killingsworth St. • Portland • Oregon • 97220
{800} 255-8341 • Direct {503} 382-3114 • Wireless {360-609-8000} • FAX {503} 287-2931
e-mail: bobp@schetkynw.com • www.schetkynw.com



CHETKY NORTHWEST SALES, INC.

8430 N.E. Killingsworth St. . Portland, Oregon 97220
800-255-8341 Telephone 503-287-4141 FAX 503-287-2931

23-Nov-09

STATE OF ALASKA PRICE AGREEMENT #1430, LOT #2

PURCHASING AGENCY: NATIVE VILLAGE OF POINT HOPE

ITEM 1.

BASE VEHICLE (ELDORADO NATIONAL AEROTECH 200)

\$51,574.00



AEROTECH – AMERICA'S #1 CHOICE SINCE 1985!

STANDARD FEATURES:

MODEL

2009 AEROTECH 220 (FORD),

CHASSIS

2009 E450 FORD

LIMITED SLIP DIFFERENTIAL

CHASSIS MODIFICATIONS

SPRING SPACER, LIFT SIDE (E450)

EXHAUST OPTION, 3" STREET SIDE' 45 DEGREE

FUEL SENDER ACCESS PLATE, DIAMOND PLATE

FAST IDLE, GATEWAY FORD DSL/GAS WITH ILIS CONTROLLER

BUMPER, REAR HELP

FLOORING , TO BE CL BUS PAEL FLOORING AS OPTION PRICING

FLOORING, 3/4" MARINE PLYWOOD SUBFLOORING

RUSTPROOFING, (ZINC CHROMATE)

RUSPTROOFING, WAXOLY

DOORS

DOOR, ENTRY A&M 30 ELECTRICAL

DOOR OPTION, EXTERIOR KEY SWITCH

LIGHT, EXTERIOR ENTRY DOOR LIGHT

W/C DOOR LIFT, AEROTECH STD FLR RR

W/C DOOR LIFT, AEROTECH (STD) STANDARD FLOOR

WINDOWS

WINDOW PACKAGE, 41H X 29W (NEW BODY)

ALTERNATOR BATTERY

LIGHT, 3 EXIT (INTERIOR) LED RED

HEATING

HEATER, 65K BTU (PROAIR 465)

HEATER HOSE INSULATION, THERMACELL

HEATER BOOSTER PUMP

HEATER, STEPWELL ELECTRIC

DRIVER CONTROLLED WITH ON/OFF SWITCH

ELECTRICAL, EXTERIOR

BATTERY TRAY, M/R SEAL-TITE, 3B

BATTERY DISCONNECT

INSTALL IN DRIVER STEPWELL

JUMPSTART, GOODALL UNDERHOOD

EXTERIOR LED LIGHT PACKAGE

ELECTRICAL - INTERIOR

RADIO, AM/FM/CD FORD

DRIVERS FAN

INSTALL INTERIOR CURB SIDE

FEATURES, EXTERIOR

BUMPER, HELP FRONT

STAINLESS STEEL SCREWS, INTERIOR

RUBRAILS

CAB UNDERCOATING

DRIPRAIL OPTION, ALUMINUM

SPARE TIRE, SHIP LOOSE

SAFETY - EXTERIOR

REVERSE ALARM

TRANSPEC LOW PROFILE 24 x 24 HATCH

MIRROR, HEATED FORD, BRKAWAY M/L

ON/OFF SWITCH WITH AMBER INDICATOR LIGHT

MIRROR, CROSSOVER/ 8" CONVEX

MUST BE 10-INCHES.POWDER COATED OR SS.

INSTALL UPPER LEFT EXTERIOR REAR

FEATURES, INTERIOR

CABLINER WITH STORAGE, LOCKING

STANCHION, VERTICAL WITH MODESTY PANEL

FORWARD OF LIFT

HANDRAIL, RIGHT ENTRY ASSIST

SUNVISOR, PADDED

INSTALL ON CURB SIDE

FLOOR RUBBER, RS GRAY

COVE MOLDING, RUBBER TO SEAT RAIL

MODESTY PANEL, DRIVER

SAFETY - Interior

MIRROR,6" x 16" INTERIOR

5# FIRE EXTINGUISHER

TRIANGLE REFLECTOR KIT

SEATING

SEAT, MID-BACK DOUBLE FREEDMAN (6)

SEATING ACCESSORIES

SEAT ARMREST, US ARM (QTY 6)
SEATBELT, 74" STD (12)
SEAT GRAB HANDLE, PADDED (12)

DRIVER'S SEAT AND ACESSORIES

FREEDMAN FSC FORD HIGH BACK RECLINER

PARATRANSIT

LIFT DOOR AJAR BUZZER
LIFT, RICON S5010 FRT 34" x 54", 403/404
LIFT, CIRCUIT BREAKER TO BE IN BATT. COMPARTMENT
STORAGE BAG, TIEDOWN (SURE-LOK)
EXTENSION, 12" SEATBELT
EXTENSION, 30" SEATBELT
DECALS, ADA SPEC
L TRACK, FULL LENGTH (2)
 INSIDE TRACKS TO BE ON 15 : CENTERS
 OUTSIDE TRACKS TO BE ON 28" CENTERS
LIGHT, LIFT EXTERIOR ADA
LIGHT, LIFT INTERIOR
SURE-LOK RETRAKTOR SECUREMENT SYSTEM (QTY 2)
 SURE-LOK 627S4 RESTRAINTS, SURE-LOK FE627S-RC QTY 2
 NON-RETRACTABLE, CLOSED HOOD QTY 2
 D-RING END FITTING
 RESTRAINT, SURE-LOK INTEGRATED LAP BELT QTY 2
 RST, SURE-LOK REST. SIRE-LOK NON-RETRACTTABLE SHOULDER HARNESS

PAINT

INTERIOR, POWDER COAT. YELLOW
DECALS CUSTOM - NO SMOKING
DECALS TO BE ENGRAVED ON PLASTIC LAMINATE

OTHER

MANUALS, CD CUSTOEMR PARTS/ELECTRIC/OPERATOR TRAINING VIDEO
CERTIFIED WEIGHT SLIP
RICON OWNER/OPERATOR MANUAL
50 BELOW ZERO ANTIFREEZE
SUR-LOK SEAT BELT CUTTER
POWER FLARE PF-200 KIT
STATE OF AK DECALS
RUBBERMAID STORAGE BOX

AVAILABLE OEM CHASSIS OPTIONS: (MAY EXTEND LEAD TIME)		PRICE	EXT.
1	SIX-WAY POWER DRIVER SEAT & PEDESTAL	\$ 630.00	\$ 630.00
	OEM CRUISE CONTROL	\$ 195.00	\$ -
	OEM POWER STEERING COOLER	\$ 75.00	\$ -
1	OEM CHASSIS SHOP MANUALS	\$ 480.00	\$ 480.00
	OEM AM/FM RADIO	\$ 240.00	\$ -
	OEM AM/FM/CASS RADIO	\$ 300.00	\$ -
	OEM AM/FM/CD RADIO	\$ 420.00	\$ -
1	LIMITED SLIP DIFFERENTIAL	\$ 360.00	\$ 360.00
	DUAL 110 AMP ALTERNATORS (DIESEL ONLY)	\$ 720.00	\$ -

MITSUBISHI 200 AMP ALTERNATOR	\$	900.00	\$	-
TOTAL CHASSIS OPTIONS			\$	1,470.00

SCHEDULED OPTIONS:		PRICE	EXT.
	2B DIESEL ENGINE IN LIEU OF GAS	\$ 5,495.00	\$ -
1	2C SILICONE PAD HEATERS AND ELECTRIC CORD	\$ 293.00	\$ 293.00
1	2D QUIGLEY 4-WHEEL DRIVE CONVERSION	\$ 12,555.00	\$ 12,555.00
	2E TIRE CHAINS, W/COMPRESSOR COMPARTMENT	\$ 2,325.00	\$ -
1	2F STEPWELL BATTERY COMPARTMENT	\$ (400.00)	\$ (400.00)
1	2G AUXILIARY HEATER - ESPAR H-5 WITH TIMER & BOX	\$ 1,640.00	\$ 1,640.00
	2H VINYL FLOOR COVERING - ALTRO META	\$ 200.00	\$ -
	2I SEATS INC. DRIVER SEAT	\$ 735.00	\$ -
	2J FREEDMAN ISC DOUBLE SEAT	\$ 905.00	\$ -
14	2K ANTI-BACTERIAL SEAT FABRIC - MORE-CARE (EACH)	\$ 25.00	\$ 350.00
	2L FREEDMAN SEAT SIDE SLIDERS EACH)	\$ 25.00	\$ -
	2M THIRD (3RD) WHEELCHAIR POSITION	\$ 701.00	\$ -
	2N FOURTH (4TH) WHEELCHAIR POSITION	\$ 1,477.00	\$ -
	2O WHEELCHAIR RESTRAINT SYSTEM (BELT KIT)	\$ 40.00	\$ -
1	2P REAR EMERGENCY DOOR	\$ 610.00	\$ 610.00
1	2Q ASTRO START REMOTE	\$ 350.00	\$ 350.00
	2R PUBLICATIONS	\$ 227.00	\$ -
1	2S FIRST AID KIT	\$ 50.00	\$ 50.00
1	2T BODY FLUID CLEAN UP KIT	\$ 40.00	\$ 40.00
1	2U MOR/RYPDE REAR SUSPENSION	\$ 1,080.00	\$ 1,080.00
	2V ENGINE HIGH IDLE SYSTEM	STD	STD
1	2W XL BUS PANELS	\$ 300.00	\$ 300.00
1	2X WHEELCHAIR LIFT WITH 32" x 51" PLATFORM	\$ 370.00	\$ 370.00
TOTAL SCHEDULED OPTIONS:			\$ 17,238.00

CUSTOMER CHOICE OPTIONS FOR CONSIDERATION		PRICE	EXT.
#1	TELMA ELECTROMAGNETIC BRAKE RETARDER	\$ 5,220.00	\$ -
6	#2 AISLE SEAT ARMRESTS (EACH)	\$ 25.00	\$ 150.00
6	#3 AV SEAT BACK GRAB HANDLES (EACH)	\$ 30.00	\$ 180.00
1	#4 TIRE CHAINS FOR REAR WHEELS	\$ 90.00	\$ 90.00
	#5 DIGITAL CLOCK IN DRIVER AREA	\$ 60.00	\$ -
1	#6 ELECTRIC ACTUATED ENTRY DOOR	\$ 390.00	\$ 390.00
	#7 36-INCH ENTRY DOOR	\$ 115.00	\$ -
1	#8 STANDEE LINE	\$ 25.00	\$ 25.00
	#9 NEXT STOP REQUEST SYSTEM	\$ 450.00	\$ -
1	#10 DAYTIME RUNNING LIGHTS	\$ 100.00	\$ 100.00
	#11 FRONT MOUNTED SPORTWORKS BIKE RACK	\$ 1,225.00	\$ -
1	#12 JACK, JACK HANDLE, & LUG WRENCH	\$ 100.00	\$ 100.00
1	#13 WIDE ANGLE LENS, REAR WINDOW	\$ 25.00	\$ 25.00
1	#14 MOBILE RADIO PREP PACKAGE	\$ 235.00	\$ 235.00
	• GROUND PLANE WITH ACCESS PANEL		
	• GROUND/POWER LEADS		
1	#15 65K EVEAPORATOR HEAT STRIP	\$ 390.00	\$ 390.00
1	#16 7" AMBER FLASHING LIGHTS, FRONT/REAR	\$ 100.00	\$ 100.00
	#17 ECHOVISION BACKUP SENSING SYSTEM	\$ 445.00	\$ -
	#18 INTERMOTIVE HAWKEYE SYSTEM W/HELP BUMPER	\$ 1,325.00	\$ -
1	#19 MAXON WL7C-34L W/C LIFT IN LIEU OF BRAUN	\$ 115.00	\$ 115.00
1	#20 HALOGEN FOG OR DRIVING LIGHTS	\$ 100.00	\$ 100.00
1	#21 SKIRT MOUNTED REAR DOCKING LIGHTS	\$ 125.00	\$ 125.00

1	#22	OVERHEAD STANDEE RAIL (EACH)	\$	115.00	\$	115.00
1	#23	DRIVER FAN	\$	65.00	\$	65.00
	#24	W/C DOOR AJAR LIGHT/BUZZER	\$	60.00	\$	-
1	#25	REAR CENTER MOUNT BRAKE LIGHT	\$	60.00	\$	60.00
	#26	LOCKING FUEL FILL COVER	\$	120.00	\$	-
1	#27	MARKER LIGHT, ARMORED LIGHT GUARDS	\$	100.00	\$	100.00
	#28	W/C HEIGHT ADJUSTABLE SHLDR RESTRAINTS	\$	60.00	\$	-
	#29	LIGHTS LED SIDE TURN ARMORED	\$	150.00	\$	-
1	#30	YELLOW STEP NOSING	\$	50.00	\$	50.00
	#31	YELLOW POWDER COATED ENTRY ASSISTS	\$	235.00	\$	-
	#32	PILLOW TOP SEAT BASE ON FIXED SEATS	\$	30.00	\$	-
1	#33	HEATER FLOW CONTROL VALVE	\$	150.00	\$	150.00
	#34	DELUXE PADDED STANCHIONS	\$	120.00	\$	-
	#35	PADDED MODESTY PANEL (EA)	\$	45.00	\$	-
1	#36	VIDEO TAPE, TIE DOWN TRAINING	\$	25.00	\$	25.00
2	#37	FREEDMAN SINGLE PX. FEATHERWEIGHT FLIP SEAT	\$	275.00	\$	550.00
1	#38	POINT HOPE NATIVE VILLAGE VINYL GRAPHICS	\$	775.00	\$	775.00

TOTAL CUSTOMER CHOICE OPTIONS:	\$ 4,015.00
---------------------------------------	--------------------

TOTAL PER VEHICLE COST, FOB: DESTINATION (OR. STATE)	\$74,297.00
---	--------------------

EXTERIOR COLOR - OEM BRIGHT WHITE

INTERIOR COLOR - OEM MEDIUM GRAY

UPHOLSTERY - MEDIUM GRAY

FLOOR COVER COLOR - BLACK

REGISTERED OWNER:

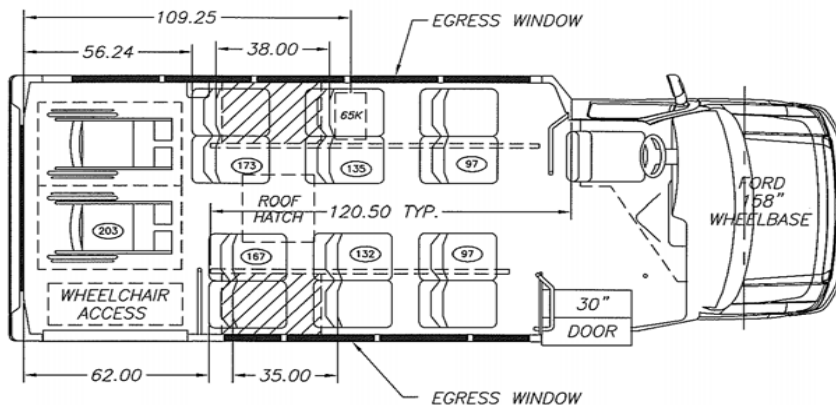

* Purchasing agency is responsible for all applicable taxes, fees and charges relating to this purchase.

* Above pricing is inclusive of all rebates and/or incentives applicable to purchase.



Native Village
of Point Hope Transit



Native Village of Point Hope Transit



907-368-2330

AEROTECH



Native Village of Point Hope Transit



907-368-2330

AEROTECH



Native Village of
907-3



 Native Village of Point Hope Transit

907-368-2330





Native Village
of Point Hope Transit

LONDON ST

Native Village of Point Hope Transit

907-686-2200