

Agency: Commerce, Community and Economic Development**Grants to Municipalities (AS 37.05.315)****Grant Recipient: Pilot Point****Federal Tax ID: 92-0140460****Project Title:****Project Type: Equipment and Materials****Pilot Point - 1st Response Fire Fighting Equipment****State Funding Requested: \$49,273****House District: 37 / S**

One-Time Need

Brief Project Description:

To provide first response firefighting equipment to the city's volunteer fire department.

Funding Plan:

Total Project Cost:	\$54,373
Funding Already Secured:	(\$5,100)
FY2015 State Funding Request:	<u>(\$49,273)</u>
Project Deficit:	\$0

Detailed Project Description and Justification:

The City of Pilot Point has 28 homes and support infrastructure that includes a school, post office, newly erected store, bulk fuel farm, city office, clinic, power plant, VPSO office and jail, a landfill, tribal office, a city shop, and cannery building that houses storage for the city and fishing community, a fire hall, a bulkhead/dock and various privately owned hangers and boat sheds. We currently do not have the capacity to make a 1st response to any type of fire. Our equipment is outdated and unreliable. The city owns a 1981 Chevy 1 ton Scottsdale fire truck. As a fire truck the water tank is nonfunctional and parts cannot be obtained. The truck however is in good working order and has a bed that will accommodate portable foam units. The city currently owns a 30 gallon Tri Max Foam unit for firefighting. This equipment was originally part of the "Code Red" van. The fire extinguishers have been used. The unit is over 8 years old. The 30 gallon unit provides 600 gallons of firefighting capabilities. We have assessed our need and we feel the minimum capacity needed for 1st response is 1800 gallons of firefighting capacity. The 1st response is always human life. We would like to purchase two more 30 gallon foam units to accompany our existing unit while utilizing our current fire truck by modifying the bed portion to accommodate all three units in one single unit. Our current heated fire bay would remain adequate to accommodate the apparatuses desired in this request. City employees will be modifying the fire truck to make these modifications to the current fire truck. The units come prefabricated and then will simply be loaded and mounted on the bed of the fire truck. Due to the remoteness of our village, we need an ability to recharge the air tanks on the units to keep them current and functional. With our request we are asking for other items that will make our volunteer fire department able to respond with the needed equipment and bring our facilities to an effective operational status. It is ordained by our municipal code that the city provide fire safety for its residents.

We are requesting the following items for this project:

(2) Tri-Max -- 30 Vertical AMB Compressed Air Foam Systems

FOB to Anchorage: \$22, 524.00

(4) Blizzard D Chemguard Freeze Protected Foam (55 gallon drum)

FOB to Anchorage \$8,200.00

(1) CGA 346 Industrial female to SCUBA Block Adaptor

FOB to Anchorage \$140.00 (1)Max Air SCBA Compressor 35 Single Phase 110V FOB to Anchorage \$4642.00 Fire Extinguishers FOB to Anchorage \$4,375.00 Ansul Fire Extinguisher Cartridges FOB to Anchorage \$1,392.00 Shipping from Anchorage to Pilot Point Hazmat FOB to Pilot Point \$8,000.00
--

Project Timeline:

As soon as funding is approved we will move forward with ordering the units and supplies and modifications will be made to the current fire truck. With shipping of hazmat materials it is anticipated that everything should be in place and functioning up to capacity within a month's time of receiving funding, placing order, receiving shipment and installation.

Entity Responsible for the Ongoing Operation and Maintenance of this Project:

City Manager

Grant Recipient Contact Information:

Name: Barbara Higgins
 Title: City Manager
 Address: P.O. Box 430
 Pilot Point, Alaska 99649
 Phone Number: (907)797-2200
 Email: bhiggins@pilotpointak.gov

Has this project been through a public review process at the local level and is it a community priority? Yes No

For use by Co-chair Staff Only:

11:56 AM 5/13/2014

City of Pilot Point
P.O. Box 430
Pilot Point, Alaska 99649

Resolution 2014-3
FY2013-2015 Capital Improvement Priority List

A RESOLUTION UPDATING THE CITY OF PILOT POINT'S CAPITAL IMPROVEMENT PRIORITY LIST IN ASSOCIATION WITH THE LAKE AND PENINSULA BOROUGH.

WHEREAS: the City of Pilot Point is incorporated as a second class city, and

WHEREAS: the city council for the City of Pilot Point would like to update the Capital Improvement Priority list in association with the Lake and Peninsula Borough for the purposes of making community improvements, and

WHEREAS: the social and economic benefits associated with the project will increase the safety, health and environment of the city and its residents, and

WHEREAS: the last update provided to the borough was December 11, 2012 by Resolution 2013-3, and

WHEREAS: the city council for the City of Pilot Point wishes to maintain an accurate record of the community's current priority for Capital improvement projects by providing an updated CIP list to the Lake and Peninsula Borough.

NOW THEREFORE BE IT RESOLVED that the City of Pilot Point has listed below the following Capital Improvement project that is of the highest priority to the city and its residents.

1. 1st Response Fire Safety Equipment

PASSED AND APPROVED by a duly constituted quorum of the City of Pilot Point city council, this 14th day of January, 2014.

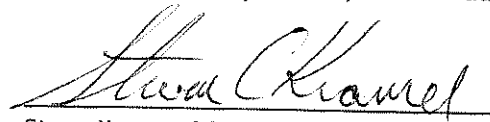
Steve Kramer Mayor

Attest:

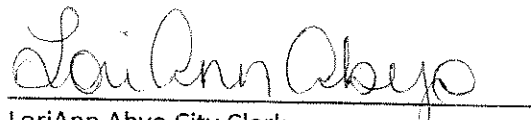
LoriAnn Abyo City Clerk





30 Vertical AMB COMPRESSED AIR FOAM SYSTEM



OPERATIONS, TRAINING, & MAINTENANCE MANUAL

January 1, 2008

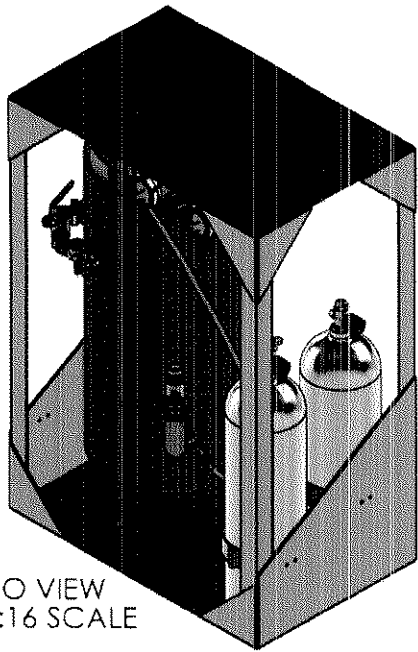

ISO VIEW
1:16 SCALE

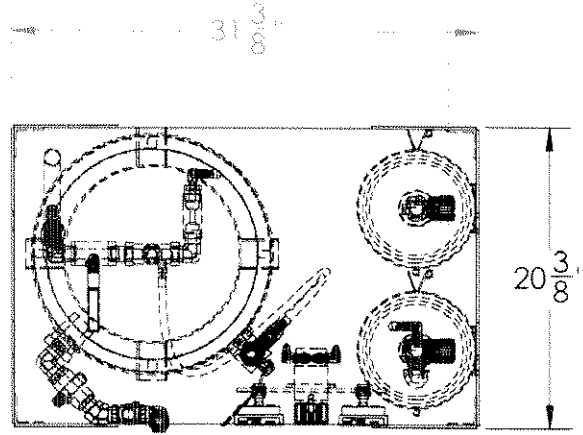

TOP

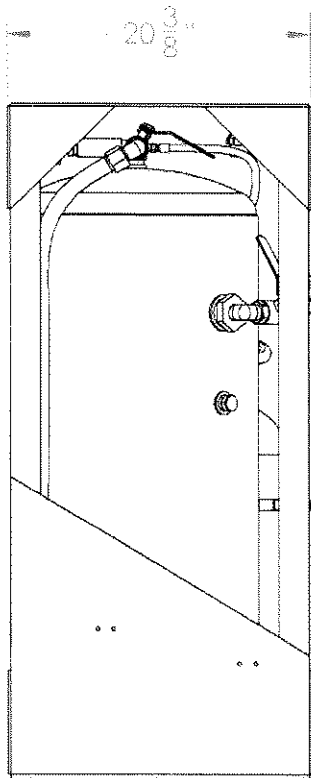

LEFT

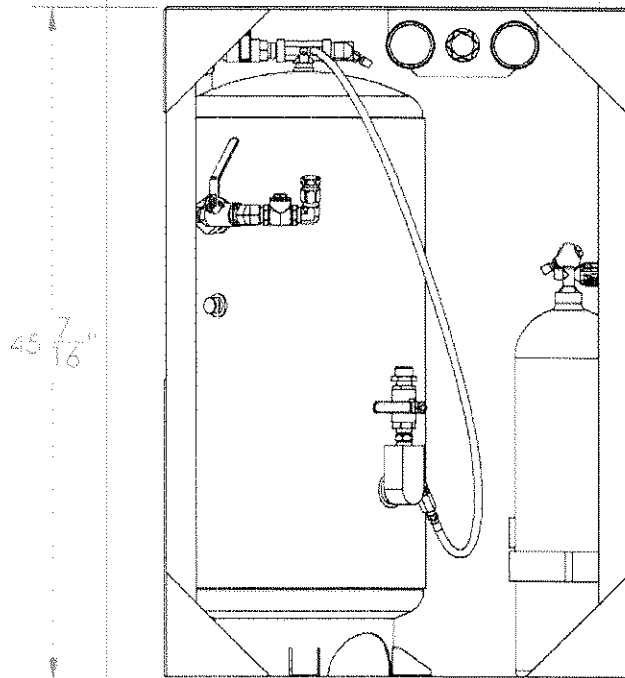

FRONT

DIMENSIONS ARE IN INCHES
TOLERANCES:
FRACTIONAL ±
ANGULAR: MACH ±
TWO PLACE DECIMAL ±
THREE PLACE DECIMAL ±

DATE	BY	APP'D	REV
1-1-2010	DJR		1
1-1-2010	AW		2

DO NOT SCALE DRAWING

PROPRIETARY AND CONFIDENTIAL

THE INFORMATION CONTAINED IN THIS DRAWING IS THE SOLE PROPERTY OF KINGSWAY INDUSTRIES, INC. AND IS NOT TO BE REPRODUCED OR TRANSMITTED IN ANY FORM OR BY ANY MEANS, WITHOUT EXPRESS WRITTEN PERMISSION OF KINGSWAY INDUSTRIES, INC.

KINGSWAY INDUSTRIES, INC.

TRI-MAX
K.I.C.A.F. FIRE TECHNOLOGIES

TM-30 VSI

A D-TM30VSI-REV2

Page 3

CLASS: 2 WBOH

DATE: 04/12

info@trimax.us

888.774.6299



[Home](#)

[About](#)

[Products](#)

[Product Support](#)

TRI-MAX 200 SUPER-CAF

Super-CAF

Cold CAF Series

The powerful Super-CAF series provides heavy-duty fire fighting capabilities wherever needed. The state-of-the-art Super-CAF units fit pick-up trucks, heavy rescue or HAZMAT vehicles and trailer mounts. Used for industrial sites, flight lines, race tracks, parking garages, marine applications, heavily populated areas or anywhere a fire truck is needed.

The Super-CAF systems are capable of having both lines discharged simultaneously, giving them the ability to attack a fire from two directions.

The TRI-MAX Super-CAF Series offers the initial response fire suppression capability of a much larger fire suppression vehicle.

- Durable welded copolymer frame
- Dual discharge capability
- No moving parts to fail
- Custom sizes available
- SKID mounted for ultimate versatility
- 200 gallons of solution provides up to 4000 gallons of finished foam product
- Single point refill port for convenient air cylinder refill

TRI-MAX
K.C.A.F. FIRE TECHNOLOGIES

Above the Best



US Forest Service



TRI-MAX Super-60 CAF
60 Gallon Super-CAF System

TRI-MAX Super-120 CAF
120 Gallon Super-CAF System

TRI-MAX Super-200 CAF
200 Gallon Super-CAF System

COMPRESSED AIR FOAM FIRE SUPPRESSION SYSTEM (CAFS)

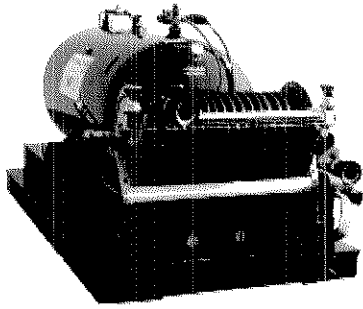

The largest of its family of large capacity SKIDS, the TRI-MAX SUPER-200 is capable of producing a staggering 4000 gallons of finished foam product.

Armed with the same Dual Discharge Capability of the other systems in the Super-SKID series the TRI-MAX SUPER-200 is a powerhouse that allows

two operators to attack a fire from two directions.

The TRI-MAX Super-200 was engineered to fit in the back of a full-size one-ton pickup truck or a trailer.

Outfitted with 100Ft of 1" Booster line and 100 ft of 1.5" collapsible hose, the TRI-MAX SUPER-200 is a powerful system in a small package.

- **Durable Welded Copolymer frame**
- **Dual Discharge Capability**
- **200 Gallons of solution provides up to 4000 gallons of finished foam product**
- **No moving parts to fail**
- **SKID mounted for ultimate versatility**
- **Single Point Refill port for convenient air cylinder re-fill**

Options & Accessories

- Available without Hose Reel
- Available in HAZMAT Configuration
- Additional 300 cu. ft Air Cylinder
- Custom Installation
- Trailer Mount Option
- Single Discharge Configuration

Specifications:

- Height: 46" Width: 47 ½" Length: 98"
- Loaded Weight: 2915 lbs. Empty Weight: 1315 lbs.
- Premix Tank: 200 gallon capacity
- Finished Foam Capacity: Approximately 4000 gallons
- Finished Foam Discharge Rate:
 - 1" hose approx. 250-300 gpm,
 - 1.5" hose approx. 450 gpm.
- Discharge Duration:
 - 1" discharge hose approx, 13 min.,

Downloads & Support Docu

[Manual](#)

[Spec & Draw](#)

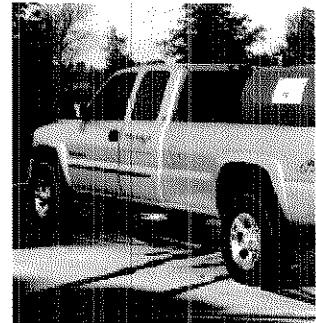

- 1.5" discharge hose approx. 8-9 min.
- Foam Discharge Distance:
 - 1" rubber booster line approx. 65-75 feet in a zero- wind condition
 - 1.5" flat lay attack hose approx. 85-95 feet in a zero-wind condition
- Air Cylinder (Industrial): Two (2) 300 CF 2250 psi
- Regulator: Adjustable pressure 0-400 psi
- Dispensing Hose: 100 feet of 1" hard rubber booster and 1.5" collapsible hose.
- Usable Hose Length: 500 plus feet per discharge side

TESTIMONIES

This memo is to appraise you of our plans to use the TRI-MAX 30 fire extinguisher system and what lead to our decision to purchase this system.

-Robert C. Wehrenberg

[Read all Testimonies »](#)

NEWS AND UPDATES

U.S. Troops Train With The TRI-MAX 30 CAF System In Afghanistan August 2, 2013

Need Equipment? NHS Firefighter Grants Available July 31, 2013

Nineteen lost too soon. July 3, 2013

Alaska Village Initiatives
 1577 C Street, Suite 304
 Anchorage, AK 99501
 1-800-478-2332

January 23, 2014

Sales Quote

Shipper	George Quinto	Consignee	Michael Veal	Payor	Michael Veal
Company	Alaska Village Initiatives	Company	City of Pilot Point	Company	City of Pilot Point
Address	1577 C Street, Ste. 304 Anchorage, AK 99501	Address		Address	
Phone	907-263-9826	Phone	797-2200	Phone	797-2200
Fax	907-263-9971	Fax		Fax	
e-mail		e-mail		e-mail	

Ship Date: TBD

Item Code	Description	QTY	Unit Price	Price
TM30-VSI	30 Gal. Vertical Slip-in CAFS: Modular thin-line fram, plumbed 30 gal. solution tank, 92) 80 cu ft SCUBA cylinders w/valves, custom air bottle mount, gauges, adj. regulator, gauge/regulator panel, '6 supply hose w/hardware, funnel/adapter, purge kit (Does not include hose or Hose Reel)	2	\$ 8,859.25	\$ 17,718.50
F24-23-24	Hannay Hose Reel 1' x 100' w/FH3 Roller & Guide	2	\$ 1,024.59	\$ 2,049.18
1x50FLH	1" x 50' Double Jacket Flat Lay Hose	4	\$ 345.10	\$ 1,380.40
VB1560	Viper Pistol Grip Nozzle 1"	2	\$ 270.15	\$ 540.30
FOB Anchorage, Alaska 99501				
Subtotal				\$ 21,688.38
Shipping				\$ 835.23
Total				\$ 22,523.61

Prices are based on weights provided by customer at quote time.

All deliveries are dependent upon safe berthing, water levels, and ice conditions,

By signing I agree to the above rates for the items described and reserve the barge space needed on the next available sailing:

By: _____
 For: _____
 Title: _____

ARCTIC FIRE & SAFETY
702 30TH AVE
FAIRBANKS, AK 99701
P: 907-452-7806
F: 907-452-7876



INVOICE **ASSIGN**
ID #: 55952
CUSTOMER
POS STATION 12
PAGE NUMBER Page 1 of 1

BILL TO:
CITY OF PILOTPPOINT

Estimate

SHIP TO:

ORDER DATE	1/23/2014	CUSTOMER PO	CLERK NAME	Dave Lumley
SHIP DATE	1/23/2014	TERMS		

Our Part #	MFG Part #	Description	Ordered	Shipped	Price	Total	Tax
164070	013193	CARTRIDGE/LT-10-R DOT 1EA	1	21	59.00	59.00	
164058	005373	CARTRIDGE/N2LT-30-R DOT 1EA	12	12	107.00	1,284.00	
						108.00	

59
59

108

	1392.00
Sub Total	\$1,343.00
Total	\$1,343.00

NET 30 DAYS. 18% APR WILL BE CHARGED ON PAST DUE AMOUNTS. I AGREE TO PAY THE ABOVE TOTAL AMOUNT ACCORDING TO TERMS. MY SIGNATURE ACKNOWLEDGES ACCEPTANCE OF THIS SALE.

SIGNATURE: _____
PRINTED NAME _____

Ansul fire
ext - 13

Customer Name

- Compose
- Inbox
- Drafts (14)
- Sent
- Spam (1)
- Trash
- Folders (8)
- Recent
- Messenger
- Calendar
- Contacts
- Notepad
- Yahoo Mail for Mobile
- Send Feedback

⏪ ⏩ 🗑 Delete 📁 Move ▾ 🛡 Spam ▾ 📎 More ▾ ☰ Collapse All ✕

Estimate_CITY_OF_PILOT_POINT

Dave Lumley 🕒 Today at 3:36 PM
To Me

Matt,
Attached is your quote for the cartridges. These will need to be shipped as haz-mat due to the compressed cartridges. Let me know if we want to proceed. Feel free to contact me with any questions or concerns....Dave

C:\DOCUME~1\Owner\LOCALS~1\Temp\Estimate_CITY_OF_PILOT_POINT.pdf

▾ 1 Attachment

Estimate_CITY_OF..._pdf Download ▾

Reply, Reply All or Forward | More

Dive Alaska!

9191 Old Seward Hwy., Unit 18, Anchorage, AK 99515
Phone: (907) 770-1778, Fax: (907) 770-5033
Email: , Web: www.divealaska.net



Michael Veal

A/R Balance:

Print Date: 1/22/2014 12:03:31 PM
Employee: Nick Lavoie

Quote

Qty	Stock No.	Stock Item	Unit Price	Price
1	MA35E1-110	Max Air 35 Single Phase, 110V	\$4,150.00	\$4,150.00
1	shipping	Shipping Charge to Dive Alaska	\$492.00	\$492.00

Sub-Total: \$4642.00
0
Grand Total: \$4642.00

This Quote is valid until: 4/22/2014

to fill tanks on
tri max &
Scba equip

Eagle Enterprises, Inc.

1041 Ocean Dr., Homer, AK. 99603.

907-235-7907- phone, 907-235-7937- fax.

QUOTE

DATE: 1/22/14

NUMBER OF PAGES: 1

To: Michael Veal / City of Pilot Point

RE: Fire Extinguishers

Phone: 907-797-2200

Email: mdv.copp@yahoo.com

Prices based on purchase of all items below.

From: Lisa Wise

EAGLE ENTERPRISES, INC.

1041 Ocean Dr.

Homer, AK 99603

Phone: **907-235-7907**

Fax: **907-235-7937**

Email: **lisaw@eaglesafety.net**

REMARKS: Urgent For your review Reply ASAP Please comment

<i>Quantity:</i>	<i>Item #:</i>	<i>Description:</i>	<i>Price:</i>	<i>Extension:</i>
40 ea	B456	Amerex 10lb. ABC Fire Extinguisher w/wall hook	\$75.00	\$3000.00
25 ea	B500	Amerex 5lb. ABC Fire Extinguisher w/wall hook	\$55.00	\$1375.00

GRAND TOTAL: \$4375.00

Prices expire 1/31/14.

Prices are FOB Eagle Enterprises Anchorage.

Estimated lead time - 14 days from date ordered.



ALASKA INDUSTRIAL HARDWARE, INC.

QUOTE NUMBER
CQ14330-WC

- #1. 2192 VIKING DRIVE ANCHORAGE, ALASKA 99501 276-7201
- #2. 2716 COMMERCIAL DR. ANCHORAGE, ALASKA 99501 272-1441
- #3. 751 W. COMMERCIAL DR. WASILLA, ALASKA 99654 376-5274
- #4. 5655 OLD SEWARD HWY. ANCHORAGE, ALASKA 99503 561-1781
- #5. 2951 AIRPORT WAY FAIRBANKS, ALASKA 99709 452-4788
- #6. 193 BRIDGE ACCESS RD. KENAI, ALASKA 99611 283-3531
- #7. 12340 OLD GLENN HWY. EAGLE RIVER, ALASKA 99577 694-2988
- #8. 9141 GLACIER HWY. JUNEAU, ALASKA 99801 790-3300

ACCOUNT
19382

PAGE 1 OF 1

*** C. O. D. ***

www.aih.com
aihsales@aih.com

TO:

PILOT POINT CITY OF
2200 MAIN STREET

PILOT POINT AK 99649

ATTN:

10:27AM COD CONTACT PHONE: 797-2200

SHIP TO:

PILOT POINT CITY OF
2200 MAIN STREET
MICHAEL VEAL 797-2200
PILOT POINT AK 99649

ATTN:

DATE	LOC	SLM#	SHIPPED VIA	FOB	CUSTOMER ORDER #	TERMS
01-21-14	1	112	WILL CALL	ANCHORAGE		CASH

MFG. PREFIX	CATALOG NUMBER	QTY ORDERED	QTY SHIPPED	UNIT	DESCRIPTION	UNIT PRICE	AMOUNT
KID	05785	40		EA	PRO FIRE EXTINGUISHER 4A,60BC RATES (10#)	88.490	3539.60
KID	06204	28		EA	FIRE AWAY EXTINGUISHER 3A,40BC RATED (5#)	41.700	1167.60
SUBTOTAL:							4,707.20

THANKS
DOUG

EXTINGUISHERS HAVE TO BE SHIPPED IN FULL CASES
10#-(2/CASE) 5#-(4/CASE)

Total Quote Weight: 986 Lbs

Quote Total: 4707.20

Quote created by Douglas W Ford (dford@aihalaska.com)

Quote expires on 04-21-14

When paying for a quote please reference the quote number on your check.

Quote

CUSTOMER SIGNATURE _____

DATE _____

Alaska Village Initiatives
 1577 C Street, Suite 304
 Anchorage, AK 99501
 1-800-478-2332

January 22, 2014

FREIGHT RATE QUOTE

Shipper	George Quinto	Consignee	Michael Veal	Payor	Michael Veal
Company	Alaska Village Initiatives	Company	City of Pilot Point	Company	City of Pilot Point
Address	1577 C Street, Ste. 304 Anchorage, AK 99501	Address		Address	
Phone	907-263-9826	Phone	797-2200	Phone	797-2200
Fax	907-263-9971	Fax		Fax	
e-mail		e-mail		e-mail	

Item Code	Description	QTY	Unit Price	Price
TMSUPER20 0-LP	200 Gal. Low Profile Skid Supercafs (1"&1 1/2" Discharge): Plumbed 200 Gas. Solution tank, (2) 300 cu ft ind. Cylinders, valves and mounts, air recharge port, gauges, (2) high flow adjustable regulators, gauge /regular panel, manuel HR #F4038-17-18, 100'x1 3/4" double jacket flat lay hose, 1" & 1 1/2" vipor pistol grip nozzles, copolymer horizontal SKID, 45000 adaptor, funnel/adapter, purge kit	1	\$ 30,272.60	\$ 30,272.60
Blizzard D 45000	Chemguard Freeze Protected Foam (55 gallon Drum) CGA 346 Industrial female to SCUBA Block Adapter	6 1	\$ 1,878.63 \$ 139.85	\$ 11,271.78 \$ 139.85
90GHE HD St	10.8 scfm, 9hp Electir start Honda gasoline engine w/6'air intake tubing, with automatic pressure shut off, tach hour meter, manual drains, (2) 4; fill hoses w/ on/off bleed valve, ES-90GE Electric start, BP-12V-GE battery pack for electric start on Honda engine, CD-1000+ automatic condensate drain, Ht1006+ High temperature shut down switch, LO-1005+ Low oil shut down switch, LF-306714 (2) dryer disposable cartdridge	1	\$ 11,900.00	\$ 11,900.00
FOB Anchorage, Alaska				
Subtotal				\$ 53,584.23
Shipping				\$ 1,673.25
Total				\$ 55,257.48

Prices are based on weights provided by customer at quote time.
 All deliveries are dependent upon safe berthing, water levels, and ice conditions,

By signing I agree to the above rates for the items described and reserve the barge space needed on the next available sailing:

By: _____
 For: _____
 Title: _____