

# **State of Alaska FY2022 Governor's Operating Budget**

## **Department of Administration Public Defender Agency Component Budget Summary**

Component: Public Defender Agency

### Contribution to Department's Mission

To provide constitutionally mandated legal representation to indigent clients appointed by the court.

### Results

(Additional performance information is available on the web at <https://omb.alaska.gov/results>.)

### Core Services

- Establish timely and effective communications with clients regarding legal rights, legal process, charges and evidence
- Timely review of case materials to advise clients.
- Timely actions taken on behalf of clients.

### Measures by Core Service

(Additional performance information is available on the web at <https://omb.alaska.gov/results>.)

#### 1. Establish timely and effective communications with clients regarding legal rights, legal process, charges and evidence

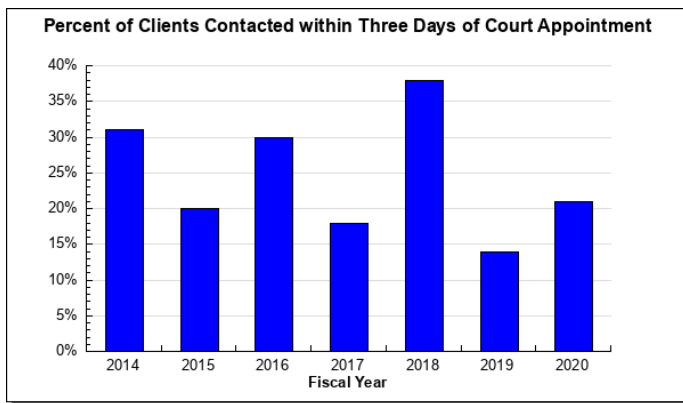

#### 2. Timely review of case materials to advise clients.

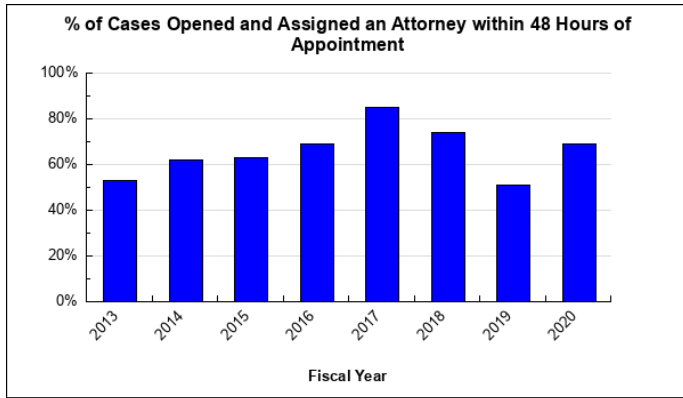

3. Timely actions taken on behalf of clients.

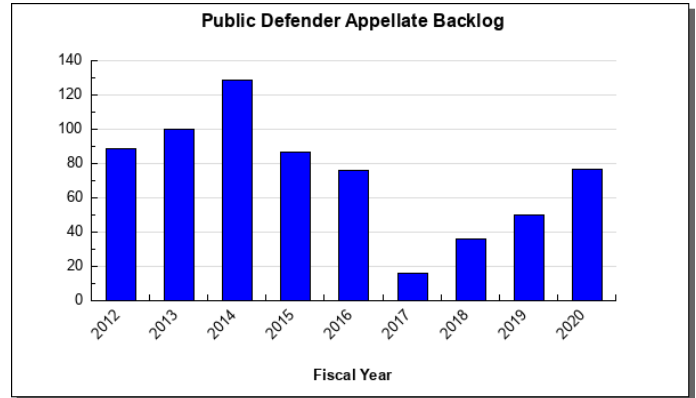
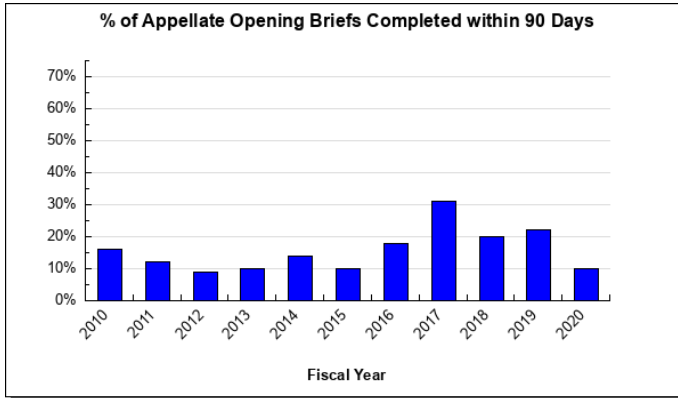

Major Component Accomplishments in 2020

- Established multiple remote support positions to ensure effective delivery of services in areas with difficulty recruiting or with limited bandwidth to complete tasks in support of attorneys.
- Successfully leveraged laptop computers and digital solutions to help manage Agency’s Covid-19 response.
- Successfully reduced Agency vacancy rate for attorney positions with aggressive recruitment efforts.
- Completed training for supervisors to increase their knowledge and proficiency in the application of Agency and State of Alaska policies and procedures.

Key Component Challenges

**Increasing Workloads** - The Public Defender Agency (PDA) continues to experience increases in workload per attorney and has been impacted most significantly in the past fiscal year by a growing backlog of cases created by retention challenges in prior fiscal years and pre-trial delay from COVID-19 mitigation efforts, like the suspension of jury trials and speedy trial rights. The increase in workload, despite full staffing, for remaining attorneys and support staff presents substantial challenges for document processing, client communication, and case review and preparation.

Significant Changes in Results to be Delivered in FY2022

**Digital Solutions** - PDA will continue to work with the Department of Corrections on mechanisms to enable video meetings with clients.

**Holistic Defense** - PDA continues to expand the holistic defense model to provide more direct support for attorneys by assisting clients directly with communication and access to services and community resources.

**Efficiency Initiatives** - PDA will continue to explore efficiency initiatives and expand or continue the use of those initiated in prior fiscal years such as, support staff time studies and workload reorganization, web-based training opportunities, and centralization of support functions.

Statutory and Regulatory Authority

- |  |   |
|--|---|
| U.S. Constitution, Amendment VI                        | The Federal Right to Counsel                |
| Alaska Constitution, Article 1, Sec.11                 | The State Right to Counsel                  |
| AS 18.85.010 et seq.                                   | The Public Defender Agency Enabling Statute |
| Alaska Criminal Rule 39 and 39.1                       |   |
| Appellate Rule 209                                     |   |
| Financial Eligibility Guidelines for Appointed Counsel |   |

**Contact Information**

**Contact:** Samantha Cherot, Public Defender  
**Phone:** (907) 334-4414  
**E-mail:** samantha.cherot@alaska.gov

Public Defender Agency Personal Services Information				
Authorized Positions			Personal Services Costs	
	FY2021 Management Plan	FY2022 Governor		
Full-time	184	184	Annual Salaries	16,295,803
Part-time	1	1	COLA	43,045
Nonpermanent	9	9	Premium Pay	0
			Annual Benefits	9,021,984
			<i>Less 4.40% Vacancy Factor</i>	(1,115,832)
			Lump Sum Premium Pay	0
<b>Totals</b>	<b>194</b>	<b>194</b>	<b>Total Personal Services</b>	<b>24,245,000</b>

Position Classification Summary					
Job Class Title	Anchorage	Fairbanks	Juneau	Others	Total
Accounting Technician II	1	0	0	0	1
Administrative Assistant I	1	0	0	0	1
Administrative Assistant III	1	0	0	0	1
Administrative Officer I	1	0	0	0	1
Associate Attorney I	3	1	0	1	5
Associate Attorney II	1	0	0	0	1
Attorney I	5	2	0	5	12
Attorney II	5	0	1	5	11
Attorney III	8	5	2	9	24
Attorney IV	24	5	2	10	41
Attorney V	9	2	1	6	18
Attorney VI	4	0	0	0	4
Investigator I	0	0	0	1	1
Investigator II	1	0	0	0	1
Investigator III	3	2	1	6	12
Law Office Assistant I	14	3	1	9	27
Law Office Assistant II	3	1	0	5	9
Office Assistant II	1	0	0	0	1
Paralegal I	6	1	0	5	12
Paralegal II	6	1	1	2	10
Public Defender	1	0	0	0	1
<b>Totals</b>	<b>98</b>	<b>23</b>	<b>9</b>	<b>64</b>	<b>194</b>

**Component Detail All Funds**  
**Department of Administration**

**Component:** Public Defender Agency (1631)  
**RDU:** Legal and Advocacy Services (11)

Non-Formula Component

	FY2020 Actuals	FY2021 Conference Committee	FY2021 Authorized	FY2021 Management Plan	FY2022 Governor	FY2021 Management Plan vs FY2022 Governor	
71000 Personal Services	21,605.6	24,054.0	24,054.0	24,228.9	24,245.0	16.1	0.1%
72000 Travel	425.3	514.6	514.6	529.6	529.6	0.0	0.0%
73000 Services	5,987.1	3,932.9	3,932.9	3,936.8	3,936.8	0.0	0.0%
74000 Commodities	392.3	235.1	235.1	235.1	235.1	0.0	0.0%
75000 Capital Outlay	0.0	0.0	0.0	0.0	0.0	0.0	0.0%
77000 Grants, Benefits	0.0	0.0	0.0	0.0	0.0	0.0	0.0%
78000 Miscellaneous	0.0	193.8	193.8	0.0	0.0	0.0	0.0%
<b>Totals</b>	<b>28,410.3</b>	<b>28,930.4</b>	<b>28,930.4</b>	<b>28,930.4</b>	<b>28,946.5</b>	<b>16.1</b>	<b>0.1%</b>
<b>Fund Sources:</b>							
1001 CBR Fund (UGF)	0.0	6,772.5	6,772.5	6,772.5	0.0	-6,772.5	-100.0%
1004 Gen Fund (UGF)	25,616.6	20,317.6	20,317.6	20,317.6	27,133.4	6,815.8	33.5%
1005 GF/Prgm (DGF)	510.1	578.4	578.4	578.4	578.4	0.0	0.0%
1007 I/A Rcpts (Other)	650.2	508.1	508.1	508.1	508.1	0.0	0.0%
1037 GF/MH (UGF)	181.3	554.0	554.0	554.0	554.6	0.6	0.1%
1092 MHTAAR (Other)	152.8	199.8	199.8	199.8	86.0	-113.8	-57.0%
1169 PCE Endow (DGF)	1,299.3	0.0	0.0	0.0	0.0	0.0	0.0%
1268 MH Tr Res (DGF)	0.0	0.0	0.0	0.0	86.0	86.0	100.0%
<b>Unrestricted General (UGF)</b>	<b>25,797.9</b>	<b>27,644.1</b>	<b>27,644.1</b>	<b>27,644.1</b>	<b>27,688.0</b>	<b>43.9</b>	<b>0.2%</b>
<b>Designated General (DGF)</b>	<b>1,809.4</b>	<b>578.4</b>	<b>578.4</b>	<b>578.4</b>	<b>664.4</b>	<b>86.0</b>	<b>14.9%</b>
<b>Other Funds</b>	<b>803.0</b>	<b>707.9</b>	<b>707.9</b>	<b>707.9</b>	<b>594.1</b>	<b>-113.8</b>	<b>-16.1%</b>
<b>Federal Funds</b>	<b>0.0</b>	<b>0.0</b>	<b>0.0</b>	<b>0.0</b>	<b>0.0</b>	<b>0.0</b>	<b>0.0%</b>
<b>Positions:</b>							
Permanent Full Time	182	182	182	184	184	0	0.0%
Permanent Part Time	1	1	1	1	1	0	0.0%
Non Permanent	10	10	10	9	9	0	0.0%

**Change Record Detail - Multiple Scenarios with Descriptions**  
**Department of Administration**

**Component:** Public Defender Agency (1631)  
**RDU:** Legal and Advocacy Services (11)

Scenario/Change Record Title	Trans Type	Totals	Personal Services	Travel	Services	Commodities	Capital Outlay	Grants, Benefits	Miscellaneous	Positions		NP
										PFT	PPT	
***** Changes From FY2021 Conference Committee To FY2021 Authorized *****												
<b>Conference Committee</b>												
	ConfCom	28,930.4	24,054.0	514.6	3,932.9	235.1	0.0	0.0	193.8	182	1	10
1001 CBR Fund		6,772.5										
1004 Gen Fund		20,317.6										
1005 GF/Prgm		578.4										
1007 I/A Rcpts		508.1										
1037 GF/MH		554.0										
1092 MHTAAR		199.8										
<b>Subtotal</b>		<b>28,930.4</b>	<b>24,054.0</b>	<b>514.6</b>	<b>3,932.9</b>	<b>235.1</b>	<b>0.0</b>	<b>0.0</b>	<b>193.8</b>	<b>182</b>	<b>1</b>	<b>10</b>
***** Changes From FY2021 Authorized To FY2021 Management Plan *****												
<b>Align Authority with Anticipated Expenditures</b>												
	LIT	0.0	174.9	15.0	3.9	0.0	0.0	0.0	-193.8	0	0	0
<p>Authorization for Mental Health Trust Authority budget to match Trustee approved budget was restored in the miscellaneous expenditure line. In order to use the funds as intended, the funds are adjusted to the correct expenditure lines.</p>												
<b>Delete Vacant Non-Permanent Law Office Assistant I (02-N07034)</b>												
	PosAdj	0.0	0.0	0.0	0.0	0.0	0.0	0.0	0.0	0	0	-1
<p>Delete a vacant on-call non-permanent Law Office Assistant I (02-N07034), range 11, located in Juneau, as it is no longer needed due to the addition of a full-time Law Office Assistant I position.</p>												
<b>Add Associate Attorney I and Paralegal I/II for Holistic Defense Expansion</b>												
	PosAdj	0.0	0.0	0.0	0.0	0.0	0.0	0.0	0.0	2	0	0
<p>The Public Defender Agency and the Alaska Legal Services Corporation will continue to administer the Holistic Defense model in Bethel and is expanding the project to Nome and other locations. The target population will be Trust beneficiaries not participating in the Bethel Therapeutic court and will be clients assigned to the public defender.</p> <p>Project participants' legal needs will be addressed by a criminal attorney. Non-attorney staff and volunteers will assist with participants' unmet social support needs, and where possible, a civil legal aid attorney will work with the team to address project participants' civil legal needs. All program services are designed to address participant obstacles to successful reintegration and self-sufficiency, improving case outcomes, and reducing incarceration and related costs.</p>												
<b>Subtotal</b>		<b>28,930.4</b>	<b>24,228.9</b>	<b>529.6</b>	<b>3,936.8</b>	<b>235.1</b>	<b>0.0</b>	<b>0.0</b>	<b>0.0</b>	<b>184</b>	<b>1</b>	<b>9</b>
***** Changes From FY2021 Management Plan To FY2022 Governor *****												
<b>Reverse MH: Holistic Defense in Bethel</b>												
	OTI	-199.8	-180.9	-15.0	-3.9	0.0	0.0	0.0	0.0	0	0	0

**Change Record Detail - Multiple Scenarios with Descriptions**  
**Department of Administration**

**Component:** Public Defender Agency (1631)  
**RDU:** Legal and Advocacy Services (11)

Scenario/Change Record Title	Trans Type	Totals	Personal Services	Travel	Services	Commodities	Capital Outlay	Grants, Benefits	Miscellaneous	Positions		
										PFT	PPT	NP
1092 MHTAAR		-199.8										

The Public Defender Agency is working to obtain better outcomes for clients, reduce further contacts with the justice system, and reduce future costs to the State by deploying paraprofessionals to the holistic defense initiative (HDI).

The HDI aids connecting clients to services based upon the individualized needs of the client. Addressing the underlying concerns that bring clients into contact with the justice system reduces future contacts with the justice system, reduces the need to access expensive emergency services and reduces time to disposition in child custody cases, promoting better outcomes for children and families (an efficacy analysis is expected in 2021). The Holistic Defense Initiative is an innovative and low-cost mechanism for offering proactive contributions to the State of Alaska and implementing innovations to advance the agency's mission.

**FY2022 Salary Adjustments**

	SalAdj	43.9	43.9	0.0	0.0	0.0	0.0	0.0	0.0	0.0	0	0	0
1004 Gen Fund		43.3											
1037 GF/MH		0.6											

FY2022 1% COLA for ASEA/General Government (GG/GP/GY/GZ): \$43.9

**MH Trust: Holistic Defense - Bethel**

	IncT	86.0	67.1	15.0	3.9	0.0	0.0	0.0	0.0	0.0	0	0	0
1268 MH Tr Res		86.0											

The Public Defender Agency and the Alaska Legal Services Corporation will continue to administer the Holistic Defense model in Bethel, Nome, and Kotzebue and will expand the project to Anchorage in FY2022. The target population will be Trust beneficiaries not participating in the Bethel or Anchorage Therapeutic Courts or other diversion projects and will be randomly selected from clients assigned to the public defender in the Bethel, Nome, Kotzebue and Anchorage regions.

Project participants' legal needs will be addressed by a criminal attorney. A social worker will continue to assist with participants' unmet social support needs and a civil legal aid attorney will work with the team to address project participants' civil legal needs. All program services are designed to address participant obstacles to successful reintegration and self-sufficiency; thus, participant recidivism will be reduced resulting in increased public protection and keeping Alaskans safe.

Use of budget fund code 1268 directs expenditure of money held in reserve in the Mental Health Trust Settlement Income Account in excess of the amount directed for use by the Trust through annual recommendations (state accounting system fund 3321). Per AS 37.14.041(b) money in excess of the amount needed to meet the necessary expenses of the state's integrated comprehensive mental health program shall be transferred to the general fund and used for any public purpose. To ensure these monies are expended to the benefit of the state's mental health program and not swept to the general fund, a portion of the reserves are being utilized to fund various mental health programs and Trust recommendations with the intent of drawing reserves down over a period of five years.

**MH Trust: Holistic Defense - Bethel**

	IncT	86.0	86.0	0.0	0.0	0.0	0.0	0.0	0.0	0.0	0	0	0
1092 MHTAAR		86.0											

The Public Defender Agency and the Alaska Legal Services Corporation will continue to administer the Holistic Defense model in Bethel, Nome, and Kotzebue



**Change Record Detail - Multiple Scenarios with Descriptions**  
**Department of Administration**

**Component:** Public Defender Agency (1631)  
**RDU:** Legal and Advocacy Services (11)

Scenario/Change Record Title	Trans Type	Totals	Personal Services	Travel	Services	Commodities	Capital Outlay	Grants, Benefits	Miscellaneous	Positions		
										PFT	PPT	NP
<p>and will expand the project to Anchorage in FY2022. The target population will be Trust beneficiaries not participating in the Bethel or Anchorage Therapeutic Courts or other diversion projects and will be randomly selected from clients assigned to the public defender in the Bethel, Nome, Kotzebue and Anchorage regions.</p> <p>Project participants' legal needs will be addressed by a criminal attorney. A social worker will continue to assist with participants' unmet social support needs and a civil legal aid attorney will work with the team to address project participants' civil legal needs. All program services are designed to address participant obstacles to successful reintegration and self-sufficiency; thus, participant recidivism will be reduced resulting in increased public protection and keeping Alaskans safe.</p>												
<b>Fund Source Adjustment of CBRF to UGF</b>												
	FndChg	0.0	0.0	0.0	0.0	0.0	0.0	0.0	0.0	0	0	0
1001 CBR Fund		-6,772.5										
1004 Gen Fund		6,772.5										
Replace Constitutional Budget Reserve Fund (CBRF) used as a one-time funding mechanism in FY2021.												
<b>Totals</b>		<b>28,946.5</b>	<b>24,245.0</b>	<b>529.6</b>	<b>3,936.8</b>	<b>235.1</b>	<b>0.0</b>	<b>0.0</b>	<b>0.0</b>	<b>184</b>	<b>1</b>	<b>9</b>

**Line Item Detail (1676)**  
**Department of Administration**  
**Travel**

**Component:** Public Defender Agency (1631)

Line Number	Line Name		FY2020 Actuals	FY2021 Management Plan	FY2022 Governor
2000	Travel		425.3	529.6	529.6
Object Class	Servicing Agency	Explanation	FY2020 Actuals	FY2021 Management Plan	FY2022 Governor
<b>2000 Travel Detail Totals</b>			<b>425.3</b>	<b>529.6</b>	<b>529.6</b>
2000	In-State Employee Travel	Transportation costs for travel relating to administration, training, conventions and meetings, boards and commissions	319.9	374.3	375.1
2001	In-State Non-Employee Travel	Transportation costs for travel relating to meetings and boards for non-employees	41.4	64.6	54.6
2002	Out of State Employee Travel	Transportation costs for staff travel out of state to national organization meetings, conferences, and training	5.3	11.3	16.8
2003	Out of State Non-Employee Travel	Out of state airfare, surface transportation, lodging and meals and incidentals for expert witnesses and witnesses needed for evaluation, testimony, etc. The PDA has a waiver for all out of state travel expenditures for experts and witnesses.	14.6	54.8	39.0
2005	Moving Costs	Moving and relocation costs	44.1	24.6	44.1

**Line Item Detail (1676)**  
**Department of Administration**  
**Services**

**Component:** Public Defender Agency (1631)

<b>Line Number</b>	<b>Line Name</b>		<b>FY2020 Actuals</b>	<b>FY2021 Management Plan</b>	<b>FY2022 Governor</b>
3000	Services		5,987.1	3,936.8	3,936.8
<b>Object Class</b>	<b>Servicing Agency</b>	<b>Explanation</b>	<b>FY2020 Actuals</b>	<b>FY2021 Management Plan</b>	<b>FY2022 Governor</b>
<b>3000 Services Detail Totals</b>			<b>5,987.1</b>	<b>3,936.8</b>	<b>3,936.8</b>
3000	Education Services	Training, educational conferences, agency memberships, and employee tuition	61.3	54.1	7.9
3002	Legal and Judicial Services	Contract attorney expenditures related to appellate cases, expert witness fees, transcription services and miscellaneous case costs (medical record requests, etc.).	2,674.3	1,021.6	1,562.6
3003	Information Technology	Software licensing and maintenance, training, and consulting	127.8	130.4	129.3
3004	Telecommunications	Local, long distance, and cellular telephone charges, television, data/network, telecommunication equipment, and other wireless charges from outside vendors	94.3	90.0	93.8
3005	Health Services	Expert witness expenditures related to psychiatric testing and medical lab testing.	20.5	17.0	17.0
3006	Delivery Services	Freight, courier services, and postage	119.2	48.5	60.4
3007	Advertising and Promotions	Advertising, promotions and legal notices	0.3	0.3	0.3
3008	Utilities	Electricity, heating fuel, water, sewage and disposal services	19.0	18.2	19.0
3009	Structure/Infrastructure/Land	Structure, infrastructure and land repairs, maintenance, rental, and leases	273.8	208.0	221.0

**Line Item Detail (1676)**  
**Department of Administration**  
**Services**

**Component:** Public Defender Agency (1631)

Object Class	Servicing Agency	Explanation	FY2020 Actuals	FY2021 Management Plan	FY2022 Governor
<b>3000 Services Detail Totals</b>			<b>5,987.1</b>	<b>3,936.8</b>	<b>3,936.8</b>
3010	Equipment/Machinery	Machinery, furniture and office equipment purchase, repairs, maintenance, rentals, and leases	2.1	2.5	2.1
3011	Other Services	Interpreter services, print and copy services for case related exhibits and Bethel Jesuit Volunteer placement fee	81.3	40.0	38.0
3017	Inter-Agency Information Technology Non-Telecommunications	Admin - Alaska Division of IT (3141) Server hosting fees	630.5	73.8	73.8
3017	Inter-Agency Information Technology Non-Telecommunications	Admin - Alaska Division of IT (3141) OIT Core Services Chargeback	0.0	556.7	328.0
3018	Inter-Agency Information Technology Telecommunications	Admin - Alaska Division of IT (3141) OIT Telecommunications (CISCO device config, deployment, maintenance, replacements, and other telephone line services)	64.3	63.0	64.3
3021	Inter-Agency Mail	Admin - Print Services (2333) Centralized mail services chargeback	4.1	4.1	4.1
3022	Inter-Agency Human Resources	Admin - Personnel (56) DOA - HR chargeback	116.4	116.4	116.4
3023	Inter-Agency Building Leases	Admin - Facilities (2429) Rent for state-owned facilities and lease payments	171.2	198.4	185.9
3023	Inter-Agency Building Leases	Admin - Facilities Administration (2430) Rent for state-owned facilities and lease payments	14.7	0.0	0.0
3023	Inter-Agency Building Leases	Admin - Leases (81) Rent for state-owned facilities and lease payments	575.8	584.8	439.1
3024	Inter-Agency Legal	Legal services provided by the Department of Law	287.3	0.0	0.0
3024	Inter-Agency Legal	Correct - Department-wide Legal services provided by the Department of Law	0.1	0.0	0.0
3024	Inter-Agency Legal	Courts - Department-wide Transcript (ACS RSA) expenditures	0.0	246.0	125.0
3024	Inter-Agency Legal	Law - Department-wide Discovery (LAW RSA) expenditures	0.0	45.0	40.0
3026	Inter-Agency Insurance	Admin - Risk Management (71) Risk Management chargeback	6.5	6.5	6.5

**Line Item Detail (1676)**  
**Department of Administration**  
**Services**

**Component:** Public Defender Agency (1631)

Object Class		Servicing Agency	Explanation	FY2020 Actuals	FY2021 Management Plan	FY2022 Governor
<b>3000 Services Detail Totals</b>				<b>5,987.1</b>	<b>3,936.8</b>	<b>3,936.8</b>
3027	Inter-Agency Financial	Admin - Finance (59)	Division of Finance Chargeback for IRIS FIN, HRM, and ALDER	10.9	10.9	10.9
3028	Inter-Agency Americans with Disabilities Act Compliance	Admin - Personnel (56)	Americans with Disabilities Act (ADA) Chargeback	1.4	1.4	1.4
3030	Inter-Agency Hearing/Mediation	Admin - Administrative Hearings (2771)	Hearing Officer services	240.0	0.0	0.0
3038	Inter-Agency Management/Consulting	Admin - Accounting (3134)	SSoA Accounts Payable and Travel chargeback	65.8	75.0	65.8
3038	Inter-Agency Management/Consulting	Admin - Administrative Services (46)	Administrative chargeback	173.9	173.9	173.9
3038	Inter-Agency Management/Consulting	Admin - Office of the Commissioner (45)	Commissioner's Office chargeback	137.0	137.0	137.0
3038	Inter-Agency Management/Consulting	Admin - Stwd Contracting and Property (3262)	SSoA Procurement chargeback	13.3	13.3	13.3

**Line Item Detail (1676)**  
**Department of Administration**  
**Commodities**

**Component:** Public Defender Agency (1631)

Line Number	Line Name		FY2020 Actuals	FY2021 Management Plan	FY2022 Governor
4000	Commodities		392.3	235.1	235.1
Object Class	Servicing Agency	Explanation	FY2020 Actuals	FY2021 Management Plan	FY2022 Governor
<b>4000 Commodities Detail Totals</b>			<b>392.3</b>	<b>235.1</b>	<b>235.1</b>
4000	Business	General business supplies such as office consumables, furniture, and computer equipment	384.9	231.9	234.2
4002	Household/Institutional	Cleaning, food and other household supplies	3.8	3.2	0.9
4004	Safety	Safety supplies, including fire suppression, personal protection gear	2.1	0.0	0.0
4005	Building Materials	Building materials and supplies	1.0	0.0	0.0
4015	Parts and Supplies	Parts, supplies, maintenance and repair items	0.5	0.0	0.0

**Line Item Detail (1676)**  
**Department of Administration**  
**Grants, Benefits**

**Component:** Public Defender Agency (1631)

<b>Line Number</b>	<b>Line Name</b>		<b>FY2020 Actuals</b>	<b>FY2021 Management Plan</b>	<b>FY2022 Governor</b>
7000	Grants, Benefits		0.0	0.0	0.0
<b>Object Class</b>	<b>Servicing Agency</b>	<b>Explanation</b>	<b>FY2020 Actuals</b>	<b>FY2021 Management Plan</b>	<b>FY2022 Governor</b>
<b>7000 Grants, Benefits Detail Totals</b>			<b>0.0</b>	<b>0.0</b>	<b>0.0</b>
7001	Grants	AmeriCorps grant program	0.0	0.0	0.0

**Revenue Detail (1681)**  
**Department of Administration**

**Component:** Public Defender Agency (1631)

Revenue Type (OMB Fund Code) Revenue Source	Component	Comment	FY2020 Actuals	FY2021 Management Plan	FY2022 Governor
<b>5005 GF/Prgm (1005 GF/Prgm)</b>			<b>522.0</b>	<b>578.4</b>	<b>578.4</b>
5102 Program Receipts Public Protection - Fines and Forfeitures		Rule 39 funds collected from Alaska Permanent Fund garnishments	522.0	578.4	578.4
<b>5007 I/A Rcpts (1007 I/A Rcpts)</b>			<b>650.2</b>	<b>508.1</b>	<b>508.1</b>
5301 Inter-Agency Receipts	Commerce - Department-wide	AmeriCorps RSA	155.2	0.0	0.0
5301 Inter-Agency Receipts	Courts - Department-wide	ACS Therapeutic Court reimbursable services agreement	495.0	508.1	508.1
<b>6004 Gen Fund (1004 Gen Fund)</b>			<b>2.4</b>	<b>0.0</b>	<b>0.0</b>
6046 General Fund - Prior Year Reimbursement Recovery		Prior year recovery	2.4	0.0	0.0



**Inter-Agency Services (1682)**  
**Department of Administration**

**Component:** Public Defender Agency (1631)

				FY2020 Actuals	FY2021 Management Plan	FY2022 Governor
<b>Component Totals</b>				<b>2,225.9</b>	<b>2,306.2</b>	<b>1,785.4</b>
With Department of Administration				2,225.8	2,015.2	1,620.4
With Department of Corrections				0.1	0.0	0.0
With Judiciary				0.0	246.0	125.0
With Department of Law				0.0	45.0	40.0
<b>Object Class</b>	<b>Servicing Agency</b>	<b>Explanation</b>		FY2020 Actuals	FY2021 Management Plan	FY2022 Governor
3017	Inter-Agency Information Technology Non-Telecommunications	Admin - Alaska Division of IT (3141)	Server hosting fees	630.5	73.8	73.8
3017	Inter-Agency Information Technology Non-Telecommunications	Admin - Alaska Division of IT (3141)	OIT Core Services Chargeback	0.0	556.7	328.0
3018	Inter-Agency Information Technology Telecommunications	Admin - Alaska Division of IT (3141)	OIT Telecommunications (CISCO device config, deployment, maintenance, replacements, and other telephone line services)	64.3	63.0	64.3
3021	Inter-Agency Mail	Admin - Print Services (2333)	Centralized mail services chargeback	4.1	4.1	4.1
3022	Inter-Agency Human Resources	Admin - Personnel (56)	DOA - HR chargeback	116.4	116.4	116.4
3023	Inter-Agency Building Leases	Admin - Facilities (2429)	Rent for state-owned facilities and lease payments	171.2	198.4	185.9
3023	Inter-Agency Building Leases	Admin - Facilities Administration (2430)	Rent for state-owned facilities and lease payments	14.7	0.0	0.0
3023	Inter-Agency Building Leases	Admin - Leases (81)	Rent for state-owned facilities and lease payments	575.8	584.8	439.1
3024	Inter-Agency Legal	Correct - Department-wide	Legal services provided by the Department of Law	0.1	0.0	0.0
3024	Inter-Agency Legal	Courts - Department-wide	Transcript (ACS RSA) expenditures	0.0	246.0	125.0
3024	Inter-Agency Legal	Law - Department-wide	Discovery (LAW RSA) expenditures	0.0	45.0	40.0
3026	Inter-Agency Insurance	Admin - Risk Management (71)	Risk Management chargeback	6.5	6.5	6.5
3027	Inter-Agency Financial	Admin - Finance (59)	Division of Finance Chargeback for IRIS FIN, HRM, and ALDER	10.9	10.9	10.9

**Inter-Agency Services (1682)**  
**Department of Administration**

**Component:** Public Defender Agency (1631)

<b>Object Class</b>	<b>Servicing Agency</b>	<b>Explanation</b>	<b>FY2020 Actuals</b>	<b>FY2021 Management Plan</b>	<b>FY2022 Governor</b>
3028 Inter-Agency Americans with Disabilities Act Compliance	Admin - Personnel (56)	Americans with Disabilities Act (ADA) Chargeback	1.4	1.4	1.4
3030 Inter-Agency Hearing/Mediation	Admin - Administrative Hearings (2771)	Hearing Officer services	240.0	0.0	0.0
3038 Inter-Agency Management/Consulting	Admin - Accounting (3134)	SSoA Accounts Payable and Travel chargeback	65.8	75.0	65.8
3038 Inter-Agency Management/Consulting	Admin - Administrative Services (46)	Administrative chargeback	173.9	173.9	173.9
3038 Inter-Agency Management/Consulting	Admin - Office of the Commissioner (45)	Commissioner's Office chargeback	137.0	137.0	137.0
3038 Inter-Agency Management/Consulting	Admin - Stwd Contracting and Property (3262)	SSoA Procurement chargeback	13.3	13.3	13.3

**Personal Services Expenditure Detail**  
**Department of Administration**

**Scenario:** FY2022 Governor (17280)  
**Component:** Public Defender Agency (1631)  
**RDU:** Legal and Advocacy Services (11)

PCN	Job Class Title	Time Status	Retire Code	Barg Unit	Location	Salary Sched	Range / Step	Comp Months	Split / Count	Annual Salaries	COLA	Premium Pay	Annual Benefits	Total Costs	UGF Amount
02-1101	Law Office Assistant II	FT	A	GP	Dillingham	237	13G / J	12.0		73,498	988	0	44,074	118,560	118,560
02-1102	Law Office Assistant I	FT	A	GP	Palmer	200	11C / D	12.0		39,713	534	0	32,452	72,699	72,699
02-1103	Investigator III	FT	A	GP	Juneau	205	18F / G	12.0		74,939	1,007	0	44,569	120,515	120,515
02-1104	Law Office Assistant I	FT	A	GP	Anchorage	200	11B / C	12.0		39,380	529	0	32,337	72,246	72,246
02-1106	Attorney III	FT	A	XE	Palmer	N00	22C / D	12.0		85,664	0	0	48,155	133,819	133,819
02-1108	Investigator III	FT	A	GP	Palmer	200	18J	12.0		76,050	1,022	0	44,952	122,024	122,024
02-1109	Attorney IV	FT	A	XE	Anchorage	N00	24D / E	12.0		101,322	0	0	53,541	154,863	154,863
02-1117	Attorney V	FT	A	XE	Nome	99	25M / N	12.0		182,327	0	0	78,984	261,311	261,311
02-1118	Attorney IV	FT	A	XE	Palmer	N00	24F	12.0		106,451	0	0	55,305	161,756	161,756
02-1119	Investigator III	FT	A	GP	Palmer	200	18E / F	12.0		70,276	945	0	42,965	114,186	114,186
02-1120	Paralegal II	FT	A	GP	Fairbanks	203	16G / J	12.0		67,386	906	0	41,971	110,263	110,263
02-1121	Attorney IV	FT	A	XE	Anchorage	N00	24F	12.0		106,451	0	0	55,305	161,756	161,756
02-1122	Attorney IV	FT	A	XE	Anchorage	N00	24E / F	12.0		103,558	0	0	54,310	157,868	157,868
02-1123	Attorney V	FT	A	XE	Palmer	N00	25M	12.0		130,026	0	0	63,415	193,441	193,441
02-1124	Attorney V	FT	A	XE	Bethel	N50	25F	12.0		171,639	0	0	75,962	247,601	247,601
02-1127	Investigator III	FT	A	GP	Dillingham	237	18E / F	12.0		96,415	1,296	0	51,957	149,668	149,668
02-1128	Attorney I	FT	A	XE	Anchorage	N00	18E / F	12.0		70,794	0	0	43,039	113,833	113,833
02-1129	Law Office Assistant I	FT	A	GP	Anchorage	200	11E / F	12.0		42,716	574	0	33,485	76,775	76,775
02-1130	Attorney II	FT	A	XE	Anchorage	N00	20D / E	12.0		78,008	0	0	45,521	123,529	76,887
02-1133	Attorney IV	FT	A	XE	Anchorage	N00	24E / F	12.0		103,558	0	0	54,310	157,868	157,868
02-1134	Attorney IV	FT	A	XE	Anchorage	N00	24F	12.0		106,451	0	0	55,305	161,756	161,756
02-1135	Paralegal II	FT	A	GP	Juneau	205	16A / B	12.0		55,938	752	0	38,033	94,723	94,723
02-1201	Public Defender	FT	A	XE	Anchorage	N00	27M / N	12.0		143,184	0	0	67,918	211,102	161,868
02-1202	Administrative Assistant III	FT	A	SS	Anchorage	600	15E / F	12.0		59,342	0	0	39,244	98,586	98,586
02-1203	Law Office Assistant I	FT	A	GP	Anchorage	200	11C / D	12.0		40,066	538	0	32,573	73,177	73,177
02-1204	Law Office Assistant II	FT	A	GP	Ketchikan	200	13B / C	12.0		44,134	593	0	33,972	78,699	78,699
02-1205	Law Office Assistant I	FT	A	GP	Anchorage	200	11D / E	12.0		40,986	551	0	32,889	74,426	74,426
02-1206	Attorney V	FT	A	XE	Fairbanks	N03	25L	12.0		129,714	0	0	63,308	193,022	193,022
02-1207	Attorney III	FT	A	XE	Juneau	N05	22D / E	12.0		93,256	0	0	50,766	144,022	144,022
02-1208	Attorney III	FT	A	XE	Sitka	N05	22E / F	12.0		95,480	0	0	51,531	147,011	147,011
02-1209	Attorney V	FT	A	XE	Fairbanks	N03	25F	12.0		117,858	0	0	59,229	177,087	177,087
02-1210	Attorney V	FT	A	XE	Anchorage	N00	25P / Q	12.0		145,257	0	0	68,504	213,761	213,761
02-1211	Attorney V	FT	A	XE	Anchorage	N00	25P	12.0		143,130	0	0	67,903	211,033	211,033
02-1212	Investigator III	FT	A	SS	Anchorage	600	18E / F	12.0		72,350	0	0	43,719	116,069	116,069
02-1213	Paralegal I	FT	A	GP	Anchorage	200	14A / B	12.0		46,175	621	0	34,675	81,471	81,471
02-1214	Law Office Assistant I	FT	A	GP	Anchorage	200	11B / C	12.0		38,626	519	0	32,078	71,223	71,223
02-1215	Law Office Assistant II	FT	A	SS	Fairbanks	603	13C / D	12.0		50,234	0	0	36,111	86,345	86,345
02-1216	Attorney I	FT	A	XE	Fairbanks	N03	18E / F	12.0		72,752	0	0	43,713	116,465	116,465

Note: If a position is split, an asterisk (\*) will appear in the Split/Count column. If the split position is also counted in the component, two asterisks (\*\*) will appear in this column. [No valid job title] appearing in the Job Class Title indicates that the PCN has an invalid class code or invalid range for the class code effective date of this scenario.

**Personal Services Expenditure Detail**  
**Department of Administration**

**Scenario:** FY2022 Governor (17280)  
**Component:** Public Defender Agency (1631)  
**RDU:** Legal and Advocacy Services (11)

PCN	Job Class Title	Time Status	Retire Code	Barg Unit	Location	Salary Sched	Range / Step	Comp Months	Split / Count	Annual Salaries	COLA	Premium Pay	Annual Benefits	Total Costs	UGF Amount
02-1217	Investigator I	FT	A	GP	Ketchikan	200	14D / E	12.0		50,128	674	0	36,034	86,836	86,836
02-1218	Attorney IV	FT	A	XE	Anchorage	N00	24B / C	12.0		93,990	0	0	51,019	145,009	145,009
02-1219	Investigator III	FT	A	GP	Fairbanks	203	18C / D	12.0		66,554	894	0	41,685	109,133	109,133
02-1220	Attorney VI	FT	A	XE	Anchorage	N00	26Q	12.0		153,075	0	0	70,714	223,789	223,789
02-1221	Attorney V	FT	A	XE	Anchorage	99	25R	12.0		157,075	0	0	71,845	228,920	228,920
02-1222	Attorney V	FT	A	XE	Anchorage	N00	25K	12.0		121,973	0	0	60,645	182,618	182,618
02-1223	Attorney II	FT	A	XE	Kenai	N00	20E / F	12.0		79,093	0	0	45,894	124,987	124,987
02-1224	Attorney III	FT	A	XE	Anchorage	N00	22A / B	12.0		81,127	0	0	46,594	127,721	127,721
02-1225	Attorney V	FT	A	XE	Anchorage	99	25O	12.0		140,657	0	0	67,072	207,729	207,729
02-1226	Attorney VI	FT	A	XE	Anchorage	N00	26F / J	12.0		121,095	0	0	60,343	181,438	181,438
02-1227	Law Office Assistant I	FT	A	GP	Anchorage	200	11B / C	12.0		39,041	525	0	32,220	71,786	71,786
02-1228	Law Office Assistant I	FT	A	GP	Anchorage	200	11B / C	12.0		39,050	525	0	32,224	71,799	71,799
02-1229	Law Office Assistant I	FT	A	GP	Kenai	200	11D / E	12.0		40,929	550	0	32,870	74,349	74,349
02-1230	Attorney V	FT	A	XE	Anchorage	N00	25E / F	12.0		113,055	0	0	57,577	170,632	170,632
02-1231	Attorney IV	FT	A	XE	Anchorage	N00	24E / F	12.0		105,004	0	0	54,808	159,812	159,812
02-1232	Accounting Technician II	FT	A	GP	Anchorage	200	14G / J	12.0		57,372	771	0	38,526	96,669	96,669
02-1234	Attorney II	FT	A	XE	Anchorage	N00	20D / E	12.0		76,762	0	0	45,092	121,854	121,854
02-1235	Attorney IV	FT	A	XE	Fairbanks	N03	24D / E	12.0		104,070	0	0	54,486	158,556	158,556
02-1236	Attorney V	FT	A	XE	Anchorage	99	25R / S	12.0		161,329	0	0	73,048	234,377	234,377
02-1238	Attorney IV	FT	A	XE	Ketchikan	N00	24F / J	12.0		107,313	0	0	55,602	162,915	162,915
02-1239	Attorney III	FT	A	XE	Fairbanks	N03	22E / F	12.0		92,568	0	0	50,530	143,098	143,098
02-1240	Attorney IV	FT	A	XE	Fairbanks	N03	24F	12.0		109,649	0	0	56,406	166,055	129,350
02-1242	Attorney IV	FT	A	XE	Juneau	N05	24Q / R	12.0		146,309	0	0	68,801	215,110	215,110
02-1243	Attorney I	FT	A	XE	Anchorage	N00	18E / F	12.0		70,794	0	0	43,039	113,833	113,833
02-1244	Law Office Assistant I	FT	A	GP	Anchorage	200	11C / D	12.0		39,965	537	0	32,538	73,040	73,040
02-1245	Paralegal I	FT	A	GP	Bethel	250	14A / B	12.0		69,328	932	0	42,639	112,899	112,899
02-1246	Attorney III	FT	A	XE	Bethel	N50	22B / C	12.0		124,816	0	0	61,623	186,439	186,439
02-1247	Attorney V	FT	A	XE	Juneau	99	25S	12.0		171,117	0	0	75,815	246,932	246,932
02-1248	Attorney II	FT	A	XE	Kenai	N00	20D / E	12.0		78,238	0	0	45,600	123,838	123,838
02-1249	Attorney III	FT	A	XE	Anchorage	N00	22B / C	12.0		82,225	0	0	46,972	129,197	82,497
02-1250	Paralegal II	FT	A	GP	Anchorage	200	16D / E	12.0		58,403	785	0	38,881	98,069	98,069
02-1251	Attorney V	FT	A	XE	Kenai	N00	25J / K	12.0		120,052	0	0	59,984	180,036	180,036
02-1253	Attorney I	FT	A	XE	Nome	N37	18F / F	12.0		97,637	0	0	52,273	149,910	149,910
02-1254	Law Office Assistant II	FT	A	GP	Anchorage	200	13B	12.0		43,544	585	0	33,769	77,898	77,898
02-1255	Law Office Assistant II	FT	A	GP	Kotzebue	260	13C / D	12.0		74,607	1,003	0	44,455	120,065	120,065
02-1256	Attorney IV	FT	A	XE	Anchorage	N00	24D / E	12.0		102,289	0	0	53,874	156,163	156,163
02-1258	Paralegal I	FT	A	GP	Utqiagvik	250	14J	12.0		86,639	1,164	0	48,594	136,397	136,397
02-1259	Law Office Assistant I	FT	A	GP	Fairbanks	203	11C / D	12.0		41,009	551	0	32,897	74,457	74,457

Note: If a position is split, an asterisk (\*) will appear in the Split/Count column. If the split position is also counted in the component, two asterisks (\*\*) will appear in this column. [No valid job title] appearing in the Job Class Title indicates that the PCN has an invalid class code or invalid range for the class code effective date of this scenario.

**Personal Services Expenditure Detail**  
**Department of Administration**

**Scenario:** FY2022 Governor (17280)  
**Component:** Public Defender Agency (1631)  
**RDU:** Legal and Advocacy Services (11)

PCN	Job Class Title	Time Status	Retire Code	Barg Unit	Location	Salary Sched	Range / Step	Comp Months	Split / Count	Annual Salaries	COLA	Premium Pay	Annual Benefits	Total Costs	UGF Amount
02-1260	Attorney III	FT	A	XE	Fairbanks	N03	22C / D	12.0		88,485	0	0	49,125	137,610	101,065
02-1261	Attorney III	FT	A	XE	Fairbanks	N03	22B / C	12.0		83,919	0	0	47,554	131,473	131,473
02-1262	Attorney III	FT	A	XE	Juneau	N05	22E / F	12.0		95,087	0	0	51,396	146,483	73,281
02-1263	Attorney III	FT	A	XE	Anchorage	N00	22C / D	12.0		85,283	0	0	48,024	133,307	133,307
02-1264	Attorney IV	FT	A	XE	Anchorage	N00	24F / J	12.0		109,758	0	0	56,443	166,201	166,201
02-1265	Attorney II	FT	A	XE	Juneau	N05	20C / D	12.0		79,942	0	0	46,186	126,128	126,128
02-1266	Attorney III	FT	A	XE	Palmer	N00	22B / C	12.0		82,537	0	0	47,079	129,616	129,616
02-1267	Attorney IV	FT	A	XE	Fairbanks	N03	24L	12.0		120,686	0	0	60,202	180,888	180,888
02-1268	Investigator III	FT	A	GP	Nome	237	18C / D	12.0		89,657	1,205	0	49,632	140,494	140,494
02-1269	Attorney IV	FT	A	XE	Juneau	N05	24F	12.0		111,774	0	0	57,137	168,911	168,911
02-1270	Attorney IV	FT	A	XE	Palmer	99	24O / P	12.0		134,940	0	0	65,106	200,046	200,046
02-1271	Paralegal II	FT	A	GP	Anchorage	200	16B / C	12.0		55,077	740	0	37,737	93,554	93,554
02-1272	Attorney I	FT	A	XE	Anchorage	N00	18E / F	12.0		70,728	0	0	43,017	113,745	113,745
02-1273	Law Office Assistant II	FT	A	GP	Kodiak	211	13D / E	12.0		53,344	717	0	37,141	91,202	91,202
02-1274	Law Office Assistant I	FT	A	GP	Anchorage	200	11C / D	12.0		40,368	543	0	32,677	73,588	73,588
02-1275	Investigator III	FT	A	GP	Anchorage	200	18B / C	12.0		61,845	831	0	40,065	102,741	102,741
02-1276	Attorney IV	FT	A	XE	Fairbanks	N03	24D / E	12.0		103,899	0	0	54,428	158,327	158,327
02-1277	Attorney IV	FT	A	XE	Anchorage	N00	24K	12.0		113,490	0	0	57,727	171,217	171,217
02-1278	Attorney VI	FT	A	XE	Anchorage	N00	26O	12.0		143,598	0	0	68,035	211,633	211,633
02-1279	Attorney IV	FT	A	XE	Anchorage	99	24M	12.0		121,568	0	0	60,506	182,074	182,074
02-1280	Attorney IV	FT	A	XE	Anchorage	N00	24K / L	12.0		116,868	0	0	58,889	175,757	175,757
02-1281	Office Assistant II	PT	A	GP	Anchorage	99	10P	8.0		36,241	487	0	18,730	55,458	55,458
02-1282	Attorney III	FT	A	XE	Anchorage	N00	22C / D	12.0		86,044	0	0	48,285	134,329	134,329
02-1283	Paralegal I	FT	A	GP	Sitka	205	14N	12.0		68,913	926	0	42,496	112,335	112,335
02-1284	Attorney I	FT	A	XE	Palmer	N00	18E / F	12.0		70,728	0	0	43,017	113,745	113,745
02-1286	Associate Attorney I	FT	A	XE	Fairbanks	N03	17J / K	12.0		72,166	0	0	43,511	115,677	115,677
02-1287	Investigator III	FT	A	SS	Bethel	99	18R / S	12.0		162,157	0	0	73,426	235,583	235,583
02-1288	Investigator III	FT	A	GP	Fairbanks	203	18B / C	12.0		64,701	870	0	41,047	106,618	106,618
02-1289	Paralegal II	FT	A	GP	Anchorage	200	16B / C	12.0		54,643	734	0	37,588	92,965	92,965
02-1290	Attorney II	FT	A	XE	Anchorage	N00	20C / D	12.0		75,716	0	0	44,733	120,449	120,449
02-1291	Attorney I	FT	A	XE	Anchorage	N00	18F / F	12.0		71,273	0	0	43,204	114,477	114,477
02-1292	Attorney IV	FT	A	XE	Palmer	N00	24F / J	12.0		108,032	0	0	55,849	163,881	163,881
02-1293	Attorney V	FT	A	XE	Ketchikan	N00	25E / F	12.0		110,586	0	0	56,728	167,314	167,314
02-1296	Attorney IV	FT	A	XE	Kenai	N00	24K	12.0		113,490	0	0	57,727	171,217	171,217
02-1297	Law Office Assistant II	FT	A	SS	Anchorage	600	13B / C	12.0		47,450	0	0	35,153	82,603	82,603
02-1298	Attorney VI	FT	A	XE	Anchorage	99	26R	12.0		162,701	0	0	73,435	236,136	236,136
02-1299	Attorney II	FT	A	XE	Kenai	N00	20D / E	12.0		76,378	0	0	44,960	121,338	121,338
02-1300	Attorney IV	FT	A	XE	Nome	N37	24D / E	12.0		139,555	0	0	66,693	206,248	206,248

Note: If a position is split, an asterisk (\*) will appear in the Split/Count column. If the split position is also counted in the component, two asterisks (\*\*) will appear in this column. [No valid job title] appearing in the Job Class Title indicates that the PCN has an invalid class code or invalid range for the class code effective date of this scenario.

**Personal Services Expenditure Detail**  
**Department of Administration**

**Scenario:** FY2022 Governor (17280)  
**Component:** Public Defender Agency (1631)  
**RDU:** Legal and Advocacy Services (11)

PCN	Job Class Title	Time Status	Retire Code	Barg Unit	Location	Salary Sched	Range / Step	Comp Months	Split / Count	Annual Salaries	COLA	Premium Pay	Annual Benefits	Total Costs	UGF Amount
02-1305	Paralegal II	FT	A	SS	Palmer	600	16J / K	12.0		69,672	0	0	42,797	112,469	112,469
02-1320	Law Office Assistant I	FT	A	GP	Palmer	200	11P / Q	12.0		57,036	767	0	38,411	96,214	96,214
02-1321	Law Office Assistant I	FT	A	GP	Anchorage	200	11C / D	12.0		40,016	538	0	32,556	73,110	73,110
02-1322	Attorney IV	FT	A	XE	Fairbanks	N03	24F	12.0		109,649	0	0	56,406	166,055	166,055
02-1323	Attorney I	FT	A	XE	Bethel	N50	18F	12.0		106,899	0	0	55,460	162,359	162,359
02-1324	Administrative Assistant I	FT	A	GP	Anchorage	200	12E / F	12.0		45,790	615	0	34,542	80,947	80,947
02-1325	Attorney III	FT	A	XE	Ketchikan	N00	22C / D	12.0		86,652	0	0	48,495	135,147	135,147
02-1326	Attorney III	FT	A	XE	Anchorage	N00	22B / C	12.0		83,681	0	0	47,473	131,154	131,154
02-1327	Attorney IV	FT	A	XE	Anchorage	N00	24F / J	12.0		109,183	0	0	56,245	165,428	165,428
02-1328	Attorney III	FT	A	XE	Kenai	N00	22B / C	12.0		83,369	0	0	47,365	130,734	130,734
02-1329	Attorney III	FT	A	XE	Kodiak	N11	22C	12.0		93,113	0	0	50,717	143,830	143,830
02-1330	Investigator II	FT	A	GP	Anchorage	200	16C / D	12.0		55,473	746	0	37,873	94,092	94,092
02-1331	Attorney IV	FT	A	XE	Anchorage	99	24M / N	12.0		122,226	0	0	60,732	182,958	182,958
02-1332	Attorney II	FT	A	XE	Palmer	N00	20C / D	12.0		75,626	0	0	44,702	120,328	120,328
02-1333	Attorney I	FT	A	XE	Bethel	N50	18E / F	12.0		106,184	0	0	55,214	161,398	161,398
02-1334	Attorney IV	FT	A	XE	Anchorage	99	24O / P	12.0		134,586	0	0	64,984	199,570	199,570
02-1335	Attorney V	FT	A	XE	Dillingham	N37	25L / M	12.0		175,101	0	0	76,941	252,042	252,042
02-1336	Attorney V	FT	A	XE	Anchorage	N00	25F	12.0		114,426	0	0	58,049	172,475	172,475
02-1338	Law Office Assistant I	FT	A	GP	Anchorage	200	11C / D	12.0		39,965	537	0	32,538	73,040	73,040
02-1339	Attorney IV	FT	A	XE	Anchorage	N00	24F	12.0		106,451	0	0	55,305	161,756	161,756
02-1341	Law Office Assistant I	FT	A	GP	Kenai	200	11G	12.0		45,084	606	0	34,299	79,989	79,989
02-1342	Attorney V	FT	A	XE	Anchorage	99	25P / Q	12.0		150,068	0	0	69,864	219,932	219,932
02-1343	Attorney IV	FT	A	XE	Anchorage	N00	24F	12.0		106,451	0	0	55,305	161,756	161,756
02-1344	Attorney IV	FT	A	XE	Anchorage	N00	24L	12.0		117,176	0	0	58,995	176,171	176,171
02-1345	Paralegal I	FT	A	GP	Anchorage	200	14C / D	12.0		48,259	649	0	35,391	84,299	84,299
02-1346	Attorney II	FT	A	XE	Anchorage	N00	20D / E	12.0		78,104	0	0	45,554	123,658	123,658
02-1347	Paralegal II	FT	A	GP	Anchorage	200	16E / F	12.0		60,605	815	0	39,638	101,058	101,058
02-1348	Attorney IV	FT	A	XE	Anchorage	N00	24C / D	12.0		98,913	0	0	52,712	151,625	104,738
02-1349	Attorney III	FT	A	XE	Fairbanks	N03	22B / C	12.0		86,124	0	0	48,313	134,437	134,437
02-1350	Attorney IV	FT	A	XE	Kenai	N00	24F	12.0		106,451	0	0	55,305	161,756	161,756
02-1351	Associate Attorney II	FT	A	XE	Anchorage	99	19M / N	12.0		88,541	0	0	49,144	137,685	137,685
02-1352	Law Office Assistant I	FT	A	GP	Anchorage	200	11B / C	12.0		39,616	532	0	32,418	72,566	72,566
02-1354	Paralegal I	FT	A	GP	Anchorage	200	14A / B	12.0		46,111	620	0	34,652	81,383	81,383
02-1355	Attorney III	FT	A	XE	Anchorage	N00	22F	12.0		92,957	0	0	50,663	143,620	143,620
02-1357	Law Office Assistant I	FT	A	GP	Anchorage	200	11B / C	12.0		39,041	525	0	32,220	71,786	71,786
02-1358	Attorney III	FT	A	XE	Anchorage	N00	22C / D	12.0		85,664	0	0	48,155	133,819	87,076
02-1359	Attorney III	FT	A	XE	Kenai	N00	22E / F	12.0		91,884	0	0	50,294	142,178	142,178
02-1360	Attorney IV	FT	A	XE	Anchorage	N00	24F	12.0		106,451	0	0	55,305	161,756	161,756

Note: If a position is split, an asterisk (\*) will appear in the Split/Count column. If the split position is also counted in the component, two asterisks (\*\*) will appear in this column. [No valid job title] appearing in the Job Class Title indicates that the PCN has an invalid class code or invalid range for the class code effective date of this scenario.

**Personal Services Expenditure Detail**  
**Department of Administration**

**Scenario:** FY2022 Governor (17280)  
**Component:** Public Defender Agency (1631)  
**RDU:** Legal and Advocacy Services (11)

PCN	Job Class Title	Time Status	Retire Code	Barg Unit	Location	Salary Sched	Range / Step	Comp Months	Split / Count	Annual Salaries	COLA	Premium Pay	Annual Benefits	Total Costs	UGF Amount
02-1361	Attorney III	FT	A	XE	Bethel	N50	22B / C	12.0		125,034	0	0	61,698	186,732	186,732
02-1362	Investigator III	FT	A	GP	Anchorage	200	18F / G	12.0		70,898	953	0	43,179	115,030	115,030
02-1363	Attorney IV	FT	A	XE	Palmer	N00	24C / D	12.0		98,612	0	0	52,609	151,221	97,499
02-1364	Administrative Officer I	FT	A	SS	Anchorage	200	17F	12.0		70,699	0	0	43,151	113,850	113,850
02-1365	Paralegal I	FT	A	GP	Fairbanks	203	14B / C	12.0		49,388	664	0	35,780	85,832	85,832
02-1366	Paralegal I	FT	A	GP	Kenai	200	14D / E	12.0		51,474	692	0	36,497	88,663	88,663
02-1367	Paralegal II	FT	A	GP	Anchorage	200	16G / J	12.0		66,203	890	0	41,564	108,657	108,657
02-1370	Paralegal II	FT	A	GP	Palmer	200	16D / E	12.0		58,139	781	0	38,790	97,710	97,710
02-1371	Paralegal II	FT	A	GP	Anchorage	200	16D / E	12.0		57,876	778	0	38,700	97,354	97,354
02-1372	Investigator III	FT	A	SS	Kenai	600	18J	12.0		77,355	0	0	45,440	122,795	122,795
02-1373	Associate Attorney I	FT	A	XE	Bethel	N50	17J / K	12.0		104,952	0	0	54,790	159,742	79,871
02-1374	Associate Attorney I	FT	A	XE	Anchorage	N00	17E / F	12.0		64,864	0	0	41,000	105,864	105,864
02-1375	Attorney IV	FT	A	XE	Anchorage	N00	24F	12.0		106,451	0	0	55,305	161,756	161,756
02-1376	Attorney IV	FT	A	XE	Anchorage	N00	24K / L	12.0		116,561	0	0	58,783	175,344	175,344
02-1377	Attorney IV	FT	A	XE	Anchorage	N00	24K / L	12.0		116,561	0	0	58,783	175,344	175,344
02-1378	Paralegal I	FT	A	SS	Anchorage	600	14A / B	12.0		48,774	0	0	35,609	84,383	84,383
02-1379	Associate Attorney I	FT	A	XE	Anchorage	N00	17E / F	12.0		65,501	0	0	41,219	106,720	106,720
02-1380	Attorney III	FT	A	XE	Anchorage	N00	22C / D	12.0		84,396	0	0	47,718	132,114	85,387
02-1381	Attorney IV	FT	A	XE	Anchorage	N00	24F	12.0		106,451	0	0	55,305	161,756	161,756
02-1382	Attorney IV	FT	A	XE	Bethel	N50	24F	12.0		159,686	0	0	72,583	232,269	232,269
02-1383	Attorney III	FT	A	XE	Fairbanks	N03	22E / F	12.0		94,226	0	0	51,100	145,326	145,326
02-1384	Attorney I	FT	A	XE	Dillingham	N37	18F	12.0		97,637	0	0	52,273	149,910	149,910
02-1385	Attorney II	FT	A	XE	Kodiak	N11	20C / D	12.0		84,248	0	0	47,668	131,916	131,916
02-1386	Attorney II	FT	A	XE	Anchorage	N00	20C / D	12.0		75,581	0	0	44,686	120,267	120,267
02-1388	Attorney IV	FT	A	XE	Ketchikan	N00	24F / J	12.0		107,889	0	0	55,800	163,689	163,689
02-1389	Attorney I	FT	A	XE	Fairbanks	N03	18E / F	12.0		73,398	0	0	43,935	117,333	117,333
02-1390	Law Office Assistant I	FT	A	GP	Fairbanks	203	11C / D	12.0		41,009	551	0	32,897	74,457	74,457
02-1391	Law Office Assistant I	FT	A	GP	Juneau	205	11B / C	12.0		41,503	558	0	33,067	75,128	75,128
02-1392	Law Office Assistant II	FT	A	SS	Anchorage	600	13E / F	12.0		52,140	0	0	36,766	88,906	88,906
02-1393	Paralegal I	FT	A	GP	Anchorage	200	14B / C	12.0		47,600	640	0	35,165	83,405	83,405
02-1394	Paralegal I	FT	A	GP	Nome	237	14B / C	12.0		65,689	883	0	41,387	107,959	107,959
02-1395	Paralegal I	FT	A	GP	Anchorage	200	14A / B	12.0		46,111	620	0	34,652	81,383	81,383
02-1396	Associate Attorney I	FT	A	XE	Anchorage	N00	17D / E	12.0		63,783	0	0	40,628	104,411	104,411
02-N07006	Law Office Assistant II	NP	N	GP	Ketchikan	200	13A	0.5		1,760	19	0	178	1,957	1,957
02-N07033	Law Office Assistant I	NP	N	GP	Kenai	200	11A	0.5		1,561	17	0	158	1,736	1,736
02-N07035	Law Office Assistant I	NP	N	GP	Anchorage	200	11A	3.0		7,135	79	0	720	7,934	7,934
02-N07037	Law Office Assistant I	NP	N	GP	Kodiak	211	11A	0.5		1,732	19	0	175	1,926	1,926
02-N07039	Law Office Assistant I	NP	N	GP	Palmer	200	11A	0.5		250	3	0	25	278	278

Note: If a position is split, an asterisk (\*) will appear in the Split/Count column. If the split position is also counted in the component, two asterisks (\*\*) will appear in this column. [No valid job title] appearing in the Job Class Title indicates that the PCN has an invalid class code or invalid range for the class code effective date of this scenario.

**Personal Services Expenditure Detail**  
**Department of Administration**

**Scenario:** FY2022 Governor (17280)  
**Component:** Public Defender Agency (1631)  
**RDU:** Legal and Advocacy Services (11)

PCN	Job Class Title	Time Status	Retire Code	Barg Unit	Location	Salary Sched	Range / Step	Comp Months	Split / Count	Annual Salaries	COLA	Premium Pay	Annual Benefits	Total Costs	UGF Amount
02-N07043	Law Office Assistant I	NP	N	GP	Fairbanks	203	11A	0.5		990	11	0	100	1,101	1,101
02-N19013	Law Office Assistant I	NP	N	GP	Bethel	250	11A	0.5		216	2	0	22	240	240
02-N19019	Law Office Assistant I	NP	N	GP	Nome	237	11A	0.5		987	11	0	100	1,098	1,098
02-TPX002	Attorney I	NP	N	XE	Anchorage	N00	18F	12.0		71,273	0	0	7,191	78,464	78,464
													<b>Total Salary Costs:</b>	16,295,803	
													<b>Total COLA:</b>	43,045	
													<b>Total Premium Pay:</b>	0	
													<b>Total Benefits:</b>	9,021,984	
													<b>Total Pre-Vacancy:</b>	25,360,832	
													<b>Minus Vacancy Adjustment of 4.40%:</b>	(1,115,832)	
													<b>Total Post-Vacancy:</b>	24,245,000	
													<b>Plus Lump Sum Premium Pay:</b>	0	
													<b>Personal Services Line 100:</b>	24,245,000	
<b>Total Component Months:</b>		2,234.5													

<b>PCN Funding Sources:</b>	<b>Pre-Vacancy</b>	<b>Post-Vacancy</b>	<b>Percent</b>
1004 General Fund Receipts	24,505,612	23,427,408	96.63%
1007 Interagency Receipts	483,108	461,852	1.90%
1037 General Fund / Mental Health	292,241	279,383	1.15%
1092 Mental Health Trust Authority Authorized Receipts	79,871	76,357	0.31%
<b>Total PCN Funding:</b>	<b>25,360,832</b>	<b>24,245,000</b>	<b>100.00%</b>

Note: If a position is split, an asterisk (\*) will appear in the Split/Count column. If the split position is also counted in the component, two asterisks (\*\*) will appear in this column. [No valid job title] appearing in the Job Class Title indicates that the PCN has an invalid class code or invalid range for the class code effective date of this scenario.



**Department of Administration**  
 Public Defender Agency (1631)  
 RDU: Legal & Advocacy Services (11)  
 FY2022 Governor's Budget  
 Position Totals: 184 PFT | 1 PPT | 9 NP

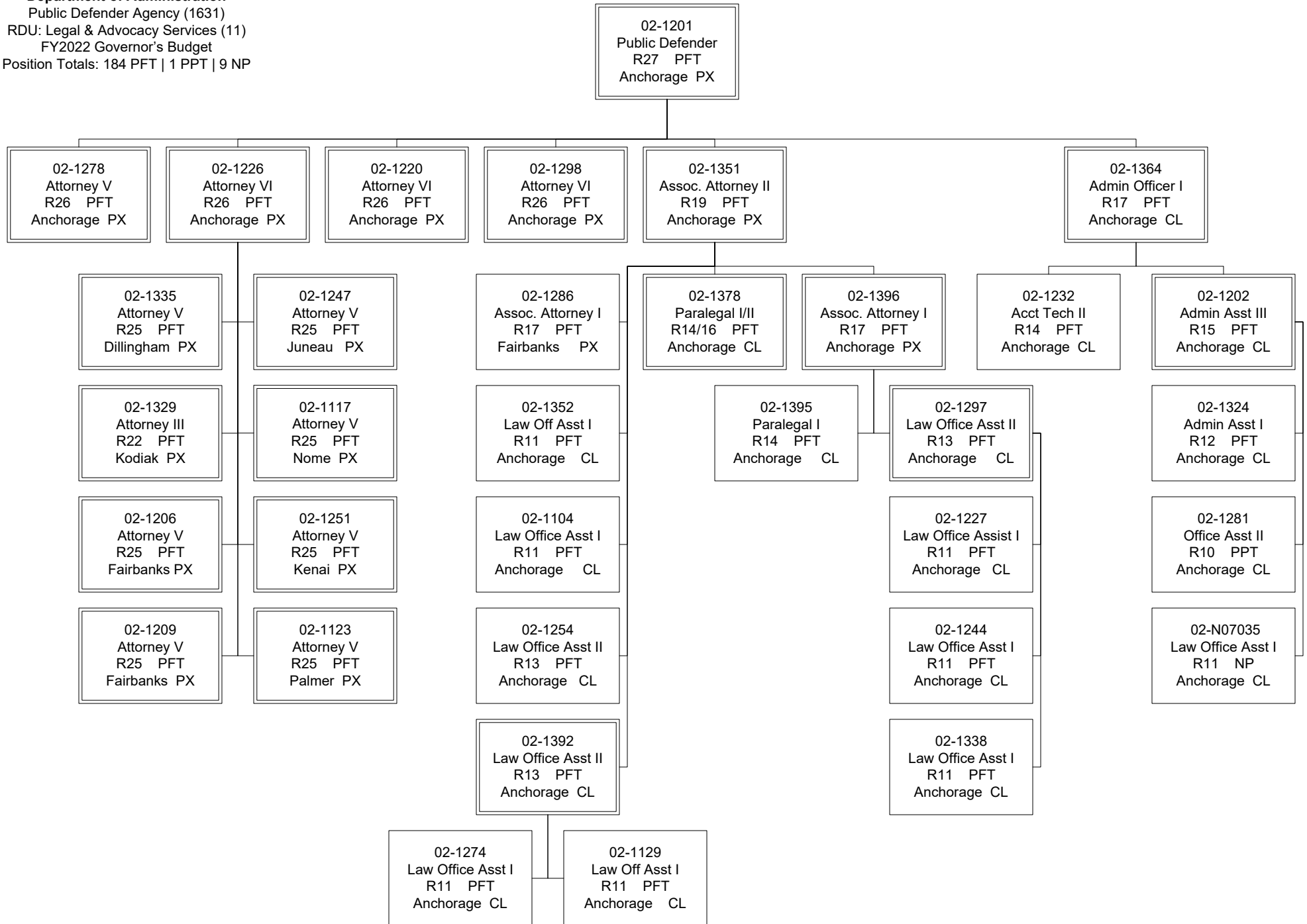

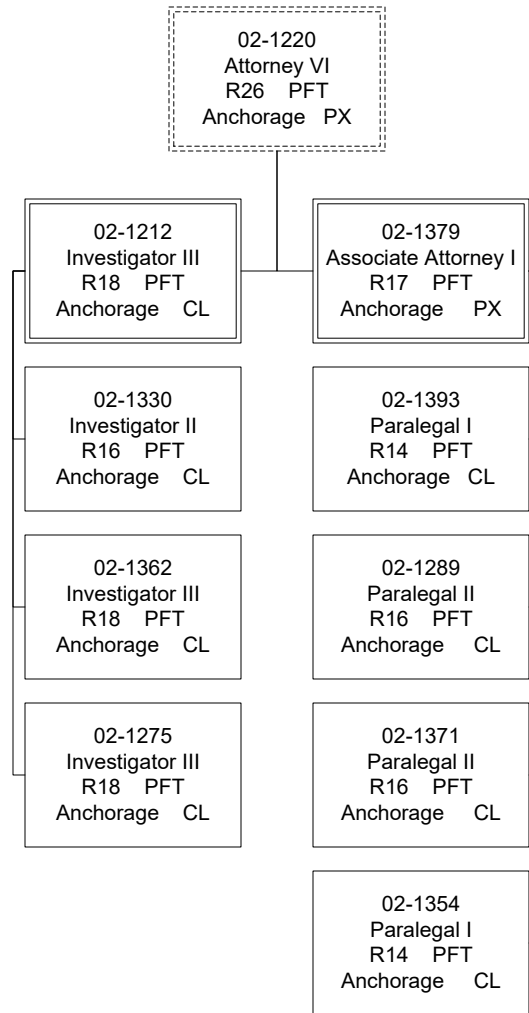

Department of Administration  
 Public Defender Agency (1631)  
 Anchorage Criminal Section

02-1220  
 Attorney VI  
 R26 PFT  
 Anchorage PX

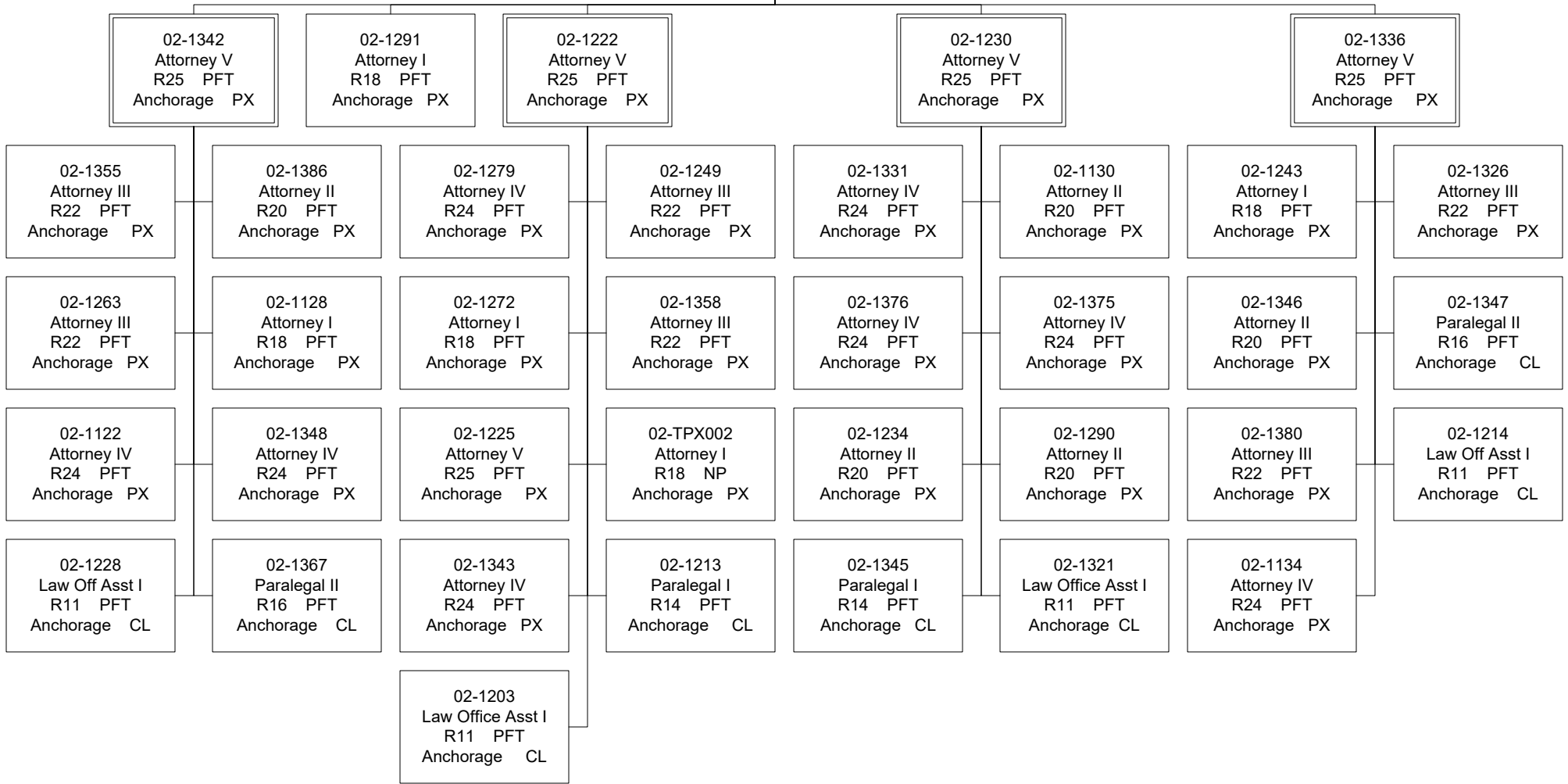

Department of Administration  
Public Defender Agency (1631)  
*Appeals*

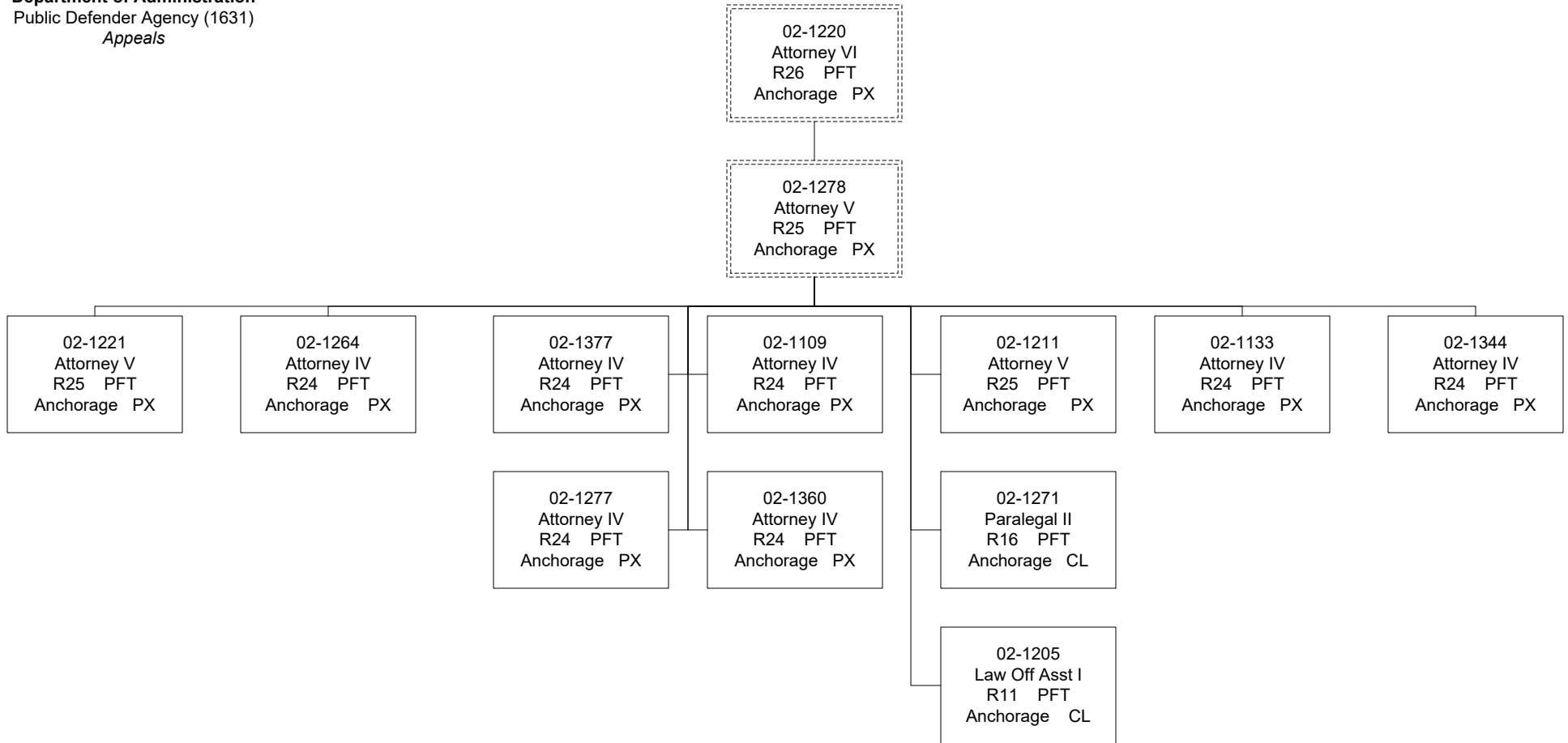

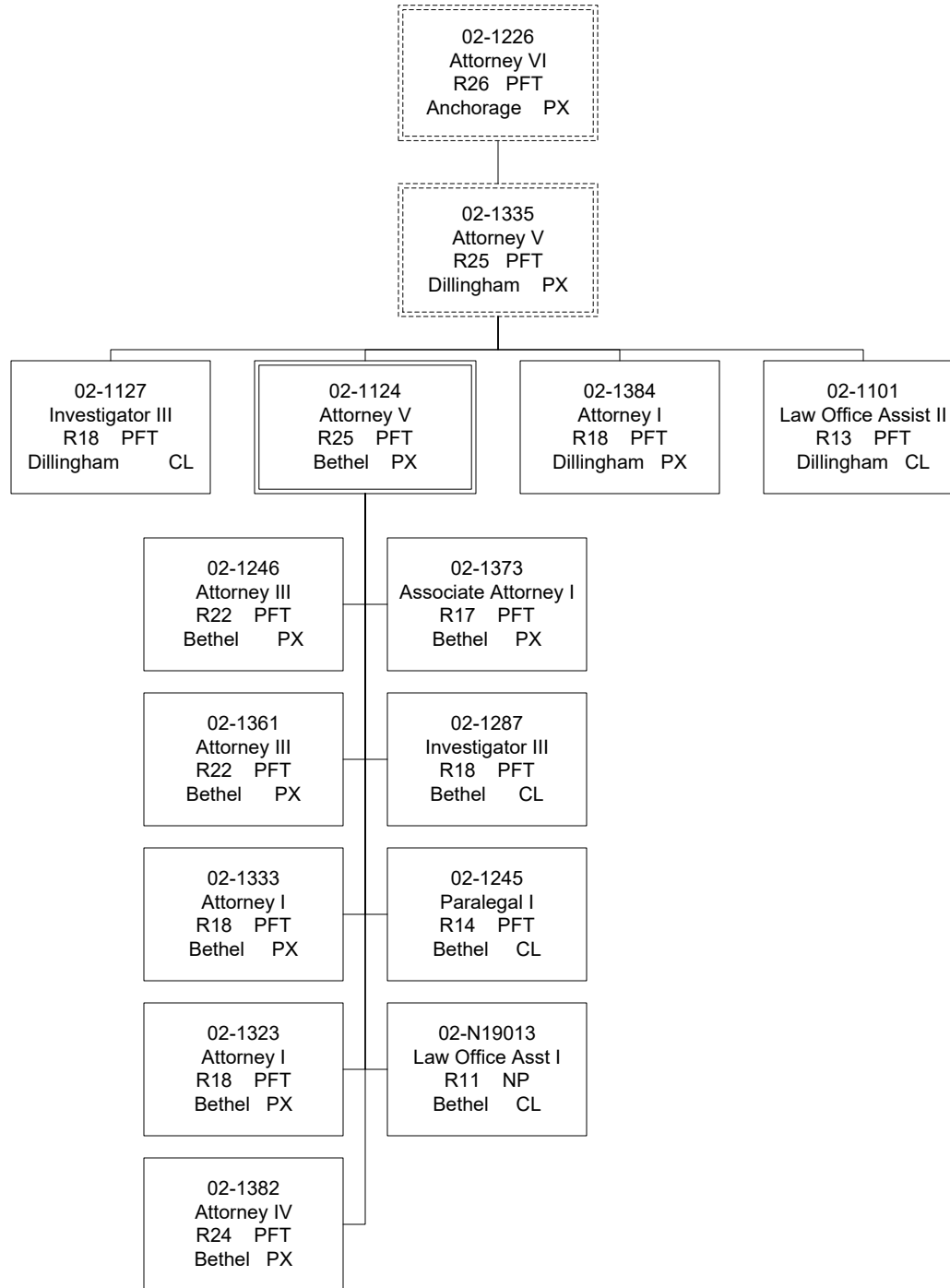

Department of Administration  
Public Defender Agency (1631)  
Civil Section

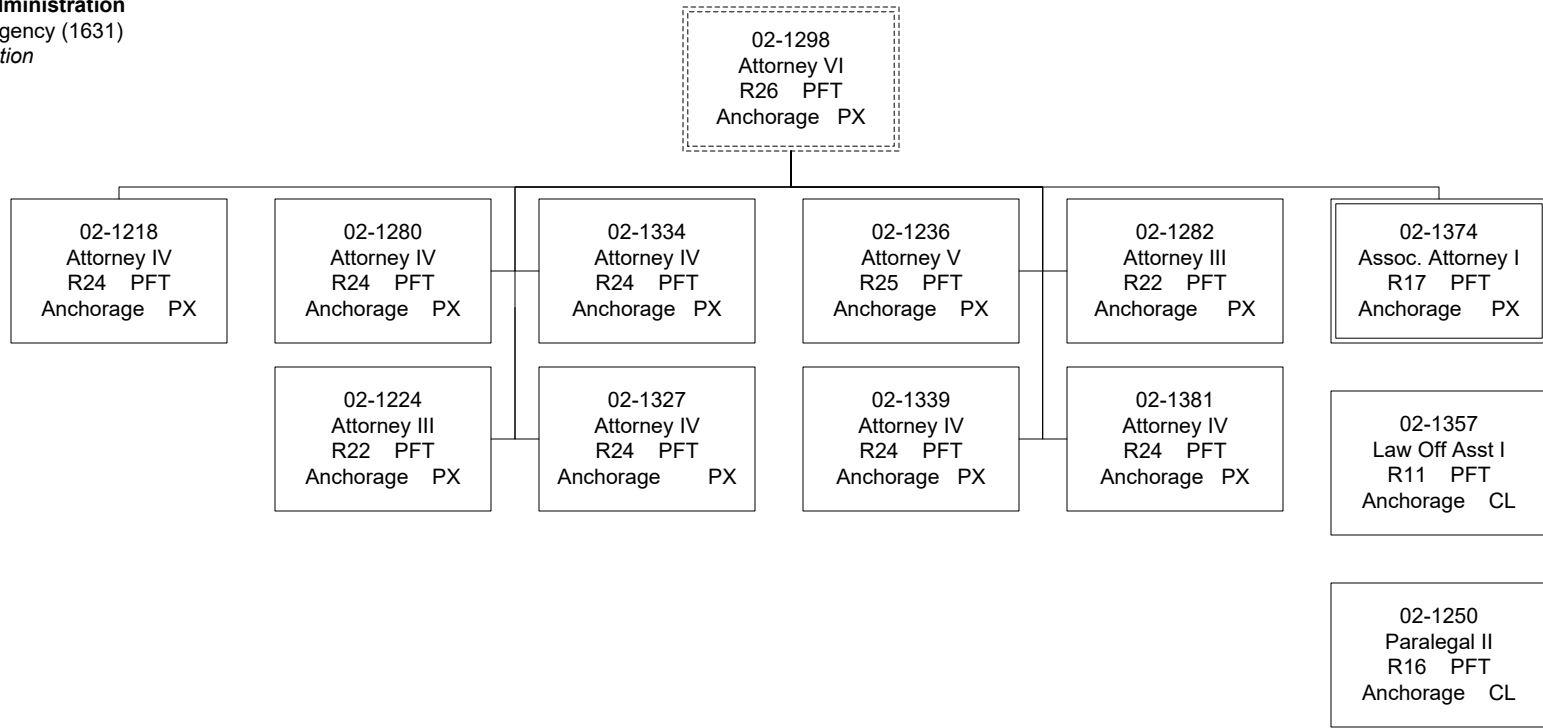

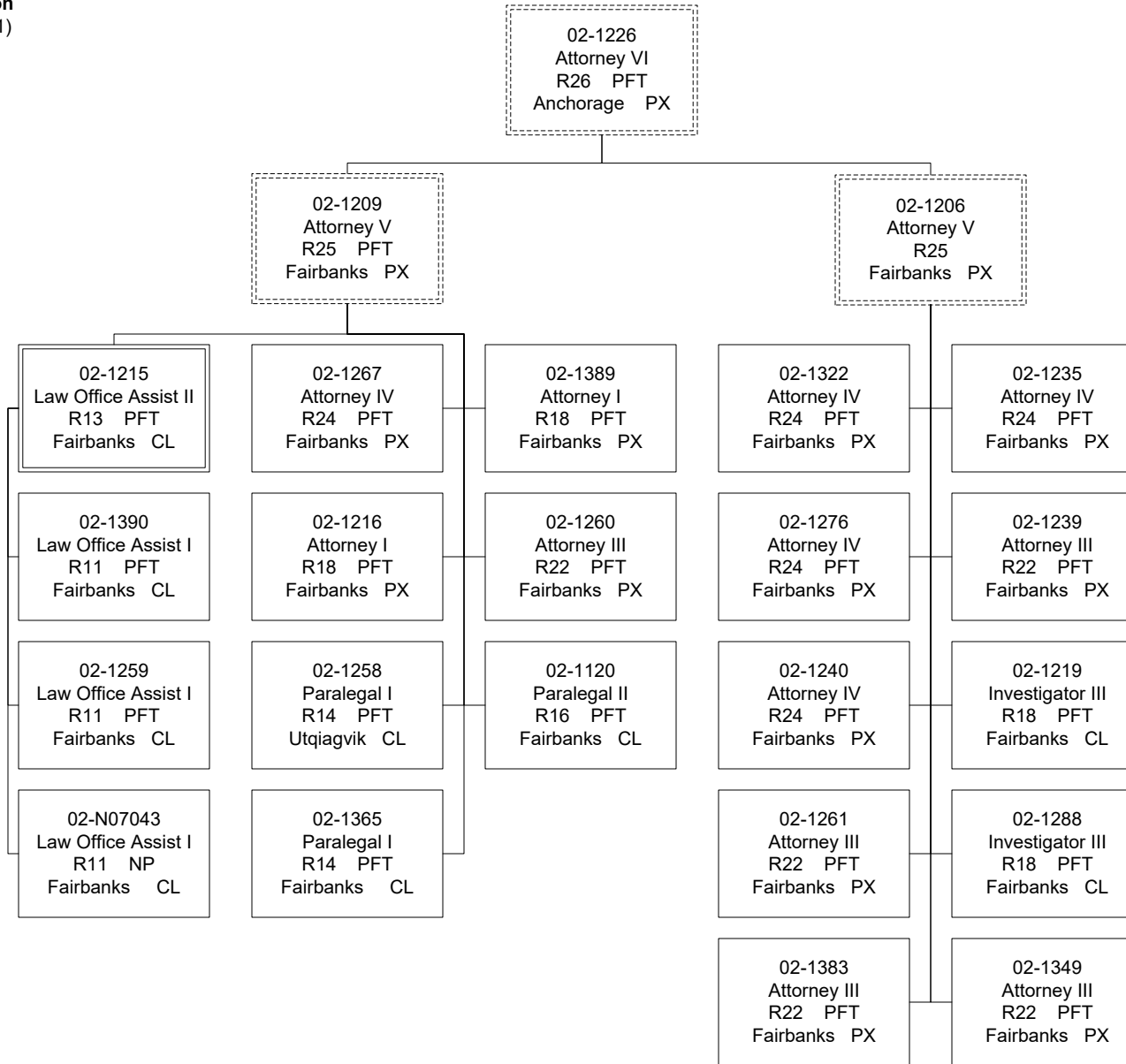

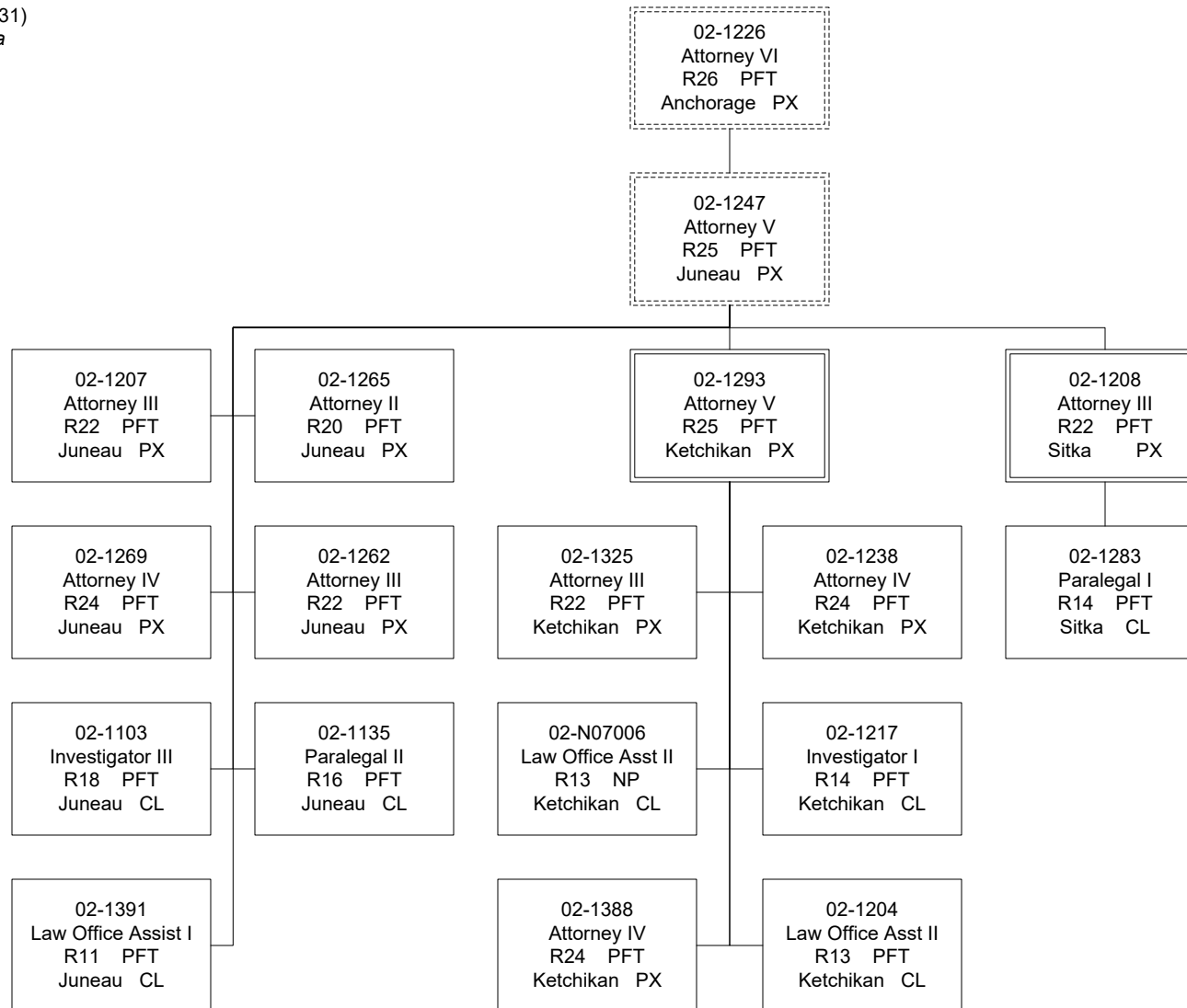



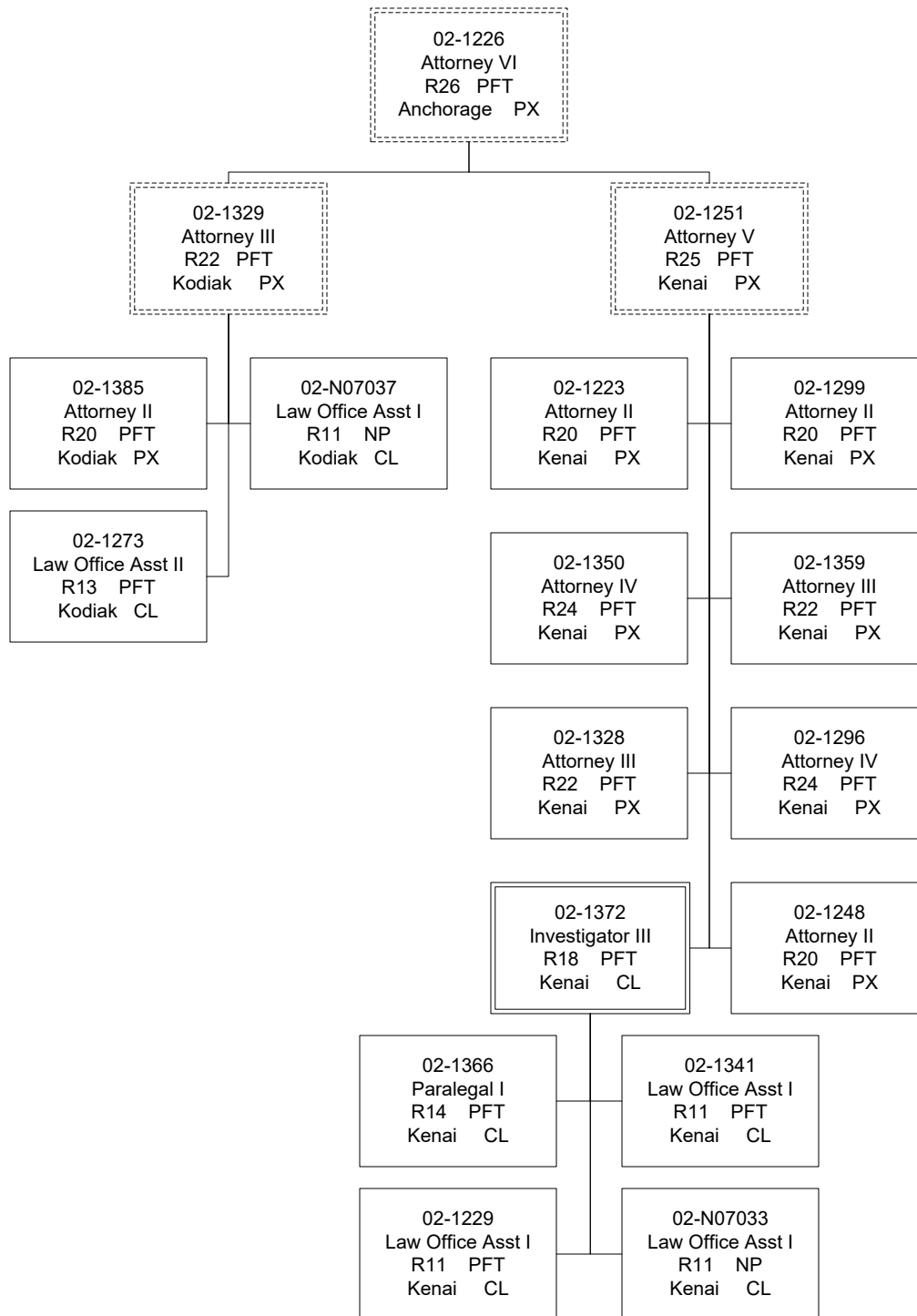

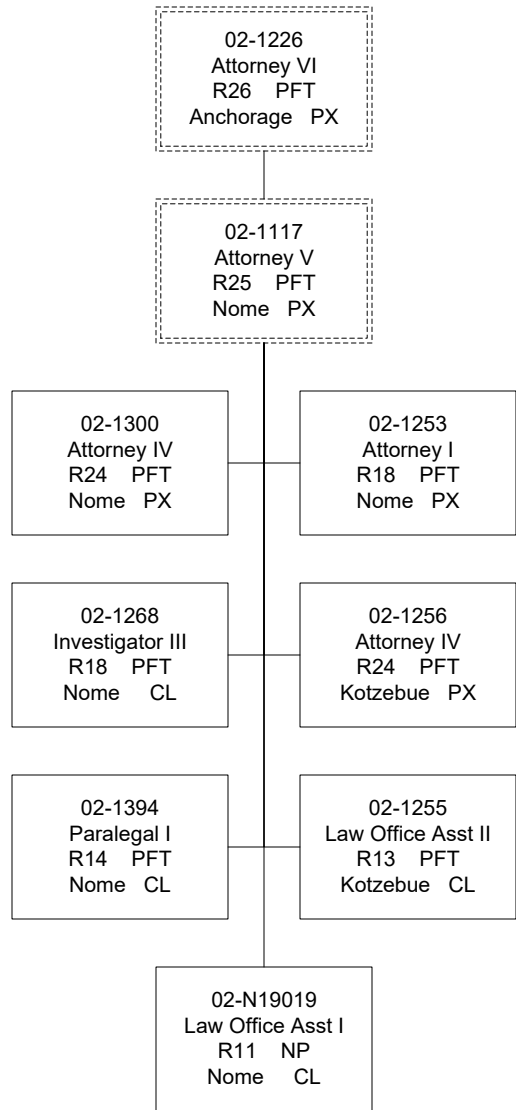

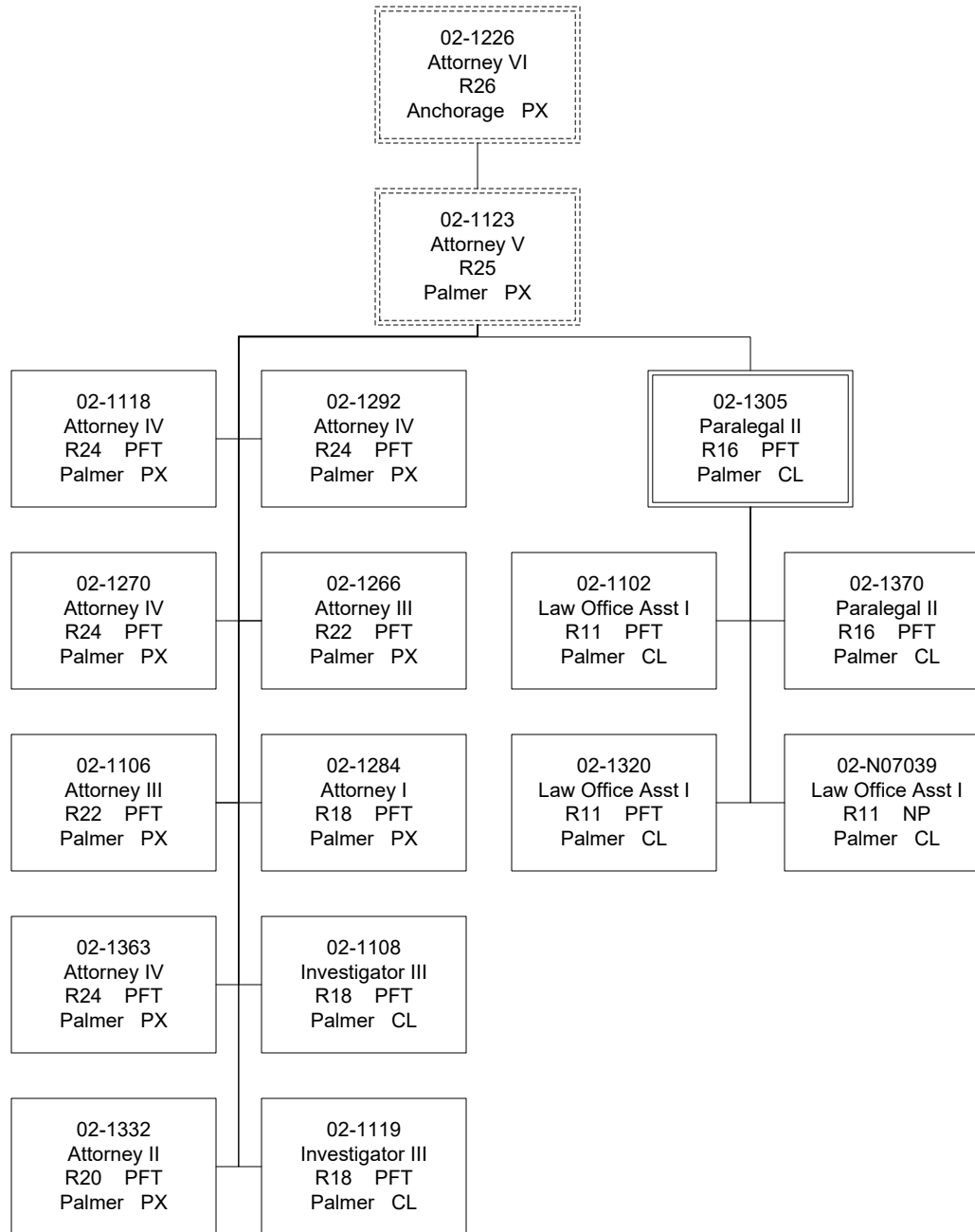

Department of Administration  
Public Defender Agency (1631)  
*Traveling Section*

