

State of Alaska
FY2022 Governor's Operating Budget

Department of Law
Office of the Attorney General
Component Budget Summary

Component: Office of the Attorney General

Contribution to Department's Mission

The Attorney General is the state's chief law enforcement officer, overseeing the state's involvement in all civil matters and criminal prosecutions, and leading over 500 attorneys and staff in the Department of Law's twelve offices throughout the state. The Attorney General serves as co-chair with the Chief Justice of the Alaska Supreme Court of the Alaska Criminal Justice Working Group and trustee on the Exxon Valdez Oil Spill Trustee Council.

Core Services

- Protecting the safety and physical and financial well-being of Alaskans.
- Fostering the conditions for economic opportunity and for the responsible development and use of our natural resources.
- Protecting the fiscal integrity of the State of Alaska.
- Promoting and defending good governance.

Major Component Accomplishments in 2020

Major accomplishments are shown at the department level.

Key Component Challenges

Key component challenges are shown at the department level.

Significant Changes in Results to be Delivered in FY2022

Changes in results are shown at the department level.

Statutory and Regulatory Authority

AS 44.23.020

Contact Information

Contact: Ed Sniffen, Acting Attorney General
Phone: (907) 269-5100
E-mail: ed.sniffen@alaska.gov

Office of the Attorney General Personal Services Information				
Authorized Positions			Personal Services Costs	
	<u>FY2021</u> <u>Management</u> <u>Plan</u>	<u>FY2022</u> <u>Governor</u>		
Full-time	5	5	Annual Salaries	584,348
Part-time	0	0	Premium Pay	0
Nonpermanent	0	0	Annual Benefits	290,347
			<i>Less 0.71% Vacancy Factor</i>	(6,195)
			Lump Sum Premium Pay	0
Totals	5	5	Total Personal Services	868,500

Position Classification Summary					
Job Class Title	Anchorage	Fairbanks	Juneau	Others	Total
Commissioner	1	0	0	0	1
Deputy Attorney General	1	0	0	0	1
Executive Secretary III	1	0	0	0	1
Sp Asst Commrrii	2	0	0	0	2
Totals	5	0	0	0	5

Component Detail All Funds
Department of Law

Component: Office of the Attorney General (2162)
RDU: Administration and Support (280)

Non-Formula Component

	FY2020 Actuals	FY2021 Conference Committee	FY2021 Authorized	FY2021 Management Plan	FY2022 Governor	FY2021 Management Plan vs FY2022 Governor	
71000 Personal Services	794.4	848.5	848.5	848.5	868.5	20.0	2.4%
72000 Travel	19.2	39.3	39.3	39.3	39.3	0.0	0.0%
73000 Services	126.4	58.8	58.8	58.8	38.8	-20.0	-34.0%
74000 Commodities	7.5	13.0	13.0	13.0	13.0	0.0	0.0%
75000 Capital Outlay	0.0	0.0	0.0	0.0	0.0	0.0	0.0%
77000 Grants, Benefits	0.0	0.0	0.0	0.0	0.0	0.0	0.0%
78000 Miscellaneous	0.0	0.0	0.0	0.0	0.0	0.0	0.0%
Totals	947.5	959.6	959.6	959.6	959.6	0.0	0.0%
Fund Sources:							
1001 CBR Fund (UGF)	0.0	126.1	126.1	126.1	0.0	-126.1	-100.0%
1004 Gen Fund (UGF)	416.7	378.4	378.4	378.4	504.5	126.1	33.3%
1007 I/A Rcpts (Other)	530.8	455.1	455.1	455.1	455.1	0.0	0.0%
Unrestricted General (UGF)	416.7	504.5	504.5	504.5	504.5	0.0	0.0%
Designated General (DGF)	0.0	0.0	0.0	0.0	0.0	0.0	0.0%
Other Funds	530.8	455.1	455.1	455.1	455.1	0.0	0.0%
Federal Funds	0.0	0.0	0.0	0.0	0.0	0.0	0.0%
Positions:							
Permanent Full Time	4	5	5	5	5	0	0.0%
Permanent Part Time	0	0	0	0	0	0	0.0%
Non Permanent	0	0	0	0	0	0	0.0%

Change Record Detail - Multiple Scenarios with Descriptions
Department of Law

Component: Office of the Attorney General (2162)

RDU: Administration and Support (280)

Scenario/Change Record Title	Trans Type	Totals	Personal Services	Travel	Services	Commodities	Capital Outlay	Grants, Benefits	Miscellaneous	Positions		NP
										PFT	PPT	
***** Changes From FY2021 Conference Committee To FY2021 Authorized *****												
Conference Committee												
	ConfCom	959.6	848.5	39.3	58.8	13.0	0.0	0.0	0.0	5	0	0
1001 CBR Fund		126.1										
1004 Gen Fund		378.4										
1007 I/A Rcpts		455.1										
Subtotal		959.6	848.5	39.3	58.8	13.0	0.0	0.0	0.0	5	0	0
***** Changes From FY2021 Management Plan To FY2022 Governor *****												
Fund Source Adjustment of CBRF to UGF												
	FndChg	0.0	0.0	0.0	0.0	0.0	0.0	0.0	0.0	0	0	0
1001 CBR Fund		-126.1										
1004 Gen Fund		126.1										
Transfer Authority from Services for Anticipated Personal Service Expenditures												
	LIT	0.0	20.0	0.0	-20.0	0.0	0.0	0.0	0.0	0	0	0
Transfer authority from the services line to the personal services line for anticipated personal services costs. The remaining services authority is anticipated to be sufficient to cover operating expenditures.												
Totals		959.6	868.5	39.3	38.8	13.0	0.0	0.0	0.0	5	0	0

Line Item Detail (1676)
Department of Law
Travel

Component: Office of the Attorney General (2162)

Line Number	Line Name		FY2020 Actuals	FY2021 Management Plan	FY2022 Governor
2000	Travel		19.2	39.3	39.3
Object Class	Servicing Agency	Explanation	FY2020 Actuals	FY2021 Management Plan	FY2022 Governor
2000 Travel Detail Totals			19.2	39.3	39.3
2000	In-State Employee Travel	Travel for attorneys to interview witnesses and attend court proceedings, as well as for necessary training for both attorneys and paraprofessionals. Includes travel for management purposes.	9.5	24.3	24.3
2002	Out of State Employee Travel	Travel costs and expenses for out-of-state travel for conferences, training, etc.	9.7	15.0	15.0

Line Item Detail (1676)
Department of Law
Services

Component: Office of the Attorney General (2162)

Line Number	Line Name		FY2020 Actuals	FY2021 Management Plan	FY2022 Governor
3000	Services		126.4	58.8	38.8
Object Class	Servicing Agency	Explanation	FY2020 Actuals	FY2021 Management Plan	FY2022 Governor
3000 Services Detail Totals			126.4	58.8	38.8
3000	Education Services	Conferences, training and memberships.	30.9	3.9	3.9
3003	Information Technology	Training, consulting and software licensing and maintenance. Annual maintenance fee for mission-critical information management systems.	0.1	0.1	0.1
3004	Telecommunications	Local telephone service, long distance charges and cellular phone services paid to third-party telephone utilities.	10.8	1.8	1.8
3005	Health Services	Costs associated with health and safety services.	0.0	0.3	0.3
3006	Delivery Services	Freight, courier, postage, and transportation of trial exhibit materials.	0.1	0.1	0.1
3007	Advertising and Promotions	Publication of legal notices.	2.5	0.5	0.5
3009	Structure/Infrastructure/Land	Rentals/leases - records and evidence storage.	0.1	0.1	0.1
3011	Other Services	Cost transfers and miscellaneous items within the services line (commissions, etc.).	0.2	0.2	0.2
3017	Inter-Agency Information Technology Non-Telecommunications	Admin - Department-wide RSA Administration, Office of Information Technology computer services.	0.0	14.9	4.9
3017	Inter-Agency Information Technology Non-Telecommunications	Law - Administrative Services (2164) RSA Administration, Office of Information Technology computer services.	17.9	0.0	0.0

Line Item Detail (1676)
Department of Law
Services

Component: Office of the Attorney General (2162)

Object Class		Servicing Agency	Explanation	FY2020 Actuals	FY2021 Management Plan	FY2022 Governor
3000 Services Detail Totals				126.4	58.8	38.8
3018	Inter-Agency Information Technology Telecommunications	Admin - Department-wide	RSA Administration, Office of Information Technology telecommunications services.	0.9	0.9	0.9
3020	Inter-Agency Building Maintenance	Admin - Department-wide	RSA Administration, General Services maintenance work.	2.0	2.0	2.0
3022	Inter-Agency Human Resources		RSA Law, Human Resources position.	2.8	0.0	0.0
3022	Inter-Agency Human Resources	Law - Administrative Services (2164)	RSA Law, Human Resources position.	1.9	4.7	2.7
3023	Inter-Agency Building Leases		Leased office space managed by General Services.	43.4	0.0	0.0
3023	Inter-Agency Building Leases	Admin - Department-wide	Leased office space managed by General Services.	8.9	28.0	20.5
3026	Inter-Agency Insurance	Admin - Department-wide	RSA Administration, Risk Management.	0.2	0.1	0.1
3027	Inter-Agency Financial	Admin - Department-wide	RSA Administration, Finance Chargeback (IRIS).	3.7	1.2	0.7

Line Item Detail (1676)
Department of Law
Commodities

Component: Office of the Attorney General (2162)

Line Number	Line Name		FY2020 Actuals	FY2021 Management Plan	FY2022 Governor
4000	Commodities		7.5	13.0	13.0
Object Class	Servicing Agency	Explanation	FY2020 Actuals	FY2021 Management Plan	FY2022 Governor
4000 Commodities Detail Totals			7.5	13.0	13.0
4000	Business	Reference materials and subscriptions, including statutes, software applications, non-capital desktop refresh, and miscellaneous office supplies.	7.2	12.5	12.5
4002	Household/Institutional	Institutional supplies for cleaning and maintenance.	0.3	0.5	0.5

Revenue Detail (1681)
Department of Law

Component: Office of the Attorney General (2162)

Revenue Type (OMB Fund Code) Revenue Source	Component	Comment	FY2020 Actuals	FY2021 Management Plan	FY2022 Governor
5007 I/A Rcpts (1007 I/A Rcpts)			533.5	455.1	455.1
5301 Inter-Agency Receipts			35.4	0.0	0.0
5301 Inter-Agency Receipts	Law - Dep. Attny General's Office (2205)	RSA Law - Deputy Attorney General's Office - legal support services for the Civil Division. Program code: AG03501655.	498.1	455.1	455.1
6004 Gen Fund (1004 Gen Fund)			33.3	0.0	0.0
6011 General Fund Gnrl Gov - Chrgs for Svcs Misc Receipts			0.1	0.0	0.0
6047 General Fund - Miscellaneous			33.2	0.0	0.0

Inter-Agency Services (1682)
Department of Law

Component: Office of the Attorney General (2162)

				FY2020 Actuals	FY2021 Management Plan	FY2022 Governor
Component Totals				35.5	51.8	31.8
With Department of Administration				15.7	47.1	29.1
With Department of Law				19.8	4.7	2.7
Object Class	Servicing Agency	Explanation	FY2020 Actuals	FY2021 Management Plan	FY2022 Governor	
3017	Inter-Agency Information Technology Non-Telecommunications	Admin - Department-wide	RSA Administration, Office of Information Technology computer services.	0.0	14.9	4.9
3017	Inter-Agency Information Technology Non-Telecommunications	Law - Administrative Services (2164)	RSA Administration, Office of Information Technology computer services.	17.9	0.0	0.0
3018	Inter-Agency Information Technology Telecommunications	Admin - Department-wide	RSA Administration, Office of Information Technology telecommunications services.	0.9	0.9	0.9
3020	Inter-Agency Building Maintenance	Admin - Department-wide	RSA Administration, General Services maintenance work.	2.0	2.0	2.0
3022	Inter-Agency Human Resources	Law - Administrative Services (2164)	RSA Law, Human Resources position.	1.9	4.7	2.7
3023	Inter-Agency Building Leases	Admin - Department-wide	Leased office space managed by General Services.	8.9	28.0	20.5
3026	Inter-Agency Insurance	Admin - Department-wide	RSA Administration, Risk Management.	0.2	0.1	0.1
3027	Inter-Agency Financial	Admin - Department-wide	RSA Administration, Finance Chargeback (IRIS).	3.7	1.2	0.7

Personal Services Expenditure Detail
Department of Law

Scenario: FY2022 Governor (17280)
Component: Office of the Attorney General (2162)
RDU: Administration and Support (280)

PCN	Job Class Title	Time Status	Retire Code	Barg Unit	Location	Salary Sched	Range / Step	Comp Months	Split / Count	Annual Salaries	COLA	Premium Pay	Annual Benefits	Total Costs	UGF Amount
03-0001	Commissioner	FT	A	XE	Anchorage	N00	0	12.0		141,156	0	0	66,905	208,061	208,061
03-0012	Executive Secretary III	FT	A	XE	Anchorage	N00	16F / J	12.0		63,007	0	0	40,209	103,216	103,216
03-0199	Deputy Attorney General	FT	A	XE	Anchorage	N00	28U	12.0		186,810	0	0	79,803	266,613	0
03-0310	Sp Asst Commrii	FT	A	XE	Anchorage	N00	23J / K	12.0		105,976	0	0	54,888	160,864	112,605
03-0371	Sp Asst Commrii	FT	A	XE	Anchorage	N00	23B / C	12.0		87,399	0	0	48,542	135,941	0
Total													Total Salary Costs:	584,348	
Positions													Total COLA:	0	
Full Time Positions:													Total Premium Pay:	0	
Part Time Positions:													Total Benefits:	290,347	
Non Permanent Positions:															
Positions in Component:													Total Pre-Vacancy:	874,695	
													Minus Vacancy Adjustment of 0.71%:	(6,195)	
													Total Post-Vacancy:	868,500	
													Plus Lump Sum Premium Pay:	0	
													Personal Services Line 100:	868,500	

PCN Funding Sources:	Pre-Vacancy	Post-Vacancy	Percent
1004 General Fund Receipts	423,882	420,880	48.46%
1007 Interagency Receipts	450,813	447,620	51.54%
Total PCN Funding:	874,695	868,500	100.00%

Note: If a position is split, an asterisk (*) will appear in the Split/Count column. If the split position is also counted in the component, two asterisks (**) will appear in this column. [No valid job title] appearing in the Job Class Title indicates that the PCN has an invalid class code or invalid range for the class code effective date of this scenario.

Administration and Support

Office of the Attorney General

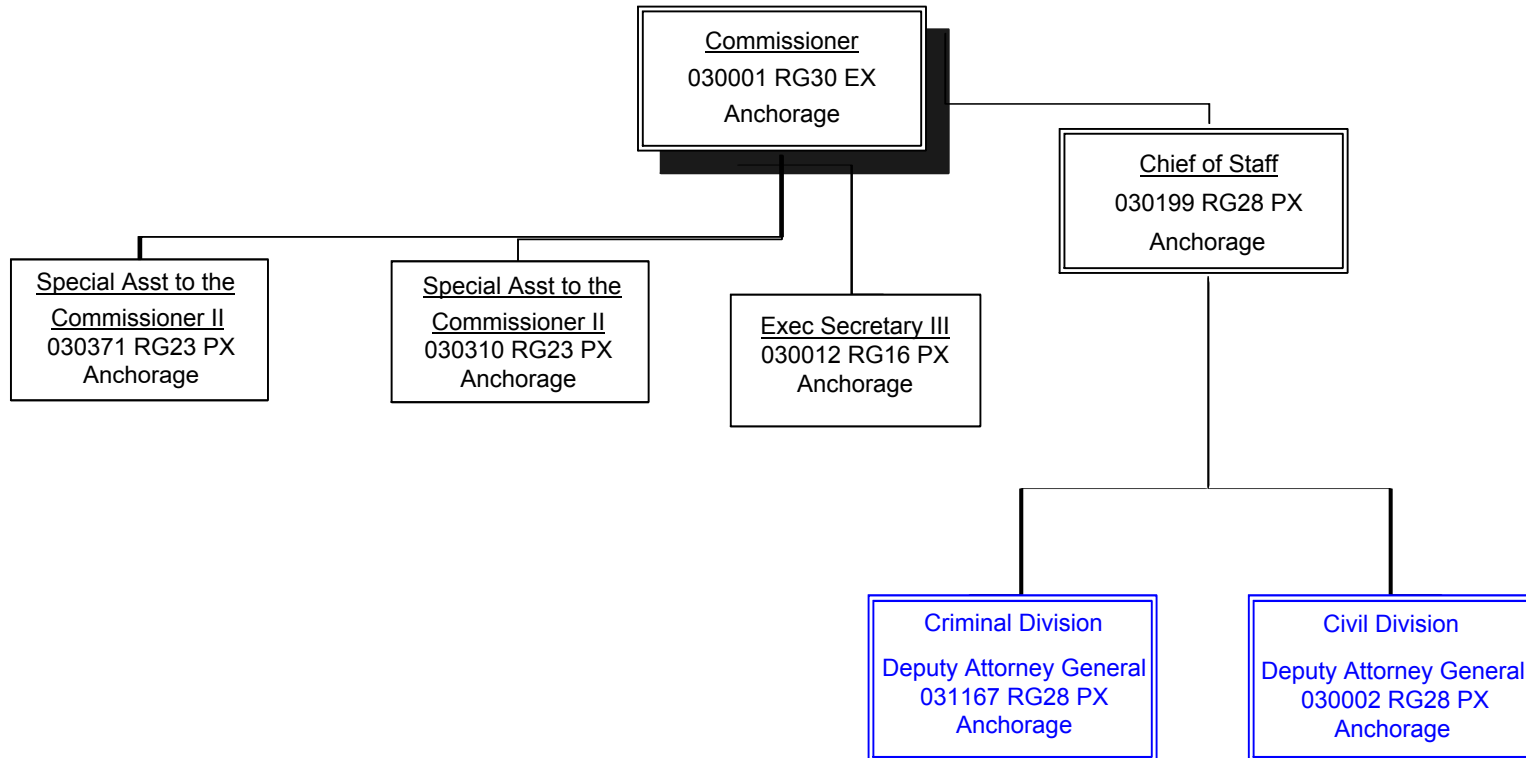

Note: Positions outlined in blue indicate that the PCNs are counted elsewhere but shown here to indicate organizational hierarchy.

Position Count: 5