

State of Alaska FY2022 Governor's Operating Budget

Department of Public Safety Special Projects Component Budget Summary

Component: Special Projects

Contribution to Department's Mission

Preserve public peace, protect life, property, and resources.

Core Services

- Provide law enforcement within the Chugach and Tongass National Forests through U.S. Forest Service contracts.
- Participate in a taskforce environment to investigate smuggling and distribution of controlled substances with Drug Enforcement Administration (DEA) support.
- Deter crime by depriving criminals of the profits and proceeds of their illegal activities through narcotics suppression federal forfeitures.
- Support law enforcement officer overtime with DEA and Organized Crime Drug Enforcement Task Force (OCDETF) funding.
- Promote domestic violence and sexual assault investigation training statewide, using funds from the Council on Domestic Violence and Sexual Assault.

Major Component Accomplishments in 2020

Working with the U.S. Forest Service, the department provided cooperative effort between the enforcement agencies to enhance State and local law enforcement activities on federal lands in the Chugach and Tongass National Forests.

The state's asset seizures from criminal drug investigations go directly into the state's General Fund. The Federal Narcotics Suppression (forfeitures) Program provides the department and other law enforcement agencies with some limited funding for equipment for transportation, officer protection, training, communications, and surveillance equipment.

The Drug Enforcement Administration (DEA), Federal Bureau of Investigation (FBI), Homeland Security Investigations (HSI) and Organized Crime Drug Enforcement Task Force (OCDETF) overtime funds allow for investigators assigned to specialized task force positions to focus on the pursuit of violent drug offenders and individuals involved in organized crime.

The High Intensity Drug Trafficking Area (HIDTA) program provides funding for trooper overtime funds and allows for the acquisition of greatly needed equipment, training, and the ability to travel in and out of state to conduct high level drug trafficking and distribution cases.

In FY2020, AST's Domestic Violence and Sexual Assault (DVSA) statewide program coordinated or participated in 34 training sessions and trained a total of 716 multidisciplinary professionals. Of these, 340 were law enforcement officers and an additional 97 were correctional officers. The remainder were members of other professions including prosecutors, forensic medical providers, victim advocates and tribal representatives. In FY2020, the DVSA program focused on providing specialized training on domestic violence and sex crimes investigations. In addition to training, the program partnered with the Language Interpreter Center to translate the mandatory victims' rights booklet (DVSA) in to 9 languages. This booklet was also revised and updated with new English versions being distributed to all AST detachments and posts as well as all municipal police agencies. After significant analysis and discussion, DPS finalized OPM Chapter 212 which is specific to domestic violence response and investigations. This was approved and released at the beginning of FY20 in August of 2019.

AST in conjunction with CDVSA provided one three-day sexual assault response team (SART) training in Fairbanks to multidisciplinary team members including law enforcement, medical providers, prosecutors and victim advocates. Furthermore, AST in partnership with ANDVSA and the Language Interpreter Center provided training and technical assistance to the Fairbanks SART team.

AST in partnership with Department of Law and ANDVSA, sponsored an advance strangulation response and investigation course. The DVSA program continues to support the VPO training academy held in Bethel, Alaska at the

YUUT. This course covers both domestic violence and sexual assault investigations. In addition to the training mentioned above the DVSA program provided training to the Department of Corrections Academy. In FY2020, the DVSA section was invited to speak to the OVW tribal grantees annual meeting in Alaska and the ANDVSA Annual Legal Advocacy Training.

Key Component Challenges

The capabilities and efficiency of personnel within the criminal justice system in Alaska, both within the Department of Public Safety (DPS) and other agencies need to be increased in order to obtain the best use of available personnel. Ongoing training is the key to continued improved law enforcement response and performance. Staffing levels for both DPS and municipal law enforcement agencies make it challenging to provide training opportunities while maintaining vital coverage for emergency response. To maximize training efforts and grant funds, AST collaborates with CDVSA, DOL and ANDVSA. Without these partnerships, less training opportunities would be available for law enforcement statewide, including both AST and municipal agencies as well as VPSOs and VPO/TPOs. In addition, due to the pandemic, the majority of training sessions in the last quarter of SFY20 were postponed or cancelled. The training unit utilized this time to develop virtual training materials and finalize several critical documents such as the strangulation documentation form, the anonymous reporting conversion form and the forms that accompany the sexual assault evidence collection kits.

Importation of controlled substances to meet high demand remains one of the significant problems facing society. The introduction of fentanyl - an adulterating additive to many drugs such as heroin, methamphetamine, cocaine, and counterfeit pills - has made controlled substances more lethal not only for the consumer but also for those who inadvertently come into contact with these substances. Alaska lacks sufficient resources to provide effective treatment for offenders to prevent recidivism, which only increases the challenges faced by law enforcement agencies.

Importation of alcohol and drugs into rural Alaskan communities by organizations lured to Alaska by the high profit potential continues to be a significant challenge. Even though several federal agencies offer task force programs to enhance collaborative law enforcement efforts, many smaller communities cannot spare or do not have any personnel or resources to combat the problem. This in turn makes it difficult for AST to find law enforcement partners to conduct effective drug and alcohol investigations in many communities in Alaska. Consequently, AST concentrates its limited resources in "hub" communities in order to maximize effectiveness.

Significant Changes in Results to be Delivered in FY2022

Alaska State Troopers (AST) will continue its active support to end the epidemic of sexual assault and domestic violence by providing enhanced training to law enforcement and first responders to increase understanding and recognition of these crimes in order to improve services to victims in Alaska and to promote the reporting of these crimes. Much of this training will be provided in a virtual format, due to the pandemic. AST will continue partnerships with CDVSA, DOL and ANDVSA and host a series of virtual training sessions (Summer, Fall and Winter). The DVSA training unit will continue to provide in person instruction at the DPS academy in Sitka and the VPO academy in Bethel. AST will evaluate other remote/virtual training opportunities that are available on a national level specific to strangulation and forensic interviewing of adults and children. AST will "roll out" the new strangulation documentation form and anonymous reporting conversion forms to the field. Furthermore, the DVSA program will continue to analyze and review department policies, procedures and practices to ensure that every effort is made to conform to state laws and national best practices. The DVSA program will work in SFY 21 to bring forward recommended edits to the OPM chapters specific to sexual assault and sexual abuse of minor cases.

AST will continue to establish and maintain outstanding collaborative relationships with all federal/state/local law enforcement agencies involved in the investigation of narcotics trafficking and distribution statewide. Additionally, AST will continue to seek out non-law enforcement and non-governmental organizations to partner with to reduce the effects of drugs and alcohol on Alaska communities.

AST, in partnership with Alaska HIDTA participants, is dedicated to the investigation and interdiction of illegal drugs within Alaska as well as tracing illicit shipments back to source locations. In 2020, there are 23 agencies

participating in the Alaska HIDTA; 11 local, four state, and eight Federal. AST will seek additional partnerships with municipal law enforcement agencies to combat narcotics trafficking through Alaska HIDTA.

Statutory and Regulatory Authority

DPS-Powers and duties of department (AS 44.41.020)
State Troopers (AS 18.65.010 - AS 18.65.110)
Police Protection (AS 18.65.010 - AS 18.65.790)
Law enforcement duties (AS 18.65.010 - AS 18.65.086)
Controlled Substances (AS 11.71.010 - AS 11.71.900)
Village Public Safety Officer Definition (AS 01.10.060(c)(7)(C))
VPSO Program (AS 18.65.670)
Department to assist other agencies (AS 18.65.090)
Document and disseminate information regarding homicides (AS 44.41.040)
Document and investigate missing persons (AS 18.65.610)
DUI Forfeiture Requirements (AS 28.35.036-.037)
DPS DNA collection and registration requirements (AS 44.41.035)
Duty of Law Enforcement to Provide VCCB information (AS 18.67.175)

Contact Information
<p>Contact: Elizabeth Dunayski, Administrative Services Director Phone: (907) 465-5501 E-mail: elizabeth.dunayski@alaska.gov</p>

Special Projects Personal Services Information					
Authorized Positions			Personal Services Costs		
	<u>FY2021</u> <u>Management</u> <u>Plan</u>	<u>FY2022</u> <u>Governor</u>			
Full-time	5	5	Annual Salaries		666,365
Part-time	0	0	COLA		7,514
Nonpermanent	3	3	Premium Pay		756
			Annual Benefits		312,274
			<i>Less 0.03% Vacancy Factor</i>		(312)
			Lump Sum Premium Pay		0
Totals	8	8	Total Personal Services		986,597

Position Classification Summary					
Job Class Title	Anchorage	Fairbanks	Juneau	Others	Total
Administrative Officer II	1	0	0	0	1
AK Hidta Director	1	0	0	0	1
Corporal DPS	1	0	0	0	1
Crim Int Any II	1	0	0	0	1
Crim Int Anyiii	1	0	0	0	1
Program Coordinator II	2	0	0	0	2
Project Assistant	1	0	0	0	1
Totals	8	0	0	0	8

Component Detail All Funds
Department of Public Safety

Component: Special Projects (1001)
RDU: Alaska State Troopers (160)

Non-Formula Component

	FY2020 Actuals	FY2021 Conference Committee	FY2021 Authorized	FY2021 Management Plan	FY2022 Governor	FY2021 Management Plan vs FY2022 Governor	
71000 Personal Services	17,714.4	935.1	935.1	1,002.1	986.6	-15.5	-1.5%
72000 Travel	159.2	845.8	845.8	845.8	826.9	-18.9	-2.2%
73000 Services	1,340.5	4,122.7	4,122.7	4,055.7	4,055.7	0.0	0.0%
74000 Commodities	383.4	766.8	766.8	766.8	766.8	0.0	0.0%
75000 Capital Outlay	1,258.1	828.5	828.5	828.5	828.5	0.0	0.0%
77000 Grants, Benefits	228.7	0.0	0.0	0.0	0.0	0.0	0.0%
78000 Miscellaneous	0.0	0.0	0.0	0.0	0.0	0.0	0.0%
Totals	21,084.3	7,498.9	7,498.9	7,498.9	7,464.5	-34.4	-0.5%
Fund Sources:							
1001 CBR Fund (UGF)	0.0	26.5	26.5	26.5	0.0	-26.5	-100.0%
1002 Fed Rcpts (Fed)	4,124.1	7,039.7	7,039.7	7,039.7	7,047.5	7.8	0.1%
1004 Gen Fund (UGF)	70.6	79.4	79.4	79.4	106.2	26.8	33.8%
1007 I/A Rcpts (Other)	16,889.6	343.6	343.6	343.6	301.1	-42.5	-12.4%
1061 CIP Rcpts (Other)	0.0	9.7	9.7	9.7	9.7	0.0	0.0%
Unrestricted General (UGF)	70.6	105.9	105.9	105.9	106.2	0.3	0.3%
Designated General (DGF)	0.0	0.0	0.0	0.0	0.0	0.0	0.0%
Other Funds	16,889.6	353.3	353.3	353.3	310.8	-42.5	-12.0%
Federal Funds	4,124.1	7,039.7	7,039.7	7,039.7	7,047.5	7.8	0.1%
Positions:							
Permanent Full Time	4	4	4	5	5	0	0.0%
Permanent Part Time	0	0	0	0	0	0	0.0%
Non Permanent	3	3	3	3	3	0	0.0%

Change Record Detail - Multiple Scenarios with Descriptions
Department of Public Safety

Component: Special Projects (1001)
RDU: Alaska State Troopers (160)

Scenario/Change Record Title	Trans Type	Totals	Personal Services	Travel	Services	Commodities	Capital Outlay	Grants, Benefits	Miscellaneous	Positions		NP
										PFT	PPT	
***** Changes From FY2021 Conference Committee To FY2021 Authorized *****												
Conference Committee												
	ConfCom	7,498.9	935.1	845.8	4,122.7	766.8	828.5	0.0	0.0	4	0	3
1001 CBR Fund		26.5										
1002 Fed Rcpts		7,039.7										
1004 Gen Fund		79.4										
1007 I/A Rcpts		343.6										
1061 CIP Rcpts		9.7										
Subtotal		7,498.9	935.1	845.8	4,122.7	766.8	828.5	0.0	0.0	4	0	3
***** Changes From FY2021 Authorized To FY2021 Management Plan *****												
Align Authority for Personal Services												
	LIT	0.0	67.0	0.0	-67.0	0.0	0.0	0.0	0.0	0	0	0
Transfer from services to personal services to align authority to reflect personnel changes. The remaining services authority is sufficient to cover anticipated expenditures.												
Add Program Coordinator II to Support the Federal High Intensity Drug Trafficking Area (HIDTA) Program												
	PosAdj	0.0	0.0	0.0	0.0	0.0	0.0	0.0	0.0	1	0	0
Add Program Coordinator II position dedicated to the federal High Intensity Drug Trafficking Area (HIDTA) program. This position will serve as the central point of contact for coordinating and managing law enforcement officer training opportunities for HIDTA initiatives. HIDTA program policies require a training coordinator. This position is contingent upon continuation of Alaska's HIDTA designation and receipt of associated federal funding which the department anticipates will continue indefinitely.												
Subtotal		7,498.9	1,002.1	845.8	4,055.7	766.8	828.5	0.0	0.0	5	0	3
***** Changes From FY2021 Management Plan To FY2022 Governor *****												
FY2022 Salary Adjustments												
	SalAdj	9.2	9.2	0.0	0.0	0.0	0.0	0.0	0.0	0	0	0
1002 Fed Rcpts		7.8										
1004 Gen Fund		0.3										
1007 I/A Rcpts		1.1										
FY2022 3% COLA for Public Safety Employees Association (AA/AP): \$4.8												
FY2022 1% COLA for ASEA/General Government (GG/GP/GY/GZ): \$4.4												
Reduce Authority to Align with Anticipated Revenue												
	Dec	-43.6	-24.7	-18.9	0.0	0.0	0.0	0.0	0.0	0	0	0

Change Record Detail - Multiple Scenarios with Descriptions
Department of Public Safety

Component: Special Projects (1001)
RDU: Alaska State Troopers (160)

Scenario/Change Record Title	Trans Type	Totals	Personal Services	Travel	Services	Commodities	Capital Outlay	Grants, Benefits	Miscellaneous	Positions		NP
										PFT	PPT	
1007 I/A Rcpts		-43.6										
Reduce interagency receipt authority based on anticipated revenue.												
Fund Source Adjustment of CBRF to UGF												
	FndChg	0.0	0.0	0.0	0.0	0.0	0.0	0.0	0.0	0	0	0
1001 CBR Fund		-26.5										
1004 Gen Fund		26.5										
Replace Constitutional Budget Reserve Fund (CBRF) used as a one-time funding mechanism in FY2021.												
Totals		7,464.5	986.6	826.9	4,055.7	766.8	828.5	0.0	0.0	5	0	3

Line Item Detail (1676)
Department of Public Safety
Travel

Component: Special Projects (1001)

Line Number	Line Name		FY2020 Actuals	FY2021 Management Plan	FY2022 Governor
2000	Travel		159.2	845.8	826.9
Object Class	Servicing Agency	Explanation	FY2020 Actuals	FY2021 Management Plan	FY2022 Governor
2000 Travel Detail Totals			159.2	845.8	826.9
2000	In-State Employee Travel	Instate Travel costs for state troopers to enforce activities funded by federal grants and travel for the training funded by the Violence Against Women Act (VAWA) (VAWA Coordinator and state troopers).	62.8	112.0	112.0
2000	In-State Employee Travel	Travel for HIDTA grant activities.	0.0	423.8	423.8
2001	In-State Non-Employee Travel	Instate Travel costs for non-employee law enforcement individuals related to enforce activities funded by federal grants and travel for the training funded by the Violence Against Women Act (VAWA).	45.2	15.0	15.0
2002	Out of State Employee Travel	Out of State Travel for staff to attend meetings and conferences related to federal grant management and the VAWA program. Includes travel costs for other police officers attending training provided by DPS through federal programs.	47.3	230.0	211.1
2002	Out of State Employee Travel	Out of State Travel for HIDTA Grant activities.	0.0	60.0	60.0
2003	Out of State Non-Employee Travel	Out of State Travel for non-employee staff to attend meetings and conferences related to federal grant management and the VAWA program. Includes travel costs for other police officers attending	3.9	5.0	5.0

Line Item Detail (1676)
Department of Public Safety
Travel

Component: Special Projects (1001)

Object Class	Servicing Agency	Explanation	FY2020 Actuals	FY2021 Management Plan	FY2022 Governor
2000 Travel Detail Totals			159.2	845.8	826.9
training provided by DPS through federal programs.					

Line Item Detail (1676)
Department of Public Safety
Services

Component: Special Projects (1001)

Line Number	Line Name		FY2020 Actuals	FY2021 Management Plan	FY2022 Governor
3000	Services		1,340.5	4,055.7	4,055.7
Object Class	Servicing Agency	Explanation	FY2020 Actuals	FY2021 Management Plan	FY2022 Governor
3000 Services Detail Totals			1,340.5	4,055.7	4,055.7
3000	Education Services	Training for law enforcement officers throughout Alaska funded by Violence Against Women Act (VAWA) funds. Topics include Sexual Assault Response Team (SART) training, domestic violence, law enforcement officers as expert witnesses, dispatcher training, advanced forensic investigator, and multidisciplinary conference. Also, includes conference registration and training for law enforcement officers funded from federal funds.	26.2	40.0	40.0
3001	Financial Services	Management Consulting for SAKI Grant.	0.0	426.5	426.5
3001	Financial Services	One-time COVID-19 grant expenses.	71.2	0.0	0.0
3002	Legal and Judicial Services	Legal services.	21.7	0.0	0.0
3003	Information Technology	Consulting services and software licenses for technology projects. Microsoft Exchange & ARMS Maintenance Agreement.	38.1	93.2	93.2
3004	Telecommunications	Long distance, local, cellular, and basic telephone equipment purchases.	4.0	7.0	7.0
3004	Telecommunications	One-time COVID-19 grant expenses.	22.6	0.0	0.0
3005	Health Services	One-time COVID-19 grant expenses.	30.2	0.0	0.0
3006	Delivery Services	Miscellaneous freight and delivery of	1.0	0.0	0.0
FY2022 Governor Department of Public Safety			Released December 15, 2020 Page 11		

Line Item Detail (1676)
Department of Public Safety
Services

Component: Special Projects (1001)

Object Class		Servicing Agency	Explanation	FY2020 Actuals	FY2021 Management Plan	FY2022 Governor
			3000 Services Detail Totals	1,340.5	4,055.7	4,055.7
			goods.			
3009	Structure/Infrastructure/Land		Space expenses for evidence storage and room rentals (training).	159.0	200.0	195.9
3009	Structure/Infrastructure/Land		One-time COVID-19 grant expenses.	231.2	0.0	0.0
3010	Equipment/Machinery		Repair and maintenance of communication equipment, electronics, and law enforcement equipment funded from federal receipts.	2.0	1.0	1.0
3010	Equipment/Machinery		One-time COVID-19 grant expenses.	76.6	0.0	0.0
3011	Other Services		Printing, copier services, honorariums for presenters/trainers. Law enforcement services. Commissioned sales for the State Travel Office.	187.6	200.0	200.0
3011	Other Services		Contractual services in support of the HIDTA Grant activities. Includes management consulting and professional services, training, software licenses, and undercover investigations.	0.0	2,825.0	2,825.0
3017	Inter-Agency Information Technology Non-Telecommunications	Admin - Department-wide	Non-telecommunication (mainframe, computer support, sponsored agencies, and VPN).	17.8	20.0	20.0
3017	Inter-Agency Information Technology Non-Telecommunications	PubSaf - Information Systems (3199)	Non-telecommunications (LAN/WAN & APSIN).	1.2	5.0	5.0
3018	Inter-Agency Information Technology Telecommunications	Admin - Department-wide	Telecommunication support services (EPR & Basic Phones).	1.1	3.0	3.0
3020	Inter-Agency Building Maintenance	Trans - Department-wide	Building and yard maintenance.	5.4	6.0	6.5
3021	Inter-Agency Mail	Admin - Department-wide	Central mail service.	0.1	1.0	1.0
3021	Inter-Agency Mail	PubSaf - AST Detachments (2325)	DPS HQ mailroom services.	0.0	1.0	1.0
3022	Inter-Agency Human Resources	Admin - Department-wide	HR personnel support.	3.1	1.0	3.1

Line Item Detail (1676)
Department of Public Safety
Services

Component: Special Projects (1001)

Object Class		Servicing Agency	Explanation	FY2020 Actuals	FY2021 Management Plan	FY2022 Governor
3000 Services Detail Totals				1,340.5	4,055.7	4,055.7
3024	Inter-Agency Legal	Law - Department-wide	HIDTA prosecution initiative.	213.0	215.0	215.0
3024	Inter-Agency Legal	Law - Department-wide	Legal Services.	1.2	1.0	1.5
3026	Inter-Agency Insurance	Admin - Department-wide	Risk Management property and overhead insurance.	0.4	1.0	1.5
3027	Inter-Agency Financial	Admin - Department-wide	HRM/ ALDER/ IRIS financial support.	0.5	1.0	1.0
3037	State Equipment Fleet	Trans - Department-wide	State Equipment Fleet	0.0	1.0	1.5
3038	Inter-Agency Management/Consulting	Admin - Department-wide	Adjustments correcting charges to RSA.	0.0	0.0	0.0
3038	Inter-Agency Management/Consulting	PubSaf - Administrative Services (525)	DPS Admin Services cost allocation.	3.3	3.5	3.5
3038	Inter-Agency Management/Consulting	PubSaf - AST Detachments (2325)	DPS Office of Professional Services cost allocation.	0.0	1.0	1.0
3038	Inter-Agency Management/Consulting	PubSaf - Commissioner's Office (523)	DPS Commissioner's Office cost allocation.	2.1	2.5	2.5
7003	Sub-Recipient Pass-Through Grants		Pass-through grants awarded by the National Sexual Assault Kit Initiative (SAKI)	219.9	0.0	0.0

Line Item Detail (1676)
Department of Public Safety
Commodities

Component: Special Projects (1001)

Line Number	Line Name		FY2020 Actuals	FY2021 Management Plan	FY2022 Governor
4000	Commodities		383.4	766.8	766.8
Object Class	Servicing Agency	Explanation	FY2020 Actuals	FY2021 Management Plan	FY2022 Governor
4000 Commodities Detail Totals			383.4	766.8	766.8
4000	Business	Business, office, photographic, computer supplies and educational subscriptions.	149.5	225.0	225.0
4000	Business	Business supplies in support of the HIDTA Grant activities. Includes office supplies, safety and investigative supplies.	0.0	93.0	93.0
4002	Household/Institutional	Clothing, uniforms, cleaning, food and non-food supplies.	16.1	25.0	25.0
4003	Scientific and Medical	Laboratory supplies.	50.7	75.8	75.8
4004	Safety	Business supplies in support of the HIDTA Grant activities. Includes office supplies, safety and investigative supplies.	77.7	0.0	0.0
4019	Small Tools/Minor Equipment	Parts and supplies used to repair and maintain equipment.	0.0	345.0	345.0
4020	Equipment Fuel	Equipment fuel.	0.0	3.0	3.0
4021	Commodity Management Allocation	COVID-19 adjustment	89.4	0.0	0.0

Line Item Detail (1676)
Department of Public Safety
Capital Outlay

Component: Special Projects (1001)

Line Number	Line Name		FY2020 Actuals	FY2021 Management Plan	FY2022 Governor
5000	Capital Outlay		1,258.1	828.5	828.5
Object Class	Servicing Agency	Explanation	FY2020 Actuals	FY2021 Management Plan	FY2022 Governor
5000 Capital Outlay Detail Totals			1,258.1	828.5	828.5
5002	Structures and Infrastructure	Miscoded commodities.	16.0	0.0	0.0
5004	Equipment	Equipment, electronics, communications, surveillance, and other equipment with cost of \$5,000 or greater and life greater than one year.	1,242.1	210.5	210.5
5004	Equipment	Equipment in support of the HIDTA Grant activities. Includes office equipment, computers, desks, office furniture, printer, phones and LAN infrastructures to establish the office, as well as investigative equipment for investigations.	0.0	618.0	618.0

Line Item Detail (1676)
Department of Public Safety
Grants, Benefits

Component: Special Projects (1001)

Line Number	Line Name		FY2020 Actuals	FY2021 Management Plan	FY2022 Governor
7000	Grants, Benefits		228.7	0.0	0.0
Object Class	Servicing Agency	Explanation	FY2020 Actuals	FY2021 Management Plan	FY2022 Governor
7000 Grants, Benefits Detail Totals			228.7	0.0	0.0
7003	Sub-Recipient Pass-Through Grants	Project Safe Neighborhoods sub-grant with the Municipality of Anchorage.	80.9	0.0	0.0
7003	Sub-Recipient Pass-Through Grants	Pass-through grants awarded by the National Sexual Assault Kit Initiative (SAKI)	147.8	0.0	0.0

Revenue Detail (1681)
Department of Public Safety

Component: Special Projects (1001)

Revenue Type (OMB Fund Code) Revenue Source	Component	Comment	FY2020 Actuals	FY2021 Management Plan	FY2022 Governor
5002 Fed Rcpts (1002 Fed Rcpts)			4,124.1	7,039.7	7,047.5
5011 Federal Public Prctn - Federal Emergency Management Agency		Federal Receipt Authority for Special Project Federal Grants, such as: USFS, DEA OT Reimbursement, DOJ Forfeitures & Treasury Forfeitures, COPS, RSAT, SLIGP, USMS, ICAC, BJA Drug Enf.	15.5	15.0	15.0
5014 Federal Public Protection - Miscellaneous Grants		Federal Receipt Authority for Special Project Federal Grants, such as: USFS, DEA OT Reimbursement, DOJ Forfeitures & Treasury Forfeitures, COPS, RSAT, SLIGP, USMS, ICAC, BJA Drug Enf.	1,709.8	2,024.7	2,032.5
5014 Federal Public Protection - Miscellaneous Grants		Federal Receipt Authority for the High Intensity Drug Trafficking Area (HIDTA)	2,398.8	5,000.0	5,000.0
5007 I/A Rcpts (1007 I/A Rcpts)			16,889.6	343.6	301.1
5301 Inter-Agency Receipts		Department of Health and Social Services COVID-19	16,695.3	0.0	0.0
5301 Inter-Agency Receipts	PubSaf - Special Projects (1001)	Violence Against Women Act (VAWA) federal funds for the training of law enforcement officers, VAWA travel, and misc. VAWA expenses.	194.3	343.6	301.1
5061 CIP Rcpts (1061 CIP Rcpts)			0.0	9.7	9.7
5351 Capital Improvement Project Inter-Agency		CIP Receipt authorization for unanticipated CIP Reimbursable Service Agreements.	0.0	9.7	9.7

Inter-Agency Services (1682)
Department of Public Safety

Component: Special Projects (1001)

				FY2020 Actuals	FY2021 Management Plan	FY2022 Governor
Component Totals				249.2	263.0	267.1
With Department of Administration				23.0	27.0	29.6
With Department of Public Safety				6.6	13.0	13.0
With Department of Transportation/Public Facilities				5.4	7.0	8.0
With Department of Law				214.2	216.0	216.5
Object Class	Servicing Agency	Explanation		FY2020 Actuals	FY2021 Management Plan	FY2022 Governor
3017	Inter-Agency Information Technology Non-Telecommunications	Admin - Department-wide Non-telecommunication (mainframe, computer support, sponsored agencies, and VPN).		17.8	20.0	20.0
3017	Inter-Agency Information Technology Non-Telecommunications	PubSaf - Information Systems (3199) Non-telecommunications (LAN/WAN & APSIN).		1.2	5.0	5.0
3018	Inter-Agency Information Technology Telecommunications	Admin - Department-wide Telecommunication support services (EPR & Basic Phones).		1.1	3.0	3.0
3020	Inter-Agency Building Maintenance	Trans - Department-wide Building and yard maintenance.		5.4	6.0	6.5
3021	Inter-Agency Mail	Admin - Department-wide Central mail service.		0.1	1.0	1.0
3021	Inter-Agency Mail	PubSaf - AST Detachments (2325) DPS HQ mailroom services.		0.0	1.0	1.0
3022	Inter-Agency Human Resources	Admin - Department-wide HR personnel support.		3.1	1.0	3.1
3024	Inter-Agency Legal	Law - Department-wide HIDTA prosecution initiative.		213.0	215.0	215.0
3024	Inter-Agency Legal	Law - Department-wide Legal Services.		1.2	1.0	1.5
3026	Inter-Agency Insurance	Admin - Department-wide Risk Management property and overhead insurance.		0.4	1.0	1.5
3027	Inter-Agency Financial	Admin - Department-wide HRM/ ALDER/ IRIS financial support.		0.5	1.0	1.0
3037	State Equipment Fleet	Trans - Department-wide State Equipment Fleet		0.0	1.0	1.5
3038	Inter-Agency Management/Consulting	PubSaf - Administrative Services (525) DPS Admin Services cost allocation.		3.3	3.5	3.5
3038	Inter-Agency Management/Consulting	PubSaf - AST Detachments (2325) DPS Office of Professional Services cost allocation.		0.0	1.0	1.0
3038	Inter-Agency	PubSaf - Commissioner's Office (523) DPS Commissioner's Office cost		2.1	2.5	2.5

Inter-Agency Services (1682)
Department of Public Safety

Component: Special Projects (1001)

Object Class	Servicing Agency	Explanation	FY2020 Actuals	FY2021 Management Plan	FY2022 Governor
Management/Consulting		allocation.			

Personal Services Expenditure Detail
Department of Public Safety

Scenario: FY2022 Governor (17280)
Component: Special Projects (1001)
RDU: Alaska State Troopers (160)

PCN	Job Class Title	Time Status	Retire Code	Barg Unit	Location	Salary Sched	Range / Step	Comp Months	Split / Count	Annual Salaries	COLA	Premium Pay	Annual Benefits	Total Costs	UGF Amount
12-?147	Program Coordinator II	FT	A	GP	Anchorage	100	20A	12.0		68,855	947	0	44,666	114,468	0
12-1887	Program Coordinator II	FT	A	GP	Anchorage	100	20G	12.0		84,221	1,159	0	50,441	135,821	33,955
12-2066	Crim Int Anyiii	FT	A	SS	Anchorage	100	19E / F	12.0		79,807	0	0	48,822	128,629	0
12-2067	Crim Int Any II	FT	A	GP	Anchorage	100	17C / D	12.0		61,653	848	0	41,960	104,461	0
12-2084	Administrative Officer II	FT	A	GP	Anchorage	100	19C / D	12.0		69,622	958	0	44,954	115,534	0
12-N15009	Project Assistant	NP	N	GP	Anchorage	100	16A	12.0		52,221	604	0	26,926	79,751	0
12-N18007	Corporal DPS	NP	N	AA	Anchorage	100	78B	12.0		87,464	2,998	756	11,707	102,925	0
12-T011	AK Hidta Director	NP	N	XE	Anchorage	N00	24A	12.0		162,522	0	0	42,798	205,320	0

	Total Positions	New	Deleted
Full Time Positions:	5	0	0
Part Time Positions:	0	0	0
Non Permanent Positions:	3	0	0
Positions in Component:	8	0	0

Total Component Months: 96.0

Total Salary Costs:	666,365
Total COLA:	7,514
Total Premium Pay:	756
Total Benefits:	312,274
Total Pre-Vacancy:	986,909
Minus Vacancy Adjustment of 0.03%:	(312)
Total Post-Vacancy:	986,597
Plus Lump Sum Premium Pay:	0
Personal Services Line 100:	986,597

PCN Funding Sources:	Pre-Vacancy	Post-Vacancy	Percent
1002 Federal Receipts	811,213	810,956	82.20%
1004 General Fund Receipts	33,955	33,945	3.44%
1007 Interagency Receipts	141,741	141,696	14.36%
Total PCN Funding:	986,909	986,597	100.00%

Note: If a position is split, an asterisk (*) will appear in the Split/Count column. If the split position is also counted in the component, two asterisks (**) will appear in this column. [No valid job title] appearing in the Job Class Title indicates that the PCN has an invalid class code or invalid range for the class code effective date of this scenario.

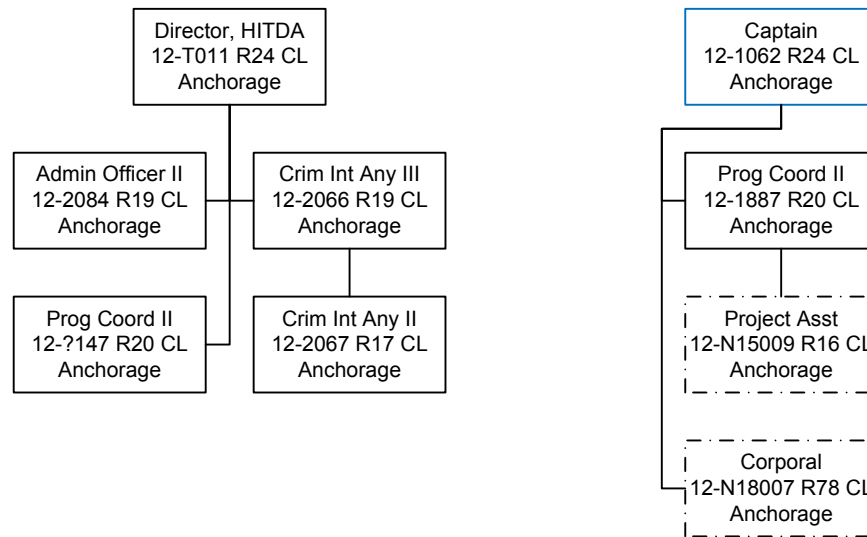

LTNP Position

Not counted in this component, shown for organizational hierarchy.