

State of Alaska FY2023 Governor's Operating Budget

Department of Administration Public Defender Agency Component Budget Summary

Component: Public Defender Agency

Contribution to Department's Mission

To provide constitutionally mandated legal representation to indigent clients appointed by the court.

Results

(Additional performance information is available on the web at <https://omb.alaska.gov/results>.)

Core Services

- Establish timely and effective communications with clients regarding legal rights, legal process, charges and evidence
- Timely review of case materials to advise clients.
- Timely actions taken on behalf of clients.

Measures by Core Service

(Additional performance information is available on the web at <https://omb.alaska.gov/results>.)

1. Establish timely and effective communications with clients regarding legal rights, legal process, charges and evidence

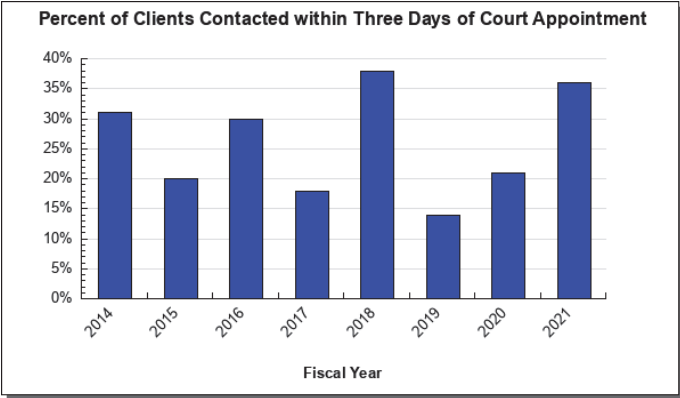

2. Timely review of case materials to advise clients.

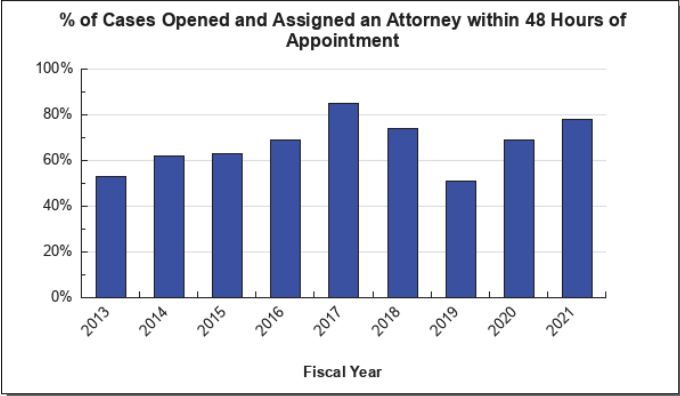

3. Timely actions taken on behalf of clients.

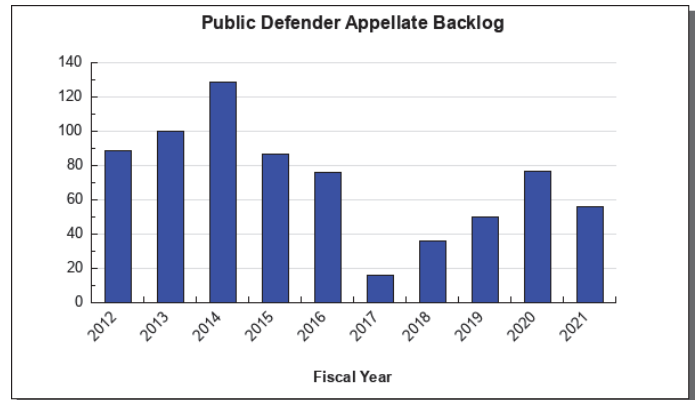
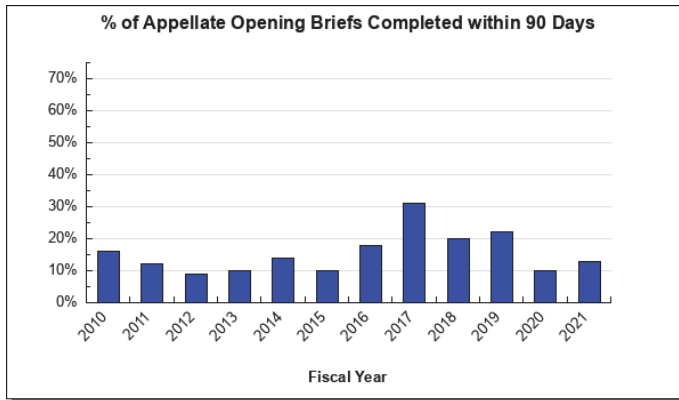

Major Component Accomplishments in 2021

- Expanded scope of centralized administrative and operational oversight of support staff to improve service delivery, coverage, and training.
- Developed and implemented a successful web-based training series for attorneys to ensure continuing legal education requirements.
- Continued successful reduction to the Agency vacancy rate for attorney positions with aggressive recruitment efforts.
- Negotiated and managed a successful office expansion for the Agency’s largest office location to enable workspace for all funded positions.
- Initiated partnership with DHSS to provide increased resources for clients with FASD as part of the Agency’s holistic defense practice model.

Key Component Challenges

Increasing Workloads - The Public Defender Agency (PDA) continues to experience increases in workload per attorney and has been impacted most significantly by the growing backlog of cases created by retention challenges in prior fiscal years and pre-trial delay from COVID-19 mitigation efforts, like the suspension of jury trials and speedy trial rights. The increase in workload, despite successful staffing strategies for remaining attorneys and support staff presents substantial challenges for document processing, client communication, case review and preparation, further exacerbating the slowdown in case dispositions.

Significant Changes in Results to be Delivered in FY2023

Holistic Defense - PDA continues to expand the holistic defense model to provide more direct support for attorneys by assisting clients directly with communication and access to services and community resources.

Efficiency Initiatives - PDA will continue to explore efficiency initiatives and expand or continue the use of those initiated in prior fiscal years such as, support staff time studies and workload reorganization, web-based training opportunities, and centralization of support functions and management.

Re-organization -PDA should begin to see the impact from expanding supervisory and management resources for staff and attorneys. By providing additional supervisory positions and increased operational structures, existing managers should experience some workload relief and attorneys and staff will experience more support in their positions.

Statutory and Regulatory Authority

U.S. Constitution, Amendment VI The Federal Right to Counsel
Alaska Constitution, Article 1, Sec.11 The State Right to Counsel
AS 18.85.010 et seq. The Public Defender Agency Enabling Statute
Alaska Criminal Rule 39 and 39.1
Appellate Rule 209
Financial Eligibility Guidelines for Appointed Counsel

Contact Information

Contact: Samantha Cherot, Public Defender
Phone: (907) 334-4414
E-mail: samantha.cherot@alaska.gov

Public Defender Agency Personal Services Information				
Authorized Positions			Personal Services Costs	
	FY2022 Management Plan	FY2023 Governor		
Full-time	197	201	Annual Salaries	17,787,342
Part-time	1	1	COLA	11,231
Nonpermanent	4	4	Premium Pay	0
			Annual Benefits	10,557,881
			<i>Less 5.00% Vacancy Factor</i>	(1,417,823)
			Lump Sum Premium Pay	0
Totals	202	206	Total Personal Services	26,938,631

Position Classification Summary					
Job Class Title	Anchorage	Fairbanks	Juneau	Others	Total
Accounting Technician 2	1	0	0	0	1
Administrative Assistant 3	1	0	0	0	1
Administrative Officer 1	1	0	0	0	1
Associate Attorney 1	3	1	0	1	5
Associate Attorney 2	1	0	0	0	1
Attorney 1	6	3	0	8	17
Attorney 2	6	3	0	11	20
Attorney 3	9	4	3	5	21
Attorney 4	24	2	3	10	39
Attorney 5	11	2	1	6	20
Attorney 6	4	0	0	0	4
Investigator 1	2	0	0	0	2
Investigator 2	0	0	1	1	2
Investigator 3	3	3	0	5	11
Law Office Assistant 1	16	3	1	6	26
Law Office Assistant 2	3	1	0	4	8
Office Assistant 2	1	0	0	0	1
Paralegal 1	9	0	0	6	15
Paralegal 2	4	2	1	2	9
Program Manager	1	0	0	0	1
Public Defender	1	0	0	0	1
Totals	107	24	10	65	206

Component Detail All Funds
Department of Administration

Component: Public Defender Agency (1631)
RDU: Legal and Advocacy Services (11)

Non-Formula Component

	FY2021 Actuals	FY2022 Conference Committee	FY2022 Authorized	FY2022 Management Plan	FY2023 Governor	FY2022 Management Plan vs FY2023 Governor	
71000 Personal Services	23,809.6	26,881.4	26,795.4	26,795.4	26,938.6	143.2	0.5%
72000 Travel	173.2	529.6	529.6	529.6	536.6	7.0	1.3%
73000 Services	5,132.9	3,936.8	3,936.8	3,936.8	4,234.3	297.5	7.6%
74000 Commodities	233.3	235.1	235.1	235.1	235.1	0.0	0.0%
75000 Capital Outlay	0.0	0.0	0.0	0.0	0.0	0.0	0.0%
77000 Grants, Benefits	0.0	0.0	0.0	0.0	0.0	0.0	0.0%
78000 Miscellaneous	0.0	0.0	0.0	0.0	0.0	0.0	0.0%
Totals	29,349.0	31,582.9	31,496.9	31,496.9	31,944.6	447.7	1.4%
Fund Sources:							
1004 Gen Fund (UGF)	27,088.0	19,727.2	19,727.2	19,727.2	19,500.8	-226.4	-1.1%
1005 GF/Prgm (DGF)	283.9	578.4	578.4	578.4	578.4	0.0	0.0%
1007 I/A Rcpts (Other)	1,249.2	532.4	532.4	532.4	1,219.8	687.4	129.1%
1037 GF/MH (UGF)	554.0	654.8	568.8	568.8	643.5	74.7	13.1%
1092 MHTAAR (Other)	173.9	90.1	90.1	90.1	2.1	-88.0	-97.7%
1271 ARPA Rev R (UGF)	0.0	10,000.0	10,000.0	10,000.0	10,000.0	0.0	0.0%
Unrestricted General (UGF)	27,642.0	30,382.0	30,296.0	30,296.0	30,144.3	-151.7	-0.5%
Designated General (DGF)	283.9	578.4	578.4	578.4	578.4	0.0	0.0%
Other Funds	1,423.1	622.5	622.5	622.5	1,221.9	599.4	96.3%
Federal Funds	0.0	0.0	0.0	0.0	0.0	0.0	0.0%
Positions:							
Permanent Full Time	184	191	191	197	201	4	2.0%
Permanent Part Time	1	1	1	1	1	0	0.0%
Non Permanent	9	9	9	4	4	0	0.0%

Change Record Detail - Multiple Scenarios with Descriptions
Department of Administration

Component: Public Defender Agency (1631)
RDU: Legal and Advocacy Services (11)

Scenario/Change Record Title	Trans Type	Totals	Personal Services	Travel	Services	Commodities	Capital Outlay	Grants, Benefits	Miscellaneous	Positions		NP
										PFT	PPT	
***** Changes From FY2022 Conference Committee To FY2022 Authorized *****												
FY2022 Conference Committee												
	ConfCom	31,582.9	26,881.4	529.6	3,936.8	235.1	0.0	0.0	0.0	191	1	9
1004 Gen Fund		19,727.2										
1005 GF/Prgm		578.4										
1007 I/A Rcpts		532.4										
1037 GF/MH		654.8										
1092 MHTAAR		90.1										
1271 ARPA Rev R		10,000.0										
MH Trust: Holistic Defense - Bethel												
	Veto	-86.0	-86.0	0.0	0.0	0.0	0.0	0.0	0.0	0	0	0
1037 GF/MH		-86.0										
The Mental Health Trust Authority recommended activities and programs for the State's integrated comprehensive mental health program. Funding is better aligned coming from the Trust.												
Subtotal		31,496.9	26,795.4	529.6	3,936.8	235.1	0.0	0.0	0.0	191	1	9

***** Changes From FY2022 Authorized To FY2022 Management Plan *****												
Delete Three Positions Vacant for More Than Six Months												
	PosAdj	0.0	0.0	0.0	0.0	0.0	0.0	0.0	0.0	0	0	-3

Delete three positions that have been vacant for more than six months.

The following positions are deleted:

- Non-permanent Law Office Assistant 2 (02-N07006), range 13, located in Ketchikan
- Non-permanent Law Office Assistant 1 (02-N19013), range 11, located in Bethel
- Non-permanent Law Office Assistant 1 (02-N19019), range 11, located in Nome

Add Attorney 5 (02#161) for Support for Therapeutic Courts												
	PosAdj	0.0	0.0	0.0	0.0	0.0	0.0	0.0	0.0	1	0	0

Per HB71, the Department of Administration, Public Defender Agency will provide attorney services through the mental health operating budget. This position will provide legal support and back-up for administrative meetings, status hearings, team meetings, and trainings to support the goals of Therapeutic Courts.

The following position is added:

Full-time Attorney 5 (02-#161), Range 25, located in Anchorage

Create Permanent Positions for Foster Care Legal Support

Change Record Detail - Multiple Scenarios with Descriptions
Department of Administration

Component: Public Defender Agency (1631)
RDU: Legal and Advocacy Services (11)

Scenario/Change Record Title	Trans Type	Totals	Personal Services	Travel	Services	Commodities	Capital Outlay	Grants, Benefits	Miscellaneous	Positions		
										PFT	PPT	NP
	PosAdj	0.0	0.0	0.0	0.0	0.0	0.0	0.0	0.0	5	0	-2

In FY2022 the Department of Administration replaced various positions across the Department with five permanent full-time positions in the Public Defender Agency to support the foster care legal proceedings. This technical adjustment correctly reflects the approved changes to the positions in the agency.

The following positions are affected:

Delete a non-permanent Law Office Assistant (02-N07033), range 11, Kenai
Delete a non-permanent Law Office Assistant (02-N07037), range 11, Kodiak

Add a full-time Attorney 1/2/3/4 flex (02-1397), range 18/20/22/24, Anchorage
Add a full-time Attorney 1/2/3/4 flex (02-1399), range 18/20/22/24, Palmer
Add a full-time Office Assistant 1 (02-1398), range 11, Anchorage
Add a full-time Office Assistant 2 (02-1400), range 13, Anchorage
Add a full-time Paralegal 1/2 flex (02-1401), range 14/16, Anchorage

Subtotal		31,496.9	26,795.4	529.6	3,936.8	235.1	0.0	0.0	0.0	197	1	4
***** Changes From FY2022 Management Plan To FY2023 Governor *****												

Reverse MH Trust: Holistic Defense - Bethel

	OTI	-86.0	-67.1	-15.0	-3.9	0.0	0.0	0.0	0.0	0	0	0
1092 MHTAAR		-86.0										

Reverse Mental Health Trust recommendation to reflect zero-based mental health budget.

FY2023 General Government Unit SBS and Risk Management Rate Changes

	SalAdj	-1.0	-1.0	0.0	0.0	0.0	0.0	0.0	0.0	0	0	0
1004 Gen Fund		-1.0										

FY2023 Change General Government Unit (GG, GP, GY, GZ) - SBS, and Risk Management Rates: \$-1.0

FY2023 Supervisory Employees Health Insurance, SBS, and Risk Management Rate Changes

	SalAdj	14.9	14.9	0.0	0.0	0.0	0.0	0.0	0.0	0	0	0
1004 Gen Fund		14.9										

FY2023 Change Supervisory Employees (SS) - Health Insurance from \$1,555 to \$1,685; SBS and Risk Management Rates: \$14.9

FY2023 Executive Health Insurance, SBS, and Risk Management Rate Changes

	SalAdj	184.6	184.6	0.0	0.0	0.0	0.0	0.0	0.0	0	0	0
1004 Gen Fund		175.0										
1007 I/A Rcpts		5.2										
1037 GF/MH		3.7										

Change Record Detail - Multiple Scenarios with Descriptions
Department of Administration

Component: Public Defender Agency (1631)
RDU: Legal and Advocacy Services (11)

Scenario/Change Record Title	Trans Type	Totals	Personal Services	Travel	Services	Commodities	Capital Outlay	Grants, Benefits	Miscellaneous	Positions		NP
										PFT	PPT	
1092 MHTAAR		0.7										
FY2023 Change Partially Exempt & Exempt Executive (EE) - Health Insurance from \$1,555 to \$1,685; SBS and Risk Management Rates: \$184.6												
FY2023 PERS Actuarial Rate Adjustment to 24.79% Ch9 SLA2021 (SB55)												
	SalAdj	-889.8	-889.8	0.0	0.0	0.0	0.0	0.0	0.0	0	0	0
1004 Gen Fund		-854.3										
1007 I/A Rcpts		-17.8										
1037 GF/MH		-15.0										
1092 MHTAAR		-2.7										
Includes: FY2023 Adjustment for PERS ARM Board Approved Rate of 24.79% (from 30.11%): \$-889.8												
FY2023 Salary and Benefit Adjustments												
	SalAdj	10.3	10.3	0.0	0.0	0.0	0.0	0.0	0.0	0	0	0
1004 Gen Fund		10.3										
Includes: FY2023 Supervisory Unit 1% COLA: \$4.5												
FY2023 SU BU - Supervisory Employees (SS) 1% COLA: \$5.8												
MH Trust: Holistic Defense - Bethel												
	IncT	86.0	67.1	15.0	3.9	0.0	0.0	0.0	0.0	0	0	0
1037 GF/MH		86.0										

The Public Defender Agency and the Alaska Legal Services Corporation will continue to administer the Holistic Defense model in Bethel, Nome, and Kotzebue and will expand the project to Anchorage in FY2022. The target population will be Trust beneficiaries not participating in the Bethel or Anchorage Therapeutic Courts or other diversion projects and will be randomly selected from clients assigned to the public defender in the Bethel, Nome, Kotzebue and Anchorage regions.

Project participants' legal needs will be addressed by a criminal attorney. A social worker will continue to assist with participants' unmet social support needs and a civil legal aid attorney will work with the team to address project participants' civil legal needs. All program services are designed to address participant obstacles to successful reintegration and self-sufficiency; thus, participant recidivism will be reduced resulting in increased public protection and keeping Alaskans safe.

Use of budget fund code 1268 directs expenditure of money held in reserve in the Mental Health Trust Settlement Income Account in excess of the amount directed for use by the Trust through annual recommendations (State accounting system fund 3321). Per AS 37.14.041(b) money in excess of the amount needed to meet the necessary expenses of the State's integrated comprehensive mental health program shall be transferred to the general fund and used for any public purpose. To ensure these monies are expended to the benefit of the State's mental health program and not swept to the general fund, a portion of the reserves are being utilized to fund various mental health programs and Trust recommendations with the intent of drawing reserves down over a period of five years.

Prepare for Increased Defense Caseload in Response to Sex Crime Increment

Change Record Detail - Multiple Scenarios with Descriptions
Department of Administration

Component: Public Defender Agency (1631)
RDU: Legal and Advocacy Services (11)

Scenario/Change Record Title	Trans Type	Totals	Personal Services	Travel	Services	Commodities	Capital Outlay	Grants, Benefits	Miscellaneous	Positions		
										PFT	PPT	NP
1004 Gen Fund	Inc	428.7	327.3	7.0	94.4	0.0	0.0	0.0	0.0	4	0	0
<p>In FY2022 the Department of Law added ten attorneys and nine additional staff to ramp up prosecutions of sex crimes in Alaska. As each new prosecutor is onboarded and the number of cases filed increases, the Public Defender Agency (PDA) expects to see a drastic increase in the number of annual cases. Funding for seven attorney positions was provided to PDA in response to increase, but after further analysis, it has been determined that will be inadequate to resolve the impending increase in workload, and four additional support staff positions will be required.</p> <p>Without additional funding the Agency risks a cascade of experienced attorneys leaving the Agency, as filings for serious sex crimes increase but the capacity to handle those cases remains stagnant. PDA expects to see a fiscal and operational impact beginning in FY22, and a continued widening of the gap between the need for Agency representation and Agency capacity from year to year without these additional positions.</p> <p>The following positions are added:</p> <ul style="list-style-type: none"> Investigator 1 (02-#168), range 14, located in Anchorage Paralegal 1 (02-#169), range 14 located in Ketchikan Law Office Assistant 1 (02-#171), range 11, located in Anchorage Law Office Assistant 1 (02-#172), range 11, located in Bethel 												
Increase Authority to Align Budget with Annual Interagency Activity												
1007 I/A Rcpts	Inc	700.0	700.0	0.0	0.0	0.0	0.0	0.0	0.0	0	0	0
<p>The Public Defender Agency receives approximately \$1.2 million per year from other Departments in interagency receipts for performing various legal activities on their behalf. The agency currently has half a million dollars in interagency authority. This increment brings the agency's budgeted authority in line with the anticipated amount of interagency receipts for more transparent budgeting.</p>												
Align Authority with Anticipated Expenditures												
	LIT	0.0	-203.1	0.0	203.1	0.0	0.0	0.0	0.0	0	0	0
<p>Transfer authority from personal services to cover anticipated services costs. The remaining personal services authority is sufficient to cover anticipated expenditures.</p>												
Totals		31,944.6	26,938.6	536.6	4,234.3	235.1	0.0	0.0	0.0	201	1	4

Line Item Detail (1676)
Department of Administration
Travel

Component: Public Defender Agency (1631)

Line Number	Line Name		FY2021 Actuals	FY2022 Management Plan	FY2023 Governor
2000	Travel		173.2	529.6	536.6
Object Class	Servicing Agency	Explanation	FY2021 Actuals	FY2022 Management Plan	FY2023 Governor
2000 Travel Detail Totals			173.2	529.6	536.6
2000	In-State Employee Travel	Transportation costs for travel relating to administration, training, conventions and meetings, boards and commissions	100.0	384.6	375.1
2001	In-State Non-Employee Travel	Transportation costs for travel relating to meetings and boards for non-employees	9.1	59.0	50.3
2002	Out of State Employee Travel	Transportation costs for staff travel out of state to national organization meetings, conferences, and training	0.0	15.6	16.8
2003	Out of State Non-Employee Travel	Out of state airfare, surface transportation, lodging and meals and incidentals for expert witnesses and witnesses needed for evaluation, testimony, etc. The PDA has a waiver for all out of state travel expenditures for experts and witnesses.	8.7	15.0	39.0
2005	Moving Costs	Moving and relocation costs	55.4	55.4	55.4

Line Item Detail (1676)
Department of Administration
Services

Component: Public Defender Agency (1631)

Line Number	Line Name		FY2021 Actuals	FY2022 Management Plan	FY2023 Governor
3000	Services		5,132.9	3,936.8	4,234.3
Object Class	Servicing Agency	Explanation	FY2021 Actuals	FY2022 Management Plan	FY2023 Governor
3000 Services Detail Totals			5,132.9	3,936.8	4,234.3
3000	Education Services	Training, educational conferences, agency memberships, and employee tuition	67.6	67.6	7.9
3001	Financial Services	Management and consulting services	0.1	0.0	0.0
3002	Legal and Judicial Services	Contract attorney expenditures related to appellate cases, expert witness fees, transcription services and miscellaneous case costs (medical record requests, etc.).	2,114.2	1,211.4	1,500.5
3003	Information Technology	Software licensing and maintenance, training, and consulting	139.2	129.3	129.3
3004	Telecommunications	Local, long distance, and cellular telephone charges, television, data/network, telecommunication equipment, and other wireless charges from outside vendors	110.6	110.6	110.6
3005	Health Services	Expert witness expenditures related to psychiatric testing and medical lab testing.	27.0	27.0	27.0
3006	Delivery Services	Freight, courier services, and postage	22.9	30.0	35.0
3007	Advertising and Promotions	Advertising, promotions and legal notices	0.5	0.0	0.3
3008	Utilities	Electricity, heating fuel, water, sewage, and disposal services	18.1	18.1	18.1
3009	Structure/Infrastructure/Land	Structure, infrastructure and land	243.7	221.0	221.0

Line Item Detail (1676)
Department of Administration
Services

Component: Public Defender Agency (1631)

Object Class	Servicing Agency	Explanation	FY2021 Actuals	FY2022 Management Plan	FY2023 Governor
3000 Services Detail Totals			5,132.9	3,936.8	4,234.3
		repairs, maintenance, rental, and leases			
3010	Equipment/Machinery	Machinery, furniture and office equipment purchase, repairs, maintenance, rentals, and leases	0.2	2.1	2.1
3011	Other Services	Interpreter services, print and copy services for case related exhibits and Bethel Jesuit Volunteer placement fee	55.7	55.5	55.5
3017	Inter-Agency Information Technology Non-Telecommunications	Admin - Alaska Division of IT (3141) Server hosting fees	57.0	57.0	73.8
3017	Inter-Agency Information Technology Non-Telecommunications	Admin - Alaska Division of IT (3141) OIT Core Services Chargeback	586.0	586.0	586.0
3018	Inter-Agency Information Technology Telecommunications	Admin - Alaska Division of IT (3141) OIT Telecommunications (CISCO device config, deployment, maintenance, replacements, and other telephone line services)	66.4	64.3	64.3
3021	Inter-Agency Mail	Admin - Print Services (2333) Centralized mail services chargeback	4.4	4.1	4.1
3022	Inter-Agency Human Resources	Admin - Personnel (56) DOA - HR chargeback	91.4	91.4	116.4
3023	Inter-Agency Building Leases	Admin - Facilities (2429) Rent for state-owned facilities and lease payments	187.3	185.9	185.9
3023	Inter-Agency Building Leases	Admin - Facilities Administration (2430) Rent for state-owned facilities and lease payments	3.6	0.0	0.0
3023	Inter-Agency Building Leases	Admin - Leases (81) Rent for state-owned facilities and lease payments	578.9	578.9	578.9
3024	Inter-Agency Legal	Courts - Department-wide Transcript (ACS RSA) expenditures	96.9	125.0	125.0
3024	Inter-Agency Legal	Law - Department-wide Discovery (LAW RSA) expenditures	0.0	0.0	40.0
3026	Inter-Agency Insurance	Admin - Risk Management (71) Risk Management chargeback	12.0	12.0	6.5
3027	Inter-Agency Financial	Admin - Accounting (3134) Division of Finance Chargeback for IRIS FIN, HRM, and ALDER	12.1	12.1	10.9

Line Item Detail (1676)
Department of Administration
Services

Component: Public Defender Agency (1631)

Object Class	Servicing Agency	Explanation	FY2021 Actuals	FY2022 Management Plan	FY2023 Governor	
3000 Services Detail Totals			5,132.9	3,936.8	4,234.3	
3027	Inter-Agency Financial	Admin - Finance (59)	Division of Finance Chargeback for IRIS FIN, HRM, and ALDER	11.3	11.3	0.0
3028	Inter-Agency Americans with Disabilities Act Compliance	Admin - Personnel (56)	Americans with Disabilities Act (ADA) Chargeback	1.7	1.7	1.4
3030	Inter-Agency Hearing/Mediation	Admin - Office of Public Advocacy (43)	Hearing Officer services	289.5	0.0	0.0
3038	Inter-Agency Management/Consulting	Admin - Administrative Services (46)	Administrative chargeback for DAS	153.7	153.7	153.0
3038	Inter-Agency Management/Consulting	Admin - Office of the Commissioner (45)	Commissioner's Office chargeback (COM Core Services)	167.6	167.5	167.5
3038	Inter-Agency Management/Consulting	Admin - Stwd Contracting and Property (3262)	CAP Procurement Team (non-OIT) chargeback	13.3	13.3	13.3

Line Item Detail (1676)
Department of Administration
Commodities

Component: Public Defender Agency (1631)

Line Number	Line Name		FY2021 Actuals	FY2022 Management Plan	FY2023 Governor
4000	Commodities		233.3	235.1	235.1
Object Class	Servicing Agency	Explanation	FY2021 Actuals	FY2022 Management Plan	FY2023 Governor
4000 Commodities Detail Totals			233.3	235.1	235.1
4000	Business	General business supplies such as office consumables, furniture, and computer equipment	227.7	230.0	230.6
4002	Household/Institutional	Cleaning, food and other household supplies	4.5	5.1	4.5
4004	Safety	Safety supplies, including fire suppression, personal protection gear	1.1	0.0	0.0

Line Item Detail (1676)
Department of Administration
Grants, Benefits

Component: Public Defender Agency (1631)

Line Number	Line Name		FY2021 Actuals	FY2022 Management Plan	FY2023 Governor
7000	Grants, Benefits		0.0	0.0	0.0
Object Class	Servicing Agency	Explanation	FY2021 Actuals	FY2022 Management Plan	FY2023 Governor
		7000 Grants, Benefits Detail Totals	0.0	0.0	0.0
7001	Grants	AmeriCorps grant program	0.0	0.0	0.0

Revenue Detail (1681)
Department of Administration

Component: Public Defender Agency (1631)

Revenue Type (OMB Fund Code) Revenue Source	Component	Comment	FY2021 Actuals	FY2022 Management Plan	FY2023 Governor
5005 GF/Prgm (1005 GF/Prgm)			351.0	578.4	578.4
5102 Program Receipts Public Protection - Fines and Forfeitures		Rule 39 funds collected from Alaska Permanent Fund garnishments	351.0	578.4	578.4
5007 I/A Rcpts (1007 I/A Rcpts)			1,249.3	1,311.0	1,313.0
5301 Inter-Agency Receipts	Commerce - Department-wide	RSA with Commerce / Serve Alaska (AmeriCorps)	214.6	216.0	218.0
5301 Inter-Agency Receipts	Courts - Department-wide	ACS Therapeutic Court reimbursable services agreement	495.0	495.0	495.0
5301 Inter-Agency Receipts	Health - Department-wide	Title IV-E RSA with HSS	539.7	600.0	600.0
5302 Inter-Agency Receipts - Prior Year Reimbursement Recovery	Commerce - Department-wide	AmeriCorps RSA	0.0	0.0	0.0
6004 Gen Fund (1004 Gen Fund)			2.2	0.0	0.0
6046 General Fund - Prior Year Reimbursement Recovery		Prior year recovery	2.0	0.0	0.0
6047 General Fund - Miscellaneous			0.2	0.0	0.0

Inter-Agency Services (1682)
Department of Administration

Component: Public Defender Agency (1631)

	FY2021 Actuals	FY2022 Management Plan	FY2023 Governor
Component Totals	2,333.1	2,064.2	2,127.0
With Department of Administration	2,236.2	1,939.2	1,962.0
With Judiciary	96.9	125.0	125.0
With Department of Law	0.0	0.0	40.0

Object Class	Servicing Agency	Explanation	FY2021 Actuals	FY2022 Management Plan	FY2023 Governor
3017	Inter-Agency Information Technology Non-Telecommunications	Admin - Alaska Division of IT (3141) Server hosting fees	57.0	57.0	73.8
3017	Inter-Agency Information Technology Non-Telecommunications	Admin - Alaska Division of IT (3141) OIT Core Services Chargeback	586.0	586.0	586.0
3018	Inter-Agency Information Technology Telecommunications	Admin - Alaska Division of IT (3141) OIT Telecommunications (CISCO device config, deployment, maintenance, replacements, and other telephone line services)	66.4	64.3	64.3
3021	Inter-Agency Mail	Admin - Print Services (2333) Centralized mail services chargeback	4.4	4.1	4.1
3022	Inter-Agency Human Resources	Admin - Personnel (56) DOA - HR chargeback	91.4	91.4	116.4
3023	Inter-Agency Building Leases	Admin - Facilities (2429) Rent for state-owned facilities and lease payments	187.3	185.9	185.9
3023	Inter-Agency Building Leases	Admin - Facilities Administration (2430) Rent for state-owned facilities and lease payments	3.6	0.0	0.0
3023	Inter-Agency Building Leases	Admin - Leases (81) Rent for state-owned facilities and lease payments	578.9	578.9	578.9
3024	Inter-Agency Legal	Courts - Department-wide Transcript (ACS RSA) expenditures	96.9	125.0	125.0
3024	Inter-Agency Legal	Law - Department-wide Discovery (LAW RSA) expenditures	0.0	0.0	40.0
3026	Inter-Agency Insurance	Admin - Risk Management (71) Risk Management chargeback	12.0	12.0	6.5
3027	Inter-Agency Financial	Admin - Accounting (3134) Division of Finance Chargeback for IRIS FIN, HRM, and ALDER	12.1	12.1	10.9
3027	Inter-Agency Financial	Admin - Finance (59) Division of Finance Chargeback for IRIS FIN, HRM, and ALDER	11.3	11.3	0.0
3028	Inter-Agency Americans with	Admin - Personnel (56) Americans with Disabilities Act	1.7	1.7	1.4

Inter-Agency Services (1682)
Department of Administration

Component: Public Defender Agency (1631)

Object Class	Servicing Agency	Explanation	FY2021 Actuals	FY2022 Management Plan	FY2023 Governor	
	Disabilities Act Compliance	(ADA) Chargeback				
3030	Inter-Agency Hearing/Mediation	Admin - Office of Public Advocacy (43)	Hearing Officer services	289.5	0.0	0.0
3038	Inter-Agency Management/Consulting	Admin - Administrative Services (46)	Administrative chargeback for DAS	153.7	153.7	153.0
3038	Inter-Agency Management/Consulting	Admin - Office of the Commissioner (45)	Commissioner's Office chargeback (COM Core Services)	167.6	167.5	167.5
3038	Inter-Agency Management/Consulting	Admin - Stwd Contracting and Property (3262)	CAP Procurement Team (non-OIT) chargeback	13.3	13.3	13.3

Personal Services Expenditure Detail
Department of Administration

Scenario: FY2023 Governor (18673)
Component: Public Defender Agency (1631)
RDU: Legal and Advocacy Services (11)

PCN	Job Class Title	Time Status	Retire Code	Barg Unit	Location	Salary Sched	Range / Step	Comp Months	Split / Count	Annual Salaries	COLA	Premium Pay	Annual Benefits	Total Costs	UGF Amount
02-#168	Investigator 1	FT	A	GG	Anchorage	200	14A	12.0		45,084	0	0	35,535	80,619	80,619
02-#169	Paralegal 1	FT	A	GG	Ketchikan	200	14A	12.0		45,084	0	0	35,535	80,619	80,619
02-#171	Law Office Assistant 1	FT	A	GG	Anchorage	200	11A	12.0		37,460	0	0	32,701	70,161	70,161
02-#172	Law Office Assistant 1	FT	A	GG	Bethel	250	11A	12.0		56,199	0	0	39,665	95,864	95,864
02-?154	Attorney 1	FT	A	XE	Anchorage	N00	18C / D	12.0		66,593	0	0	44,983	111,576	111,576
02-?155	Attorney 1	FT	A	XE	Anchorage	N00	18C / D	12.0		66,593	0	0	44,983	111,576	111,576
02-?156	Attorney 1	FT	A	XE	Bethel	N50	18F / J	12.0		110,370	0	0	61,251	171,621	171,621
02-?157	Attorney 1	FT	A	XE	Fairbanks	N03	18C / D	12.0		68,601	0	0	45,729	114,330	114,330
02-?158	Attorney 1	FT	A	XE	Kenai	N00	18C / D	12.0		66,593	0	0	44,983	111,576	111,576
02-?159	Attorney 1	FT	A	XE	Ketchikan	N00	18C / D	12.0		66,593	0	0	44,983	111,576	111,576
02-?160	Attorney 1	FT	A	XE	Kotzebue	N60	18C / D	12.0		106,568	0	0	59,838	166,406	166,406
02-?161	Attorney 5	FT	A	XE	Anchorage	N00	25C / D	12.0		106,451	0	0	59,794	166,245	166,245
02-1101	Law Office Assistant 2	FT	A	GP	Dillingham	237	13J	12.0		74,607	0	0	46,505	121,112	121,112
02-1102	Law Office Assistant 1	FT	A	GP	Palmer	200	11D / E	12.0		41,339	0	0	34,143	75,482	75,482
02-1103	Investigator 2	FT	A	GP	Juneau	205	16B / C	12.0		57,815	0	0	40,265	98,080	98,080
02-1104	Law Office Assistant 1	FT	A	GP	Anchorage	200	11B / C	12.0		39,601	0	0	33,497	73,098	73,098
02-1106	Attorney 3	FT	A	XE	Palmer	N00	22D / E	12.0		88,616	0	0	53,167	141,783	141,783
02-1108	Investigator 3	FT	A	GP	Palmer	200	18J / K	12.0		77,435	0	0	47,556	124,991	124,991
02-1109	Attorney 4	FT	A	XE	Anchorage	N00	24E / F	12.0		104,715	0	0	59,149	163,864	163,864
02-1117	Attorney 5	FT	A	XE	Kotzebue	N60	25E / F	12.0		180,869	0	0	85,354	266,223	266,223
02-1118	Attorney 2	FT	A	XE	Palmer	N00	20F / J	12.0		82,358	0	0	50,842	133,200	133,200
02-1119	Investigator 3	FT	A	GP	Fairbanks	203	18G	12.0		75,972	0	0	47,013	122,985	122,985
02-1120	Paralegal 2	FT	A	GP	Fairbanks	203	16J	12.0		69,206	0	0	44,498	113,704	113,704
02-1121	Attorney 1	FT	A	XE	Anchorage	N00	18F	12.0		71,273	0	0	46,722	117,995	117,995
02-1122	Attorney 2	FT	A	XE	Anchorage	N00	20E / F	12.0		80,061	0	0	49,988	130,049	130,049
02-1123	Attorney 5	FT	A	XE	Palmer	N00	25M / N	12.0		133,870	0	0	69,983	203,853	203,853
02-1124	Attorney 5	FT	A	XE	Bethel	N50	25F / J	12.0		173,963	0	0	83,211	257,174	257,174
02-1127	Investigator 3	FT	A	GP	Kodiak	211	18E / F	12.0		79,224	0	0	48,221	127,445	127,445
02-1128	Attorney 2	FT	A	XE	Anchorage	N00	20F / J	12.0		81,722	0	0	50,605	132,327	132,327
02-1129	Law Office Assistant 1	FT	A	GP	Anchorage	200	11F / G	12.0		44,545	0	0	35,334	79,879	79,879
02-1130	Attorney 3	FT	A	XE	Anchorage	N00	22C / D	12.0		85,892	0	0	52,155	138,047	79,609
02-1133	Attorney 4	FT	A	XE	Anchorage	N00	24F	12.0		106,451	0	0	59,794	166,245	166,245
02-1134	Attorney 5	FT	A	XE	Anchorage	N00	25F / J	12.0		116,742	0	0	63,619	180,361	180,361
02-1135	Paralegal 2	FT	A	GP	Juneau	205	16A / B	12.0		56,499	0	0	39,776	96,275	96,275
02-1201	Public Defender	FT	A	XE	Anchorage	N00	27O	12.0		149,019	0	0	75,471	224,490	174,089
02-1202	Administrative Assistant 3	FT	A	SS	Anchorage	600	15P	12.0		78,624	1,078	0	49,598	129,300	129,300
02-1203	Law Office Assistant 1	FT	A	GP	Anchorage	200	11A	12.0		37,830	0	0	32,839	70,669	70,669
02-1204	Law Office Assistant 2	FT	A	GP	Ketchikan	200	13B / C	12.0		44,571	0	0	35,344	79,915	79,915

Note: If a position is split, an asterisk (*) will appear in the Split/Count column. If the split position is also counted in the component, two asterisks (**) will appear in this column. [No valid job title] appearing in the Job Class Title indicates that the PCN has an invalid class code or invalid range for the class code effective date of this scenario.

Personal Services Expenditure Detail
Department of Administration

Scenario: FY2023 Governor (18673)
Component: Public Defender Agency (1631)
RDU: Legal and Advocacy Services (11)

PCN	Job Class Title	Time Status	Retire Code	Barg Unit	Location	Salary Sched	Range / Step	Comp Months	Split / Count	Annual Salaries	COLA	Premium Pay	Annual Benefits	Total Costs	UGF Amount
02-1205	Law Office Assistant 1	FT	A	GP	Anchorage	200	11A / B	12.0		37,921	0	0	32,873	70,794	70,794
02-1206	Attorney 5	FT	A	XE	Fairbanks	N03	25L / M	12.0		133,049	0	0	69,678	202,727	202,727
02-1207	Attorney 3	FT	A	XE	Juneau	N05	22E	12.0		94,244	0	0	55,258	149,502	149,502
02-1208	Attorney 4	FT	A	XE	Sitka	N05	24B / C	12.0		100,854	0	0	57,715	158,569	158,569
02-1209	Attorney 5	FT	A	XE	Fairbanks	N03	25K / L	12.0		129,103	0	0	68,212	197,315	197,315
02-1210	Attorney 5	FT	A	XE	Anchorage	N00	25K / L	12.0		124,447	0	0	66,482	190,929	190,929
02-1211	Attorney 5	FT	A	XE	Anchorage	N00	25P / Q	12.0		146,998	0	0	74,843	221,841	221,841
02-1212	Investigator 3	FT	A	SS	Anchorage	600	18A / B	12.0		65,199	894	0	44,609	110,702	110,702
02-1213	Paralegal 1	FT	A	GP	Anchorage	200	14B / C	12.0		48,251	0	0	36,711	84,962	84,962
02-1214	Law Office Assistant 1	FT	A	GP	Anchorage	200	11C / D	12.0		40,114	0	0	33,688	73,802	73,802
02-1215	Law Office Assistant 2	FT	A	SS	Fairbanks	603	13D / E	12.0		53,541	734	0	40,277	94,552	94,552
02-1216	Attorney 2	FT	A	XE	Fairbanks	N03	20E / F	12.0		82,700	0	0	50,969	133,669	133,669
02-1217	Investigator 2	FT	A	GP	Ketchikan	200	16K / L	12.0		70,437	0	0	44,956	115,393	115,393
02-1218	Attorney 1	FT	A	XE	Anchorage	N00	18M / N	12.0		81,861	0	0	50,657	132,518	132,518
02-1219	Investigator 3	FT	A	GP	Fairbanks	203	18C	12.0		66,456	0	0	43,476	109,932	109,932
02-1220	Attorney 6	FT	A	XE	Anchorage	N00	26B / C	12.0		103,847	0	0	58,827	162,674	162,674
02-1221	Attorney 5	FT	A	XE	Anchorage	99	25R	12.0		157,075	0	0	77,970	235,045	235,045
02-1222	Attorney 5	FT	A	XE	Anchorage	N00	25N / O	12.0		136,988	0	0	71,142	208,130	208,130
02-1223	Attorney 3	FT	A	XE	Kenai	N00	22E / F	12.0		91,375	0	0	54,192	145,567	145,567
02-1224	Attorney 3	FT	A	XE	Anchorage	N00	22B / C	12.0		83,660	0	0	51,325	134,985	134,985
02-1225	Attorney 5	FT	A	XE	Anchorage	99	25N	12.0		140,657	0	0	72,505	213,162	213,162
02-1226	Attorney 6	FT	A	XE	Anchorage	N00	26J / K	12.0		124,031	0	0	66,327	190,358	190,358
02-1227	Law Office Assistant 1	FT	A	GP	Anchorage	200	11C / D	12.0		40,606	0	0	33,871	74,477	74,477
02-1228	Law Office Assistant 1	FT	A	GP	Anchorage	200	11C / D	12.0		40,913	0	0	33,985	74,898	74,898
02-1229	Law Office Assistant 1	FT	A	GP	Kenai	200	11E / F	12.0		42,720	0	0	34,656	77,376	77,376
02-1230	Attorney 5	FT	A	XE	Anchorage	N00	25F / J	12.0		116,896	0	0	63,676	180,572	180,572
02-1231	Attorney 4	FT	A	XE	Anchorage	N00	24F / J	12.0		108,464	0	0	60,543	169,007	169,007
02-1232	Accounting Technician 2	FT	A	GP	Anchorage	200	14B / C	12.0		47,527	0	0	36,442	83,969	83,969
02-1234	Attorney 3	FT	A	XE	Anchorage	N00	22E / F	12.0		90,248	0	0	53,773	144,021	144,021
02-1235	Attorney 4	FT	A	XE	Juneau	N05	24E / F	12.0		109,647	0	0	60,982	170,629	170,629
02-1236	Attorney 5	FT	A	XE	Anchorage	99	25R / S	12.0		161,329	0	0	79,290	240,619	240,619
02-1238	Attorney 1	FT	A	XE	Ketchikan	N00	18F / J	12.0		73,593	0	0	47,584	121,177	121,177
02-1239	Attorney 3	FT	A	XE	Fairbanks	N03	22M / N	12.0		112,359	0	0	61,990	174,349	174,349
02-1240	Attorney 1	FT	A	XE	Fairbanks	N03	18F / J	12.0		74,997	0	0	48,106	123,103	123,103
02-1242	Attorney 4	FT	A	XE	Juneau	N05	24R	12.0		149,039	0	0	75,477	224,516	224,516
02-1243	Attorney 2	FT	A	XE	Anchorage	N00	20E / F	12.0		81,393	0	0	50,483	131,876	131,876
02-1244	Law Office Assistant 1	FT	A	GP	Anchorage	200	11A / B	12.0		38,103	0	0	32,940	71,043	71,043
02-1245	Paralegal 1	FT	A	GP	Bethel	250	14B / C	12.0		72,182	0	0	45,604	117,786	117,786

Note: If a position is split, an asterisk (*) will appear in the Split/Count column. If the split position is also counted in the component, two asterisks (**) will appear in this column. [No valid job title] appearing in the Job Class Title indicates that the PCN has an invalid class code or invalid range for the class code effective date of this scenario.

Personal Services Expenditure Detail
Department of Administration

Scenario: FY2023 Governor (18673)
Component: Public Defender Agency (1631)
RDU: Legal and Advocacy Services (11)

PCN	Job Class Title	Time Status	Retire Code	Barg Unit	Location	Salary Sched	Range / Step	Comp Months	Split / Count	Annual Salaries	COLA	Premium Pay	Annual Benefits	Total Costs	UGF Amount
02-1246	Attorney 1	FT	A	XE	Bethel	N50	18M	12.0		121,485	0	0	65,381	186,866	186,866
02-1247	Attorney 5	FT	A	XE	Juneau	99	25S	12.0		171,117	0	0	82,328	253,445	253,445
02-1248	Attorney 3	FT	A	XE	Kenai	N00	22E	12.0		89,739	0	0	53,584	143,323	143,323
02-1249	Attorney 4	FT	A	XE	Anchorage	N00	24B / C	12.0		93,990	0	0	55,164	149,154	78,674
02-1250	Paralegal 2	FT	A	GP	Anchorage	200	16E / F	12.0		61,129	0	0	41,497	102,626	102,626
02-1251	Attorney 5	FT	A	XE	Kenai	N00	25J	12.0		118,131	0	0	64,135	182,266	182,266
02-1253	Attorney 1	FT	A	XE	Nome	N37	18E / F	12.0		96,655	0	0	56,154	152,809	152,809
02-1254	Paralegal 1	FT	A	SS	Anchorage	600	14C / D	12.0		54,642	749	0	40,686	96,077	96,077
02-1255	Law Office Assistant 2	FT	A	GP	Kotzebue	260	13E / F	12.0		80,769	0	0	48,795	129,564	129,564
02-1256	Attorney 4	FT	A	XE	Kotzebue	N60	24E / F	12.0		169,171	0	0	81,724	250,895	250,895
02-1258	Paralegal 1	FT	A	GP	Utqiagvik	250	14K	12.0		90,363	0	0	52,360	142,723	142,723
02-1259	Law Office Assistant 1	FT	A	GP	Fairbanks	203	11B / C	12.0		40,238	0	0	33,734	73,972	73,972
02-1260	Attorney 1	FT	A	XE	Fairbanks	N03	18B / C	12.0		65,329	0	0	44,514	109,843	55,984
02-1261	Attorney 3	FT	A	XE	Fairbanks	N03	22C / D	12.0		89,525	0	0	53,505	143,030	143,030
02-1262	Attorney 3	FT	A	XE	Juneau	N05	22F / J	12.0		99,206	0	0	57,102	156,308	118,292
02-1263	Attorney 3	FT	A	XE	Anchorage	N00	22D / E	12.0		88,218	0	0	53,019	141,237	141,237
02-1264	Attorney 3	FT	A	XE	Anchorage	N00	22C / D	12.0		84,143	0	0	51,505	135,648	135,648
02-1265	Attorney 3	FT	A	XE	Juneau	N05	22C / D	12.0		90,933	0	0	54,028	144,961	144,961
02-1266	Attorney 2	FT	A	XE	Palmer	N00	20E / F	12.0		79,650	0	0	49,835	129,485	129,485
02-1267	Attorney 4	FT	A	XE	Fairbanks	N03	24L / M	12.0		122,809	0	0	65,873	188,682	188,682
02-1268	Investigator 3	FT	A	GP	Nome	237	18D / E	12.0		93,582	0	0	53,556	147,138	147,138
02-1269	Attorney 4	FT	A	XE	Juneau	N05	24E / F	12.0		109,465	0	0	60,914	170,379	170,379
02-1270	Attorney 4	FT	A	XE	Palmer	99	24O / P	12.0		134,940	0	0	70,381	205,321	205,321
02-1271	Paralegal 1	FT	A	GP	Anchorage	200	14B / C	12.0		47,264	0	0	36,345	83,609	83,609
02-1272	Attorney 3	FT	A	XE	Anchorage	N00	22E / F	12.0		92,608	0	0	54,650	147,258	147,258
02-1273	Law Office Assistant 2	FT	A	GP	Kodiak	211	13A / B	12.0		48,688	0	0	36,874	85,562	85,562
02-1274	Law Office Assistant 1	FT	A	GP	Anchorage	200	11K	12.0		48,965	0	0	36,977	85,942	85,942
02-1275	Investigator 1	FT	A	GP	Anchorage	200	14B / C	12.0		47,185	0	0	36,315	83,500	83,500
02-1276	Attorney 3	FT	A	XE	Fairbanks	N03	22F	12.0		95,745	0	0	55,816	151,561	151,561
02-1277	Attorney 4	FT	A	XE	Anchorage	N00	24L	12.0		117,176	0	0	63,780	180,956	180,956
02-1278	Attorney 6	FT	A	XE	Anchorage	N00	26P	12.0		148,259	0	0	75,235	223,494	223,494
02-1279	Attorney 3	FT	A	XE	Anchorage	N00	22B	12.0		121,568	0	0	65,412	186,980	186,980
02-1280	Attorney 4	FT	A	XE	Anchorage	N00	24L	12.0		117,176	0	0	63,780	180,956	180,956
02-1281	Office Assistant 2	PT	A	GP	Anchorage	99	10P	8.0		36,241	0	0	19,728	55,969	55,969
02-1282	Attorney 3	FT	A	XE	Anchorage	N00	22D / E	12.0		88,920	0	0	53,280	142,200	142,200
02-1283	Paralegal 1	FT	A	GP	Sitka	205	14N / O	12.0		70,452	0	0	44,961	115,413	115,413
02-1284	Attorney 2	FT	A	XE	Palmer	N00	20E / F	12.0		80,231	0	0	50,051	130,282	130,282
02-1286	Associate Attorney 1	FT	A	XE	Fairbanks	N03	17K	12.0		73,125	0	0	47,411	120,536	0

Note: If a position is split, an asterisk (*) will appear in the Split/Count column. If the split position is also counted in the component, two asterisks (**) will appear in this column. [No valid job title] appearing in the Job Class Title indicates that the PCN has an invalid class code or invalid range for the class code effective date of this scenario.

Personal Services Expenditure Detail
Department of Administration

Scenario: FY2023 Governor (18673)
Component: Public Defender Agency (1631)
RDU: Legal and Advocacy Services (11)

PCN	Job Class Title	Time Status	Retire Code	Barg Unit	Location	Salary Sched	Range / Step	Comp Months	Split / Count	Annual Salaries	COLA	Premium Pay	Annual Benefits	Total Costs	UGF Amount
02-1287	Investigator 3	FT	A	SS	Bethel	250	18R / S	12.0		162,157	2,125	0	79,691	243,973	243,973
02-1288	Investigator 3	FT	A	GP	Fairbanks	203	18C / D	12.0		67,607	0	0	43,904	111,511	111,511
02-1289	Paralegal 1	FT	A	GP	Anchorage	200	14B / C	12.0		47,290	0	0	36,354	83,644	83,644
02-1290	Attorney 4	FT	A	XE	Anchorage	N00	24D / E	12.0		102,399	0	0	58,289	160,688	160,688
02-1291	Attorney 1	FT	A	XE	Anchorage	N00	18E / F	12.0		70,271	0	0	46,350	116,621	116,621
02-1292	Attorney 4	FT	A	XE	Palmer	N00	24F	12.0		106,451	0	0	59,794	166,245	166,245
02-1293	Attorney 5	FT	A	XE	Palmer	N00	25A / B	12.0		96,298	0	0	56,022	152,320	152,320
02-1296	Attorney 4	FT	A	XE	Kenai	N00	24K / L	12.0		117,176	0	0	63,780	180,956	180,956
02-1297	Law Office Assistant 2	FT	A	SS	Anchorage	600	13C / D	12.0		50,330	690	0	39,084	90,104	90,104
02-1298	Attorney 6	FT	A	XE	Anchorage	99	26R	12.0		162,701	0	0	79,716	242,417	242,417
02-1299	Attorney 2	FT	A	XE	Kenai	N00	20E / F	12.0		78,730	0	0	49,493	128,223	128,223
02-1300	Attorney 2	FT	A	XE	Nome	N37	20E / F	12.0		110,175	0	0	61,178	171,353	171,353
02-1305	Paralegal 2	FT	A	GP	Palmer	200	16K	12.0		69,381	0	0	44,563	113,944	113,944
02-1320	Law Office Assistant 1	FT	A	GP	Palmer	200	11P	12.0		57,467	0	0	40,136	97,603	97,603
02-1321	Law Office Assistant 1	FT	A	GP	Anchorage	200	11D / E	12.0		41,685	0	0	34,271	75,956	75,956
02-1322	Attorney 2	FT	A	XE	Fairbanks	N03	20E / F	12.0		81,440	0	0	50,500	131,940	131,940
02-1323	Attorney 2	FT	A	XE	Bethel	N50	20F / J	12.0		122,301	0	0	65,684	187,985	187,985
02-1324	Attorney 4	FT	A	XE	Anchorage	N00	24C	12.0		96,057	0	0	55,932	151,989	151,989
02-1325	Attorney 2	FT	A	XE	Ketchikan	N00	20M / N	12.0		95,234	0	0	55,626	150,860	150,860
02-1326	Attorney 4	FT	A	XE	Anchorage	N00	24F / J	12.0		106,594	0	0	59,848	166,442	166,442
02-1327	Attorney 4	FT	A	XE	Anchorage	N00	24F	12.0		106,451	0	0	59,794	166,245	166,245
02-1328	Attorney 3	FT	A	XE	Kenai	N00	22C / D	12.0		86,297	0	0	52,305	138,602	138,602
02-1329	Attorney 4	FT	A	XE	Anchorage	N00	24K / L	12.0		113,920	0	0	62,570	176,490	176,490
02-1330	Investigator 3	FT	A	GP	Anchorage	200	18B / C	12.0		63,471	0	0	42,367	105,838	105,838
02-1331	Attorney 4	FT	A	XE	Anchorage	99	24M / N	12.0		122,226	0	0	65,656	187,882	187,882
02-1332	Attorney 2	FT	A	XE	Palmer	N00	20C	12.0		73,496	0	0	47,548	121,044	121,044
02-1333	Attorney 2	FT	A	XE	Bethel	N50	20E / F	12.0		120,086	0	0	64,861	184,947	184,947
02-1334	Attorney 4	FT	A	XE	Anchorage	99	24O / P	12.0		134,586	0	0	70,249	204,835	204,835
02-1335	Attorney 5	FT	A	XE	Dillingham	N37	25M	12.0		178,133	0	0	84,505	262,638	262,638
02-1336	Attorney 5	FT	A	XE	Anchorage	N00	25E / F	12.0		111,443	0	0	61,650	173,093	173,093
02-1338	Law Office Assistant 1	FT	A	GP	Anchorage	200	11B / C	12.0		39,205	0	0	33,350	72,555	72,555
02-1339	Attorney 4	FT	A	XE	Anchorage	N00	24F	12.0		106,451	0	0	59,794	166,245	166,245
02-1341	Law Office Assistant 1	FT	A	GP	Kenai	200	11G / J	12.0		46,163	0	0	35,935	82,098	82,098
02-1342	Attorney 5	FT	A	XE	Anchorage	99	25P / Q	12.0		150,068	0	0	75,796	225,864	225,864
02-1343	Attorney 4	FT	A	XE	Anchorage	N00	24F / K	12.0		111,495	0	0	61,669	173,164	173,164
02-1344	Attorney 4	FT	A	XE	Anchorage	N00	24M / N	12.0		123,604	0	0	66,169	189,773	189,773
02-1345	Paralegal 1	FT	A	GP	Anchorage	200	14B / C	12.0		48,567	0	0	36,829	85,396	85,396
02-1346	Attorney 4	FT	A	XE	Anchorage	N00	24M / N	12.0		124,261	0	0	66,413	190,674	190,674

Note: If a position is split, an asterisk (*) will appear in the Split/Count column. If the split position is also counted in the component, two asterisks (**) will appear in this column. [No valid job title] appearing in the Job Class Title indicates that the PCN has an invalid class code or invalid range for the class code effective date of this scenario.

Personal Services Expenditure Detail
Department of Administration

Scenario: FY2023 Governor (18673)
Component: Public Defender Agency (1631)
RDU: Legal and Advocacy Services (11)

PCN	Job Class Title	Time Status	Retire Code	Barg Unit	Location	Salary Sched	Range / Step	Comp Months	Split / Count	Annual Salaries	COLA	Premium Pay	Annual Benefits	Total Costs	UGF Amount
02-1347	Paralegal 2	FT	A	GP	Anchorage	200	16F / G	12.0		63,364	0	0	42,327	105,691	105,691
02-1348	Attorney 4	FT	A	XE	Anchorage	N00	24C / D	12.0		97,380	0	0	56,424	153,804	106,243
02-1349	Attorney 3	FT	A	XE	Fairbanks	N03	22C / D	12.0		89,187	0	0	53,379	142,566	142,566
02-1350	Attorney 4	FT	A	XE	Kenai	N00	24J	12.0		109,902	0	0	61,077	170,979	170,979
02-1351	Associate Attorney 2	FT	A	XE	Anchorage	99	19M / N	12.0		88,541	0	0	53,139	141,680	141,680
02-1352	Law Office Assistant 1	FT	A	GP	Anchorage	200	11D / E	12.0		42,608	0	0	34,614	77,222	77,222
02-1354	Paralegal 1	FT	A	GP	Anchorage	200	14B / C	12.0		48,146	0	0	36,672	84,818	84,818
02-1355	Attorney 4	FT	A	XE	Anchorage	N00	24D / E	12.0		101,736	0	0	58,042	159,778	159,778
02-1357	Law Office Assistant 1	FT	A	GP	Anchorage	200	11C / D	12.0		41,026	0	0	34,027	75,053	75,053
02-1358	Attorney 4	FT	A	XE	Anchorage	N00	24B / C	12.0		94,636	0	0	55,404	150,040	105,028
02-1359	Attorney 4	FT	A	XE	Kenai	N00	24D / E	12.0		101,736	0	0	58,042	159,778	159,778
02-1360	Attorney 4	FT	A	XE	Anchorage	N00	24F / J	12.0		107,313	0	0	60,115	167,428	167,428
02-1361	Attorney 3	FT	A	XE	Bethel	N50	22C / D	12.0		129,442	0	0	68,338	197,780	197,780
02-1362	Investigator 3	FT	A	GP	Anchorage	200	18F / G	12.0		71,601	0	0	45,388	116,989	116,989
02-1363	Attorney 4	FT	A	XE	Palmer	N00	24F / J	12.0		106,681	0	0	59,880	166,561	107,389
02-1364	Administrative Officer 1	FT	A	SS	Anchorage	200	17E / F	12.0		72,207	990	0	47,213	120,410	120,410
02-1365	Paralegal 2	FT	A	GP	Fairbanks	203	16D	12.0		59,846	0	0	41,020	100,866	100,866
02-1366	Paralegal 1	FT	A	GP	Kenai	200	14E / F	12.0		53,924	0	0	38,819	92,743	92,743
02-1367	Paralegal 2	FT	A	GP	Anchorage	200	16J	12.0		67,197	0	0	43,752	110,949	110,949
02-1370	Paralegal 2	FT	A	GP	Palmer	200	16E / F	12.0		60,861	0	0	41,397	102,258	102,258
02-1371	Paralegal 1	FT	A	GP	Anchorage	200	14E / F	12.0		53,209	0	0	38,554	91,763	91,763
02-1372	Investigator 3	FT	A	SS	Kenai	600	18J / K	12.0		82,068	1,126	0	50,878	134,072	134,072
02-1373	Associate Attorney 1	FT	A	XE	Bethel	N50	17J	12.0		103,136	0	0	58,563	161,699	161,699
02-1374	Associate Attorney 1	FT	A	XE	Anchorage	N00	17B / C	12.0		58,139	0	0	41,842	99,981	99,981
02-1375	Attorney 2	FT	A	XE	Anchorage	N00	20E	12.0		78,488	0	0	49,403	127,891	127,891
02-1376	Attorney 4	FT	A	XE	Anchorage	N00	24J	12.0		109,902	0	0	61,077	170,979	170,979
02-1377	Attorney 4	FT	A	XE	Anchorage	N00	24L	12.0		117,176	0	0	63,780	180,956	180,956
02-1378	Program Manager	FT	A	SS	Anchorage	200	22K / L	12.0		108,866	1,493	0	60,836	171,195	171,195
02-1379	Associate Attorney 1	FT	A	XE	Anchorage	N00	17F	12.0		66,593	0	0	44,983	111,576	111,576
02-1380	Attorney 3	FT	A	XE	Anchorage	N00	22D / E	12.0		87,399	0	0	52,715	140,114	90,557
02-1381	Attorney 4	FT	A	XE	Anchorage	N00	24F	12.0		106,451	0	0	59,794	166,245	166,245
02-1382	Attorney 4	FT	A	XE	Bethel	N50	24F / J	12.0		163,489	0	0	79,961	243,450	243,450
02-1383	Attorney 4	FT	A	XE	Fairbanks	N03	24E / F	12.0		108,004	0	0	60,372	168,376	168,376
02-1384	Attorney 1	FT	A	XE	Bethel	N50	18E / F	12.0		103,162	0	0	58,572	161,734	161,734
02-1385	Attorney 2	FT	A	XE	Kodiak	N11	20C	12.0		81,588	0	0	50,555	132,143	132,143
02-1386	Attorney 2	FT	A	XE	Anchorage	N00	20D / E	12.0		77,970	0	0	49,211	127,181	127,181
02-1388	Attorney 4	FT	A	XE	Ketchikan	N00	24J	12.0		109,902	0	0	61,077	170,979	170,979
02-1389	Attorney 2	FT	A	XE	Fairbanks	N03	20D / E	12.0		79,737	0	0	49,868	129,605	129,605

Note: If a position is split, an asterisk (*) will appear in the Split/Count column. If the split position is also counted in the component, two asterisks (**) will appear in this column. [No valid job title] appearing in the Job Class Title indicates that the PCN has an invalid class code or invalid range for the class code effective date of this scenario.

Personal Services Expenditure Detail
Department of Administration

Scenario: FY2023 Governor (18673)
Component: Public Defender Agency (1631)
RDU: Legal and Advocacy Services (11)

PCN	Job Class Title	Time Status	Retire Code	Barg Unit	Location	Salary Sched	Range / Step	Comp Months	Split / Count	Annual Salaries	COLA	Premium Pay	Annual Benefits	Total Costs	UGF Amount
02-1390	Law Office Assistant 1	FT	A	GP	Fairbanks	203	11D / E	12.0		42,708	0	0	34,652	77,360	77,360
02-1391	Law Office Assistant 1	FT	A	GP	Juneau	205	11D / E	12.0		44,611	0	0	35,359	79,970	79,970
02-1392	Law Office Assistant 2	FT	A	SS	Anchorage	600	13B / C	12.0		48,461	665	0	38,389	87,515	87,515
02-1393	Paralegal 2	FT	A	GP	Anchorage	200	16B / C	12.0		55,261	0	0	39,316	94,577	94,577
02-1394	Paralegal 1	FT	A	GP	Nome	237	14D / E	12.0		71,272	0	0	45,266	116,538	116,538
02-1395	Paralegal 1	FT	A	GP	Anchorage	200	14E / F	12.0		53,567	0	0	38,687	92,254	92,254
02-1396	Associate Attorney 1	FT	A	XE	Anchorage	N00	17E / F	12.0		65,956	0	0	44,747	110,703	110,703
02-1397	Attorney 2	FT	A	XE	Anchorage	N00	20E / F	12.0		80,642	0	0	50,204	130,846	0
02-1398	Law Office Assistant 1	FT	A	GG	Anchorage	200	11A / B	12.0		38,175	0	0	32,967	71,142	0
02-1399	Attorney 2	FT	A	XE	Palmer	N00	20E / F	12.0		80,400	0	0	50,114	130,514	0
02-1400	Law Office Assistant 2	FT	A	SS	Anchorage	600	13C / D	12.0		50,083	687	0	38,992	89,762	0
02-1401	Paralegal 1	FT	A	GP	Anchorage	200	14A	12.0		45,533	0	0	35,701	81,234	0
02-N07033	Law Office Assistant 1	NP	N	GP	Kenai	200	11A	0.5		0	0	0	0	0	0
02-N07035	Law Office Assistant 1	NP	N	GP	Anchorage	200	11A	3.0		7,205	0	0	686	7,891	7,891
02-N07037	Law Office Assistant 1	NP	N	GP	Kodiak	211	11A	0.5		0	0	0	0	0	0
02-N07039	Law Office Assistant 1	NP	N	GP	Palmer	200	11A	0.5		252	0	0	24	276	276
02-N07043	Law Office Assistant 1	NP	N	GP	Fairbanks	203	11A	0.5		999	0	0	95	1,094	1,094
02-TPX002	Attorney 1	NP	N	XE	Anchorage	N00	18F	12.0		71,273	0	0	6,785	78,058	78,058

Total Positions				Total Salary Costs:	17,787,342
Full Time Positions:	201	9	0	Total COLA:	11,231
Part Time Positions:	1	0	0	Total Premium Pay:	0
Non Permanent Positions:	4	0	2	Total Benefits:	10,557,881
Positions in Component:	206	9	2	Total Pre-Vacancy:	28,356,454
				Minus Vacancy Adjustment of 5.00%:	(1,417,823)
				Total Post-Vacancy:	26,938,631
Total Component Months:	2,436.0			Plus Lump Sum Premium Pay:	0
				Personal Services Line 100:	26,938,631

PCN Funding Sources:	Pre-Vacancy	Post-Vacancy	Percent
1004 General Fund Receipts	26,551,471	25,223,898	93.63%
1007 Interagency Receipts	1,158,302	1,100,386	4.08%
1037 General Fund / Mental Health	646,681	614,347	2.28%
Total PCN Funding:	28,356,454	26,938,631	100.00%

Note: If a position is split, an asterisk (*) will appear in the Split/Count column. If the split position is also counted in the component, two asterisks (**) will appear in this column. [No valid job title] appearing in the Job Class Title indicates that the PCN has an invalid class code or invalid range for the class code effective date of this scenario.

Department of Administration
 Public Defender Agency (1631)
 RDU: Legal & Advocacy Services (11)
 FY2023 Governor's Budget
 Position Totals: 203 PFT | 1 PPT | 6 NP

02-1201
 Public Defender
 R27 PFT
 Anchorage PX

02-1226
 Attorney VI
 R26 PFT
 Anchorage PX

02-1220
 Attorney VI
 R26 PFT
 Anchorage PX

02-1298
 Attorney VI
 R26 PFT
 Anchorage PX

02-1278
 Attorney VI
 R26 PFT
 Anchorage PX

02-1378
 Program Manager
 R22 PFT
 Anchorage CL

02-1335
 Attorney V
 R25 PFT
 Dillingham PX

02-1247
 Attorney V
 R25 PFT
 Juneau PX

02-1400
 Law Office Asst II
 R13 PFT
 Anchorage CL

02-1392
 Law Office Asst II
 R13 PFT
 Anchorage CL

02-1254
 Paralegal I
 R14 PFT
 Anchorage CL

02-1396
 Assoc. Attorney I
 R17 PFT
 Anchorage PX

02-1202
 Admin Asst III
 R15 PFT
 Anchorage CL

02-1364
 Admin Officer I
 R17 PFT
 Anchorage CL

02-1329
 Attorney IV
 R24 PFT
 Anchorage PX

02-1117
 Attorney V
 R25 PFT
 Nome PX

02-1274
 Law Office Asst I
 R11 PFT
 Anchorage CL

02-1286
 Assoc. Attorney I
 R17 PFT
 Fairbanks PX

02-1244
 Law Office Asst I
 R11 PFT
 Anchorage CL

02-1297
 Law Office Asst II
 R13 PFT
 Anchorage CL

02-1232
 Acct Tech II
 R14 PFT
 Anchorage CL

02-1281
 Office Asst II
 R10 PPT
 Anchorage CL

02-1206
 Attorney V
 R25 PFT
 Fairbanks PX

02-1251
 Attorney V
 R25 PFT
 Kenai PX

02-1129
 Law Off Asst I
 R11 PFT
 Anchorage CL

02-1227
 Law Office Assist I
 R11 PFT
 Anchorage CL

02-1352
 Law Off Asst I
 R11 PFT
 Anchorage CL

02-1209
 Attorney V
 R25 PFT
 Fairbanks PX

02-1123
 Attorney V
 R25 PFT
 Palmer PX

02-1401
 Paralegal I
 R14 PFT
 Anchorage CL

02-1203
 Law Office Asst I
 R11 PFT
 Anchorage CL

02-1398
 Law Off Asst I
 R11 PFT
 Anchorage CL

02-N07035
 Law Office Assist I
 R11 NP
 Anchorage CL

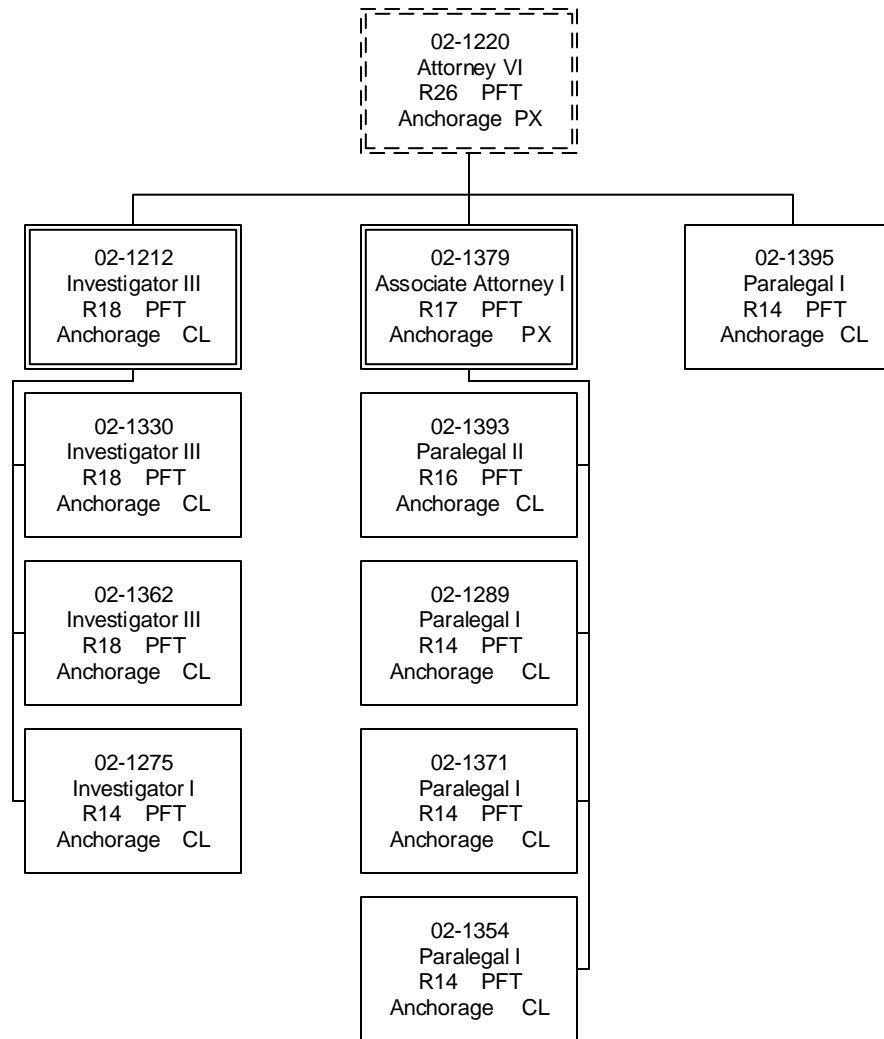

Department of Administration
 Public Defender Agency (1631)
 Anchorage Criminal Section

02-1220
 Attorney VI
 R26 PFT
 Anchorage PX

02-1342
 Attorney V
 R25 PFT
 Anchorage PX

02-1291
 Attorney IV
 R24 PFT
 Anchorage PX

02-1222
 Attorney V
 R25 PFT
 Anchorage PX

02-1161
 Attorney V
 R24 PFT
 Anchorage PX

02-1230
 Attorney V
 R25 PFT
 Anchorage PX

02-1336
 Attorney V
 R25 PFT
 Anchorage PX

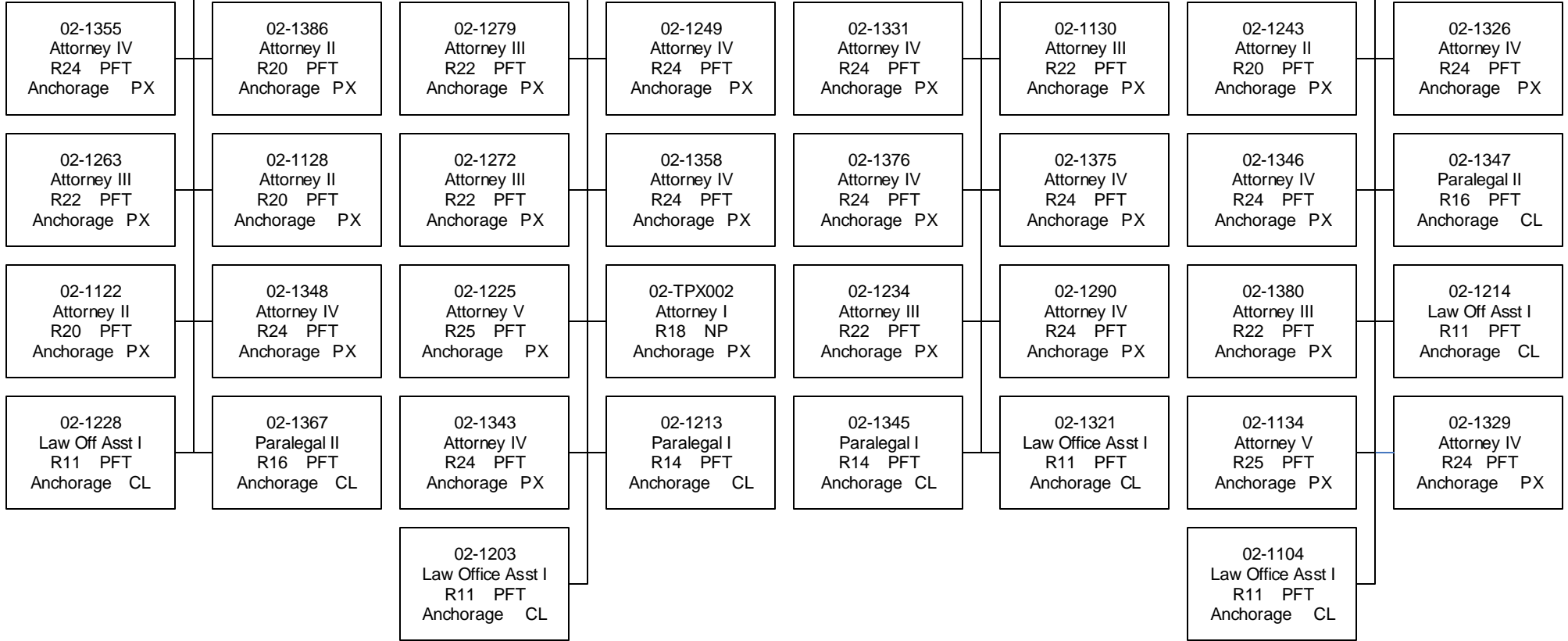

Department of Administration
Public Defender Agency (1631)
Appeals

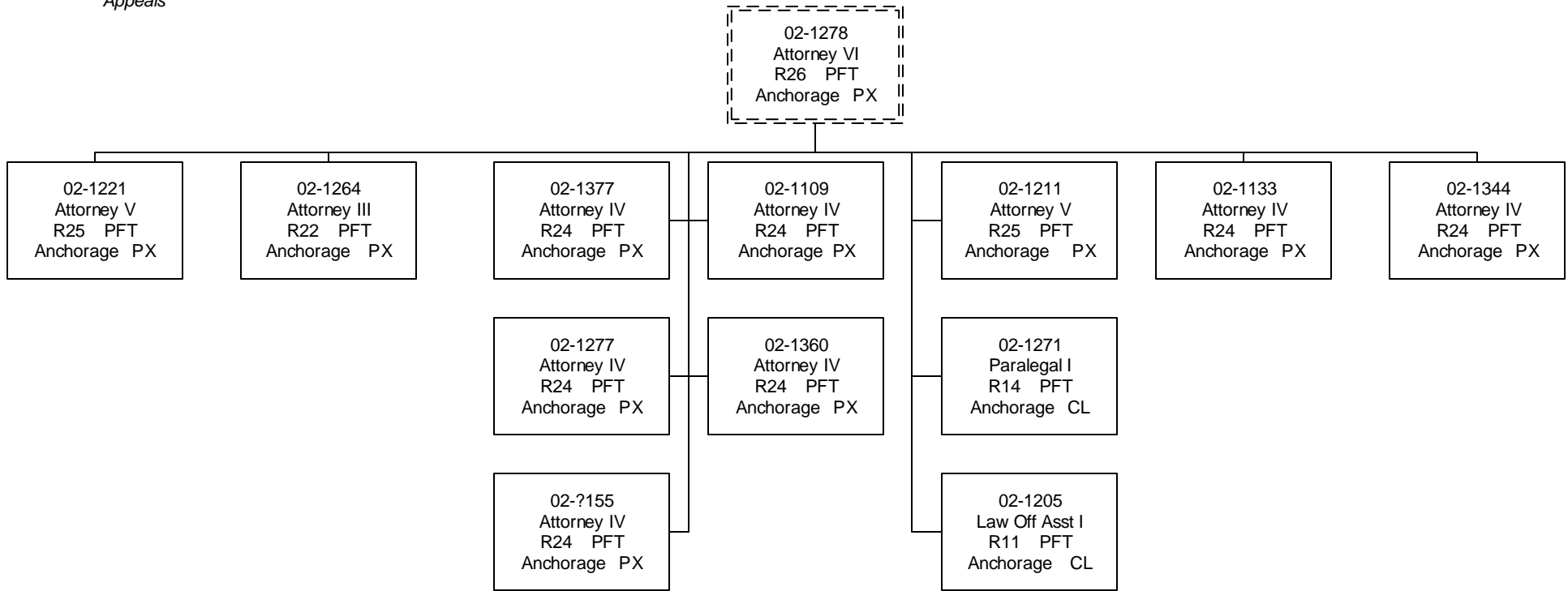

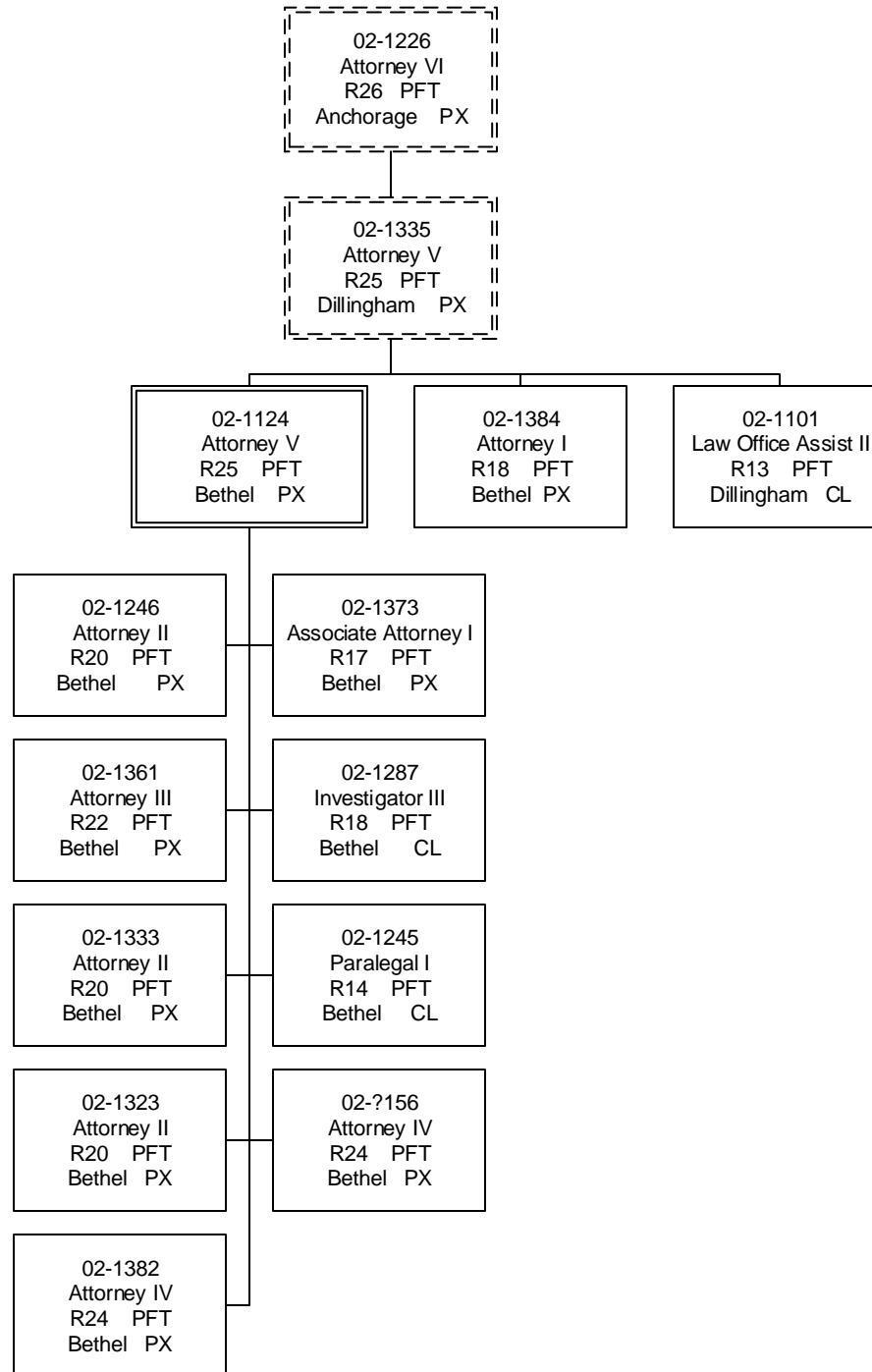

Department of Administration
Public Defender Agency (1631)
Civil Section

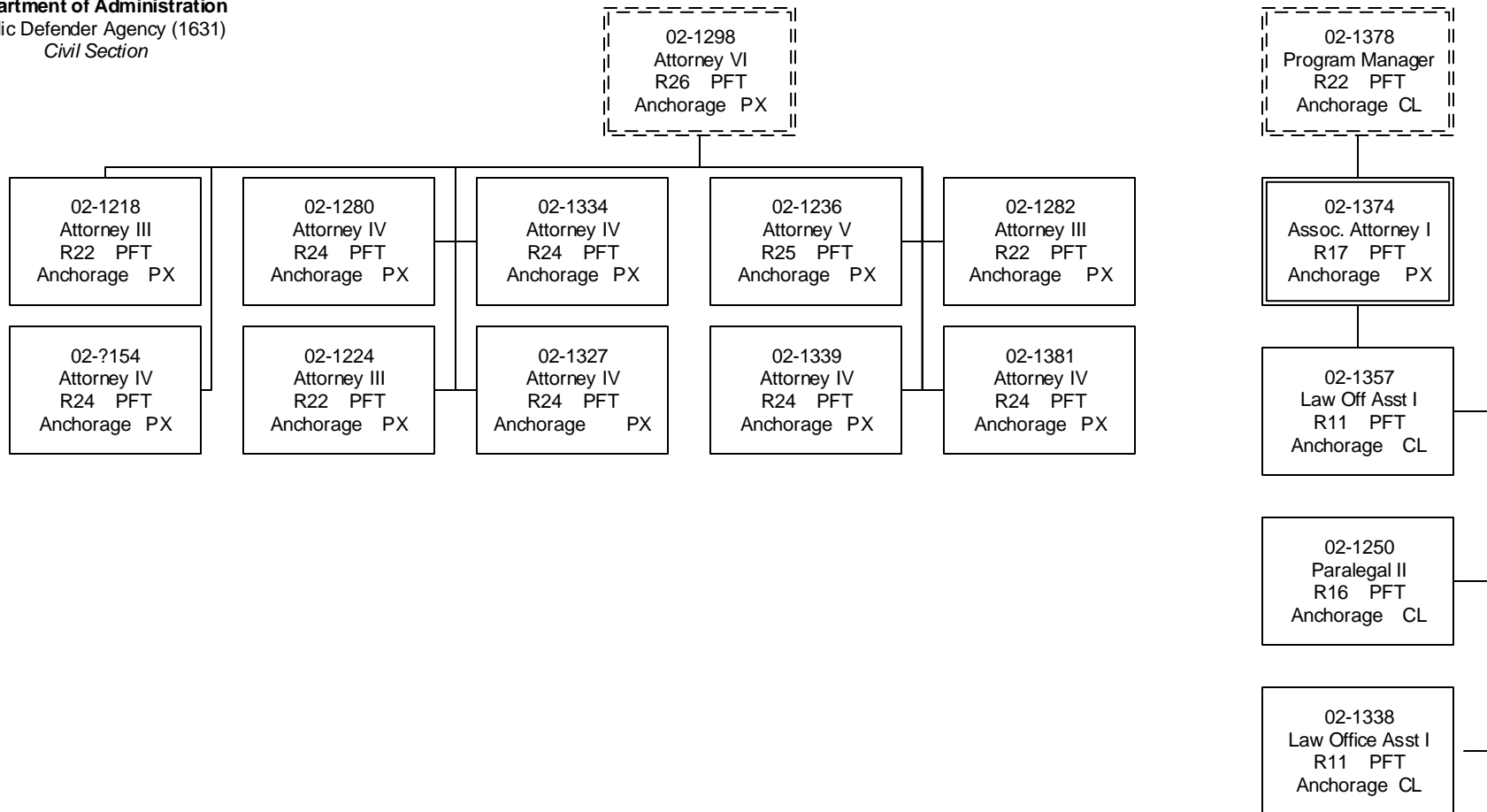

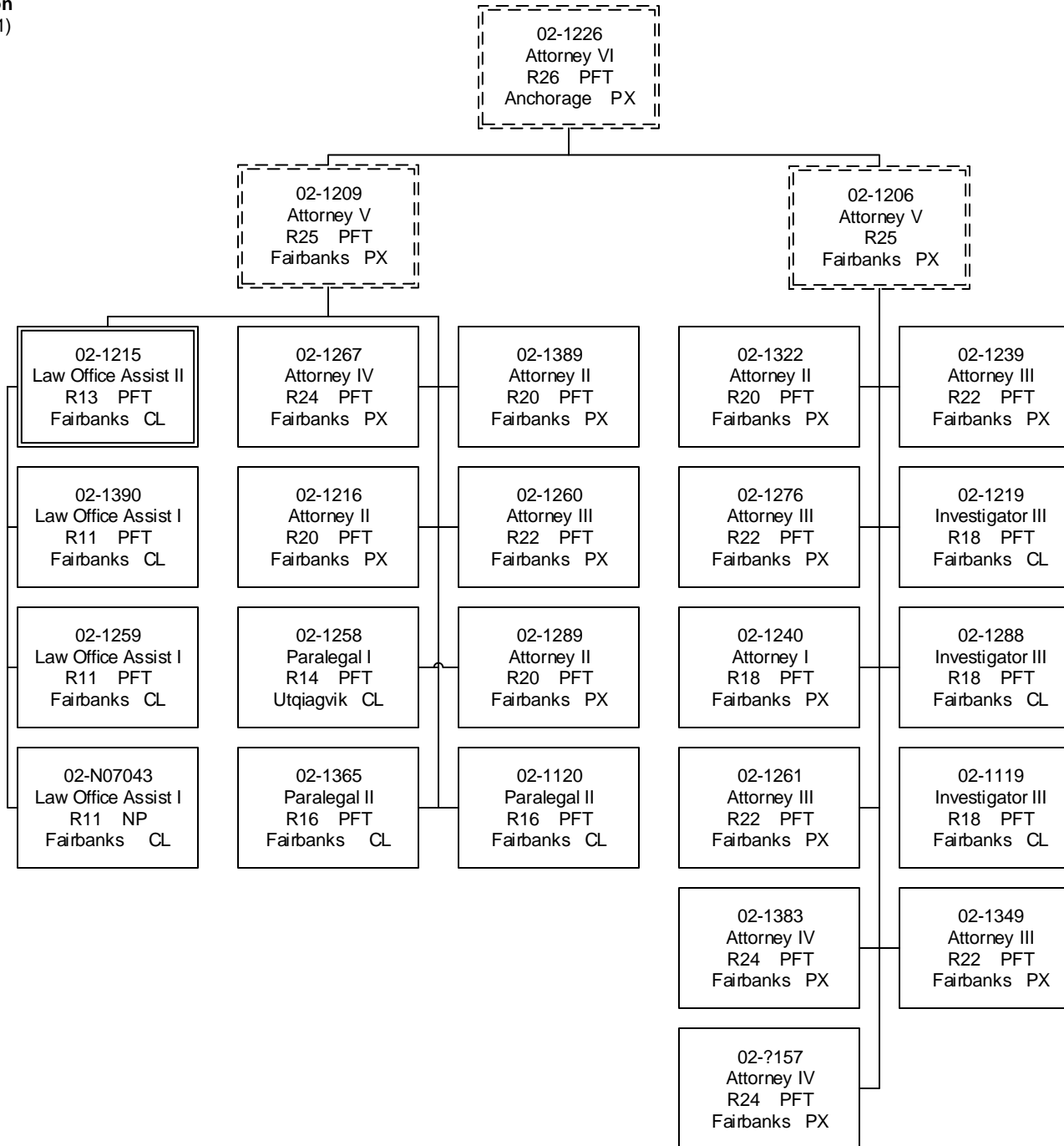

Department of Administration
Public Defender Agency (1631)
Juneau, Ketchikan & Sitka

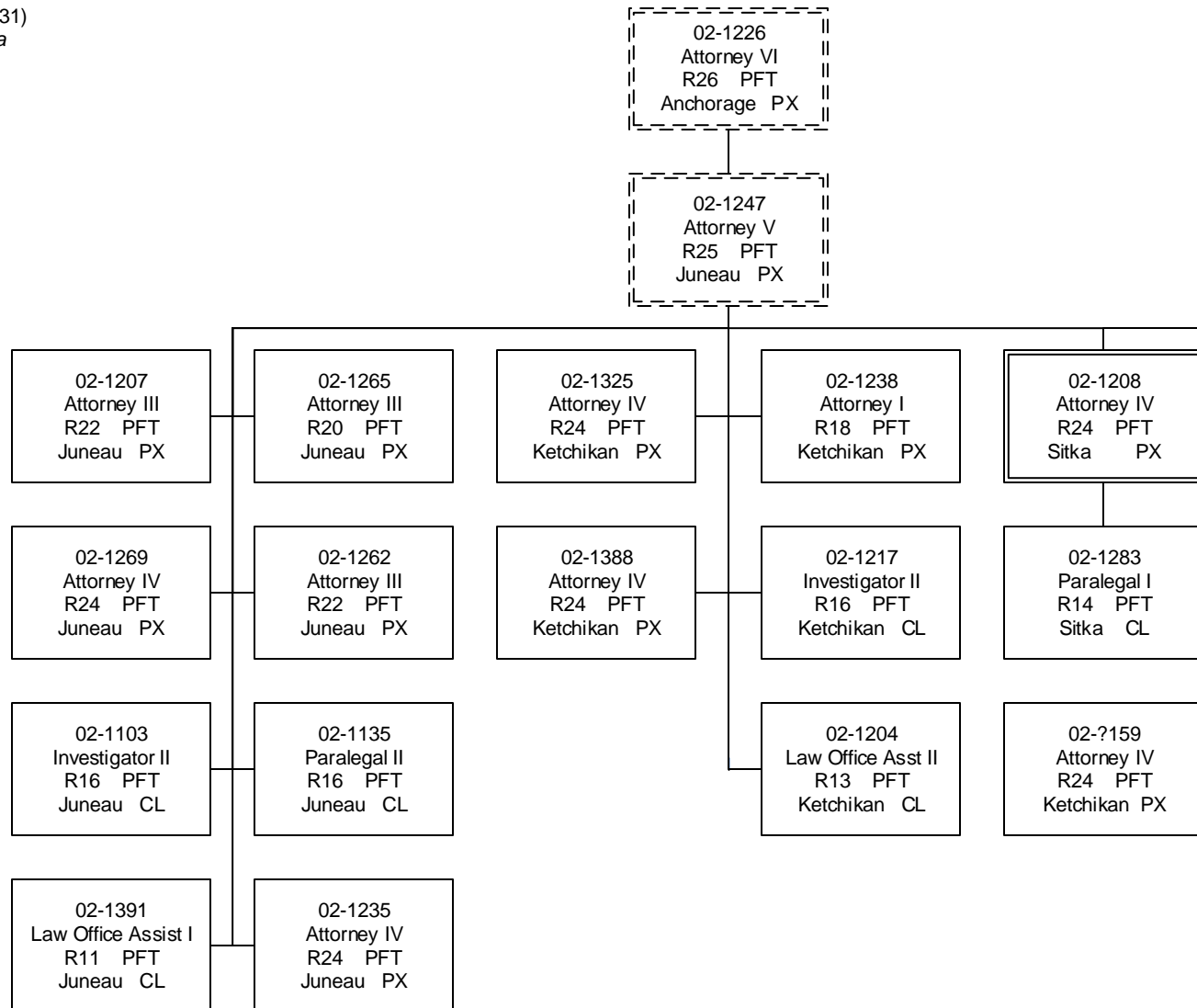

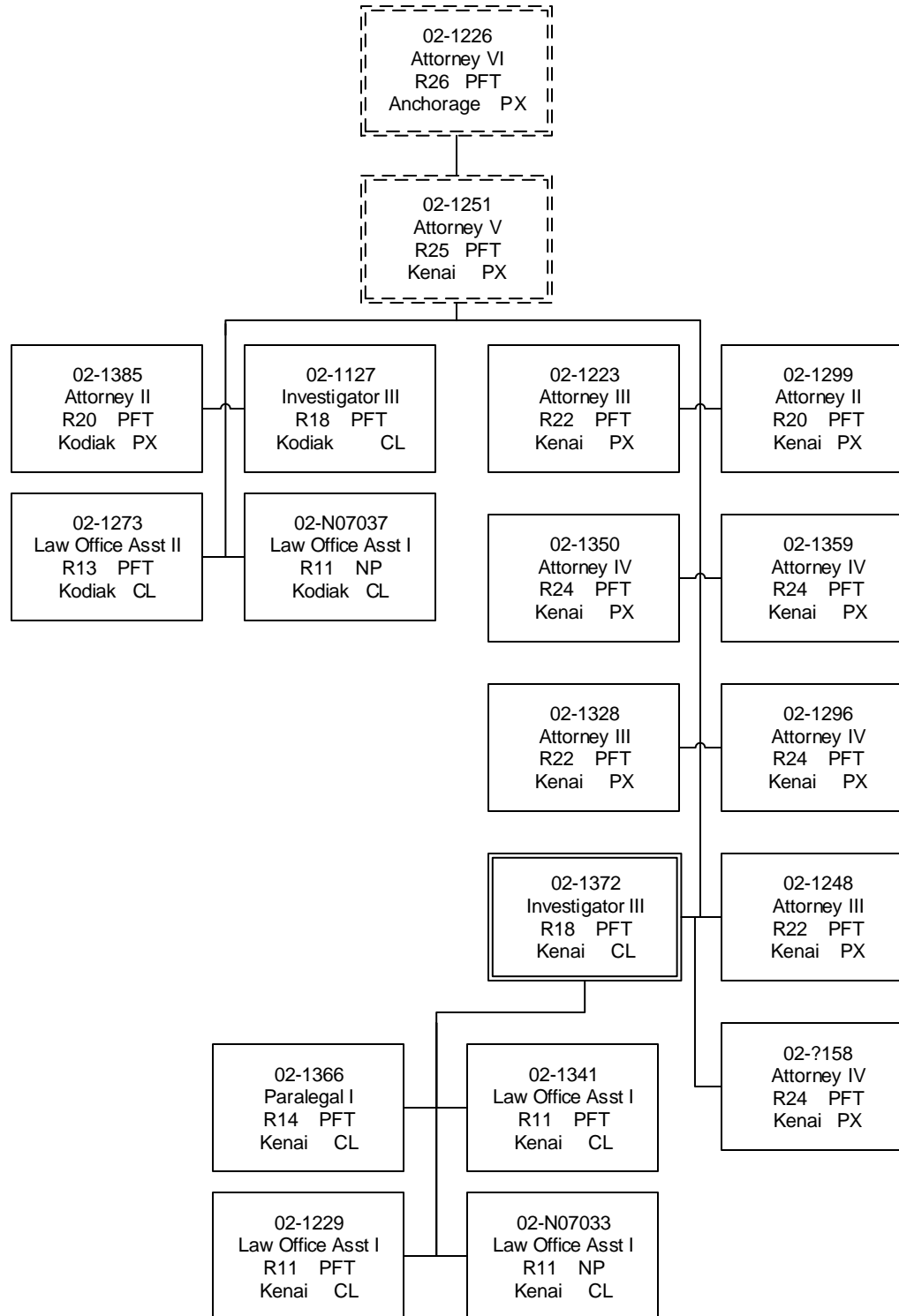

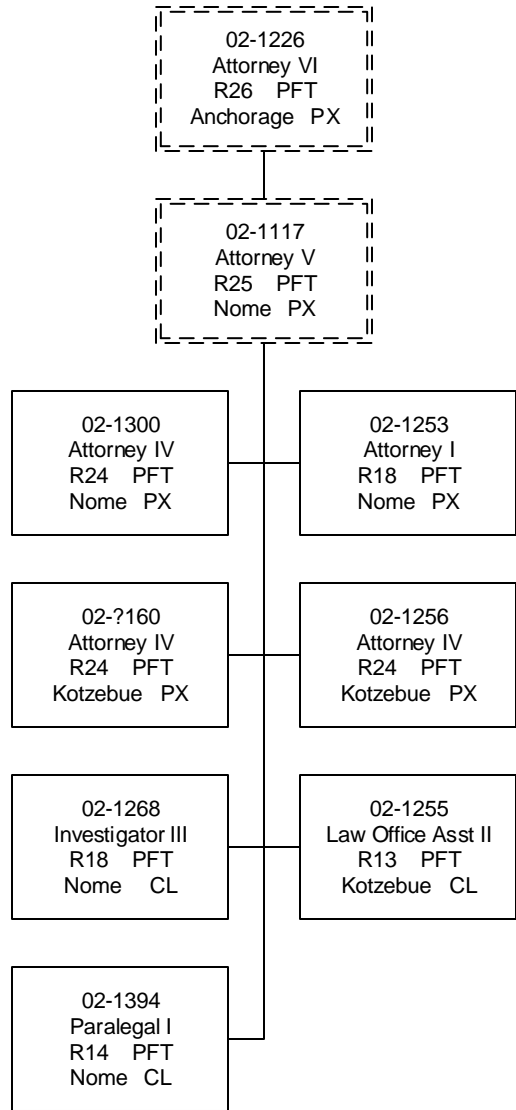

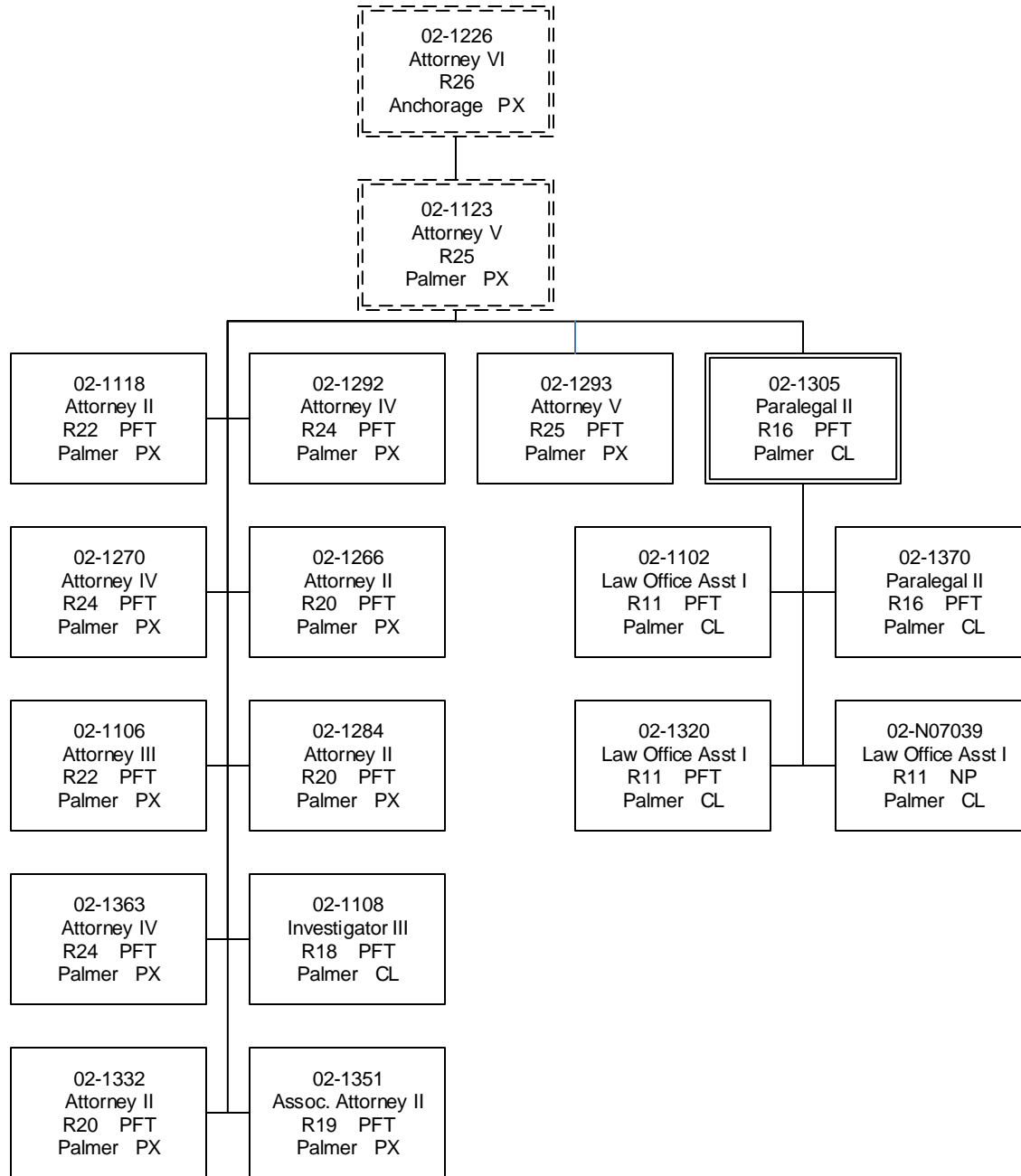

Department of Administration
Public Defender Agency (1631)
Traveling Section

