

State of Alaska
FY2023 Governor's Operating Budget

Department of Corrections
Recruitment and Retention
Component Budget Summary

Component: Recruitment and Retention**Contribution to Department's Mission**

No mission statement.

Major Component Accomplishments in 2021

Established the new Recruitment and Retention Unit (RRU) and filled two of the new positions during FY2021; an administrative officer II, an administrative assistant II, and a correctional officer IV (SSgt.) (TDY capacity). Each position was established to increase and advance recruitment methods. These positions participated and oversaw consolidated recruitment efforts for all correctional officer vacant positions.

Attended 10 recruitment and community outreach events and provided two presentations to employment agencies between March and June 2021. Each event was advertised on social media to help increase attendance. These events alone brought in an additional 43 correctional officer I applicants.

Branched out to online employment search engines to include: Corrections1/Police1.com, handshake.com, monster.com, military.com, and indeed.com.

Worked closely with media agencies to discuss the possibility of the RRU advertising on multiple platforms: radio, TV, blogs, newspapers, etc. These agencies include KYES, iHeart Radio, King Tech Highschool, as well as other local TV and radio stations.

Established weekly presentations at the Mat-Su Job center in Wasilla. These presentations have brought in about 20 applicants each week and they have made the Alaska Department of Corrections one of the leading employers utilizing the local job center.

Established weekly office hours at the Atwood building in Anchorage and the Palmer State office Building in Palmer to help applicants directly with the application process, answering questions, and notarizing/submitting documents.

Met with JBER officials to discuss recruitment methods that focus advertisements toward military personnel, veterans, and military spouses.

Attended meetings with superintendents from all facility locations to discuss and become familiar with recruitment challenges based on location.

Key Component Challenges

No key component challenges.

Significant Changes in Results to be Delivered in FY2023

No changes in results delivered.

Statutory and Regulatory Authority

No statutes and regulations.

Contact Information

Contact: Kelly Goode, Deputy Commissioner
Phone: (907) 269-7397
E-mail: kelly.goode@alaska.gov

Recruitment and Retention Personal Services Information				
Authorized Positions			Personal Services Costs	
	<u>FY2022</u> <u>Management</u> <u>Plan</u>	<u>FY2023</u> <u>Governor</u>		
Full-time	6	3	Annual Salaries	170,457
Part-time	0	0	COLA	1,107
Nonpermanent	0	0	Premium Pay	0
			Annual Benefits	123,300
			<i>Less 3.00% Vacancy Factor</i>	(8,846)
			Lump Sum Premium Pay	8,800
Totals	6	3	Total Personal Services	294,818

Position Classification Summary					
Job Class Title	Anchorage	Fairbanks	Juneau	Others	Total
Administrative Assistant 2	2	0	0	0	2
Administrative Officer 2	1	0	0	0	1
Totals	3	0	0	0	3

Component Detail All Funds
Department of Corrections

Component: Recruitment and Retention (3279)
RDU: Administration and Support (271)

Non-Formula Component

	FY2021 Actuals	FY2022 Conference Committee	FY2022 Authorized	FY2022 Management Plan	FY2023 Governor	FY2022 Management Plan vs FY2023 Governor	
71000 Personal Services	409.1	506.2	506.2	661.2	0.0	-661.2	-100.0%
72000 Travel	0.0	0.0	0.0	0.0	0.0	0.0	0.0%
73000 Services	91.3	260.0	260.0	260.0	0.0	-260.0	-100.0%
74000 Commodities	46.5	0.0	0.0	0.0	0.0	0.0	0.0%
75000 Capital Outlay	0.0	0.0	0.0	0.0	0.0	0.0	0.0%
77000 Grants, Benefits	0.0	0.0	0.0	0.0	0.0	0.0	0.0%
78000 Miscellaneous	0.0	0.0	0.0	0.0	0.0	0.0	0.0%
Totals	546.9	766.2	766.2	921.2	0.0	-921.2	-100.0%
Fund Sources:							
1004 Gen Fund (UGF)	546.9	766.2	766.2	921.2	0.0	-921.2	-100.0%
Unrestricted General (UGF)	546.9	766.2	766.2	921.2	0.0	-921.2	-100.0%
Designated General (DGF)	0.0	0.0	0.0	0.0	0.0	0.0	0.0%
Other Funds	0.0	0.0	0.0	0.0	0.0	0.0	0.0%
Federal Funds	0.0	0.0	0.0	0.0	0.0	0.0	0.0%
Positions:							
Permanent Full Time	5	5	5	6	0	-6	-100.0%
Permanent Part Time	0	0	0	0	0	0	0.0%
Non Permanent	0	0	0	0	0	0	0.0%

Component Detail All Funds
Department of Corrections

Component: Recruitment and Retention (3279)
RDU: Population Management (550)

Non-Formula Component

	FY2021 Actuals	FY2022 Conference Committee	FY2022 Authorized	FY2022 Management Plan	FY2023 Governor	FY2022 Management Plan vs FY2023 Governor
71000 Personal Services	0.0	0.0	0.0	0.0	294.8	294.8 100.0%
72000 Travel	0.0	0.0	0.0	0.0	0.0	0.0 0.0%
73000 Services	0.0	0.0	0.0	0.0	105.2	105.2 100.0%
74000 Commodities	0.0	0.0	0.0	0.0	0.0	0.0 0.0%
75000 Capital Outlay	0.0	0.0	0.0	0.0	0.0	0.0 0.0%
77000 Grants, Benefits	0.0	0.0	0.0	0.0	0.0	0.0 0.0%
78000 Miscellaneous	0.0	0.0	0.0	0.0	0.0	0.0 0.0%
Totals	0.0	0.0	0.0	0.0	400.0	400.0 100.0%
Fund Sources:						
1004 Gen Fund (UGF)	0.0	0.0	0.0	0.0	400.0	400.0 100.0%
Unrestricted General (UGF)	0.0	0.0	0.0	0.0	400.0	400.0 100.0%
Designated General (DGF)	0.0	0.0	0.0	0.0	0.0	0.0 0.0%
Other Funds	0.0	0.0	0.0	0.0	0.0	0.0 0.0%
Federal Funds	0.0	0.0	0.0	0.0	0.0	0.0 0.0%
Positions:						
Permanent Full Time	0	0	0	0	3	3 100.0%
Permanent Part Time	0	0	0	0	0	0 0.0%
Non Permanent	0	0	0	0	0	0 0.0%

Change Record Detail - Multiple Scenarios with Descriptions
Department of Corrections

Component: Recruitment and Retention (3279)

RDU: Population Management (550)

Scenario/Change Record Title	Trans Type	Totals	Personal Services	Travel	Services	Commodities	Capital Outlay	Grants, Benefits	Miscellaneous	Positions		NP
										PFT	PPT	
***** Changes From FY2022 Conference Committee To FY2022 Authorized *****												
FY2022 Conference Committee												
1004 Gen Fund	ConfCom	766.2	506.2	0.0	260.0	0.0	0.0	0.0	0.0	5	0	0
		766.2										
	Subtotal	766.2	506.2	0.0	260.0	0.0	0.0	0.0	0.0	5	0	0
***** Changes From FY2022 Authorized To FY2022 Management Plan *****												
Transfer Human Resource Consultant 2 (07-1605) from Administrative Services for Staffing Support												
1004 Gen Fund	Trin	155.0	155.0	0.0	0.0	0.0	0.0	0.0	0.0	1	0	0
		155.0										
	Subtotal	921.2	661.2	0.0	260.0	0.0	0.0	0.0	0.0	6	0	0
***** Changes From FY2022 Management Plan To FY2023 Governor *****												
FY2023 Salary and Benefit Adjustments												
1004 Gen Fund	SalAdj	1.1	1.1	0.0	0.0	0.0	0.0	0.0	0.0	0	0	0
		1.1										
Includes: FY2023 Supervisory Unit 1% COLA: \$1.1												
FY2023 Supervisory Employees Health Insurance, SBS, and Risk Management Rate Changes												
1004 Gen Fund	SalAdj	0.5	0.5	0.0	0.0	0.0	0.0	0.0	0.0	0	0	0
		0.5										
FY2023 Change Supervisory Employees (SS) - Health Insurance from \$1,555 to \$1,685; SBS and Risk Management Rates: \$0.5												
FY2023 Confidential Employees Association Health Insurance, SBS, and Risk Management Rate Changes												
1004 Gen Fund	SalAdj	1.6	1.6	0.0	0.0	0.0	0.0	0.0	0.0	0	0	0
		1.6										
FY2023 Change Confidential Employees Association CEA (KK) - Health Insurance from \$1,555 to \$1,685 per member; SBS, and Risk Management Rates: \$1.6												
FY2023 General Government Unit SBS and Risk Management Rate Changes												
1004 Gen Fund	SalAdj	-1.2	-1.2	0.0	0.0	0.0	0.0	0.0	0.0	0	0	0
		-1.2										
FY2023 Change General Government Unit (GG, GP, GY, GZ) - SBS, and Risk Management Rates: \$-1.2												

Change Record Detail - Multiple Scenarios with Descriptions
Department of Corrections

Component: Recruitment and Retention (3279)

RDU: Population Management (550)

Scenario/Change Record Title	Trans Type	Totals	Personal Services	Travel	Services	Commodities	Capital Outlay	Grants, Benefits	Miscellaneous	Positions		
										PFT	PPT	NP
FY2023 PERS Actuarial Rate Adjustment to 24.79% Ch9 SLA2021 (SB55)												
	SalAdj	-20.6	-20.6	0.0	0.0	0.0	0.0	0.0	0.0	0	0	0
1004 Gen Fund		-20.6										
Includes: FY2023 Adjustment for PERS ARM Board Approved Rate of 24.79% (from 30.11%): \$-20.6												
Transfer Human Resource Consultants and Tech (07-1605, 20-1013, 20-6002) to Administrative Services for Staffing Support												
	Trout	-502.6	-347.8	0.0	-154.8	0.0	0.0	0.0	0.0	-3	0	0
1004 Gen Fund		-502.6										
Transfer Human Resource Consultant 2 (07-1605), range 18, located in Anchorage, Human Resource Consultant 1 (20-1013), range 16, located in Juneau, and Human Resource Technician 1 (20-6002), range 12, located in Juneau to Administrative Services. These positions oversee and support all probation and correctional officer Alaska Police Standards Council requirements. This returns these positions to Administrative Services and allows the centralized Recruitment and Retention Unit to focus all efforts on correctional officer recruitment activities such as (but not limited to); job fairs, interviews, and applicant outreach.												
Recruitment and Retention Allocation Move to Population Management												
	Misadj	0.0	0.0	0.0	0.0	0.0	0.0	0.0	0.0	0	0	0
The new Recruitment and Retention component was established during the SLA2020 legislative session under Administration and Support and included \$450.0 UGF and three positions. Transferring the component into Population Management will allow the Department to hire correctional officers as part of their assigned duties and will provide that front line knowledge and experience to new recruits and potential future applicants.												
Totals		400.0	294.8	0.0	105.2	0.0	0.0	0.0	0.0	3	0	0

Line Item Detail (1676)
Department of Corrections
Services

Component: Recruitment and Retention (3279)

Line Number	Line Name		FY2021 Actuals	FY2022 Management Plan	FY2023 Governor
3000	Services		91.3	260.0	105.2
Object Class	Servicing Agency	Explanation	FY2021 Actuals	FY2022 Management Plan	FY2023 Governor
3000 Services Detail Totals			91.3	260.0	105.2
3000	Education Services	Professional service costs related to conference registration fees, training, membership dues and other miscellaneous services.	0.0	2.5	2.5
3003	Information Technology	Professional service costs related to computer consultant fees, outsource contracts, software licensing, software maintenance, conference registration fees, training, and membership dues to professional organizations.	0.0	15.0	5.0
3004	Telecommunications	Local and long distance telephone services and other related miscellaneous communication charges.	0.6	3.5	3.5
3005	Health Services	New employee physical reimbursements.	25.3	0.0	0.0
3006	Delivery Services	Freight costs, delivery and express services, postage, messenger services, etc.	0.0	1.5	1.5
3007	Advertising and Promotions	Recruitment advertising and promotions for correctional officer vacancies.	33.3	0.0	0.0
3009	Structure/Infrastructure/Land	Room and office leases, inspections, janitorial services, snow removal, other repairs and maintenance.	15.9	10.0	10.0
3010	Equipment/Machinery	Minor repairs and rentals of office equipment not covered by	0.0	23.0	11.6

Line Item Detail (1676)
Department of Corrections
Services

Component: Recruitment and Retention (3279)

Object Class	Servicing Agency	Explanation	FY2021 Actuals	FY2022 Management Plan	FY2023 Governor
3000 Services Detail Totals			91.3	260.0	105.2
3011	Other Services	maintenance or lease agreements. Other professional services for grants and contracts, e.g., reentry services/support, construction consulting services, recruitment outreach, recruitment advertising, marketing materials, training, medical testing reimbursements, safety, graphics.	0.0	134.6	0.0
3017	Inter-Agency Information Technology Non-Telecommunications	Admin - Department-wide Office of Information Technology (OIT) Core Services, OIT Server Hosting & Storage, OIT Licenses for Adobe, Microsoft and SQL rates charges.	13.6	9.7	10.0
3018	Inter-Agency Information Technology Telecommunications	Admin - Department-wide Office of Information Technology (OIT) Telephone charges.	0.0	15.0	15.0
3022	Inter-Agency Human Resources	Admin - Department-wide Human Resource service charges.	2.4	4.6	5.0
3023	Inter-Agency Building Leases	Admin - Department-wide Office lease space charges.	0.0	20.0	20.0
3027	Inter-Agency Financial	Admin - Department-wide Integrated Resource Information System (IRIS) Financial, IRIS Human Resource Management (HRM)/Payroll, Alaska Data Enterprise Reporting (ALDER) charges and Shared Services of Alaska (SSoA) chargeback.	0.2	0.5	0.2
3028	Inter-Agency Americans with Disabilities Act Compliance	Admin - Department-wide Americans with Disabilities Act (ADA) compliance charges.	0.0	0.1	0.1
3029	Inter-Agency Education/Training	Admin - Department-wide Certification and Training charges.	0.0	5.0	5.8
3037	State Equipment Fleet	Trans - Department-wide State Equipment Fleet (SEF) charges.	0.0	15.0	15.0

Line Item Detail (1676)
Department of Corrections
Commodities

Component: Recruitment and Retention (3279)

Line Number	Line Name		FY2021 Actuals	FY2022 Management Plan	FY2023 Governor
4000	Commodities		46.5	0.0	0.0
Object Class	Servicing Agency	Explanation	FY2021 Actuals	FY2022 Management Plan	FY2023 Governor
4000 Commodities Detail Totals			46.5	0.0	0.0
4000	Business	Consumable office supplies, duplicating, data processing supplies; i.e., paper forms, printer and toner cartridges, and other related supplies.	36.0	0.0	0.0
4002	Household/Institutional	Supplies and other miscellaneous expenses.	10.5	0.0	0.0

Inter-Agency Services (1682)
Department of Corrections

Component: Recruitment and Retention (3279)

				FY2021 Actuals	FY2022 Management Plan	FY2023 Governor
Component Totals				16.2	69.9	71.1
With Department of Administration				16.2	54.9	56.1
With Department of Transportation/Public Facilities				0.0	15.0	15.0
Object Class	Servicing Agency	Explanation	FY2021 Actuals	FY2022 Management Plan	FY2023 Governor	
3017	Inter-Agency Information Technology Non-Telecommunications	Admin - Department-wide Office of Information Technology (OIT) Core Services, OIT Server Hosting & Storage, OIT Licenses for Adobe, Microsoft and SQL rates charges.	13.6	9.7	10.0	
3018	Inter-Agency Information Technology Telecommunications	Admin - Department-wide Office of Information Technology (OIT) Telephone charges.	0.0	15.0	15.0	
3022	Inter-Agency Human Resources	Admin - Department-wide Human Resource service charges.	2.4	4.6	5.0	
3023	Inter-Agency Building Leases	Admin - Department-wide Office lease space charges.	0.0	20.0	20.0	
3027	Inter-Agency Financial	Admin - Department-wide Integrated Resource Information System (IRIS) Financial, IRIS Human Resource Management (HRM)/Payroll, Alaska Data Enterprise Reporting (ALDER) charges and Shared Services of Alaska (SSoA) chargeback.	0.2	0.5	0.2	
3028	Inter-Agency Americans with Disabilities Act Compliance	Admin - Department-wide Americans with Disabilities Act (ADA) compliance charges.	0.0	0.1	0.1	
3029	Inter-Agency Education/Training	Admin - Department-wide Certification and Training charges.	0.0	5.0	5.8	
3037	State Equipment Fleet	Trans - Department-wide State Equipment Fleet (SEF) charges.	0.0	15.0	15.0	

Personal Services Expenditure Detail
Department of Corrections

Scenario: FY2023 Governor (18673)
Component: Recruitment and Retention (3279)
RDU: Population Management (550)

PCN	Job Class Title	Time Status	Retire Code	Barg Unit	Location	Salary Sched	Range / Step	Comp Months	Split / Count	Annual Salaries	COLA	Premium Pay	Annual Benefits	Total Costs	UGF Amount
20-1090	Administrative Assistant 2	FT	A	GP	Anchorage	200	14B	11.0		43,168	0	0	34,164	77,332	77,332
20-1091	Administrative Assistant 2	FT	A	GP	Anchorage	200	14B / C	12.0		47,803	0	0	37,549	85,352	85,352
20-1092	Administrative Officer 2	FT	A	SS	Anchorage	200	19D / E	12.0		79,486	1,107	0	51,587	132,180	132,180
Total													Total Salary Costs:	170,457	
Positions													Total COLA:	1,107	
Full Time Positions:													Total Premium Pay:	0	
Part Time Positions:													Total Benefits:	123,300	
Non Permanent Positions:															
Positions in Component:													Total Pre-Vacancy:	294,864	
													Minus Vacancy Adjustment of 3.00%:	(8,846)	
													Total Post-Vacancy:	286,018	
													Plus Lump Sum Premium Pay:	8,800	
													Personal Services Line 100:	294,818	
Total Component Months:		35.0													

PCN Funding Sources:	Pre-Vacancy	Post-Vacancy	Percent
1004 General Fund Receipts	294,864	286,018	100.00%
Total PCN Funding:	294,864	286,018	100.00%

Lump Sum Funding Sources:	Amount	Percent
1004 General Fund Receipts	8,800	100.00%
Total Lump Sum Funding:	8,800	100.00%

Note: If a position is split, an asterisk (*) will appear in the Split/Count column. If the split position is also counted in the component, two asterisks (**) will appear in this column. [No valid job title] appearing in the Job Class Title indicates that the PCN has an invalid class code or invalid range for the class code effective date of this scenario.

Department of Corrections
Recruitment and Retention
FY 2023 Organizational Structure

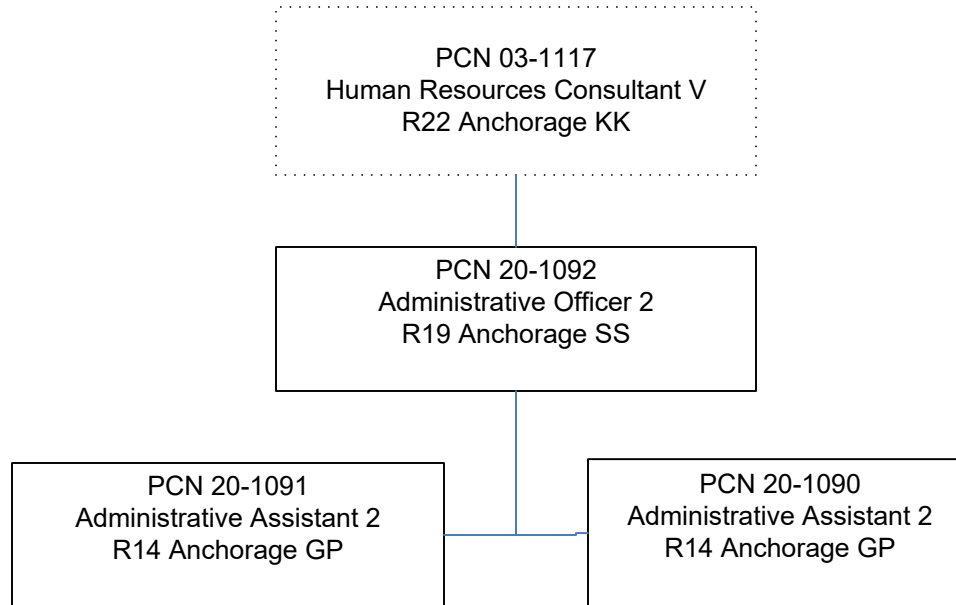

Note: Boxes with dotted lines are budgeted within a separate component.