

State of Alaska FY2023 Governor's Operating Budget

Department of Labor and Workforce Development Alaska Vocational Technical Center Component Budget Summary

Component: Alaska Vocational Technical Center

Contribution to Department's Mission

Expand employment opportunities for Alaskans by preparing students with career and technical skills required for success in the Alaska workplace.

Core Services

- Provide post-secondary career and technical training to Alaskans.
- Offer training programs to Alaskans that provide for learning technical and employability skills to prepare students for employment, additional education or apprenticeships upon successful completion of training.
- Offer customized and specific training for incumbent workers to increase upward mobility in their current position, and continuing education for incumbent workers to maintain employment.
- Facilitate AVTEC graduates connecting with employers within one year of completion of their training to obtain employment.

Major Component Accomplishments in 2021

- AVTEC is an accredited postsecondary technical and vocational training school through the Council on Occupational Education (COE) a national accreditation council. As an accredited school, AVTEC is bound to follow quality standards and evaluates performance based on those standards for continued accreditation. Of note, the standard for student placement into employment in their field of study is 70% and AVTEC exceeded that standard in FY2020 with a placement rate of 82%, slightly down from the previous year but well above the national standard. (Placement data lags by one year and is available each July of the following year of completion.)
- Despite the pandemic, in FY2020, 94 percent of students graduated from training programs at AVTEC; the employment rate lags one year so the FY2020 reported employment rate of 82 percent is accurate and in the FY2021 rate will be reported in FY22; both will be down from historical rates due to the pandemic enrollment numbers restrictions at AVTEC.
- Partnered with the University of Alaska to create an education consortium, the Alaska Maritime Education Consortium (AMEC) and developed an action agenda that outlines a collaborative process for delivering maritime training across Alaska. The AMEC submitted an application to the Maritime Administration (MARAD) for status as a Domestic Maritime Center of Excellence and on May 19, 2021, and was formally designated a Domestic Maritime Center of Excellence for 2021. Alaska has one of two consortiums designated and are one of twenty-seven DMCOE designated schools nationwide.
- Continued to fulfill the mission and core services throughout the pandemic over the past 18 months; in FY2021 AVTEC was open and operational with staff and instructors to provide face to face training at 50 percent capacity.
- Prepared for reaffirmation of accreditation through a self-study reflection of all operations and instructional programming and wrote a 200 page self-study report in preparation for the 6 year reaffirmation review.

Key Component Challenges

AVTEC experienced a 25 percent staff turnover rate during FY2021 and due to this turnover a staffing shortage was experienced. The challenge has been to continue to provide quality programming and services at this vacancy level and to fill these positions with skilled employees and subject matter experts in instructional roles.

AVTEC was poised to expand access to training for Alaskans across the state by delivering short term courses and partnerships with local community providers and then the pandemic hit, and travel restrictions were put into place and in-person instruction was not an option. A pivot to online training to respond was only marginally

successful for the following reasons:

- The type of hands on training offered at AVTEC does not lend itself well to online learning,
- Our student population are from rural communities with limited broadband access
- Instructional staff have little to no experience teaching in an online format and there was no time to train them for that pivot.

AVTEC has chosen to return to full capacity in-person instruction, which brings different challenges of a health and safety nature.

AVTEC continues to be challenged to balance the annual maintenance and operations of AVTEC's facilities with unplanned emergency repair work required to address immediate health and safety issues.

Significant Changes in Results to be Delivered in FY2023

- AVTEC will expand apprenticeship services and become a multi-employer sponsor, resulting in an increasingly diverse offering of related technical instruction.
- A streamlined organizational chart, in support of the updated strategic plan, will accommodate subject matter expertise in postsecondary program delivery, operational activities, and specific industry training; this new design will position AVTEC for the future and compartmentalize the key roles and responsibilities of the staff and administration while providing overlap on strategy for organizational success.
- Increase user fees for AVTEC services including but not limited to online related technical instruction, customized training (including use of the maritime simulators), and student consumables.

Statutory and Regulatory Authority

Statutory Authority:

AS 44.31.020(7)	Administer Alaska Vocational Technical Education Programs
AS 37.07.020(e)	Propose Budget for Facility Operations, Maintenance, Repairs, and Renewals/Replacements
AS 23.15.835	Alaska Technical and Vocational Education Program Account

Administrative Regulations:

8 AAC 82.100	Tuition and Fee Rates
--------------	-----------------------

Contact Information
Contact: Cathy LeCompte, Director Phone: (907) 224-6150 E-mail: cathy.lecompte@avtec.edu

Alaska Vocational Technical Center Personal Services Information				
Authorized Positions			Personal Services Costs	
	FY2022 Management Plan	FY2023 Governor		
Full-time	55	55	Annual Salaries	4,813,108
Part-time	14	14	COLA	6,457
Nonpermanent	4	4	Premium Pay	37,458
			Annual Benefits	2,993,318
			<i>Less 5.58% Vacancy Factor</i>	<i>(438,241)</i>
			Lump Sum Premium Pay	0
Totals	73	73	Total Personal Services	7,412,100

Position Classification Summary					
Job Class Title	Anchorage	Fairbanks	Juneau	Others	Total
Accountant 4	0	0	0	1	1
Accounting Technician 2	0	0	0	1	1
Accounting Technician 3	0	0	0	2	2
Administrative Officer 1	0	0	0	1	1
AVTEC Instructor	0	0	0	28	28
Data Processing Manager 1	0	0	0	1	1
Division Director - Px	0	0	0	1	1
Division Operations Manager	0	0	0	1	1
Dormitory Attendant	0	0	0	4	4
Education Associate 3	0	0	0	2	2
Education Program Assistant	0	0	0	6	6
Food Service, Foreman	0	0	0	1	1
Food Service, Journey	0	0	0	2	2
Food Service, Lead	0	0	0	1	1
Food Service, Sub-Journey	0	0	0	5	5
Grants Administrator 2	0	0	0	1	1
Instructors Aide 2	0	0	0	1	1
Internet Specialist 1	0	0	0	1	1
Micro/Net Sp 1	0	0	0	2	2
Office Assistant 3	0	0	0	1	1
Procurement Specialist 1	0	0	0	1	1
Program Coordinator 1	0	0	0	1	1
Publications Specialist 1	0	0	0	1	1
Recreation Assistant	0	0	0	1	1
Student Intern 1	0	0	0	1	1
Student Worker	0	0	0	1	1
Sub Teacher - AVTEC	0	0	0	1	1
Teacher - AVTEC	0	0	0	3	3
Totals	0	0	0	73	73

Component Detail All Funds
Department of Labor and Workforce Development

Component: Alaska Vocational Technical Center (2686)
RDU: Alaska Vocational Technical Center (578)

Non-Formula Component

	FY2021 Actuals	FY2022 Conference Committee	FY2022 Authorized	FY2022 Management Plan	FY2023 Governor	FY2022 Management Plan vs FY2023 Governor	
71000 Personal Services	6,789.1	7,770.4	7,770.4	7,560.1	7,412.1	-148.0	-2.0%
72000 Travel	7.6	45.2	45.2	45.2	45.2	0.0	0.0%
73000 Services	3,188.9	3,670.1	3,508.3	3,508.3	3,286.3	-222.0	-6.3%
74000 Commodities	569.7	1,011.3	1,231.8	1,442.1	971.6	-470.5	-32.6%
75000 Capital Outlay	217.9	194.0	194.0	194.0	194.0	0.0	0.0%
77000 Grants, Benefits	648.3	1,215.7	1,215.7	1,215.7	1,215.7	0.0	0.0%
78000 Miscellaneous	0.0	0.0	0.0	0.0	0.0	0.0	0.0%
Totals	11,421.5	13,906.7	13,965.4	13,965.4	13,124.9	-840.5	-6.0%
Fund Sources:							
1002 Fed Rcpts (Fed)	617.8	815.3	815.3	815.3	815.3	0.0	0.0%
1004 Gen Fund (UGF)	4,361.2	4,710.1	4,710.1	4,710.1	4,605.3	-104.8	-2.2%
1005 GF/Prgm (DGF)	1,691.3	3,785.5	3,785.5	3,785.5	3,516.8	-268.7	-7.1%
1007 I/A Rcpts (Other)	1,022.8	1,078.3	1,078.3	1,078.3	1,062.9	-15.4	-1.4%
1108 Stat Desig (Other)	803.5	1,165.8	1,165.8	1,165.8	1,155.2	-10.6	-0.9%
1151 VoTech Ed (DGF)	2,174.9	2,351.7	1,969.4	1,969.4	1,969.4	0.0	0.0%
1213 AHCC Rcpts (UGF)	750.0	0.0	0.0	0.0	0.0	0.0	0.0%
1265 COVID Fed (Fed)	0.0	0.0	441.0	441.0	0.0	-441.0	-100.0%
Unrestricted General (UGF)	5,111.2	4,710.1	4,710.1	4,710.1	4,605.3	-104.8	-2.2%
Designated General (DGF)	3,866.2	6,137.2	5,754.9	5,754.9	5,486.2	-268.7	-4.7%
Other Funds	1,826.3	2,244.1	2,244.1	2,244.1	2,218.1	-26.0	-1.2%
Federal Funds	617.8	815.3	1,256.3	1,256.3	815.3	-441.0	-35.1%
Positions:							
Permanent Full Time	53	53	53	55	55	0	0.0%
Permanent Part Time	13	13	13	14	14	0	0.0%
Non Permanent	4	4	4	4	4	0	0.0%

Change Record Detail - Multiple Scenarios with Descriptions
Department of Labor and Workforce Development

Component: Alaska Vocational Technical Center (2686)

RDU: Alaska Vocational Technical Center (578)

Scenario/Change Record Title	Trans Type	Totals	Personal Services	Travel	Services	Commodities	Capital Outlay	Grants, Benefits	Miscellaneous	Positions		NP
										PFT	PPT	
***** Changes From FY2022 Conference Committee To FY2022 Authorized *****												
FY2022 Conference Committee												
	ConfCom	13,906.7	7,770.4	45.2	3,670.1	1,011.3	194.0	1,215.7	0.0	53	13	4
1002 Fed Rcpts		815.3										
1004 Gen Fund		4,710.1										
1005 GF/Prgm		3,785.5										
1007 I/A Rcpts		1,078.3										
1108 Stat Desig		1,165.8										
1151 VoTech Ed		2,351.7										
American Rescue Plan Receipts Sec 19 SLA2021 P117 L7 (HB69) (FY21-FY24)												
	CarryFwd	441.0	0.0	0.0	220.5	220.5	0.0	0.0	0.0	0	0	0
1265 COVID Fed		441.0										
Carry forward the unexpended balance of the appropriation made in Sec 19 SLA2021 P117 L7 (HB69) for American Rescue Plan receipts.												
Sec. 1. DEPARTMENT OF LABOR AND WORKFORCE DEVELOPMENT. The amount of federal receipts received from the American Rescue Plan Act of 2021 (P.L. 117-2) for the following purposes in the fiscal years ending June 30, 2021, and June 30, 2022, estimated to be \$441,000, is appropriated to the Department of Labor and Workforce Development for the fiscal years ending June 30, 2021, June 30, 2022, June 30,2023, and June 30, 2024, for the following purposes and in the following estimated amounts:												
PURPOSE		ESTIMATED AMOUNT										
Alaska Vocational Technical Center, higher education emergency relief funds III, institutional portion		\$220,500										
Alaska Vocational Technical Center, higher education emergency relief funds III, student aid portion		\$220,500										
Original Appropriation:		\$441.0										
FY2021 Expenditures:		\$0.0										
FY2022 Carryforward:		\$441.0										
Extend Workforce Investment Board Allocations Ch4 SLA2021 (HB100) (Sec2 Ch1 SSSLA2021 Pg42 L10 (HB69))												
	FisNot	-382.3	0.0	0.0	-382.3	0.0	0.0	0.0	0.0	0	0	0
1151 VoTech Ed		-382.3										
Updated cost to accurately reflect amounts in FY22 Governor's Amended budget and new TVEP funding amount.												
Subtotal		13,965.4	7,770.4	45.2	3,508.3	1,231.8	194.0	1,215.7	0.0	53	13	4

Change Record Detail - Multiple Scenarios with Descriptions
Department of Labor and Workforce Development

Component: Alaska Vocational Technical Center (2686)

RDU: Alaska Vocational Technical Center (578)

Scenario/Change Record Title	Trans Type	Totals	Personal Services	Travel	Services	Commodities	Capital Outlay	Grants, Benefits	Miscellaneous	Positions		NP
										PFT	PPT	
***** Changes From FY2022 Authorized To FY2022 Management Plan *****												
Add Instructors Aide II (07-#004) in Support of Alaska Vocational Technical Center Operations												
PosAdj		0.0	0.0	0.0	0.0	0.0	0.0	0.0	0.0	0	1	0
<p>Add an exempt Instructor's Aide II to assist students and instructors in multiple training programs. The workload will include ensuring training is conducted in a safe manner, tutoring students in program curriculum, and working with instructors to prepare training materials and equipment.</p> <p>- Instructor's Aide II (07-#004), range 13, located in Seward</p>												
Add Grants Administrator II (07-#006)												
PosAdj		0.0	0.0	0.0	0.0	0.0	0.0	0.0	0.0	1	0	0
<p>Add Grants Administrator II to manage multiple grant activities including the Workforce Innovation and Opportunity Act Youth Grant and apprenticeship expansion to enhance the productivity and competitiveness of Alaska's workforce.</p> <p>- Grants Administrator II (07-#006), range 17, located in Seward</p>												
Align Authority with Personal Service Needs												
LIT		0.0	-210.3	0.0	0.0	210.3	0.0	0.0	0.0	0	0	0
<p>Transfer authority from personal services to commodities. The remaining personal services authority is sufficient to cover anticipated expenditures.</p>												
Transfer Program Coordinator 1 (07-5544) from AWIB												
Trin		0.0	0.0	0.0	0.0	0.0	0.0	0.0	0.0	1	0	0
<p>Transfer Program Coordinator I (07-5544), range 17, located in Anchorage from Workforce Investment Board (AWIB) to Alaska Vocational Technical Center (AVTEC), located in Seward. This long-term vacant position in AWIB will be used in AVTEC to manage multiple grant activities including the Workforce Innovation and Opportunity Act Youth Grant and apprenticeship expansion.</p>												
Add Division Operations Manager (07-4583)												
PosAdj		0.0	0.0	0.0	0.0	0.0	0.0	0.0	0.0	1	0	0
<p>Establish a new permanent Division Operations Manager position effective June 1, 2021 and delete the exempt Alaska Vocational Technical Center (AVTEC) Chief of Operations position (07-X088). AVTEC restructured following the May 2021 retirement of the incumbent in the Chief of Operations position. The Division Operations Manager classification is more aligned to fit the needs of the division.</p>												
Delete AVTEC Chief of Operation (07-X088)												
PosAdj		0.0	0.0	0.0	0.0	0.0	0.0	0.0	0.0	-1	0	0
<p>Establish a new permanent Division Operations Manager position effective June 1, 2021 and delete the exempt Alaska Vocational Technical Center (AVTEC) Chief of Operations position (07-X088). AVTEC restructured following the May 2021 retirement of the incumbent in the Chief of Operations position. The Division Operations Manager classification is more aligned to fit the needs of the division.</p>												

Change Record Detail - Multiple Scenarios with Descriptions
Department of Labor and Workforce Development

Component: Alaska Vocational Technical Center (2686)

RDU: Alaska Vocational Technical Center (578)

Scenario/Change Record Title	Trans Type	Totals	Personal Services	Travel	Services	Commodities	Capital Outlay	Grants, Benefits	Miscellaneous	Positions		NP
										PFT	PPT	
Subtotal		13,965.4	7,560.1	45.2	3,508.3	1,442.1	194.0	1,215.7	0.0	55	14	4
***** Changes From FY2022 Management Plan To FY2023 Governor *****												
Reverse American Rescue Plan Receipts Sec 19 SLA2021 P117 L7 (HB69) (FY21-FY24)												
	OTI	-441.0	0.0	0.0	-220.5	-220.5	0.0	0.0	0.0	0	0	0
1265 COVID Fed		-441.0										
Reverse one-time federal authority for funding received from the American Rescue Plan Act of 2021 (P.L. 117-2).												
FY2023 Executive Health Insurance, SBS, and Risk Management Rate Changes												
	SalAdj	3.1	3.1	0.0	0.0	0.0	0.0	0.0	0.0	0	0	0
1004 Gen Fund		1.6										
1007 I/A Rcpts		0.4										
1108 Stat Desig		1.1										
FY2023 Change Partially Exempt & Exempt Executive (EE) - Health Insurance from \$1,555 to \$1,685, SBS, and Risk Management Rates: \$3.1												
FY2023 AVTEC Teachers Health Insurance, SBS, and Risk Management Rate Changes												
	SalAdj	48.8	48.8	0.0	0.0	0.0	0.0	0.0	0.0	0	0	0
1004 Gen Fund		43.2										
1007 I/A Rcpts		3.0										
1108 Stat Desig		2.6										
FY2023 Change AVTEC Teachers Health Insurance from \$1,555 to \$1,685, SBS and Risk Management Rates: \$48.8												
FY2023 Supervisory Employees Health Insurance, SBS, and Risk Management Rate Changes												
	SalAdj	7.9	7.9	0.0	0.0	0.0	0.0	0.0	0.0	0	0	0
1004 Gen Fund		3.2										
1005 GF/Prgm		4.7										
FY2023 Change Supervisory Employees (SS) Health Insurance from \$1,555 to \$1,685, SBS, and Risk Management Rates: \$7.9												
FY2023 General Government Unit SBS and Risk Management Rate Changes												
	SalAdj	1.1	1.1	0.0	0.0	0.0	0.0	0.0	0.0	0	0	0
1004 Gen Fund		0.3										
1005 GF/Prgm		0.4										
1007 I/A Rcpts		0.3										
1108 Stat Desig		0.1										
FY2023 Change General Government Unit (GG, GP, GY, GZ) SBS and Risk Management Rates: \$1.1												

Change Record Detail - Multiple Scenarios with Descriptions
Department of Labor and Workforce Development

Component: Alaska Vocational Technical Center (2686)

RDU: Alaska Vocational Technical Center (578)

Scenario/Change Record Title	Trans Type	Totals	Personal Services	Travel	Services	Commodities	Capital Outlay	Grants, Benefits	Miscellaneous	Positions		NP
										PFT	PPT	
FY2023 Labor, Trades, and Crafts Salary and Benefit Adjustments												
	SalAdj	14.6	14.6	0.0	0.0	0.0	0.0	0.0	0.0	0	0	0
1005 GF/Prgm		14.6										
FY2023 Labor, Trades, and Crafts 3.25% COLA: \$14.6												
FY2023 Labor, Trades, and Crafts SBS and Risk Management Rate Changes												
	SalAdj	14.6	14.6	0.0	0.0	0.0	0.0	0.0	0.0	0	0	0
1005 GF/Prgm		14.6										
FY2023 Change Labor, Trades, and Crafts LTC (LL) SBS and Risk Management Rates: \$0.2												
FY2023 PERS Actuarial Rate Adjustment to 24.79% Ch9 SLA2021 (SB55)												
	SalAdj	-220.9	-220.9	0.0	0.0	0.0	0.0	0.0	0.0	0	0	0
1004 Gen Fund		-130.7										
1005 GF/Prgm		-56.7										
1007 I/A Rcpts		-19.1										
1108 Stat Desig		-14.4										
Includes: FY2023 Adjustment for PERS ARM Board Approved Rate of 24.79% (from 30.11%): \$-220.9												
FY2023 Salary and Benefit Adjustments												
	SalAdj	6.3	6.3	0.0	0.0	0.0	0.0	0.0	0.0	0	0	0
1004 Gen Fund		2.6										
1005 GF/Prgm		3.7										
Includes: FY2023 Supervisory Unit 1% COLA: \$4.1												
FY2023 SU BU - Supervisory Employees (SS) 1% COLA: \$2.2												
Reduce Authority for Planned Instructors Aide Position Moving to Part-Time												
	Dec	-25.0	-23.5	0.0	-1.5	0.0	0.0	0.0	0.0	0	0	0
1004 Gen Fund		-25.0										
Reduce authority for planned Instructors Aide position from full-time to part-time.												
This position will provide oversight for safety of students in Construction Technology, Diesel Heavy Technology, Industrial Electricity, Plumbing & Heating, and Refrigeration training programs. These training programs involve using heavy equipment and power tools and new student users require oversight and management of tools, equipment and supplies in the training labs and shops to ensure an injury free environment. While the position is needed, reducing the funding to part-time is manageable.												

Reduce General Fund Program Receipt Authority

Change Record Detail - Multiple Scenarios with Descriptions
Department of Labor and Workforce Development

Component: Alaska Vocational Technical Center (2686)

RDU: Alaska Vocational Technical Center (578)

Scenario/Change Record Title	Trans Type	Totals	Personal Services	Travel	Services	Commodities	Capital Outlay	Grants, Benefits	Miscellaneous	Positions		
										PFT	PPT	NP
1005 GF/Prgm	Dec	-250.0	0.0	0.0	0.0	-250.0	0.0	0.0	0.0	0	0	0
General Fund Program Receipts (GFPR) are collected from student fees and tuition. This reduction in GFPR authority aligns with anticipated revenue.												
Totals		13,124.9	7,412.1	45.2	3,286.3	971.6	194.0	1,215.7	0.0	55	14	4

Line Item Detail (1676)
Department of Labor and Workforce Development
Travel

Component: Alaska Vocational Technical Center (2686)

Line Number	Line Name		FY2021 Actuals	FY2022 Management Plan	FY2023 Governor
2000	Travel		7.6	45.2	45.2
Object Class	Servicing Agency	Explanation	FY2021 Actuals	FY2022 Management Plan	FY2023 Governor
2000 Travel Detail Totals			7.6	45.2	45.2
2000	In-State Employee Travel	In-state employee travel to support the department's mission.	5.9	28.1	39.8
2001	In-State Non-Employee Travel	In-state non-employee travel.	0.0	2.3	3.0
2002	Out of State Employee Travel	Out of state employee travel.	0.5	6.8	2.4
2003	Out of State Non-Employee Travel	Travel of accreditation team.	1.2	8.0	0.0

Line Item Detail (1676)
Department of Labor and Workforce Development
Services

Component: Alaska Vocational Technical Center (2686)

Line Number	Line Name		FY2021 Actuals	FY2022 Management Plan	FY2023 Governor
3000	Services		3,188.9	3,508.3	3,286.3
Object Class	Servicing Agency	Explanation	FY2021 Actuals	FY2022 Management Plan	FY2023 Governor
3000 Services Detail Totals			3,188.9	3,508.3	3,286.3
3000	Education Services	Training, education, and memberships.	45.6	29.0	26.6
3001	Financial Services	Financial services, including auditing and accounting, consulting, insurance, or interest expense.	1.7	16.9	18.2
3003	Information Technology	Information technology, including training, consulting, leases, and software licensing and maintenance.	171.7	185.7	183.5
3004	Telecommunications	Local, long distance, and cellular telephone charges, television, data/network, telecommunication equipment, and other wireless charges from outside vendors.	108.5	102.3	102.5
3006	Delivery Services	Freight, courier services, and postage.	7.9	10.7	10.7
3007	Advertising and Promotions	Advertising for regulation changes, board meetings, recruitments, or other public notices.	1.3	13.0	13.0
3008	Utilities	Electricity, heating fuel, water, sewage, recycling, heating fuel, trash, and confidential document and other disposal services.	28.6	25.9	25.9
3009	Structure/Infrastructure/Land	Room rental for training and seminar space, board or council meetings, or storage and archiving needs.	0.9	0.9	0.9
3010	Equipment/Machinery	Machinery, furniture, and equipment purchase, repairs, maintenance,	22.9	37.1	28.5

Line Item Detail (1676)
Department of Labor and Workforce Development
Services

Component: Alaska Vocational Technical Center (2686)

Object Class	Servicing Agency	Explanation	FY2021 Actuals	FY2022 Management Plan	FY2023 Governor
3000 Services Detail Totals			3,188.9	3,508.3	3,286.3
		rentals, and leases.			
3011	Other Services	Other services, including interpreters; consulting; print, copy, and graphic services; and safety services.	79.7	80.7	95.1
3012	Inter-Agency Federal Indirect Rate Allocation	Labor - Management Services (335) Indirect cost allocation for departmental purchasing, accounting, reports, personnel consultation and other services provided by Management Services.	429.1	477.2	473.1
3020	Inter-Agency Building Maintenance	Labor - AVTEC Facilities Maintenance (2701) Reimbursable services agreement to support facility maintenance and operations actives for the division.	2,131.6	2,378.5	2,157.9
3021	Inter-Agency Mail	Admin - Department-wide Reimbursable services agreement with Shared Services of Alaska for central mailroom support and services.	1.7	0.0	0.0
3022	Inter-Agency Human Resources	Admin - Department-wide Reimbursable services agreement with the Division of Personnel and Labor Relations for human resources and personnel services.	39.2	46.9	46.9
3025	Inter-Agency Auditing	Admin - Department-wide Reimbursable services agreement with the Department of Administration for auditing services, including federal compliance audits.	4.7	2.7	2.7
3026	Inter-Agency Insurance	Admin - Department-wide Reimbursable services agreement with the Division of Risk Management for risk management insurance charges for leased buildings, repossessed properties, public official bonds, and overhead.	2.6	4.2	4.2
3027	Inter-Agency Financial	Admin - Department-wide Reimbursable services agreement with the Division of Finance for system services for State accounting	31.8	12.3	12.3

Line Item Detail (1676)
Department of Labor and Workforce Development
Services

Component: Alaska Vocational Technical Center (2686)

Object Class	Servicing Agency	Explanation	FY2021 Actuals	FY2022 Management Plan	FY2023 Governor
3000 Services Detail Totals			3,188.9	3,508.3	3,286.3
3029	Inter-Agency Education/Training	Labor - AVTEC (2686)			
		and payroll (IRIS), and reporting (ALDER) systems.			
		Reimbursable services agreement with Workforce Investment Board for oversight under AS 23.15.580(f).	35.0	35.0	35.0
3036	Inter-Agency Safety	EnvCon - Department-wide			
		One-time expense for the Department of Environmental Conservation to evaluate the soil around an underground fuel tank.	1.0	0.0	0.0
3037	State Equipment Fleet				
		State equipment fleet fixed cost services for equipment replacement, maintenance and fuel, both allowable and non-allowable.	43.4	49.3	49.3

Line Item Detail (1676)
Department of Labor and Workforce Development
Commodities

Component: Alaska Vocational Technical Center (2686)

Line Number	Line Name		FY2021 Actuals	FY2022 Management Plan	FY2023 Governor
4000	Commodities		569.7	1,442.1	971.6
Object Class	Servicing Agency	Explanation	FY2021 Actuals	FY2022 Management Plan	FY2023 Governor
4000 Commodities Detail Totals			569.7	1,442.1	971.6
4000	Business	General business supplies such as office consumables and computer equipment.	333.2	669.6	400.1
4002	Household/Institutional	Office supplies, supplies and consumables for public meetings, and cleaning products.	162.3	462.0	261.0
4004	Safety	Safety gear and protective clothing.	7.0	10.0	10.0
4005	Building Materials	Building and maintenance materials, including office and directional signage.	0.6	15.0	15.0
4013	Lube Oils/Grease/Solvents	Lubricants, oil, grease, and solvents.	6.6	15.0	15.0
4014	Bottled Gas	Welding gas.	32.8	30.5	35.0
4015	Parts and Supplies	Parts and supplies.	6.3	120.0	115.5
4019	Small Tools/Minor Equipment	Small tools and minor equipment necessary to make small repairs.	15.1	120.0	120.0
4022	Commodity Transfer	Personal protective equipment for students and staff.	5.8	0.0	0.0

Line Item Detail (1676)
Department of Labor and Workforce Development
Capital Outlay

Component: Alaska Vocational Technical Center (2686)

Line Number	Line Name		FY2021 Actuals	FY2022 Management Plan	FY2023 Governor
5000	Capital Outlay		217.9	194.0	194.0
Object Class	Servicing Agency	Explanation	FY2021 Actuals	FY2022 Management Plan	FY2023 Governor
5000 Capital Outlay Detail Totals			217.9	194.0	194.0
5004	Equipment	Office equipment.	217.9	194.0	194.0

Line Item Detail (1676)
Department of Labor and Workforce Development
Grants, Benefits

Component: Alaska Vocational Technical Center (2686)

Line Number	Line Name		FY2021 Actuals	FY2022 Management Plan	FY2023 Governor
7000	Grants, Benefits		648.3	1,215.7	1,215.7
Object Class	Servicing Agency	Explanation	FY2021 Actuals	FY2022 Management Plan	FY2023 Governor
		7000 Grants, Benefits Detail Totals	648.3	1,215.7	1,215.7
7002	Benefits	Grants and loans to students for tuition and fees.	648.3	1,215.7	1,215.7

Revenue Detail (1681)
Department of Labor and Workforce Development

Component: Alaska Vocational Technical Center (2686)

Revenue Type (OMB Fund Code) Revenue Source	Component	Comment	FY2021 Actuals	FY2022 Management Plan	FY2023 Governor
5002 Fed Rcpts (1002 Fed Rcpts)			617.8	815.3	815.3
5004 Federal Education - Miscellaneous Grants		Federal Pell grants and direct loans passed through to students attending the Alaska Vocational Technical Center for tuition, fees, supplies, and living expenses.	617.8	815.3	815.3
5005 GF/Prgm (1005 GF/Prgm)			1,691.3	3,785.5	3,785.5
5103 Program Receipts - Charges for Services		Student tuition and fees collected as authorized in AS 43.31.020(7). Student tuition and fees collected as authorized in AS 43.31.020(7).	1,691.3	3,785.5	3,785.5
5007 I/A Rcpts (1007 I/A Rcpts)			1,022.8	1,078.3	1,078.3
5301 Inter-Agency Receipts		Inter-agency receipts.	897.8	953.3	953.3
5301 Inter-Agency Receipts	E&ED - Department-wide	Inter-agency receipts.	125.0	125.0	125.0
5108 Stat Desig (1108 Stat Desig)			803.5	1,165.8	1,165.8
5202 Statutory Dsgntd Program Receipts - Tuition/Education Fees		Anticipated shortfall in collection of contractual training charges, donations, and scholarship dollars.	783.1	200.0	200.0
5202 Statutory Dsgntd Program Receipts - Tuition/Education Fees		Contractual training charges, donations, and scholarship dollars.	0.0	945.4	945.4
5208 Statutory Dsgntd Prgrm Rcpts Ntrl Rsrcs - Rent and Royalties		Lease payments for cellular tower.	20.4	20.4	20.4
5265 COVID Fed (1265 COVID Fed)			0.0	441.0	0.0
5028 Federal COVID Stimulus - Miscellaneous Grants		Supplemental federal funding from COVID relief fund.	0.0	441.0	0.0
6151 VoTech Ed (1151 VoTech Ed)			0.0	1,969.4	1,969.4
6775 Technical Vocational Education Program - Contributions		Technical and Vocational Education Program Account (AS 23.15.830) provides funds to support technical and vocational training programs	0.0	1,969.4	1,969.4

Revenue Detail (1681)
Department of Labor and Workforce Development

Component: Alaska Vocational Technical Center (2686)

Revenue Type (OMB Fund Code)	Component	Comment	FY2021 Actuals	FY2022 Management Plan	FY2023 Governor
Revenue Source		across Alaska.			

Inter-Agency Services (1682)

Department of Labor and Workforce Development

Component: Alaska Vocational Technical Center (2686)

	FY2021 Actuals	FY2022 Management Plan	FY2023 Governor
Component Totals	2,676.7	2,956.8	2,732.1
With Department of Labor and Workforce Development	2,595.7	2,890.7	2,666.0
With Department of Administration	80.0	66.1	66.1
With Department of Environmental Conservation	1.0	0.0	0.0

Object Class	Servicing Agency	Explanation	FY2021 Actuals	FY2022 Management Plan	FY2023 Governor
3012 Inter-Agency Federal Indirect Rate Allocation	Labor - Management Services (335)	Indirect cost allocation for departmental purchasing, accounting, reports, personnel consultation and other services provided by Management Services.	429.1	477.2	473.1
3020 Inter-Agency Building Maintenance	Labor - AVTEC Facilities Maintenance (2701)	Reimbursable services agreement to support facility maintenance and operations activities for the division.	2,131.6	2,378.5	2,157.9
3021 Inter-Agency Mail	Admin - Department-wide	Reimbursable services agreement with Shared Services of Alaska for central mailroom support and services.	1.7	0.0	0.0
3022 Inter-Agency Human Resources	Admin - Department-wide	Reimbursable services agreement with the Division of Personnel and Labor Relations for human resources and personnel services.	39.2	46.9	46.9
3025 Inter-Agency Auditing	Admin - Department-wide	Reimbursable services agreement with the Department of Administration for auditing services, including federal compliance audits.	4.7	2.7	2.7
3026 Inter-Agency Insurance	Admin - Department-wide	Reimbursable services agreement with the Division of Risk Management for risk management insurance charges for leased buildings, repossessed properties, public official bonds, and overhead.	2.6	4.2	4.2

Inter-Agency Services (1682)
Department of Labor and Workforce Development

Component: Alaska Vocational Technical Center (2686)

Object Class	Servicing Agency	Explanation	FY2021 Actuals	FY2022 Management Plan	FY2023 Governor
3027 Inter-Agency Financial	Admin - Department-wide	Reimbursable services agreement with the Division of Finance for system services for State accounting and payroll (IRIS), and reporting (ALDER) systems.	31.8	12.3	12.3
3029 Inter-Agency Education/Training	Labor - AVTEC (2686)	Reimbursable services agreement with Workforce Investment Board for oversight under AS 23.15.580(f).	35.0	35.0	35.0
3036 Inter-Agency Safety	EnvCon - Department-wide	One-time expense for the Department of Environmental Conservation to evaluate the soil around an underground fuel tank.	1.0	0.0	0.0

Personal Services Expenditure Detail
Department of Labor and Workforce Development

Scenario: FY2023 Governor (18673)
Component: Alaska Vocational Technical Center (2686)
RDU: Alaska Vocational Technical Center (578)

PCN	Job Class Title	Time Status	Retire Code	Barg Unit	Location	Salary Sched	Range / Step	Comp Months	Split / Count	Annual Salaries	COLA	Premium Pay	Annual Benefits	Total Costs	UGF Amount
05-8001	Division Director - Px	FT	A	XE	Seward	N00	27J / K	12.0		129,568	0	0	68,540	198,108	198,108
05-8013	AVTEC Instructor	FT	A	TA	Seward	99	0	12.0		70,229	0	0	46,419	116,648	116,648
05-8014	Dormitory Attendant	PT	A	GP	Seward	200	11B / C	11.0		36,103	0	2,581	31,638	70,322	0
05-8015	AVTEC Instructor	FT	A	TA	Seward	99	0	12.0		80,223	0	0	50,144	130,367	130,367
05-8099	Food Service, Journey	PT	A	LL	Seward	2CC	57E / F	10.0		37,322	0	3,627	30,830	71,779	0
05-8100	Food Service, Sub-Journey	PT	A	LL	Seward	2CC	61B / C	10.0		24,028	0	2,022	25,276	51,326	0
05-8390	Education Associate 3	FT	A	SS	Seward	600	17L / M	12.0		81,910	1,206	5,907	53,119	142,142	0
05-8395	Administrative Officer 1	FT	A	GP	Seward	200	17F / G	12.0		68,126	0	0	44,179	112,305	0
05-8396	Accounting Technician 3	FT	A	GP	Seward	200	16E / F	12.0		62,381	0	0	42,037	104,418	0
05-8397	Procurement Specialist 1	FT	A	GP	Seward	200	14K / L	12.0		61,942	0	0	41,873	103,815	0
05-8436	Recreation Assistant	PT	A	GP	Seward	200	11K / L	10.0		42,136	0	1,659	31,978	75,773	24,955
05-8507	AVTEC Instructor	FT	A	TA	Seward	99	0	12.0		63,245	0	0	43,815	107,060	107,060
05-8510	AVTEC Instructor	FT	A	TA	Seward	99	0	12.0		65,245	0	0	44,561	109,806	109,806
05-8512	AVTEC Instructor	FT	A	TA	Seward	99	0	12.0		72,315	0	0	47,196	119,511	0
05-8513	AVTEC Instructor	FT	A	TA	Seward	99	0	12.0		103,717	0	0	58,903	162,620	162,620
05-8516	Education Program Assistant	FT	A	GP	Seward	200	12D / E	12.0		44,753	0	0	35,465	80,218	0
05-8517	Teacher - AVTEC	FT	T	TA	Seward	99	0	12.0		103,869	0	0	39,889	143,758	136,714
05-8518	AVTEC Instructor	FT	A	TA	Seward	99	0	12.0		68,491	0	0	45,771	114,262	114,262
05-8520	AVTEC Instructor	FT	A	TA	Seward	99	0	12.0		62,491	0	0	43,534	106,025	106,025
05-8523	AVTEC Instructor	FT	A	TA	Seward	99	0	12.0		78,653	0	0	49,559	128,212	128,212
05-8525	Teacher - AVTEC	FT	T	TA	Seward	99	0	12.0		83,280	0	0	35,994	119,274	119,274
05-8527	Food Service, Foreman	PT	A	LL	Seward	2CC	53J / K	12.0		64,802	0	2,883	43,910	111,595	0
05-8529	Teacher - AVTEC	FT	T	TA	Seward	99	0	12.0		96,713	0	0	38,535	135,248	135,248
05-8530	AVTEC Instructor	FT	A	TA	Seward	99	0	12.0		92,957	0	0	54,892	147,849	147,849
05-8531	AVTEC Instructor	FT	A	TA	Seward	99	0	12.0		94,010	0	0	55,284	149,294	143,292
05-8536	AVTEC Instructor	FT	A	TA	Seward	99	0	12.0		74,630	0	0	48,059	122,689	61,345
05-8537	Education Associate 3	FT	A	SS	Seward	600	17L / M	12.0		81,910	1,124	0	50,917	133,951	133,951
05-8538	Micro/Net Sp 1	FT	A	GP	Seward	200	18A / B	12.0		61,487	0	0	41,704	103,191	103,191
05-8540	AVTEC Instructor	FT	A	TA	Seward	99	0	12.0		114,169	0	0	62,800	176,969	17,515
05-8547	Accounting Technician 2	FT	A	GP	Seward	200	14C / D	12.0		50,410	0	0	37,574	87,984	0
05-8549	Food Service, Lead	PT	A	LL	Seward	2CC	56P	11.0		54,141	0	3,007	38,426	95,574	0
05-8608	Food Service, Journey	PT	A	LL	Seward	2CC	57D / E	10.0		36,095	0	4,726	30,782	71,603	0
05-8609	Dormitory Attendant	PT	A	GP	Seward	200	11J / K	11.0		44,820	0	2,998	35,043	82,861	0
05-8652	Dormitory Attendant	PT	A	GP	Seward	200	11B / C	11.0		35,867	0	3,797	32,003	71,667	0
05-8677	Food Service, Sub-Journey	PT	A	LL	Seward	2CC	61A / B	10.0		23,305	0	1,356	24,758	49,419	0
05-8689	Education Program Assistant	FT	A	GP	Seward	200	12G	12.0		48,672	0	0	36,926	85,598	0
05-8700	Education Program	FT	A	GP	Seward	200	12L / M	12.0		55,775	0	0	39,574	95,349	93,349

Note: If a position is split, an asterisk (*) will appear in the Split/Count column. If the split position is also counted in the component, two asterisks (**) will appear in this column. [No valid job title] appearing in the Job Class Title indicates that the PCN has an invalid class code or invalid range for the class code effective date of this scenario.

Personal Services Expenditure Detail
Department of Labor and Workforce Development

Scenario: FY2023 Governor (18673)
Component: Alaska Vocational Technical Center (2686)
RDU: Alaska Vocational Technical Center (578)

PCN	Job Class Title	Time Status	Retire Code	Barg Unit	Location	Salary Sched	Range / Step	Comp Months	Split / Count	Annual Salaries	COLA	Premium Pay	Annual Benefits	Total Costs	UGF Amount
05-8703	Assistant Education Program	FT	A	GP	Seward	99	12N / O	12.0		59,797	0	0	41,074	100,871	0
05-8706	Assistant Publications Specialist 1	FT	A	GP	Seward	200	13B / C	12.0		44,935	0	0	35,533	80,468	80,468
05-8712	Assistant Education Program	FT	A	GP	Seward	200	12L	12.0		54,093	0	0	38,947	93,040	0
05-8720	Assistant Office Assistant 3	FT	A	GP	Seward	200	11B / C	12.0		39,384	0	0	33,464	72,848	0
07-?004	Instructors Aide 2	PT	A	XE	Seward	N00	13A / B	10.0		9,755	0	0	3,637	13,392	0
07-?008	Grants Administrator 2	FT	A	GG	Seward	200	17A	12.0		55,439	0	0	39,449	94,888	94,888
07-1221	Accountant 4	FT	A	SS	Seward	200	20E / F	12.0		87,268	1,198	0	52,915	141,381	0
07-4550	Sub Teacher - AVTEC	NP	N	XE	Seward	N00	0	10.0		136,815	0	0	13,189	150,004	1,352
07-4551	Student Worker	PT	N	XE	Seward	N00	0A	9.6		19,476	0	0	10,527	30,003	0
07-4555	AVTEC Instructor	FT	A	TA	Seward	99	0	12.0		92,939	0	0	54,885	147,824	147,824
07-4559	AVTEC Instructor	FT	A	TA	Seward	99	0	12.0		77,217	0	0	49,024	126,241	550
07-4560	AVTEC Instructor	FT	A	TA	Seward	99	0	12.0		91,118	0	0	54,206	145,324	145,324
07-4563	AVTEC Instructor	FT	A	TA	Seward	99	0	12.0		80,669	0	0	50,311	130,980	130,980
07-4565	AVTEC Instructor	FT	A	TA	Seward	99	0	12.0		88,562	0	0	53,253	141,815	72,330
07-4566	AVTEC Instructor	FT	A	TA	Seward	99	0	12.0		78,368	0	0	49,453	127,821	127,821
07-4567	AVTEC Instructor	FT	A	TA	Seward	99	0	12.0		61,368	0	0	43,115	104,483	104,483
07-4568	Accounting Technician 3	FT	A	GP	Seward	200	16F / G	12.0		64,347	0	0	42,770	107,117	0
07-4571	Food Service, Sub-Journey	PT	A	LL	Seward	2CC	61D / E	10.0		25,506	0	934	25,421	51,861	0
07-4573	AVTEC Instructor	FT	A	TA	Seward	99	0	12.0		90,959	0	0	54,147	145,106	141,105
07-4574	Food Service, Sub-Journey	PT	A	LL	Seward	2CC	61D / E	10.0		25,855	0	1,961	25,934	53,750	0
07-4575	AVTEC Instructor	FT	A	TA	Seward	99	0	12.0		68,491	0	0	45,771	114,262	114,262
07-4576	AVTEC Instructor	FT	A	TA	Seward	99	0	12.0		72,663	0	0	47,326	119,989	112,355
07-4577	AVTEC Instructor	FT	A	TA	Seward	99	0	12.0		81,021	0	0	50,442	131,463	131,463
07-4580	Data Processing Manager 1	FT	A	SS	Seward	200	22K / L	12.0		111,883	1,536	0	62,091	175,510	175,510
07-4581	Internet Specialist 1	FT	A	GP	Seward	200	16B / C	12.0		54,321	0	0	39,032	93,353	93,353
07-4582	Micro/Net Sp 1	FT	A	GP	Seward	200	18E / F	12.0		70,485	0	0	45,058	115,543	115,543
07-4583	Division Operations Manager	FT	A	SS	Seward	200	24A / B	12.0		101,474	1,393	0	58,211	161,078	0
07-5544	Program Coordinator 1	FT	A	GP	Seward	200	18A / B	12.0		61,487	0	0	41,704	103,191	0
07-5867	Assistant Education Program	FT	A	GP	Seward	200	12B / C	12.0		41,339	0	0	34,193	75,532	0
07-7011	AVTEC Instructor	FT	A	TA	Seward	99	0	12.0		89,068	0	0	53,442	142,510	142,510
07-7012	AVTEC Instructor	FT	A	TA	Seward	99	0	12.0		92,889	0	0	54,866	147,755	147,755
07-7013	AVTEC Instructor	FT	A	TA	Seward	99	0	12.0		100,441	0	0	57,682	158,123	144,722
07-8552	AVTEC Instructor	FT	A	TA	Seward	99	0	12.0		69,186	0	0	46,030	115,216	115,216
07-IN2001	Student Intern 1	NP	N	EE	Seward	N00	6A	9.0		8,210	0	0	791	9,001	0

Note: If a position is split, an asterisk (*) will appear in the Split/Count column. If the split position is also counted in the component, two asterisks (**) will appear in this column.
[No valid job title] appearing in the Job Class Title indicates that the PCN has an invalid class code or invalid range for the class code effective date of this scenario.

Personal Services Expenditure Detail
Department of Labor and Workforce Development

Scenario: FY2023 Governor (18673)
Component: Alaska Vocational Technical Center (2686)
RDU: Alaska Vocational Technical Center (578)

PCN	Job Class Title	Time Status	Retire Code	Barg Unit	Location	Salary Sched	Range / Step	Comp Months	Split / Count	Annual Salaries	COLA	Premium Pay	Annual Benefits	Total Costs	UGF Amount
07-N07029	Food Service, Sub-Journey	NP	N	LL	Seward	2CC	61A	11.0		14,595	0	0	1,407	16,002	0
07-N07031	Dormitory Attendant	NP	N	GP	Seward	200	11A	11.0		21,895	0	0	2,111	24,006	0
													Total Salary Costs:	4,813,108	
													Total COLA:	6,457	
													Total Premium Pay:	37,458	
													Total Benefits:	2,993,318	
													Total Pre-Vacancy:	7,850,341	
													Minus Vacancy Adjustment of 5.58%:	(438,241)	
													Total Post-Vacancy:	7,412,100	
													Plus Lump Sum Premium Pay:	0	
													Personal Services Line 100:	7,412,100	

	Total Positions	New	Deleted
Full Time Positions:	55	0	0
Part Time Positions:	14	0	0
Non Permanent Positions:	4	0	0
Positions in Component:	73	0	0

Total Component Months: 846.6

PCN Funding Sources:	Pre-Vacancy	Post-Vacancy	Percent
1004 General Fund Receipts	4,629,605	4,371,160	58.97%
1005 General Fund/Program Receipts	2,132,697	2,013,640	27.17%
1007 Interagency Receipts	548,737	518,104	6.99%
1108 Statutory Designated Program Receipts	539,303	509,197	6.87%
Total PCN Funding:	7,850,341	7,412,100	100.00%

Note: If a position is split, an asterisk (*) will appear in the Split/Count column. If the split position is also counted in the component, two asterisks (**) will appear in this column. [No valid job title] appearing in the Job Class Title indicates that the PCN has an invalid class code or invalid range for the class code effective date of this scenario.

Department of Labor and Workforce Development
 Alaska Vocational Technical Center
 FY2023 Governor Organization Chart

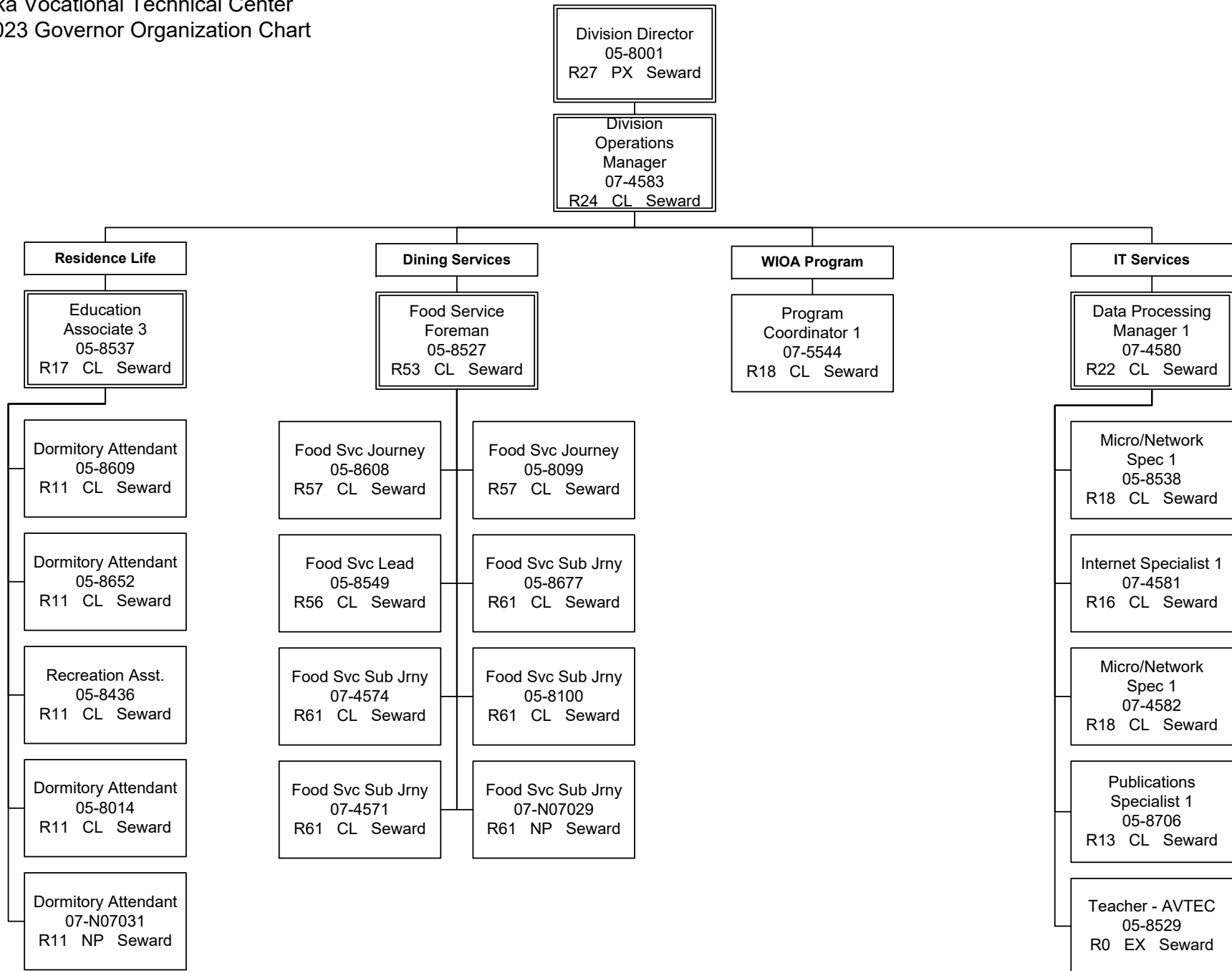

Department of Labor and Workforce Development
 Alaska Vocational Technical Center
 FY2023 Governor Organization Chart

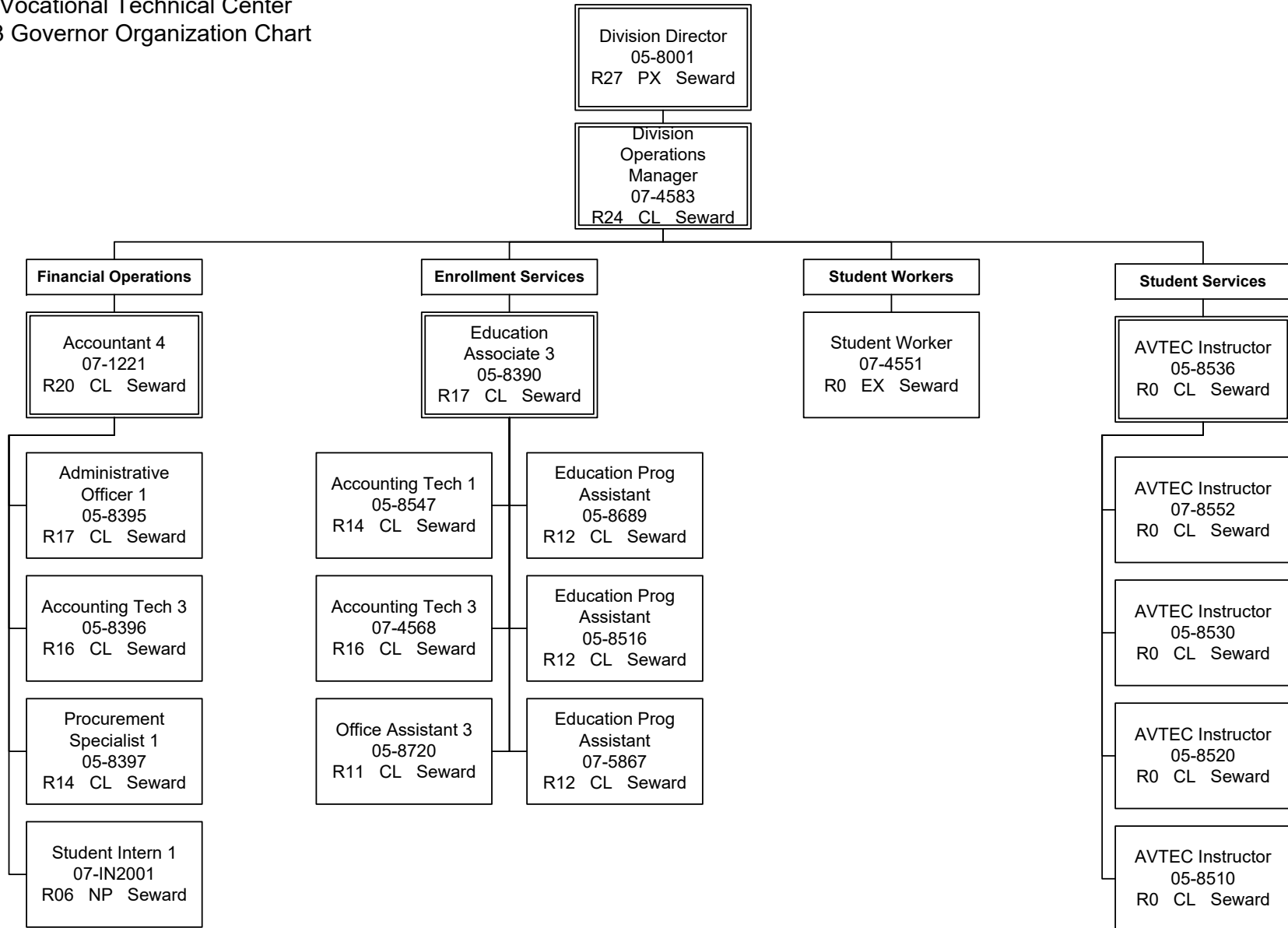

Department of Labor and Workforce Development
Alaska Vocational Technical Center
FY2023 Governor Organization Chart

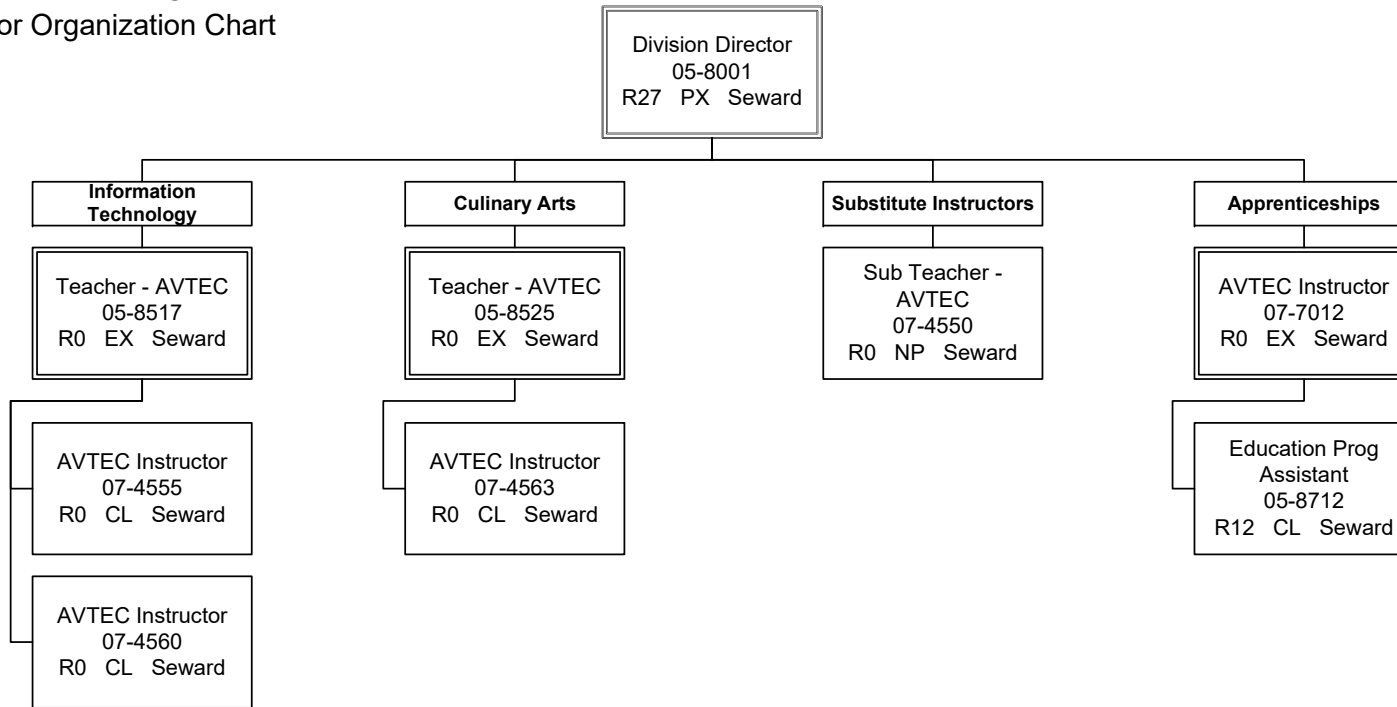

Department of Labor and Workforce Development
 Alaska Vocational Technical Center
 FY2023 Governor Organization Chart

