

**State of Alaska
FY2023 Governor's Operating Budget**

**Department of Law
Office of the Attorney General
Component Budget Summary**

Component: Office of the Attorney General

Contribution to Department's Mission

The Attorney General is the state's chief law enforcement officer, overseeing the state's involvement in all civil matters and criminal prosecutions, and leading over 500 attorneys and staff in the Department of Law's twelve offices throughout the state. The Attorney General serves as co-chair with the Chief Justice of the Alaska Supreme Court of the Alaska Criminal Justice Working Group and trustee on the Exxon Valdez Oil Spill Trustee Council.

Core Services

- Protecting the safety and physical and financial well-being of Alaskans.
- Fostering the conditions for economic opportunity and for the responsible development and use of our natural resources.
- Protecting the fiscal integrity of the State of Alaska.
- Promoting and defending good governance.

Major Component Accomplishments in 2021

Major accomplishments are shown at the department level.

Key Component Challenges

Key component challenges are shown at the department level.

Significant Changes in Results to be Delivered in FY2023

Changes in results are shown at the department level.

Statutory and Regulatory Authority

AS 44.23.020

Contact Information

Contact: Treg Taylor, Attorney General
Phone: (907) 269-5100
E-mail: treg.taylor@alaska.gov

Office of the Attorney General Personal Services Information				
Authorized Positions			Personal Services Costs	
	<u>FY2022</u> <u>Management</u> <u>Plan</u>	<u>FY2023</u> <u>Governor</u>		
Full-time	4	4	Annual Salaries	430,532
Part-time	0	0	Premium Pay	0
Nonpermanent	0	0	Annual Benefits	239,826
			<i>Less 1.65% Vacancy Factor</i>	(11,058)
			Lump Sum Premium Pay	0
Totals	4	4	Total Personal Services	659,300

Position Classification Summary					
Job Class Title	Anchorage	Fairbanks	Juneau	Others	Total
Commissioner	1	0	0	0	1
Executive Secretary 3	1	0	0	0	1
Sp Asst Commr 2	2	0	0	0	2
Totals	4	0	0	0	4

Component Detail All Funds
Department of Law

Component: Office of the Attorney General (2162)
RDU: Administration and Support (280)

Non-Formula Component

	FY2021 Actuals	FY2022 Conference Committee	FY2022 Authorized	FY2022 Management Plan	FY2023 Governor	FY2022 Management Plan vs FY2023 Governor	
71000 Personal Services	665.1	649.0	649.0	664.0	659.3	-4.7	-0.7%
72000 Travel	10.5	39.3	39.3	39.3	39.3	0.0	0.0%
73000 Services	243.2	38.8	38.8	23.8	13.8	-10.0	-42.0%
74000 Commodities	30.1	13.0	13.0	13.0	13.0	0.0	0.0%
75000 Capital Outlay	53.9	0.0	0.0	0.0	0.0	0.0	0.0%
77000 Grants, Benefits	0.0	0.0	0.0	0.0	0.0	0.0	0.0%
78000 Miscellaneous	0.0	0.0	0.0	0.0	0.0	0.0	0.0%
Totals	1,002.8	740.1	740.1	740.1	725.4	-14.7	-2.0%
Fund Sources:							
1004 Gen Fund (UGF)	344.3	551.6	551.6	551.6	534.6	-17.0	-3.1%
1007 I/A Rcpts (Other)	658.5	188.5	188.5	188.5	190.8	2.3	1.2%
Unrestricted General (UGF)	344.3	551.6	551.6	551.6	534.6	-17.0	-3.1%
Designated General (DGF)	0.0	0.0	0.0	0.0	0.0	0.0	0.0%
Other Funds	658.5	188.5	188.5	188.5	190.8	2.3	1.2%
Federal Funds	0.0	0.0	0.0	0.0	0.0	0.0	0.0%
Positions:							
Permanent Full Time	5	4	4	4	4	0	0.0%
Permanent Part Time	0	0	0	0	0	0	0.0%
Non Permanent	0	0	0	0	0	0	0.0%

Change Record Detail - Multiple Scenarios with Descriptions
Department of Law

Component: Office of the Attorney General (2162)
RDU: Administration and Support (280)

Scenario/Change Record Title	Trans Type	Totals	Personal Services	Travel	Services	Commodities	Capital Outlay	Grants, Benefits	Miscellaneous	Positions		NP
										PFT	PPT	
***** Changes From FY2022 Conference Committee To FY2022 Authorized *****												
FY2022 Conference Committee												
	ConfCom	740.1	649.0	39.3	38.8	13.0	0.0	0.0	0.0	4	0	0
1004 Gen Fund		551.6										
1007 I/A Rcpts		188.5										
Subtotal		740.1	649.0	39.3	38.8	13.0	0.0	0.0	0.0	4	0	0
***** Changes From FY2022 Authorized To FY2022 Management Plan *****												
Transfer Authority from Services for Anticipated Personal Service Expenditures												
	LIT	0.0	15.0	0.0	-15.0	0.0	0.0	0.0	0.0	0	0	0
Transfer authority from the services line to the personal services line for anticipated personal services costs. The remaining services authority is anticipated to be sufficient to cover operating expenditures.												
Subtotal		740.1	664.0	39.3	23.8	13.0	0.0	0.0	0.0	4	0	0
***** Changes From FY2022 Management Plan To FY2023 Governor *****												
FY2023 Executive Health Insurance, SBS, and Risk Management Rate Changes												
	SalAdj	7.6	7.6	0.0	0.0	0.0	0.0	0.0	0.0	0	0	0
1004 Gen Fund		5.3										
1007 I/A Rcpts		2.3										
FY2023 Change Partially Exempt & Exempt Executive (EE) - Health Insurance from \$1,555 to \$1,685; SBS and Risk Management Rates: \$7.6												
FY2023 PERS Actuarial Rate Adjustment to 24.79% Ch9 SLA2021 (SB55)												
	SalAdj	-22.3	-22.3	0.0	0.0	0.0	0.0	0.0	0.0	0	0	0
1004 Gen Fund		-16.1										
1007 I/A Rcpts		-6.2										
Includes: FY2023 Adjustment for PERS ARM Board Approved Rate of 24.79% (from 30.11%): \$-22.3												
Realign PERS Rate Adjustment by Fund Source Ch9 SLA2021 (SB55)												
	FndChg	0.0	0.0	0.0	0.0	0.0	0.0	0.0	0.0	0	0	0
1004 Gen Fund		-6.2										
1007 I/A Rcpts		6.2										
Remove one-time UGF subsidy for rate agency assigned in SB55 fiscal note (Ch 9 SLA 2021).												
Transfer Authority to Personal Services for Anticipated Expenditures												
	LIT	0.0	10.0	0.0	-10.0	0.0	0.0	0.0	0.0	0	0	0

Change Record Detail - Multiple Scenarios with Descriptions
Department of Law

Component: Office of the Attorney General (2162)
RDU: Administration and Support (280)

Scenario/Change Record Title	Trans Type	Totals	Personal Services	Travel	Services	Commodities	Capital Outlay	Grants, Benefits	Miscellaneous	Positions		
										PFT	PPT	NP
Transfer authority to the personal services line from the services line for anticipated costs. The remaining services authority is anticipated to be sufficient to cover operating expenditures.												
	Totals	725.4	659.3	39.3	13.8	13.0	0.0	0.0	0.0	4	0	0

Line Item Detail (1676)
Department of Law
Travel

Component: Office of the Attorney General (2162)

Line Number	Line Name		FY2021 Actuals	FY2022 Management Plan	FY2023 Governor
2000	Travel		10.5	39.3	39.3
Object Class	Servicing Agency	Explanation	FY2021 Actuals	FY2022 Management Plan	FY2023 Governor
2000 Travel Detail Totals			10.5	39.3	39.3
2000	In-State Employee Travel	Travel for attorneys to interview witnesses and attend court proceedings, as well as for necessary training for both attorneys and paraprofessionals. Includes travel for management purposes.	10.5	24.3	24.3
2002	Out of State Employee Travel	Travel costs and expenses for out-of-state travel for conferences, training, etc.	0.0	15.0	15.0

Line Item Detail (1676)
Department of Law
Services

Component: Office of the Attorney General (2162)

Line Number	Line Name		FY2021 Actuals	FY2022 Management Plan	FY2023 Governor
3000	Services		243.2	23.8	13.8
Object Class	Servicing Agency	Explanation	FY2021 Actuals	FY2022 Management Plan	FY2023 Governor
3000 Services Detail Totals			243.2	23.8	13.8
3000	Education Services	Conferences, training and memberships.	32.8	3.9	3.9
3002	Legal and Judicial Services	Depositions, research costs, expert witness and consultant fees.	9.6	0.6	0.6
3003	Information Technology	Training, consulting and software licensing and maintenance. Annual maintenance fee for mission-critical information management systems.	102.3	10.1	0.1
3004	Telecommunications	Local telephone service, long distance charges and cellular phone services paid to third-party telephone utilities.	5.9	1.8	1.8
3007	Advertising and Promotions	Publication of legal notices.	0.1	0.1	0.1
3009	Structure/Infrastructure/Land	Rentals/leases - records and evidence storage.	0.1	0.1	0.1
3011	Other Services	Cost transfers and miscellaneous items within the services line (commissions, etc.).	0.1	0.1	0.1
3013	Inter-Agency Data Processing Operations Allocation	Law - Administrative Services (2164) RSA Law, Information services, data processing investments and support.	1.9	0.1	0.1
3017	Inter-Agency Information Technology Non-Telecommunications	Admin - Department-wide RSA Administration, Office of Information Technology computer services.	20.0	1.9	1.9
3018	Inter-Agency Information Technology Telecommunications	Admin - Department-wide RSA Administration, Office of Information Technology telecommunications services.	2.6	1.1	1.1

Line Item Detail (1676)
Department of Law
Services

Component: Office of the Attorney General (2162)

Object Class	Servicing Agency	Explanation	FY2021 Actuals	FY2022 Management Plan	FY2023 Governor	
3000 Services Detail Totals			243.2	23.8	13.8	
3022	Inter-Agency Human Resources	Law - Administrative Services (2164)	RSA Law, Human Resources position.	4.6	2.7	2.7
3023	Inter-Agency Building Leases	Admin - Department-wide	Leased office space managed by General Services.	47.1	0.5	0.5
3026	Inter-Agency Insurance	Admin - Department-wide	RSA Administration, Risk Management.	15.3	0.1	0.1
3027	Inter-Agency Financial	Admin - Department-wide	RSA Administration, Finance Chargeback (IRIS).	0.8	0.7	0.7

Line Item Detail (1676)

**Department of Law
Commodities**

Component: Office of the Attorney General (2162)

Line Number	Line Name		FY2021 Actuals	FY2022 Management Plan	FY2023 Governor
4000	Commodities		30.1	13.0	13.0
Object Class	Servicing Agency	Explanation	FY2021 Actuals	FY2022 Management Plan	FY2023 Governor
4000 Commodities Detail Totals			30.1	13.0	13.0
4000	Business	Reference materials and subscriptions, including statutes, software applications, non-capital desktop refresh, and miscellaneous office supplies.	30.0	12.5	12.5
4002	Household/Institutional	Institutional supplies for cleaning and maintenance.	0.1	0.5	0.5

Line Item Detail (1676)

**Department of Law
Capital Outlay**

Component: Office of the Attorney General (2162)

Line Number	Line Name		FY2021 Actuals	FY2022 Management Plan	FY2023 Governor
5000	Capital Outlay		53.9	0.0	0.0
Object Class	Servicing Agency	Explanation	FY2021 Actuals	FY2022 Management Plan	FY2023 Governor
5000 Capital Outlay Detail Totals			53.9	0.0	0.0
5004	Equipment	Equipment purchases.	53.9	0.0	0.0

Revenue Detail (1681)
Department of Law

Component: Office of the Attorney General (2162)

Revenue Type (OMB Fund Code) Revenue Source	Component	Comment	FY2021 Actuals	FY2022 Management Plan	FY2023 Governor
5007 I/A Rcpts (1007 I/A Rcpts)			658.5	188.5	190.8
5301 Inter-Agency Receipts	Law - Dep. Attny General's Office (2205)	RSA Law - Deputy Attorney General's Office - legal support services for the Civil Division. Program code: AG03501655.	472.5	188.5	190.8
5301 Inter-Agency Receipts	Law - Information and Project Support (2258)	RSA Law - Information and Project Support	186.0	0.0	0.0

Inter-Agency Services (1682)
Department of Law

Component: Office of the Attorney General (2162)

				FY2021 Actuals	FY2022 Management Plan	FY2023 Governor
Component Totals				92.3	7.1	7.1
With Department of Law				6.5	2.8	2.8
With Department of Administration				85.8	4.3	4.3
Object Class	Servicing Agency	Explanation		FY2021 Actuals	FY2022 Management Plan	FY2023 Governor
3013	Inter-Agency Data Processing Operations Allocation	Law - Administrative Services (2164)	RSA Law, Information services, data processing investments and support.	1.9	0.1	0.1
3017	Inter-Agency Information Technology Non-Telecommunications	Admin - Department-wide	RSA Administration, Office of Information Technology computer services.	20.0	1.9	1.9
3018	Inter-Agency Information Technology Telecommunications	Admin - Department-wide	RSA Administration, Office of Information Technology telecommunications services.	2.6	1.1	1.1
3022	Inter-Agency Human Resources	Law - Administrative Services (2164)	RSA Law, Human Resources position.	4.6	2.7	2.7
3023	Inter-Agency Building Leases	Admin - Department-wide	Leased office space managed by General Services.	47.1	0.5	0.5
3026	Inter-Agency Insurance	Admin - Department-wide	RSA Administration, Risk Management.	15.3	0.1	0.1
3027	Inter-Agency Financial	Admin - Department-wide	RSA Administration, Finance Chargeback (IRIS).	0.8	0.7	0.7

Personal Services Expenditure Detail
Department of Law

Scenario: FY2023 Governor (18673)
Component: Office of the Attorney General (2162)
RDU: Administration and Support (280)

PCN	Job Class Title	Time Status	Retire Code	Barg Unit	Location	Salary Sched	Range / Step	Comp Months	Split / Count	Annual Salaries	COLA	Premium Pay	Annual Benefits	Total Costs	UGF Amount
03-0001	Commissioner	FT	A	XE	Anchorage	N00	0	12.0		169,709	0	0	82,010	251,719	251,719
03-0012	Executive Secretary 3	FT	A	XE	Anchorage	N00	16J	12.0		64,292	0	0	44,173	108,465	108,465
03-0310	Sp Asst Commr 2	FT	A	XE	Anchorage	N00	23K	12.0		106,256	0	0	59,796	166,052	119,557
03-0371	Sp Asst Commr 2	FT	A	XE	Anchorage	N00	23C / D	12.0		90,275	0	0	53,847	144,122	0
													Total Salary Costs:	430,532	
													Total COLA:	0	
													Total Premium Pay:	0	
													Total Benefits:	239,826	
													Total Pre-Vacancy:	670,358	
													Minus Vacancy Adjustment of 1.65%:	(11,058)	
													Total Post-Vacancy:	659,300	
													Plus Lump Sum Premium Pay:	0	
													Personal Services Line 100:	659,300	
Total Component Months:		48.0													

PCN Funding Sources:	Pre-Vacancy	Post-Vacancy	Percent
1004 General Fund Receipts	479,741	471,828	71.56%
1007 Interagency Receipts	190,617	187,472	28.44%
Total PCN Funding:	670,358	659,300	100.00%

Note: If a position is split, an asterisk (*) will appear in the Split/Count column. If the split position is also counted in the component, two asterisks (**) will appear in this column. [No valid job title] appearing in the Job Class Title indicates that the PCN has an invalid class code or invalid range for the class code effective date of this scenario.

Administration and Support

Office of the Attorney General

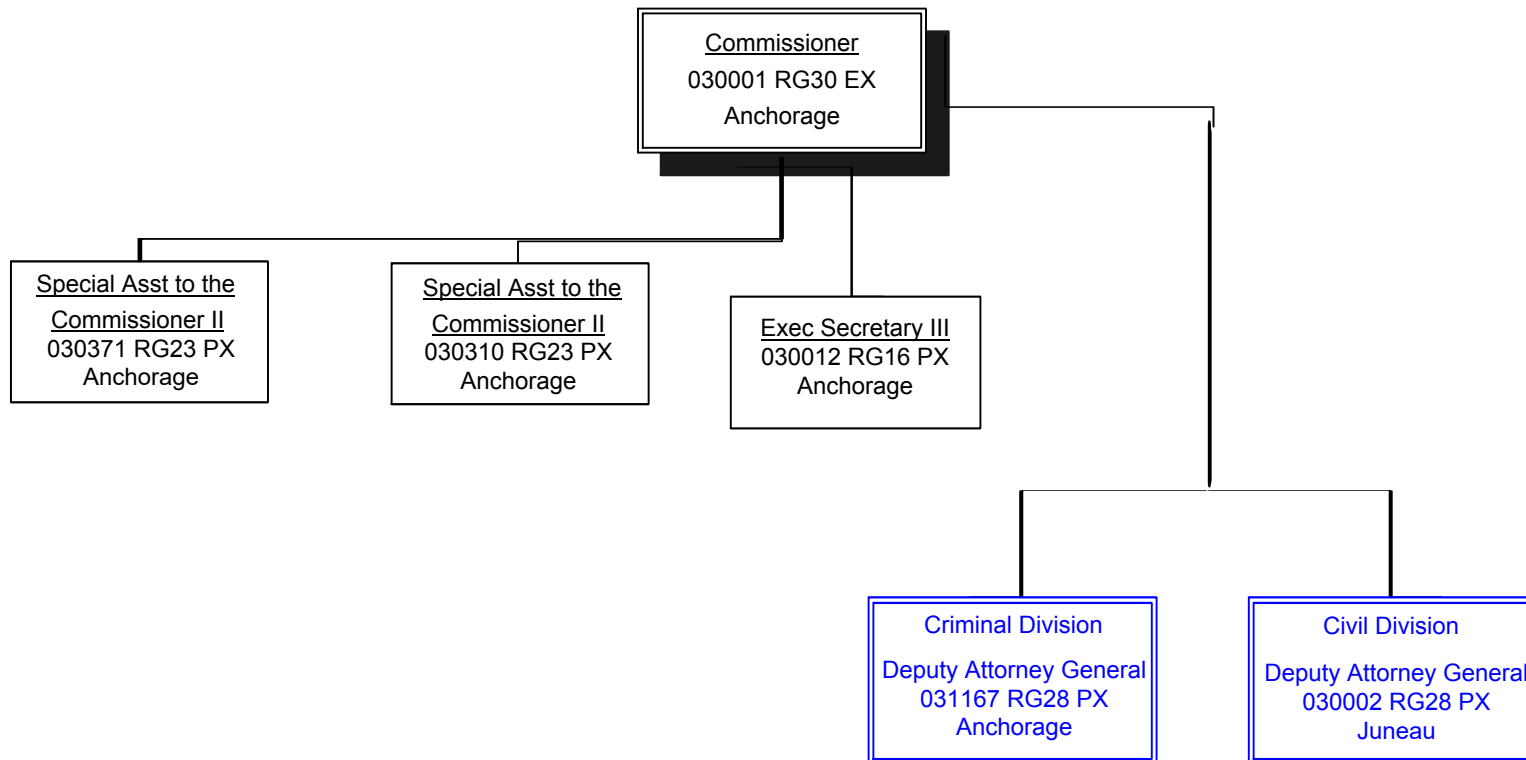

Note: Positions outlined in blue indicate that the PCNs are counted elsewhere but shown here to indicate organizational hierarchy.

Position Count: 4