

State of Alaska FY2023 Governor's Operating Budget

Department of Law

FY2023 Governor Table of Contents

Department of Law	3
RDU: Criminal Division	17
First Judicial District	23
Second Judicial District	37
Third Judicial District: Anchorage	51
Third Judicial District: Outside Anchorage	68
Fourth Judicial District	84
Criminal Justice Litigation	100
Criminal Appeals/Special Litigation	116
RDU: Civil Division (Excludes Janus)	136
Deputy Attorney General's Office	144
Child Protection	159
Commercial and Fair Business	175
Environmental Law	195
Human Services	209
Labor and State Affairs	226
Legislation/Regulations	247
Natural Resources	263
Opinions, Appeals and Ethics	284
Regulatory Affairs Public Advocacy	298
Special Litigation	314
Information and Project Support	328
Torts & Workers' Compensation	345
Transportation Section	361
RDU: Administration and Support	375
Office of the Attorney General	379
Administrative Services	394
Department of Law State Facilities Rent	409
Legal Contracts Janus v AFSCME Decision	415

Department of Law

Mission

The mission of the Alaska Department of Law is to prosecute crime and provide legal services to state government for the protection and benefit of Alaska's citizens. AS 44.23

	Core Services (in priority order)	UGF	DGF	Other	Fed	Total	PFT	PPT	NP	% GF
1	Protecting Alaskans	48,257.7	2,776.5	14,184.1	2,035.5	67,253.8	413.0	0.0	0.0	78.8%
2	Economic Opportunity and Resource Development	6,451.7	0.0	7,945.1	0.0	14,396.8	52.6	0.0	0.0	10.0%
3	State Fiscal Protection	2,421.9	0.0	5,878.5	0.0	8,300.4	45.7	0.0	0.0	3.7%
4	Governance	4,821.9	0.0	4,480.6	0.0	9,302.5	39.7	0.0	0.0	7.4%
	FY2022 Management Plan	61,953.2	2,776.5	32,488.3	2,035.5	99,253.5	551.0	0.0	0.0	

Measures by Core Service

(Additional performance information is available on the web at <https://omb.alaska.gov/results>.)

1. Protecting Alaskans

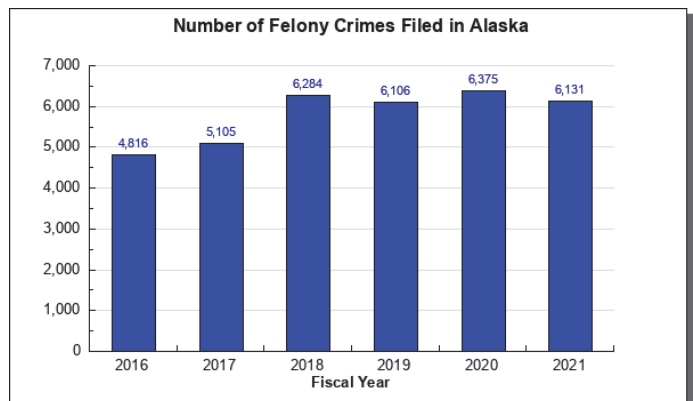
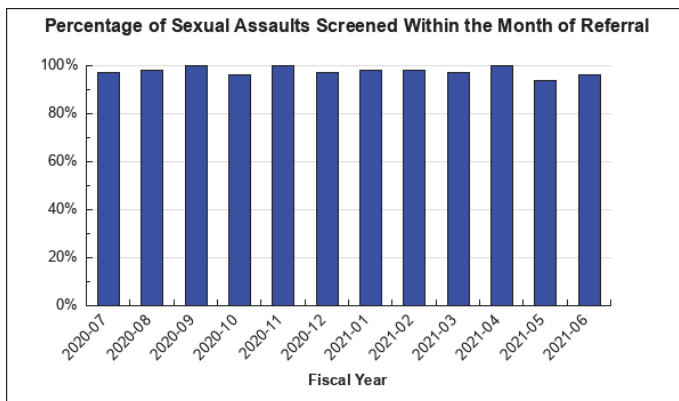

2. Economic Opportunity and Resource Development

3. State Fiscal Protection

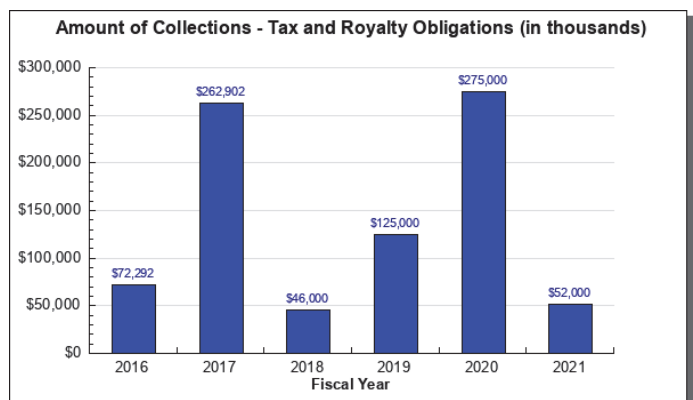
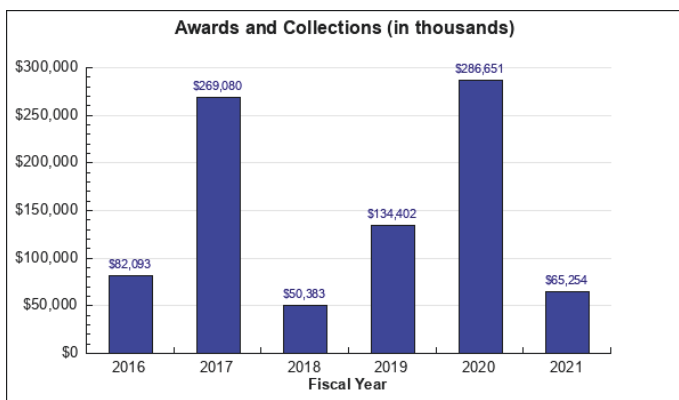

4. Governance

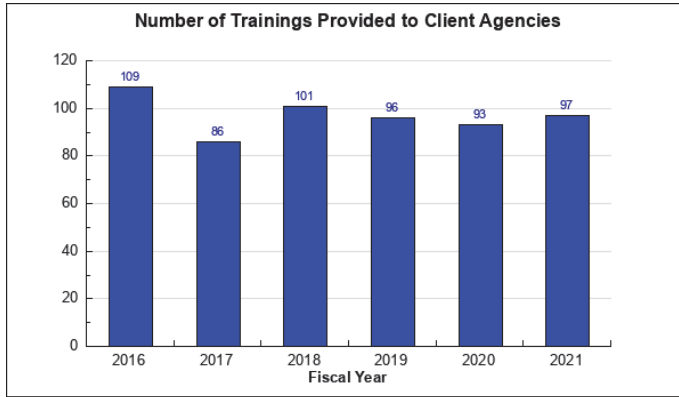

Major Department Accomplishments in 2021

Protecting the Safety and Physical and Financial Well-being of Alaskans

Criminal Division

The impacts of COVID-19 dominated the landscape of the criminal justice system in FY2021. Despite the global pandemic, the Criminal Division kept its personnel healthy and continued its mission. The division nimbly adapted its offices to manage the health of the employees. Over 50% of the division's employees transitioned to work from home while those that remained in the offices followed health and safety protocols, which allowed the division to avoid any significant outbreaks amongst employees that could have otherwise interfered with the division's ability to achieve its mission of protecting Alaskans.

The division maintained its level of felony filings despite the pandemic and its impact on the ability to safely work in the office. The division's felony filings, tracked by fiscal year, continued at a robust level comparable to the previous three years FY 2018-2020. FY2018-2020 saw significant increases in filings compared to previous years and the crime rate began dropping from its high in FY2017. Alaska's crime rate fell for the third year in a row in CY2020 according to the Department of Public Safety's "Crime in Alaska 2020" report. From CY2019 to CY2020 the overall crime rate dropped 18.5%, for an overall 29.5% decrease in the crime rate since CY2017. The increase in felony filings at the same time as a drop in the crime rates provides positive results in public safety for Alaska. This bodes well for public safety if the Criminal Division is able to maintain its current level of resources.

The division also managed to conduct a handful of jury trials during a very challenging period of the pandemic (July 2020 – May 2021) when almost all jury trials were suspended. Those cases focused on sex crimes and domestic violence crimes. Jury trials are a key component to the criminal justice system as the threat of an imminent trial incentivizes defendants to resolve their cases to avoid sentences that might be greater if a case proceeded to trial. While it would have been preferable to have conducted more trials during this time frame, health and safety of all participants (jury, judges, lawyers, other court personnel, etc.) did not allow this at the heights of the pandemic. Once trials resumed in June of 2021, the division conducted 70 jury trials over the next two months before jury trials were once again suspend for health and safety reasons.

The division also maintained a high output level, both in quality and quantity, of appellate briefs. This is significant due to the appellate delay issues that have plagued the criminal justice system for the past decade. The delay in processing criminal appeals has grown to point where the courts now routinely grant extensions of time to file briefing by hundreds of days for each case. This means cases on appeal can take over 2-3 years to be decided. The Criminal Division has keep its length of extensions to almost half of the time the defense has been taking.

Civil Division

- Child Protection. In FY2021, the section managed very substantial Child-In-Need-of-Aid (CINA) caseloads while working to improve the child protection system and foster state-tribal relations to better protect children. The section primarily litigates cases at the trial court level with 25 attorneys to handle approximately 3,100 individual CINA cases.
- Human Services. In FY2021, the section advised the Governor's office on legal issues related to public health in the context of COVID-19. It also continued to advise DHSS on the implementation of Ch. 25 SLA 2016 (SB 74, Medicaid Reform), including the implementation of the 1115 Waiver to transform the behavioral health system in Alaska, estimated to save the state millions of general fund dollars in the coming fiscal years. The section also handled many contested evidentiary hearings statewide related to guardianships, conservatorships and mental commitments.
- Commercial and Fair Business. The attorneys in this section successfully prosecuted or negotiated settlements in 25 professional discipline, license denial, license reinstatement, and unlicensed activity matters. These cases resulted in various actions including revocation, surrender, fines, reprimand, suspension, license conditions, or denial of a license.
- Regulatory Affairs and Public Advocacy. The section's advocacy yielded approximately \$1.5 million in quantifiable consumer benefits in FY2021. This figure is based on refunds issued or the difference between the amounts requested by utilities in their respective revenue requirement proposals and the amounts ultimately awarded to them by the Regulatory Commission of Alaska.

Fostering the Conditions for Economic Opportunity and Responsible Development and Use of Alaska's Natural Resources

- Natural Resources. Section attorneys litigated against federal agencies to challenge National Park Service and U.S. Fish and Wildlife Service regulations that prohibit the state from exercising its full authority to manage fish and game within federal parks and refuges. The section also brought the state into federal litigation to defend the federal authorizations for the ANWR leasing.
- Labor and State Affairs. The section assisted the Alaska Industrial Development and Export Authority (AIDEA) in administration of the emergency small business relief program developed from the state's Coronavirus relief funding. It also assisted AIDEA in negotiating and drafting various loan guarantees and workouts relating to CARES Act funding and business disruptions resulting from the COVID pandemic, as well as assisting AIDEA on natural resource-related projects, including issues related to the development of the Ambler Mining District industrial access road, West Susitna access road, and Section 1002 Arctic National Wildlife Refuge.
- Transportation. Section attorneys are providing legal support for the Department of Transportation and Public Facilities land acquisition for highway and airport projects throughout Alaska, and in right-of-way acquisitions for major projects on the Parks, Glenn, Seward, and Richardson Highways, and in the City of Fairbanks.

Protecting the Fiscal Integrity of the State

- Natural Resources. In FY2020, the section's work resulted in the collection of over \$275 million in additional tax and royalty payments, and attorney's fees.
- Labor and State Affairs. Section attorneys provided extensive legal advice and representation to the Department of Administration, Division of Retirement and Benefits, in numerous health and benefits appeals and coverage issues under the state's health care plans, and on proposed state health and pension plan changes.
- Torts and Workers' Compensation. The section defended the state (as an employer) in numerous workers' compensation matters before the Alaska Workers' Compensation Board and the Alaska Workers' Compensation Appeals Commission, and defended the state, its agencies, and its employees in numerous state and federal court tort cases.

- Transportation. Section attorneys defended multiple contractor claims filed against the Department of Transportation and Public Facilities. Included among the larger cases were claims arising from road construction and airport projects in the Central and Southeast regions.

Promoting and Defending Good Governance

- Labor and State Affairs. Advised the Office of the Lieutenant Governor on issues, litigation, legislations and regulations stemming from the 2020 election cycle and implementation of the ranked choice voting initiative.
- Labor and State Affairs. Along with other attorneys in the department, advised the Office of the Governor, the Department of Administration, the Department of Commerce, Community, and Economic Development, the Office of Management and Budget, and other agencies regarding application of the Disaster Act during the pandemic and the distribution of federal funds to the state to mitigate impacts from the pandemic.
- Opinions, Appeals and Ethics. The section promoted and enforced compliance with the Alaska Executive Branch Ethics Act by advising individuals and agencies on ethics questions, presenting ethics trainings, drafting ethics opinions and memoranda of advice, and investigating and resolving ethics complaints against former or current state employees.
- Legislation and Regulations. Coordinated and drafted legislative bills on behalf of the administration for the first year of the 32nd legislative session, including four special sessions.

Key Department Challenges

Criminal Division

The two greatest challenges for the Criminal Division have been, and continue to be, the growing backlog of cases resulting from suspending jury trials due to COVID-19 and addressing the division’s recruitment and retention challenges. The number of pending criminal cases in the court system has almost doubled since 2018, with the greatest growth seen during the pandemic.

Pending Criminal Cases 2018-2021

Case Type	9/11/2018	9/11/2019	9/11/2020	9/11/2021
Felony	4,514	5,145	6,486	7,328
Misdemeanor	7,872	9,593	12,564	12,756
Total	12,386	14,738	19,050	20,084

The suspension of jury trials not only means jury trials do not occur, but also means many cases that normally resolve via plea negotiations have stalled without the threat of a jury trial looming in the near future. The resumption of jury trials is expected to occur in early CY2022 and this will certainly help decrease the number the cases pending, but it is unlikely the mere resumption of jury trials will be sufficient to return the numbers of pending criminal cases to pre-pandemic levels anytime soon. This equals delayed justice for victims and greater caseloads for prosecutors who were already struggling under very high caseloads.

While the Criminal Division has been making efforts to improve recruitment and retention, the backlog of cases due to suspension of jury trials only exasperates one of the Criminal Division’s challenges in recruitment and retention: high workloads and burnout. Though high workloads and burnout are not the only issues the division faces in recruitment and retention, they are significant factors.

Civil Division

Protecting children, vulnerable adults and consumers is at the core of the Civil Division's mission to protect both the physical and financial well-being of Alaskans.

- Child Protection. Shrinking division resources and increasing caseloads on a statewide basis are presenting significant challenges for the section. High attorney caseloads and shrinking resources increase costs to the

state and lead to longer stays in foster care for children who could otherwise find permanency in their "forever home." The limited resources and growing caseloads could also negatively impact the amount of federal Title IV-E dollars the state is entitled to receive in reimbursement for eligible legal services performed in CINA cases, thereby increasing the amount of general funds needed to perform the work.

- Human Services. Attorney caseloads continue to increase each year, mainly because Alaska has one of the fastest growing aging populations in the nation. In addition, the section anticipates a significant increase in the number and complexity of regulation projects designed to assist in creating additional efficiencies in the administration of all DHSS programs. These projects are expected to generate litigation as change to programs and funding streams are implemented in the coming fiscal year.
- Consumer Protection. Alaska is a target state for many types of consumer fraud. Under the authority of the Consumer Protection Act (AS 45.50.471 et seq.), the state section investigates and brings enforcement action against businesses that engage in unfair or deceptive trade practices. Because of vacancies and current budget constraints, the department's consumer protection enforcement capacity has been significantly limited in the last few years. Collaboration between the Commercial and Fair Business section and the Special Litigation section to increase its consumer protection enforcement functions continues.

Fostering the Conditions for Economic Opportunity and Responsible Development and Use of Natural Resources

- Environmental Law. Position reductions have limited the ability to pursue cleanup of "lingering contaminated sites" where there is no responsible party undertaking a cleanup. Another challenge is engaging federal agencies on matters and decisions that affect the state's interests.
- Natural Resources. Defending the state's interests and goals from increasing restrictions under federal statutes and regulations continues to expand the section's caseload and requires strategically selecting the cases for litigation that are most likely to achieve the state's goals.

Protecting the Fiscal Integrity of the State

- Labor and State Affairs. Prior to the pandemic, the section's attorneys already had full workloads, and the pandemic has only increased these workloads and required a lot of urgent work in areas such as emergency regulations, health mandates, administrative orders, etc. In addition, the section suffers from a lack of deep experience due to retirements and turnover. Recruitment continues to be difficult, producing only small pools of applicants and creating the need to advertise the position multiple times before a qualified candidate can be identified.
- Natural Resources. The section is pursuing hundreds of millions of dollars in past-due taxes, interest and penalties owed by oil and gas producers and other corporate taxpayers. Representing the Department of Natural Resources in royalty disputes and negotiations to ensure that the state receives the appropriate share of royalties and net profit share from production continues to be a challenge with reduced staffing.
- Natural Resources. Defending the state's interests and goals from increasing restrictions under federal statutes and regulations as well as lawsuits from environmental groups to broaden the reach of federal laws continues to expand the section's caseload. In addition, attorney turnover and a difficult recruiting environment coupled with a high volume of work has negatively impacted the section's ability to deliver timely client services for non-oil and gas programs.

Promoting and Defending Good Governance

- Information and Project Support. The section's key challenges include continuing (1) to respond to and to advise and train agencies on responding to public records requests, (2) to advise and train agencies on protecting privileged and confidential information, (3) to make e-Discovery and legal hold tools available and to assist with e-Discovery and the implementation of legal holds, (4) to operate and train employees on the division's matter-management system, and (5) to advise agencies on records retention and Open Meetings Act issues.

- Opinions, Appeals and Ethics. A key challenge for the section is to lend its expertise in appellate briefing and argument to all Civil Division sections, given the volume of appeals to which the state is a party. At any given time, the Civil Division has between 100 and 150 civil appeals pending, 25-30 of which are child protection cases involving child abuse and neglect. The section directly handles all of the child protection appeals statewide, as well as all appeals of civil commitments statewide. The section also directly handles appeals in cases that concern constitutional and legal issues of particular import.

Significant Changes in Results to be Delivered in FY2023

The department is continuously assessing how it can better provide legal services to state agencies and prosecute criminal activity in order to increase public safety. In light of the current environment, the department has made every effort to redirect and consolidate available resources in order to ensure efficiency while preserving effectiveness.

The Criminal Division's significant changes in results for FY2022 will hopefully address the division's biggest challenges. The division hopes jury trials will resume that should help decrease a crushing workload, even if that resumption cannot completely address the high caseloads. The Criminal Division is also working to improve its recruitment and retention for both existing employees and for the prosecutors and staff add in FY2022. Increased training for both new and existing prosecutors and staff remains a focus of the division. In the meantime, the reduced crime rate over the last several years with the increased filings in criminal cases bodes well for Alaska if the same level prosecution service remains.

Recent changes to the Civil Division include increasing the number of attorneys working primarily with DNR on challenges to actions of the federal government that reduce Alaska's ability to develop natural resources. The Civil Division is also strengthening its legislation and regulations work, to streamline drafting and review of proposed and passed state laws.

Contact Information	
Commissioner: Treg Taylor Phone: (907) 269-5100 E-mail: treg.taylor@alaska.gov	Administrative Services Director: Amber LeBlanc Phone: (907) 465-3673 E-mail: amber.leblanc@alaska.gov

Summary of Department Budget Changes by RDU

From FY2022 Management Plan to FY2023 Governor

All dollars shown in thousands

	<u>Unrestricted Gen (UGF)</u>	<u>Designated Gen (DGF)</u>	<u>Other Funds</u>	<u>Federal Funds</u>	<u>Total Funds</u>
FY2022 Management Plan	61,953.2	2,776.5	32,488.3	2,035.5	99,253.5
Adjustments which get you to start of year:					
-Civil Division	4,000.0	0.0	0.0	0.0	4,000.0
One-time items:					
-Civil Division	-4,000.0	0.0	0.0	0.0	-4,000.0
Adjustments which continue current level of service:					
-Criminal Division	-802.0	0.0	-68.5	12.0	-858.5
-Civil Division	-1,077.9	-39.0	208.8	0.0	-908.1
-Administration and Support	-57.7	0.0	-6.7	0.0	-64.4
-Agency Unallocated	261.1	9.2	133.7	8.7	412.7
Proposed budget increases:					
-Criminal Division	749.8	0.0	0.0	0.0	749.8
Proposed budget decreases:					
-Criminal Division	0.0	0.0	-104.2	0.0	-104.2
FY2023 Governor	61,026.5	2,746.7	32,651.4	2,056.2	98,480.8

Department Totals
Department of Law

Description	FY2021 Actuals	FY2022 Conference Committee	FY2022 Authorized	FY2022 Management Plan	FY2023 Governor	FY2022 Management Plan vs FY2023 Governor	
Department Totals	84,786.7	95,273.5	99,253.5	99,253.5	98,480.8	-772.7	-0.8%
Objects of Expenditure:							
71000 Personal Services	66,044.6	76,029.6	76,029.6	76,241.6	75,116.2	-1,125.4	-1.5%
72000 Travel	314.0	1,393.9	1,393.9	1,393.9	1,418.9	25.0	
73000 Services	17,322.2	16,902.6	20,882.6	20,670.6	20,973.3	302.7	1.5%
74000 Commodities	932.8	923.8	923.8	923.8	948.8	25.0	2.7%
75000 Capital Outlay	173.1	23.6	23.6	23.6	23.6	0.0	0.0%
77000 Grants, Benefits	0.0	0.0	0.0	0.0	0.0	0.0	0.0%
78000 Miscellaneous	0.0	0.0	0.0	0.0	0.0	0.0	0.0%
Funding Source:							
1002 Fed Rcpts (Fed)	1,594.9	2,035.5	2,035.5	2,035.5	2,056.2	20.7	1.0%
1003 G/F Match (UGF)	508.8	542.5	542.5	542.5	545.3	2.8	0.5%
1004 Gen Fund (UGF)	50,988.6	57,330.6	61,310.6	61,310.6	60,381.1	-929.5	-1.5%
1005 GF/Prgm (DGF)	12.2	196.0	196.0	196.0	196.3	0.3	0.2%
1007 I/A Rcpts (Other)	24,806.1	27,506.9	27,506.9	27,506.9	27,697.1	190.2	0.7%
1037 GF/MH (UGF)	0.0	100.1	100.1	100.1	100.1	0.0	0.0%
1055 IA/OIL HAZ (Other)	259.7	472.0	472.0	472.0	477.3	5.3	1.1%
1061 CIP Rcpts (Other)	335.5	505.8	505.8	505.8	506.5	0.7	0.1%
1105 PFund Rcpt (Other)	2,619.1	2,687.7	2,687.7	2,687.7	2,708.8	21.1	0.8%
1108 Stat Desig (Other)	1,085.0	1,315.9	1,315.9	1,315.9	1,261.7	-54.2	-4.1%
1141 RCA Rcpts (DGF)	2,391.1	2,475.7	2,475.7	2,475.7	2,444.9	-30.8	-1.2%
1168 Tob Ed/Ces (DGF)	102.8	104.8	104.8	104.8	105.5	0.7	0.7%
1236 AK LNG I/A (Other)	82.9	0.0	0.0	0.0	0.0	0.0	0.0%
Totals:							
Unrestricted Gen (UGF)	51,497.4	57,973.2	61,953.2	61,953.2	61,026.5	-926.7	-1.5%
Designated Gen (DGF)	2,506.1	2,776.5	2,776.5	2,776.5	2,746.7	-29.8	-1.1%
Other Funds	29,188.3	32,488.3	32,488.3	32,488.3	32,651.4	163.1	0.5%
Federal Funds	1,594.9	2,035.5	2,035.5	2,035.5	2,056.2	20.7	1.0%
Positions:							
Permanent Full Time	533	549	549	551	550	-1	-0.2%
Permanent Part Time	0	0	0	0	0	0	0.0%
Non Permanent	0	0	0	0	0	0	0.0%

Component Summary Unrestricted General Funds Only
Department of Law

Results Delivery Unit/ Component	FY2021 Actuals	FY2022 Conference Committee	FY2022 Authorized	FY2022 Management Plan	FY2023 Governor	FY2022 Management Plan vs FY2023 Governor	
Criminal Division							
First Judicial District	2,254.8	2,755.1	2,755.1	2,755.1	2,794.2	39.1	1.4%
Second Judicial District	1,631.8	2,594.7	2,594.7	2,669.7	2,733.5	63.8	2.4%
Third Judicial: Anchorage	8,196.7	8,588.9	8,588.9	8,654.1	8,619.0	-35.1	-0.4%
Third JD: Outside Anchorage	5,544.7	6,267.2	6,267.2	6,267.2	6,263.7	-3.5	-0.1%
Fourth Judicial District	6,112.1	6,807.0	6,807.0	6,807.0	6,819.3	12.3	0.2%
Criminal Justice Litigation	1,757.1	2,461.0	2,461.0	2,309.2	2,253.4	-55.8	-2.4%
Criminal Appeals/Special Lit	5,238.0	5,530.0	5,530.0	5,541.6	5,468.6	-73.0	-1.3%
RDU Totals:	30,735.2	35,003.9	35,003.9	35,003.9	34,951.7	-52.2	-0.1%
Civil Division (Excludes Janus)							
Dep. Attny General's Office	1,943.8	279.3	4,279.3	4,279.3	4,273.4	-5.9	-0.1%
Child Protection	6,083.5	5,568.5	5,568.5	5,568.5	5,381.1	-187.4	-3.4%
Commercial and Fair Business	466.5	705.0	705.0	705.0	613.8	-91.2	-12.9%
Environmental Law	161.8	764.9	764.9	764.9	717.2	-47.7	-6.2%
Human Services	1,959.0	1,789.5	1,789.5	1,789.5	1,701.3	-88.2	-4.9%
Labor and State Affairs	4,082.7	1,670.8	1,670.8	1,600.2	1,488.9	-111.3	-7.0%
Legislation/Regulations	912.9	1,141.6	1,141.6	1,329.3	1,287.6	-41.7	-3.1%
Natural Resources	2,270.6	4,099.9	4,099.9	4,236.0	4,125.4	-110.6	-2.6%
Opinions, Appeals and Ethics	513.0	1,406.0	1,406.0	1,406.0	1,347.1	-58.9	-4.2%
Reg Affairs Public Advocacy	1.6	458.1	458.1	458.1	456.0	-2.1	-0.5%
Special Litigation	4.8	1,492.7	1,492.7	1,239.5	1,198.9	-40.6	-3.3%
Information and Project Support	47.1	519.4	519.4	519.4	457.6	-61.8	-11.9%
Torts and Workers' Compensation	10.6	219.6	219.6	219.6	75.4	-144.2	-65.7%
Transportation Section	4.6	112.5	112.5	112.5	26.2	-86.3	-76.7%
RDU Totals:	18,462.5	20,227.8	24,227.8	24,227.8	23,149.9	-1,077.9	-4.4%
Administration and Support							
Office of the Attorney General	344.3	551.6	551.6	551.6	534.6	-17.0	-3.1%
Administrative Services	1,109.1	1,323.6	1,323.6	1,323.6	1,282.9	-40.7	-3.1%
Dept of Law State Facilities Rnt	846.3	846.3	846.3	846.3	846.3	0.0	0.0%
RDU Totals:	2,299.7	2,721.5	2,721.5	2,721.5	2,663.8	-57.7	-2.1%
Legal Contracts Janus v AFSCME Decision							
Legal Contracts	0.0	20.0	0.0	0.0	0.0	0.0	0.0%
RDU Totals:	0.0	20.0	0.0	0.0	0.0	0.0	0.0%
Agency Unallocated							
Unallocated Rates Adjustment	0.0	0.0	0.0	0.0	261.1	261.1	100.0%
RDU Totals:	0.0	0.0	0.0	0.0	261.1	261.1	100.0%
Unrestricted Gen (UGF):	51,497.4	57,973.2	61,953.2	61,953.2	61,026.5	-926.7	-1.5%
Designated Gen (DGF):	0.0	0.0	0.0	0.0	0.0	0.0	0.0%
Other Funds:	0.0	0.0	0.0	0.0	0.0	0.0	0.0%
Federal Funds:	0.0	0.0	0.0	0.0	0.0	0.0	0.0%
Total Funds:	51,497.4	57,973.2	61,953.2	61,953.2	61,026.5	-926.7	-1.5%

Component Summary All Funds
Department of Law

Results Delivery Unit/ Component	FY2021 Actuals	FY2022 Conference Committee	FY2022 Authorized	FY2022 Management Plan	FY2023 Governor	FY2022 Management Plan vs FY2023 Governor	
Criminal Division							
First Judicial District	2,287.6	2,813.8	2,813.8	2,813.8	2,836.2	22.4	0.8%
Second Judicial District	1,798.3	2,918.7	2,918.7	2,993.7	3,051.2	57.5	1.9%
Third Judicial: Anchorage	8,316.6	8,871.5	8,871.5	8,936.7	8,896.1	-40.6	-0.5%
Third JD: Outside Anchorage	5,686.1	6,436.8	6,436.8	6,436.8	6,412.0	-24.8	-0.4%
Fourth Judicial District	6,465.0	7,277.0	7,277.0	7,277.0	7,257.1	-19.9	-0.3%
Criminal Justice Litigation	2,148.5	3,145.2	3,145.2	2,993.4	2,837.5	-155.9	-5.2%
Criminal Appeals/Special Lit	7,938.0	8,901.5	8,901.5	8,913.1	8,861.5	-51.6	-0.6%
RDU Totals:	34,640.1	40,364.5	40,364.5	40,364.5	40,151.6	-212.9	-0.5%
Civil Division (Excludes Janus)							
Dep. Attny General's Office	1,943.8	299.3	4,299.3	4,299.3	4,293.4	-5.9	-0.1%
Child Protection	9,763.4	7,863.6	7,863.6	7,813.6	7,645.5	-168.1	-2.2%
Commercial and Fair Business	4,710.9	5,557.9	5,557.9	4,731.8	4,889.3	157.5	3.3%
Environmental Law	1,161.3	2,006.7	2,006.7	2,006.7	1,970.1	-36.6	-1.8%
Human Services	3,253.8	3,436.7	3,436.7	3,436.7	3,360.2	-76.5	-2.2%
Labor and State Affairs	6,978.1	4,839.4	4,839.4	4,698.3	4,610.2	-88.1	-1.9%
Legislation/Regulations	1,136.4	1,463.7	1,463.7	1,751.2	1,713.4	-37.8	-2.2%
Natural Resources	6,255.8	8,013.6	8,013.6	8,183.7	8,092.2	-91.5	-1.1%
Opinions, Appeals and Ethics	513.0	2,384.4	2,384.4	2,434.4	2,386.2	-48.2	-2.0%
Reg Affairs Public Advocacy	2,392.7	2,933.8	2,933.8	2,933.8	2,892.2	-41.6	-1.4%
Special Litigation	4.8	1,919.1	1,919.1	1,910.8	1,878.0	-32.8	-1.7%
Information and Project Support	2,109.6	1,970.8	1,970.8	2,214.8	2,165.7	-49.1	-2.2%
Torts and Workers' Compensation	3,800.6	4,593.6	4,593.6	4,519.7	4,420.3	-99.4	-2.2%
Transportation Section	1,986.2	2,747.9	2,747.9	3,095.7	2,805.7	-290.0	-9.4%
RDU Totals:	46,010.4	50,030.5	54,030.5	54,030.5	53,122.4	-908.1	-1.7%
Administration and Support							
Office of the Attorney General	1,002.8	740.1	740.1	740.1	725.4	-14.7	-2.0%
Administrative Services	2,287.1	3,272.1	3,272.1	3,272.1	3,222.4	-49.7	-1.5%
Dept of Law State Facilities Rnt	846.3	846.3	846.3	846.3	846.3	0.0	0.0%
RDU Totals:	4,136.2	4,858.5	4,858.5	4,858.5	4,794.1	-64.4	-1.3%
Legal Contracts Janus v AFSCME Decision							
Legal Contracts	0.0	20.0	0.0	0.0	0.0	0.0	0.0%
RDU Totals:	0.0	20.0	0.0	0.0	0.0	0.0	0.0%
Agency Unallocated							
Unallocated Rates Adjustment	0.0	0.0	0.0	0.0	412.7	412.7	100.0%
RDU Totals:	0.0	0.0	0.0	0.0	412.7	412.7	100.0%
Unrestricted Gen (UGF):	51,497.4	57,973.2	61,953.2	61,953.2	61,026.5	-926.7	-1.5%
Designated Gen (DGF):	2,506.1	2,776.5	2,776.5	2,776.5	2,746.7	-29.8	-1.1%
Other Funds:	29,188.3	32,488.3	32,488.3	32,488.3	32,651.4	163.1	0.5%
Federal Funds:	1,594.9	2,035.5	2,035.5	2,035.5	2,056.2	20.7	1.0%
Total Funds:	84,786.7	95,273.5	99,253.5	99,253.5	98,480.8	-772.7	-0.8%

Component Summary All Funds
Department of Law

Results Delivery Unit/ Component	FY2021 Actuals	FY2022 Conference Committee	FY2022 Authorized	FY2022 Management Plan	FY2023 Governor	FY2022 Management Plan vs FY2023 Governor	
Permanent Full Time:	533	549	549	551	550	-1	-0.2%
Permanent Part Time:	0	0	0	0	0	0	0.0%
Non Permanent:	0	0	0	0	0	0	0.0%
Total Positions:	533	549	549	551	550	-1	-0.2%

Inter-Agency Revenue Summary
Department of Law
Revenue Type Inter-Agency Receipts Only

Scenario: FY2023 Governor (18673)

IRIS Revenue Type	IRIS Revenue Source Code	Component	Total
Department of Law Totals:			28,357.5
5007 I/A Rcpts	5301 Inter-Agency Receipts	Admin - Department-wide	4,494.9
5007 I/A Rcpts	5301 Inter-Agency Receipts	Commerce - Department-wide	2,611.4
5007 I/A Rcpts	5301 Inter-Agency Receipts	Correct - Department-wide	505.0
5007 I/A Rcpts	5301 Inter-Agency Receipts	Courts - Department-wide	700.6
5007 I/A Rcpts	5301 Inter-Agency Receipts	E&ED - Department-wide	607.0
5007 I/A Rcpts	5301 Inter-Agency Receipts	EnvCon - Department-wide	1,029.8
5007 I/A Rcpts	5301 Inter-Agency Receipts	FishGm - Department-wide	285.8
5007 I/A Rcpts	5301 Inter-Agency Receipts	Gov - Department-wide	65.0
5007 I/A Rcpts	5301 Inter-Agency Receipts	Health - Department-wide	4,143.3
5007 I/A Rcpts	5301 Inter-Agency Receipts	Labor - Department-wide	560.0
5007 I/A Rcpts	5301 Inter-Agency Receipts	Law - Commercial and Fair Business (2717)	225.0
5007 I/A Rcpts	5301 Inter-Agency Receipts	Law - Criminal Justice Litigation (2202)	10.0
5007 I/A Rcpts	5301 Inter-Agency Receipts	Law - Dep. Attny General's Office (2205)	2,578.0
5007 I/A Rcpts	5301 Inter-Agency Receipts	Law - Office of the Attorney General (2162)	1,833.3
5007 I/A Rcpts	5301 Inter-Agency Receipts	Law - Opinions, Appeals and Ethics (2716)	1,039.1
5007 I/A Rcpts	5301 Inter-Agency Receipts	M&VA - Department-wide	20.0
5007 I/A Rcpts	5301 Inter-Agency Receipts	NatRes - Department-wide	955.0
5007 I/A Rcpts	5301 Inter-Agency Receipts	PubSaf - Department-wide	1,431.9
5007 I/A Rcpts	5301 Inter-Agency Receipts	Rev - Department-wide	1,997.4
5007 I/A Rcpts	5301 Inter-Agency Receipts	Trans - Department-wide	2,589.9
5055 IA/OIL HAZ	5391 Oil and Hazardous Waste Inter-Agency	EnvCon - Department-wide	475.5
5061 CIP Rcpts	5351 Capital Improvement Project Inter-Agency	NatRes - Department-wide	49.6
5061 CIP Rcpts	5351 Capital Improvement Project Inter-Agency	Trans - Department-wide	150.0
RDU: Criminal Division (33)			2,889.9
5007 I/A Rcpts	5301 Inter-Agency Receipts	Courts - Department-wide	670.6
5007 I/A Rcpts	5301 Inter-Agency Receipts	EnvCon - Department-wide	182.4
5007 I/A Rcpts	5301 Inter-Agency Receipts	Health - Department-wide	170.0
5007 I/A Rcpts	5301 Inter-Agency Receipts	Law - Commercial and Fair Business (2717)	225.0
5007 I/A Rcpts	5301 Inter-Agency Receipts	PubSaf - Department-wide	1,416.9
5007 I/A Rcpts	5301 Inter-Agency Receipts	Rev - Department-wide	225.0
Component: First Judicial District (2198)			41.0
5007 I/A Rcpts	5301 Inter-Agency Receipts	Courts - Department-wide	41.0
Component: Third Judicial District: Anchorage (2261)			266.1
5007 I/A Rcpts	5301 Inter-Agency Receipts	Courts - Department-wide	266.1
Component: Third Judicial District: Outside Anchorage (2279)			142.3
5007 I/A Rcpts	5301 Inter-Agency Receipts	Courts - Department-wide	142.3
Component: Fourth Judicial District (2201)			430.8
5007 I/A Rcpts	5301 Inter-Agency Receipts	Courts - Department-wide	221.2
5007 I/A Rcpts	5301 Inter-Agency Receipts	PubSaf - Department-wide	209.6
Component: Criminal Justice Litigation (2202)			687.3
5007 I/A Rcpts	5301 Inter-Agency Receipts	PubSaf - Department-wide	687.3
Component: Criminal Appeals/Special Litigation (2203)			1,322.4
5007 I/A Rcpts	5301 Inter-Agency Receipts	EnvCon - Department-wide	182.4
5007 I/A Rcpts	5301 Inter-Agency Receipts	Health - Department-wide	170.0
5007 I/A Rcpts	5301 Inter-Agency Receipts	Law - Commercial and Fair Business (2717)	225.0
5007 I/A Rcpts	5301 Inter-Agency Receipts	PubSaf - Department-wide	520.0
5007 I/A Rcpts	5301 Inter-Agency Receipts	Rev - Department-wide	225.0
RDU: Civil Division (Excludes Janus) (35)			23,443.5
5007 I/A Rcpts	5301 Inter-Agency Receipts	Admin - Department-wide	4,494.9
5007 I/A Rcpts	5301 Inter-Agency Receipts	Commerce - Department-wide	2,611.4
5007 I/A Rcpts	5301 Inter-Agency Receipts	Correct - Department-wide	505.0
5007 I/A Rcpts	5301 Inter-Agency Receipts	Courts - Department-wide	30.0
5007 I/A Rcpts	5301 Inter-Agency Receipts	E&ED - Department-wide	607.0
5007 I/A Rcpts	5301 Inter-Agency Receipts	EnvCon - Department-wide	847.4
5007 I/A Rcpts	5301 Inter-Agency Receipts	FishGm - Department-wide	285.8
5007 I/A Rcpts	5301 Inter-Agency Receipts	Gov - Department-wide	65.0
5007 I/A Rcpts	5301 Inter-Agency Receipts	Health - Department-wide	3,973.3

Inter-Agency Revenue Summary
Department of Law
Revenue Type Inter-Agency Receipts Only

Scenario: FY2023 Governor (18673)

IRIS Revenue Type	IRIS Revenue Source Code	Component	Total
5007 I/A Rcpts	5301 Inter-Agency Receipts	Labor - Department-wide	560.0
5007 I/A Rcpts	5301 Inter-Agency Receipts	Law - Criminal Justice Litigation (2202)	10.0
5007 I/A Rcpts	5301 Inter-Agency Receipts	Law - Dep. Attny General's Office (2205)	2,387.2
5007 I/A Rcpts	5301 Inter-Agency Receipts	Law - Opinions, Appeals and Ethics (2716)	1,039.1
5007 I/A Rcpts	5301 Inter-Agency Receipts	M&VA - Department-wide	20.0
5007 I/A Rcpts	5301 Inter-Agency Receipts	NatRes - Department-wide	955.0
5007 I/A Rcpts	5301 Inter-Agency Receipts	PubSaf - Department-wide	15.0
5007 I/A Rcpts	5301 Inter-Agency Receipts	Rev - Department-wide	1,772.4
5007 I/A Rcpts	5301 Inter-Agency Receipts	Trans - Department-wide	2,589.9
5055 IA/OIL HAZ	5391 Oil and Hazardous Waste Inter-Agency	EnvCon - Department-wide	475.5
5061 CIP Rcpts	5351 Capital Improvement Project Inter-Agency	NatRes - Department-wide	49.6
5061 CIP Rcpts	5351 Capital Improvement Project Inter-Agency	Trans - Department-wide	150.0
Component: Deputy Attorney General's Office (2205)			10.0
5007 I/A Rcpts	5301 Inter-Agency Receipts	Law - Criminal Justice Litigation (2202)	10.0
Component: Child Protection (2961)			2,264.4
5007 I/A Rcpts	5301 Inter-Agency Receipts	Health - Department-wide	2,264.4
Component: Commercial and Fair Business (2717)			3,093.4
5007 I/A Rcpts	5301 Inter-Agency Receipts	Admin - Department-wide	5.0
5007 I/A Rcpts	5301 Inter-Agency Receipts	Commerce - Department-wide	1,405.0
5007 I/A Rcpts	5301 Inter-Agency Receipts	E&ED - Department-wide	142.0
5007 I/A Rcpts	5301 Inter-Agency Receipts	NatRes - Department-wide	15.0
5007 I/A Rcpts	5301 Inter-Agency Receipts	Rev - Department-wide	1,526.4
Component: Environmental Law (2092)			1,252.9
5007 I/A Rcpts	5301 Inter-Agency Receipts	EnvCon - Department-wide	777.4
5055 IA/OIL HAZ	5391 Oil and Hazardous Waste Inter-Agency	EnvCon - Department-wide	475.5
Component: Human Services (2962)			1,658.9
5007 I/A Rcpts	5301 Inter-Agency Receipts	Health - Department-wide	1,658.9
Component: Labor and State Affairs (2718)			2,921.3
5007 I/A Rcpts	5301 Inter-Agency Receipts	Admin - Department-wide	630.0
5007 I/A Rcpts	5301 Inter-Agency Receipts	Commerce - Department-wide	1,045.3
5007 I/A Rcpts	5301 Inter-Agency Receipts	Courts - Department-wide	30.0
5007 I/A Rcpts	5301 Inter-Agency Receipts	E&ED - Department-wide	445.0
5007 I/A Rcpts	5301 Inter-Agency Receipts	Labor - Department-wide	550.0
5007 I/A Rcpts	5301 Inter-Agency Receipts	M&VA - Department-wide	15.0
5007 I/A Rcpts	5301 Inter-Agency Receipts	Rev - Department-wide	206.0
Component: Legislation/Regulations (2209)			425.8
5007 I/A Rcpts	5301 Inter-Agency Receipts	Admin - Department-wide	15.0
5007 I/A Rcpts	5301 Inter-Agency Receipts	Commerce - Department-wide	100.0
5007 I/A Rcpts	5301 Inter-Agency Receipts	Correct - Department-wide	5.0
5007 I/A Rcpts	5301 Inter-Agency Receipts	E&ED - Department-wide	20.0
5007 I/A Rcpts	5301 Inter-Agency Receipts	EnvCon - Department-wide	70.0
5007 I/A Rcpts	5301 Inter-Agency Receipts	FishGm - Department-wide	75.8
5007 I/A Rcpts	5301 Inter-Agency Receipts	Gov - Department-wide	15.0
5007 I/A Rcpts	5301 Inter-Agency Receipts	Health - Department-wide	50.0
5007 I/A Rcpts	5301 Inter-Agency Receipts	Labor - Department-wide	10.0
5007 I/A Rcpts	5301 Inter-Agency Receipts	M&VA - Department-wide	5.0
5007 I/A Rcpts	5301 Inter-Agency Receipts	NatRes - Department-wide	20.0
5007 I/A Rcpts	5301 Inter-Agency Receipts	PubSaf - Department-wide	15.0
5007 I/A Rcpts	5301 Inter-Agency Receipts	Rev - Department-wide	15.0
5007 I/A Rcpts	5301 Inter-Agency Receipts	Trans - Department-wide	10.0
Component: Natural Resources (2212)			1,266.1
5007 I/A Rcpts	5301 Inter-Agency Receipts	Commerce - Department-wide	61.1
5007 I/A Rcpts	5301 Inter-Agency Receipts	FishGm - Department-wide	210.0
5007 I/A Rcpts	5301 Inter-Agency Receipts	Gov - Department-wide	50.0
5007 I/A Rcpts	5301 Inter-Agency Receipts	NatRes - Department-wide	920.0
5007 I/A Rcpts	5301 Inter-Agency Receipts	Rev - Department-wide	25.0
Component: Opinions, Appeals and Ethics (2716)			1,039.1
5007 I/A Rcpts	5301 Inter-Agency Receipts	Law - Opinions, Appeals and Ethics (2716)	1,039.1
Component: Special Litigation (2213)			679.1

Inter-Agency Revenue Summary
Department of Law
Revenue Type Inter-Agency Receipts Only

Scenario: FY2023 Governor (18673)

IRIS Revenue Type	IRIS Revenue Source Code	Component	Total
5007 I/A Rcpts	5301 Inter-Agency Receipts	Law - Dep. Attny General's Office (2205)	679.1
Component: Information and Project Support (2258)			1,708.1
5007 I/A Rcpts	5301 Inter-Agency Receipts	Law - Dep. Attny General's Office (2205)	1,708.1
Component: Torts & Workers' Compensation (2719)			4,344.9
5007 I/A Rcpts	5301 Inter-Agency Receipts	Admin - Department-wide	3,844.9
5007 I/A Rcpts	5301 Inter-Agency Receipts	Correct - Department-wide	500.0
Component: Transportation Section (2214)			2,779.5
5007 I/A Rcpts	5301 Inter-Agency Receipts	Trans - Department-wide	2,579.9
5061 CIP Rcpts	5351 Capital Improvement Project Inter-Agency	NatRes - Department-wide	49.6
5061 CIP Rcpts	5351 Capital Improvement Project Inter-Agency	Trans - Department-wide	150.0
RDU: Administration and Support (280)			2,024.1
5007 I/A Rcpts	5301 Inter-Agency Receipts	Law - Dep. Attny General's Office (2205)	190.8
5007 I/A Rcpts	5301 Inter-Agency Receipts	Law - Office of the Attorney General (2162)	1,833.3
Component: Office of the Attorney General (2162)			190.8
5007 I/A Rcpts	5301 Inter-Agency Receipts	Law - Dep. Attny General's Office (2205)	190.8
Component: Administrative Services (2164)			1,833.3
5007 I/A Rcpts	5301 Inter-Agency Receipts	Law - Office of the Attorney General (2162)	1,833.3

**State of Alaska
FY2023 Governor's Operating Budget**

**Department of Law
Criminal Division
Results Delivery Unit Budget Summary**

Criminal Division Results Delivery Unit

Contribution to Department's Mission

The mission of the Criminal Division is to seek justice, promote public safety, and further public respect for government through prompt, effective, and compassionate prosecution of cases. The Criminal Division will prosecute cases in a manner that advocates for the interests of the public, including victims, respects law enforcement agencies, responsibly stewards public resources, and holds offenders accountable, while at the same time protecting the constitutional and legal rights of the accused.

Results

(Additional performance information is available on the web at <https://omb.alaska.gov/results>.)

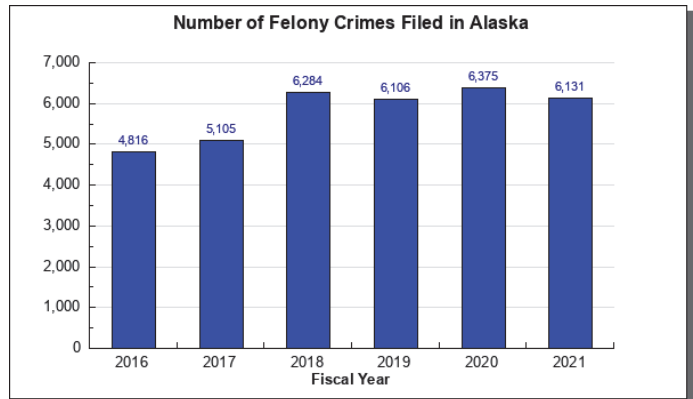
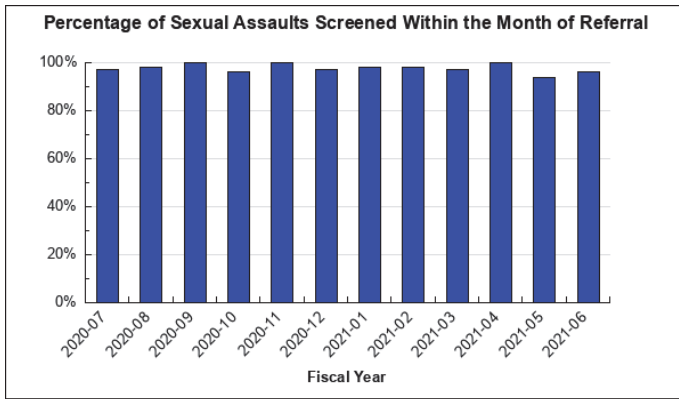

Measures by Core Service

(Additional performance information is available on the web at <https://omb.alaska.gov/results>.)

Major RDU Accomplishments in 2021

Protecting the Safety and Physical and Financial Well-being of Alaskans

Criminal Division

The impacts of COVID-19 dominated the landscape of the criminal justice system in FY2021. Despite the global pandemic, the Criminal Division kept its personnel healthy and continued its mission. The division nimbly adapted its offices to manage the health of the employees. Over 50% of the division's employees transitioned to work from home while those that remained in the offices followed health and safety protocols, which allowed the division to avoid any significant outbreaks amongst employees that could have otherwise interfered with the division's ability to achieve its mission of protecting Alaskans.

The division maintained its level of felony filings despite the pandemic and its impact on the ability to safely work in the office. The division's felony filings, tracked by fiscal year, continued at a robust level comparable to the previous three years FY 2018-2020. FY2018-2020 saw significant increases in filings compared to previous years and the crime rate began dropping from its high in FY2017. Alaska's crime rate fell for the third year in a row in CY2020 according the Department of Public Safety's "Crime in Alaska 2020" report. From CY2019 to CY2020 the overall crime rate dropped 18.5%, for an overall 29.5% decrease in the crime rate since CY2017. The increase in felony filings at the same time as a drop in the crime rates provides positive results in public safety for Alaska. This bodes well for public safety if the Criminal Division is able to maintain its current level of resources.

The division also managed to conduct a handful of jury trials during a very challenging period of the pandemic (July 2020 – May 2021) when almost all jury trials were suspended. Those cases focused on sex crimes and domestic

violence crimes. Jury trials are a key component to the criminal justice system as the threat of an imminent trial incentivizes defendants to resolve their cases to avoid sentences that might be greater if a case proceeded to trial. While it would have been preferable to have conducted more trials during this time frame, health and safety of all participants (jury, judges, lawyers, other court personnel, etc.) did not allow this at the heights of the pandemic. Once trials resumed in June of 2021, the division conducted 70 jury trials over the next two months before jury trials were once again suspend for health and safety reasons.

The division also maintained a high output level, both in quality and quantity, of appellate briefs. This is significant due to the appellate delay issues that have plagued the criminal justice system for the past decade. The delay in processing criminal appeals has grown to point where the courts now routinely grant extensions of time to file briefing by hundreds of days for each case. This means cases on appeal can take over 2-3 years to be decided. The Criminal Division has keep its length of extensions to almost half of the time the defense has been taking.

Key RDU Challenges

The two greatest challenges for the Criminal Division have been, and continue to be, the growing backlog of cases resulting from suspending jury trials due to COVID-19 and addressing the division’s recruitment and retention challenges. The number of pending criminal cases in the court system has almost doubled since 2018, with the greatest growth seen during the pandemic.

Pending Criminal Cases 2018-2021

Case Type	9/11/2018	9/11/2019	9/11/2020	9/11/2021
Felony	4,514	5,145	6,486	7,328
Misdemeanor	7,872	9,593	12,564	12,756
Total	12,386	14,738	19,050	20,084

The suspension of jury trials not only means jury trials do not occur, but also means many cases that normally resolve via plea negotiations have stalled without the threat of a jury trial looming in the near future. The resumption of jury trials is expected to occur in early CY2022 and this will certainly help decrease the number the cases pending, but it is unlikely the mere resumption of jury trials will be sufficient to return the numbers of pending criminal cases to pre-pandemic levels anytime soon. This equals delayed justice for victims and greater caseloads for prosecutors who were already struggling under very high caseloads.

While the Criminal Division has been making efforts to improve recruitment and retention, the backlog of cases due to suspension of jury trials only exasperates one of the Criminal Division’s challenges in recruitment and retention: high workloads and burnout. Though high workloads and burnout are not the only issues the division faces in recruitment and retention, they are significant factors.

Significant Changes in Results to be Delivered in FY2023

The Criminal Division is continuously assessing how it can better prosecute criminal activity in order to increase public safety. The Criminal Division continues to work with stakeholders across the criminal justice field to evaluate, implement and refine changes to criminal law and the criminal justice system. The division will continue to focus resources on the most serious offenders and offenses. The division plans to develop pre-trial diversion programs to repay victims faster for losses or damage, and incentivize treatment for substance addiction. The division continues to work on interfaces with the Alaska Court System and law enforcement agencies around the state to better share resources, including analyzing trends in prosecution data to decrease pre-trial delay, improve communication with victims, eliminate duplicative efforts and reduce errors, and lessen the use of paper files.

The significant changes in results for FY2022 will hopefully address the division’s biggest challenges. The division hopes jury trials will resume that should help decrease a crushing workload, even if that resumption cannot completely address the high caseloads. The Criminal Division is also working to improve its recruitment and retention for both existing employees and for the prosecutors and staff add in FY2022. Increased training for both new and existing prosecutors and staff remains a focus of the division. In the meantime, the reduced crime rate over the last several years with the increased filings in criminal cases bodes well for Alaska if the same level

prosecution service remains.

Contact Information
<p>Contact: John Skidmore, Deputy Attorney General Phone: (907) 269-5100 E-mail: john.skidmore@alaska.gov</p>

**Criminal Division
RDU Financial Summary by Component**

All dollars shown in thousands

	FY2021 Actuals				FY2022 Management Plan				FY2023 Governor			
	UGF+DGF Funds	Other Funds	Federal Funds	Total Funds	UGF+DGF Funds	Other Funds	Federal Funds	Total Funds	UGF+DGF Funds	Other Funds	Federal Funds	Total Funds
Formula Expenditures None.												
Non-Formula Expenditures												
First Judicial District	2,255.2	32.4	0.0	2,287.6	2,756.1	57.7	0.0	2,813.8	2,795.2	41.0	0.0	2,836.2
Second Judicial District	1,631.8	166.5	0.0	1,798.3	2,670.7	323.0	0.0	2,993.7	2,734.5	316.7	0.0	3,051.2
Third Judicial: Anchorage	8,198.2	118.4	0.0	8,316.6	8,665.1	271.6	0.0	8,936.7	8,630.0	266.1	0.0	8,896.1
Third JD: Outside Anchorage	5,549.4	136.7	0.0	5,686.1	6,273.2	163.6	0.0	6,436.8	6,269.7	142.3	0.0	6,412.0
Fourth Judicial District	6,117.0	348.0	0.0	6,465.0	6,814.0	463.0	0.0	7,277.0	6,826.3	430.8	0.0	7,257.1
Criminal Justice Litigation	1,757.1	391.4	0.0	2,148.5	2,310.2	683.2	0.0	2,993.4	2,254.4	583.1	0.0	2,837.5
Criminal Appeals/Special Lit	5,238.7	1,104.4	1,594.9	7,938.0	5,564.6	1,313.0	2,035.5	8,913.1	5,491.6	1,322.4	2,047.5	8,861.5
Totals	30,747.4	2,297.8	1,594.9	34,640.1	35,053.9	3,275.1	2,035.5	40,364.5	35,001.7	3,102.4	2,047.5	40,151.6

Criminal Division
Summary of RDU Budget Changes by Component
From FY2022 Management Plan to FY2023 Governor

All dollars shown in thousands

	<u>Unrestricted</u> <u>Gen (UGF)</u>	<u>Designated</u> <u>Gen (DGF)</u>	<u>Other Funds</u>	<u>Federal</u> <u>Funds</u>	<u>Total Funds</u>
FY2022 Management Plan	35,003.9	50.0	3,275.1	2,035.5	40,364.5
Adjustments which continue current level of service:					
-First Judicial District	-39.6	0.0	-16.7	0.0	-56.3
-Second Judicial District	-57.4	0.0	-6.3	0.0	-63.7
-Third Judicial: Anchorage	-175.1	0.0	-5.5	0.0	-180.6
-Third JD: Outside Anchorage	-122.7	0.0	-21.3	0.0	-144.0
-Fourth Judicial District	-135.7	0.0	-32.2	0.0	-167.9
-Criminal Justice Litigation	-55.8	0.0	4.1	0.0	-51.7
-Criminal Appeals/Special Lit	-215.7	0.0	9.4	12.0	-194.3
Proposed budget increases:					
-First Judicial District	78.7	0.0	0.0	0.0	78.7
-Second Judicial District	121.2	0.0	0.0	0.0	121.2
-Third Judicial: Anchorage	140.0	0.0	0.0	0.0	140.0
-Third JD: Outside Anchorage	119.2	0.0	0.0	0.0	119.2
-Fourth Judicial District	148.0	0.0	0.0	0.0	148.0
-Criminal Appeals/Special Lit	142.7	0.0	0.0	0.0	142.7
Proposed budget decreases:					
-Criminal Justice Litigation	0.0	0.0	-104.2	0.0	-104.2
FY2023 Governor	34,951.7	50.0	3,102.4	2,047.5	40,151.6

**State of Alaska
FY2023 Governor's Operating Budget**

**Department of Law
First Judicial District
Component Budget Summary**

Component: First Judicial District

Contribution to Department's Mission

This component contributes to the department's mission by prosecuting and convicting criminal offenders within the First Judicial District (Southeast Alaska).

Core Services

- Prosecutes violations of state criminal law by both adults and juveniles in the First Judicial District.
- Provides day-to-day advice to state and local law enforcement agencies conducting criminal investigations and serves as legal advisor to grand juries.
- Handles probation revocation actions, all sentence and sufficiency of evidence appeals and most post-conviction relief proceedings.
- Participates in specialized court and probation programs.
- Provides victim-witness assistance services such as: information on court procedures required by statute and the Alaska Constitution; applying for restitution; arrangement of travel and payment for expenses and court-mandated witness fees; assistance with domestic violence orders and violent crimes compensation procedures; and preparation of victims and witnesses to testify in court.

Major Component Accomplishments in 2021

See Accomplishments at RDU level.

Key Component Challenges

See Key Challenges at RDU level.

Significant Changes in Results to be Delivered in FY2023

See Changes in Results at RDU level.

Statutory and Regulatory Authority

AS 44.23.020

Contact Information
Contact: John Skidmore, Deputy Attorney General Phone: (907) 269-5100 E-mail: john.skidmore@alaska.gov

First Judicial District Personal Services Information				
Authorized Positions			Personal Services Costs	
	<u>FY2022</u> <u>Management</u> <u>Plan</u>	<u>FY2023</u> <u>Governor</u>		
Full-time	19	19	Annual Salaries	1,548,938
Part-time	0	0	COLA	1,699
Nonpermanent	0	0	Premium Pay	0
			Annual Benefits	949,820
			<i>Less 3.55% Vacancy Factor</i>	<i>(88,857)</i>
			Lump Sum Premium Pay	0
Totals	19	19	Total Personal Services	2,411,600

Position Classification Summary					
Job Class Title	Anchorage	Fairbanks	Juneau	Others	Total
Attorney 3	0	0	0	1	1
Attorney 4	0	0	3	2	5
Attorney 5	0	0	2	1	3
Law Office Assistant 1	0	0	1	2	3
Law Office Assistant 2	0	0	1	1	2
Office Assistant 2	0	0	1	0	1
Victim/Witness Paralegal 2	0	0	2	2	4
Totals	0	0	10	9	19

Component Detail All Funds
Department of Law

Component: First Judicial District (2198)
RDU: Criminal Division (33)

Non-Formula Component

	FY2021 Actuals	FY2022 Conference Committee	FY2022 Authorized	FY2022 Management Plan	FY2023 Governor	FY2022 Management Plan vs FY2023 Governor	
71000 Personal Services	2,084.2	2,379.2	2,379.2	2,389.2	2,411.6	22.4	0.9%
72000 Travel	24.3	86.7	86.7	86.7	86.7	0.0	0.0%
73000 Services	158.5	310.8	310.8	300.8	300.8	0.0	0.0%
74000 Commodities	20.6	37.1	37.1	37.1	37.1	0.0	0.0%
75000 Capital Outlay	0.0	0.0	0.0	0.0	0.0	0.0	0.0%
77000 Grants, Benefits	0.0	0.0	0.0	0.0	0.0	0.0	0.0%
78000 Miscellaneous	0.0	0.0	0.0	0.0	0.0	0.0	0.0%
Totals	2,287.6	2,813.8	2,813.8	2,813.8	2,836.2	22.4	0.8%
Fund Sources:							
1004 Gen Fund (UGF)	2,254.8	2,755.1	2,755.1	2,755.1	2,794.2	39.1	1.4%
1005 GF/Prgm (DGF)	0.4	1.0	1.0	1.0	1.0	0.0	0.0%
1007 I/A Rcpts (Other)	32.4	41.6	41.6	41.6	41.0	-0.6	-1.4%
1108 Stat Desig (Other)	0.0	16.1	16.1	16.1	0.0	-16.1	-100.0%
Unrestricted General (UGF)	2,254.8	2,755.1	2,755.1	2,755.1	2,794.2	39.1	1.4%
Designated General (DGF)	0.4	1.0	1.0	1.0	1.0	0.0	0.0%
Other Funds	32.4	57.7	57.7	57.7	41.0	-16.7	-28.9%
Federal Funds	0.0	0.0	0.0	0.0	0.0	0.0	0.0%
Positions:							
Permanent Full Time	17	19	19	19	19	0	0.0%
Permanent Part Time	0	0	0	0	0	0	0.0%
Non Permanent	0	0	0	0	0	0	0.0%

Change Record Detail - Multiple Scenarios with Descriptions
Department of Law

Component: First Judicial District (2198)
RDU: Criminal Division (33)

Scenario/Change Record Title	Trans Type	Totals	Personal Services	Travel	Services	Commodities	Capital Outlay	Grants, Benefits	Miscellaneous	Positions		NP
										PFT	PPT	
***** Changes From FY2022 Conference Committee To FY2022 Authorized *****												
FY2022 Conference Committee												
	ConfCom	2,813.8	2,379.2	86.7	310.8	37.1	0.0	0.0	0.0	19	0	0
1004 Gen Fund		2,755.1										
1005 GF/Prgm		1.0										
1007 I/A Rcpts		41.6										
1108 Stat Desig		16.1										
Subtotal		2,813.8	2,379.2	86.7	310.8	37.1	0.0	0.0	0.0	19	0	0
***** Changes From FY2022 Authorized To FY2022 Management Plan *****												
Transfer Authority from Services for Anticipated Personal Service Expenditures												
	LIT	0.0	10.0	0.0	-10.0	0.0	0.0	0.0	0.0	0	0	0
Transfer authority from the services line to the personal services line for anticipated personal services costs. The remaining services authority is anticipated to be sufficient to cover operating expenditures.												
Subtotal		2,813.8	2,389.2	86.7	300.8	37.1	0.0	0.0	0.0	19	0	0
***** Changes From FY2022 Management Plan To FY2023 Governor *****												
FY2023 Salary and Benefit Adjustments												
	SalAdj	1.7	1.7	0.0	0.0	0.0	0.0	0.0	0.0	0	0	0
1004 Gen Fund		1.6										
1007 I/A Rcpts		0.1										
FY2023 SU BU - Supervisory Employees (SS) 1% COLA: \$1.7												
FY2023 Executive Health Insurance, SBS, and Risk Management Rate Changes												
	SalAdj	16.3	16.3	0.0	0.0	0.0	0.0	0.0	0.0	0	0	0
1004 Gen Fund		16.0										
1007 I/A Rcpts		0.3										
FY2023 Change Partially Exempt & Exempt Executive (EE) - Health Insurance from \$1,555 to \$1,685; SBS and Risk Management Rates: \$16.3												
FY2023 Supervisory Employees Health Insurance, SBS, and Risk Management Rate Changes												
	SalAdj	3.3	3.3	0.0	0.0	0.0	0.0	0.0	0.0	0	0	0
1004 Gen Fund		3.2										
1007 I/A Rcpts		0.1										
FY2023 Change Supervisory Employees (SS) - Health Insurance from \$1,555 to \$1,685; SBS and Risk Management Rates: \$3.3												

Change Record Detail - Multiple Scenarios with Descriptions
Department of Law

Component: First Judicial District (2198)
RDU: Criminal Division (33)

Scenario/Change Record Title	Trans Type	Totals	Personal Services	Travel	Services	Commodities	Capital Outlay	Grants, Benefits	Miscellaneous	Positions		NP	
										PFT	PPT		
FY2023 General Government Unit SBS and Risk Management Rate Changes													
1004 Gen Fund	SalAdj	1.1	1.1	1.1	0.0	0.0	0.0	0.0	0.0	0.0	0	0	0
FY2023 Change General Government Unit (GG, GP, GY, GZ) - SBS, and Risk Management Rates: \$1.1													
FY2023 PERS Actuarial Rate Adjustment to 24.79% Ch9 SLA2021 (SB55)													
1004 Gen Fund	SalAdj	-77.6	-78.7	-78.7	0.0	0.0	0.0	0.0	0.0	0.0	0	0	0
1007 I/A Rcpts		-1.1											
Includes: FY2023 Adjustment for PERS ARM Board Approved Rate of 24.79% (from 30.11%): \$-78.7													
Fully Fund Positions Added in FY2022 to Combat Sexual Assault													
1004 Gen Fund	Inc	78.7	78.7	78.7	0.0	0.0	0.0	0.0	0.0	0.0	0	0	0
The Department of Law, Criminal Division added a number of full-time prosecutors and support staff positions in the FY2022 Governor's budget in order to increase the resources available to combat sexual assault and the sexual abuse of minors across Alaska. While accepted, these positions were three-quarter funded by the Legislature in the FY2022 enacted budget. This increment will fully-fund the positions and allow the Department to maintain full-time employment of these positions.													
Realign PERS Rate Adjustment by Fund Source Ch9 SLA2021 (SB55)													
1004 Gen Fund	FndChg	16.1	0.0	0.0	0.0	0.0	0.0	0.0	0.0	0.0	0	0	0
1108 Stat Desig		-16.1											
Replace unrealizable SDPR authority assigned in SB55 fiscal note (Ch 9 SLA 2021).													
Totals		2,836.2	2,411.6	86.7	300.8	37.1	0.0	0.0	0.0	0.0	19	0	0

Line Item Detail (1676)
Department of Law
Travel

Component: First Judicial District (2198)

Line Number	Line Name		FY2021 Actuals	FY2022 Management Plan	FY2023 Governor
2000	Travel		24.3	86.7	86.7
Object Class	Servicing Agency	Explanation	FY2021 Actuals	FY2022 Management Plan	FY2023 Governor
2000 Travel Detail Totals			24.3	86.7	86.7
2000	In-State Employee Travel	Travel for attorneys to interview witnesses and attend court proceedings, as well as for necessary training for both attorneys and paraprofessionals. Includes travel for management purposes.	4.2	46.7	46.7
2001	In-State Non-Employee Travel	Travel costs for witnesses to testify in court.	8.1	25.0	25.0
2005	Moving Costs	Moving costs.	12.0	15.0	15.0

Line Item Detail (1676)
Department of Law
Services

Component: First Judicial District (2198)

Line Number	Line Name		FY2021 Actuals	FY2022 Management Plan	FY2023 Governor
3000	Services		158.5	300.8	300.8
Object Class	Servicing Agency	Explanation	FY2021 Actuals	FY2022 Management Plan	FY2023 Governor
3000 Services Detail Totals			158.5	300.8	300.8
3000	Education Services	Conferences, training and memberships.	7.9	10.0	10.0
3002	Legal and Judicial Services	Depositions, research costs, expert witness and consultant fees.	7.3	10.0	10.0
3003	Information Technology	Training, consulting and software licensing and maintenance. Annual maintenance fee for mission-critical information management systems.	4.3	5.7	5.7
3004	Telecommunications	Local telephone service, long distance charges and cellular phone services paid to third-party telephone utilities.	20.0	20.0	20.0
3006	Delivery Services	Freight, courier, postage, and transportation of trial exhibit materials.	0.3	2.0	2.0
3007	Advertising and Promotions	Publication of legal notices.	0.0	0.2	0.2
3008	Utilities	Waste management disposal costs not included in lease.	0.1	0.1	0.1
3009	Structure/Infrastructure/Land	Rentals/leases - records and evidence storage.	10.7	11.0	11.0
3010	Equipment/Machinery	Office equipment rental - copier and postage meters.	2.3	2.3	2.3
3011	Other Services	Cost transfers and miscellaneous items within the services line (commissions, etc.).	0.9	1.0	1.0
3013	Inter-Agency Data Processing	Law - Administrative Services (2164) RSA Law, Information services, data	6.4	10.0	10.0
Page 30			FY2023 Governor Department of Law	Released December 15, 2021	

Line Item Detail (1676)
Department of Law
Services

Component: First Judicial District (2198)

Object Class	Servicing Agency	Explanation	FY2021 Actuals	FY2022 Management Plan	FY2023 Governor
3000 Services Detail Totals			158.5	300.8	300.8
	Operations Allocation	processing investments and support.			
3017	Inter-Agency Information Technology Non-Telecommunications	Admin - Department-wide RSA Administration, Office of Information Technology computer services.	67.9	100.5	100.5
3018	Inter-Agency Information Technology Telecommunications	Admin - Department-wide RSA Administration, Office of Information Technology telecommunications services.	8.9	30.0	30.0
3021	Inter-Agency Mail	Admin - Department-wide RSA Administration, Central Mail.	2.2	3.0	3.0
3022	Inter-Agency Human Resources	Law - Administrative Services (2164) RSA Law, Human Resources position.	15.4	20.0	20.0
3026	Inter-Agency Insurance	Admin - Department-wide RSA Administration, Risk Management.	1.1	2.0	2.0
3027	Inter-Agency Financial	Admin - Department-wide RSA Administration, Finance Chargeback (IRIS).	2.7	7.0	7.0
3028	Inter-Agency Americans with Disabilities Act Compliance	Admin - Department-wide RSA Administration - Division of Personnel and Labor Relations, Americans with Disabilities Act.	0.1	1.0	1.0
3038	Inter-Agency Management/Consulting	Law - Administrative Services (2164) RSA Law, Information services, project and management support.	0.0	65.0	65.0

Line Item Detail (1676)
Department of Law
Commodities

Component: First Judicial District (2198)

Line Number	Line Name		FY2021 Actuals	FY2022 Management Plan	FY2023 Governor
4000	Commodities		20.6	37.1	37.1
Object Class	Servicing Agency	Explanation	FY2021 Actuals	FY2022 Management Plan	FY2023 Governor
4000 Commodities Detail Totals			20.6	37.1	37.1
4000	Business	Reference materials and subscriptions, including statutes, software applications, non-capital desktop refresh, and miscellaneous office supplies.	19.9	34.0	34.0
4002	Household/Institutional	Institutional supplies for cleaning and maintenance.	0.0	1.1	1.1
4004	Safety	Safety and security purchases.	0.7	2.0	2.0

Revenue Detail (1681)
Department of Law

Component: First Judicial District (2198)

Revenue Type (OMB Fund Code) Revenue Source	Component	Comment	FY2021 Actuals	FY2022 Management Plan	FY2023 Governor
5005 GF/Prgm (1005 GF/Prgm)			0.4	1.0	1.0
5119 Program Receipts Law - Charges for Services		Discovery receipts - receipts from private attorneys.	0.4	1.0	1.0
5007 I/A Rcpts (1007 I/A Rcpts)			32.4	41.6	41.0
5301 Inter-Agency Receipts	Courts - Department-wide	Therapeutic Courts (Wellness Court): Participating attorneys recommend potential participants and review them for eligibility, making case-related decisions - Southeast AK RSA. Program code: CM03651151.	32.4	41.6	41.0
5108 Stat Desig (1108 Stat Desig)			0.0	16.1	0.0
5206 Statutory Designated Program Receipts - Contracts		Uncollectible state designated program receipt authority.	0.0	16.1	0.0
6004 Gen Fund (1004 Gen Fund)			0.2	0.0	0.0
6046 General Fund - Prior Year Reimbursement Recovery		Prior year recovery	0.2	0.0	0.0

Inter-Agency Services (1682)
Department of Law

Component: First Judicial District (2198)

				FY2021 Actuals	FY2022 Management Plan	FY2023 Governor
Component Totals				104.7	238.5	238.5
With Department of Law				21.8	95.0	95.0
With Department of Administration				82.9	143.5	143.5
Object Class	Servicing Agency	Explanation	FY2021 Actuals	FY2022 Management Plan	FY2023 Governor	
3013	Inter-Agency Data Processing Operations Allocation	Law - Administrative Services (2164)	RSA Law, Information services, data processing investments and support.	6.4	10.0	10.0
3017	Inter-Agency Information Technology Non-Telecommunications	Admin - Department-wide	RSA Administration, Office of Information Technology computer services.	67.9	100.5	100.5
3018	Inter-Agency Information Technology Telecommunications	Admin - Department-wide	RSA Administration, Office of Information Technology telecommunications services.	8.9	30.0	30.0
3021	Inter-Agency Mail	Admin - Department-wide	RSA Administration, Central Mail.	2.2	3.0	3.0
3022	Inter-Agency Human Resources	Law - Administrative Services (2164)	RSA Law, Human Resources position.	15.4	20.0	20.0
3026	Inter-Agency Insurance	Admin - Department-wide	RSA Administration, Risk Management.	1.1	2.0	2.0
3027	Inter-Agency Financial	Admin - Department-wide	RSA Administration, Finance Chargeback (IRIS).	2.7	7.0	7.0
3028	Inter-Agency Americans with Disabilities Act Compliance	Admin - Department-wide	RSA Administration - Division of Personnel and Labor Relations, Americans with Disabilities Act.	0.1	1.0	1.0
3038	Inter-Agency Management/Consulting	Law - Administrative Services (2164)	RSA Law, Information services, project and management support.	0.0	65.0	65.0

Personal Services Expenditure Detail
Department of Law

Scenario: FY2023 Governor (18673)
Component: First Judicial District (2198)
RDU: Criminal Division (33)

PCN	Job Class Title	Time Status	Retire Code	Barg Unit	Location	Salary Sched	Range / Step	Comp Months	Split / Count	Annual Salaries	COLA	Premium Pay	Annual Benefits	Total Costs	UGF Amount
03-0081	Attorney 4	FT	A	XE	Juneau	N05	24C / D	12.0		101,485	0	0	58,020	159,505	159,505
03-1002	Attorney 5	FT	A	XE	Juneau	N05	25J / K	12.0		128,076	0	0	67,920	195,996	195,996
03-1014	Law Office Assistant 2	FT	A	SS	Juneau	605	13C / D	12.0		52,952	727	0	40,095	93,774	87,210
03-1023	Law Office Assistant 2	FT	A	SS	Ketchikan	99	13Q	12.0		70,826	972	0	46,750	118,548	118,548
03-1025	Attorney 5	FT	A	XE	Ketchikan	N00	25F / J	12.0		117,668	0	0	64,045	181,713	181,713
03-1027	Law Office Assistant 1	FT	A	GP	Juneau	205	11B / C	12.0		41,705	0	0	34,308	76,013	76,013
03-1034	Attorney 4	FT	A	XE	Ketchikan	N00	24F / J	12.0		107,716	0	0	60,340	168,056	168,056
03-1036	Law Office Assistant 1	FT	A	GP	Ketchikan	200	11B / C	12.0		39,252	0	0	33,395	72,647	72,647
03-1134	Victim/Witness Paralegal 2	FT	A	GP	Juneau	205	16K / L	12.0		75,112	0	0	46,746	121,858	121,858
03-1136	Victim/Witness Paralegal 2	FT	A	GP	Ketchikan	200	16D / E	12.0		58,376	0	0	40,515	98,891	98,891
03-1156	Attorney 4	FT	A	XE	Sitka	N05	24J	12.0		115,401	0	0	63,201	178,602	178,602
03-1171	Victim/Witness Paralegal 2	FT	A	GP	Sitka	205	16B / C	12.0		58,105	0	0	40,414	98,519	98,519
03-1230	Attorney 4	FT	A	XE	Juneau	N05	24M	12.0		127,023	0	0	67,528	194,551	161,477
03-1251	Attorney 3	FT	A	XE	Ketchikan	N00	22F	12.0		92,957	0	0	54,845	147,802	147,802
03-1315	Law Office Assistant 1	FT	A	GP	Sitka	205	11D / E	12.0		43,529	0	0	34,987	78,516	78,516
03-1336	Attorney 4	FT	A	XE	Juneau	N05	24E / F	12.0		109,343	0	0	60,946	170,289	170,289
03-1341	Office Assistant 2	FT	A	GP	Juneau	205	10B / C	12.0		39,335	0	0	33,426	72,761	72,761
03-1355	Victim/Witness Paralegal 2	FT	A	GP	Juneau	205	16A / B	12.0		56,106	0	0	39,670	95,776	95,776
03-1361	Attorney 5	FT	A	XE	Juneau	N05	25D / E	12.0		113,971	0	0	62,669	176,640	176,640

Total Positions				Total Salary Costs:	1,548,938
Full Time Positions:				Total COLA:	1,699
Part Time Positions:				Total Premium Pay:	0
Non Permanent Positions:				Total Benefits:	949,820
Positions in Component:				Total Pre-Vacancy:	2,500,457
				Minus Vacancy Adjustment of 3.55%:	(88,857)
				Total Post-Vacancy:	2,411,600
Total Component Months: 228.0				Plus Lump Sum Premium Pay:	0
				Personal Services Line 100:	2,411,600

PCN Funding Sources:	Pre-Vacancy	Post-Vacancy	Percent
1004 General Fund Receipts	2,460,819	2,373,371	98.41%
1007 Interagency Receipts	39,638	38,229	1.59%
Total PCN Funding:	2,500,457	2,411,600	100.00%

Note: If a position is split, an asterisk (*) will appear in the Split/Count column. If the split position is also counted in the component, two asterisks (**) will appear in this column. [No valid job title] appearing in the Job Class Title indicates that the PCN has an invalid class code or invalid range for the class code effective date of this scenario.

CRIMINAL DIVISION

First Judicial District

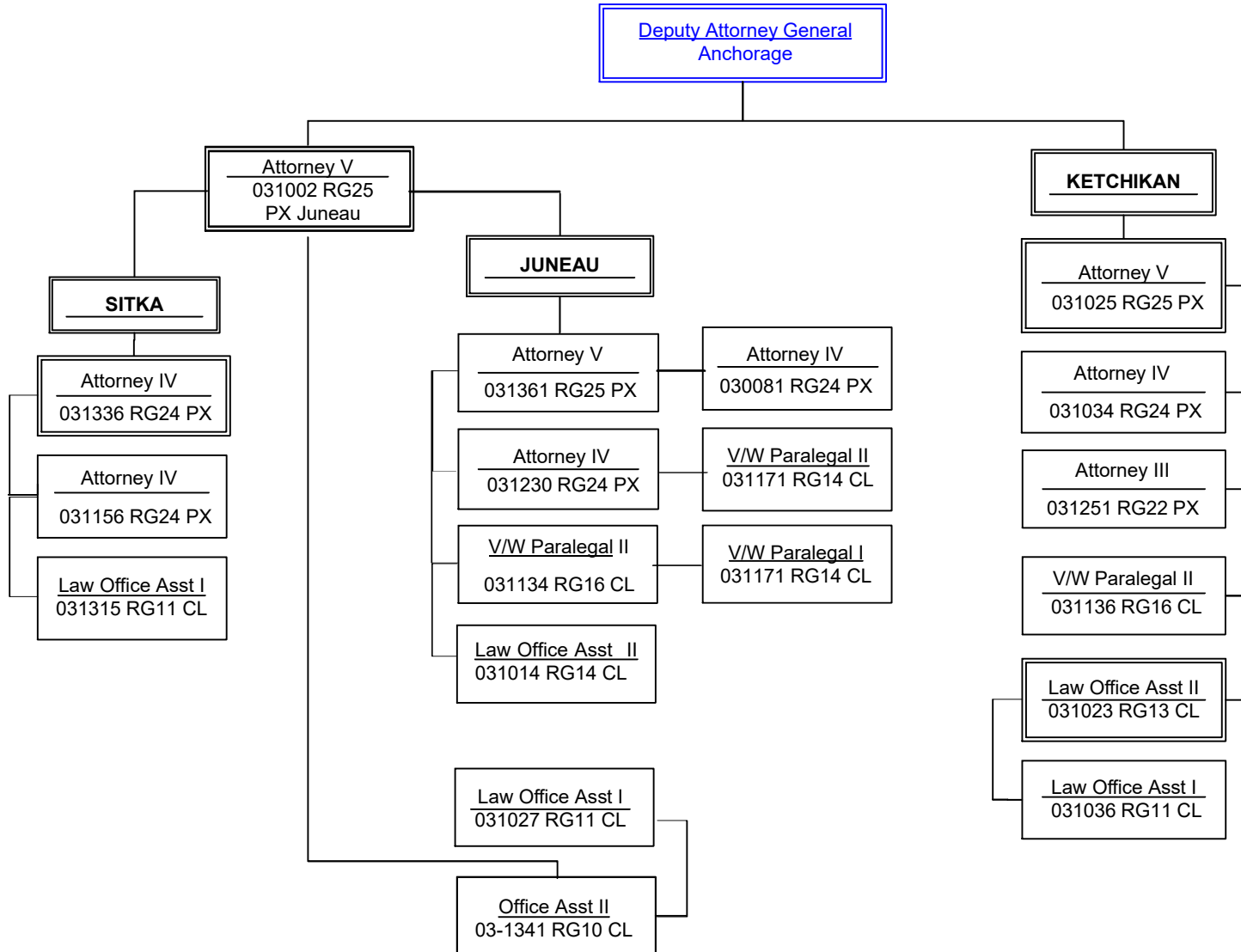

State of Alaska FY2023 Governor's Operating Budget

Department of Law Second Judicial District Component Budget Summary

Component: Second Judicial District

Contribution to Department's Mission

This component contributes to the department's mission by prosecuting and convicting criminal offenders within the Second Judicial District (North and Northwest Alaska).

Core Services

- Prosecutes violations of state criminal law by both adults and juveniles in the Second Judicial District.
- Provides day-to-day advice to state and local law enforcement agencies conducting criminal investigations and serves as legal advisor to grand juries.
- Handles probation revocation actions, all sentence and sufficiency of evidence appeals and most post-conviction relief proceedings.
- Provides victim-witness assistance services such as: information on court procedures required by statute and the Alaska Constitution; applying for restitution; arrangement of travel and payment for expenses and court-mandated witness fees; assistance with domestic violence orders and violent crimes compensation procedures; and preparation of victims and witnesses to testify in court.

Major Component Accomplishments in 2021

See Accomplishments at RDU level.

Key Component Challenges

See Key Challenges at RDU level.

Significant Changes in Results to be Delivered in FY2023

See Changes in Results at RDU level.

Statutory and Regulatory Authority

AS 44.23.020

Contact Information

Contact: John Skidmore, Deputy Attorney General
Phone: (907) 269-5100
E-mail: john.skidmore@alaska.gov

Second Judicial District Personal Services Information				
Authorized Positions			Personal Services Costs	
	<u>FY2022</u> <u>Management</u> <u>Plan</u>	<u>FY2023</u> <u>Governor</u>		
Full-time	15	15	Annual Salaries	1,638,172
Part-time	0	0	COLA	948
Nonpermanent	0	0	Premium Pay	0
			Annual Benefits	896,397
			<i>Less 3.31% Vacancy Factor</i>	(84,017)
			Lump Sum Premium Pay	0
Totals	15	15	Total Personal Services	2,451,500

Position Classification Summary					
Job Class Title	Anchorage	Fairbanks	Juneau	Others	Total
Attorney 2	0	0	0	1	1
Attorney 3	0	0	0	2	2
Attorney 4	0	0	0	1	1
Attorney 5	0	0	0	3	3
Law Office Assistant 1	0	0	0	3	3
Law Office Assistant 2	0	0	0	1	1
Victim/Witness Paralegal 1	0	0	0	1	1
Victim/Witness Paralegal 2	0	0	0	3	3
Totals	0	0	0	15	15

Component Detail All Funds
Department of Law

Component: Second Judicial District (2199)
RDU: Criminal Division (33)

Non-Formula Component

	FY2021 Actuals	FY2022 Conference Committee	FY2022 Authorized	FY2022 Management Plan	FY2023 Governor	FY2022 Management Plan vs FY2023 Governor	
71000 Personal Services	1,512.2	2,319.0	2,319.0	2,394.0	2,451.5	57.5	2.4%
72000 Travel	28.3	134.7	134.7	134.7	134.7	0.0	0.0%
73000 Services	251.2	420.6	420.6	420.6	420.6	0.0	0.0%
74000 Commodities	6.6	44.4	44.4	44.4	44.4	0.0	0.0%
75000 Capital Outlay	0.0	0.0	0.0	0.0	0.0	0.0	0.0%
77000 Grants, Benefits	0.0	0.0	0.0	0.0	0.0	0.0	0.0%
78000 Miscellaneous	0.0	0.0	0.0	0.0	0.0	0.0	0.0%
Totals	1,798.3	2,918.7	2,918.7	2,993.7	3,051.2	57.5	1.9%
Fund Sources:							
1004 Gen Fund (UGF)	1,631.8	2,594.7	2,594.7	2,669.7	2,733.5	63.8	2.4%
1005 GF/Prgm (DGF)	0.0	1.0	1.0	1.0	1.0	0.0	0.0%
1108 Stat Desig (Other)	166.5	323.0	323.0	323.0	316.7	-6.3	-2.0%
Unrestricted General (UGF)	1,631.8	2,594.7	2,594.7	2,669.7	2,733.5	63.8	2.4%
Designated General (DGF)	0.0	1.0	1.0	1.0	1.0	0.0	0.0%
Other Funds	166.5	323.0	323.0	323.0	316.7	-6.3	-2.0%
Federal Funds	0.0	0.0	0.0	0.0	0.0	0.0	0.0%
Positions:							
Permanent Full Time	12	15	15	15	15	0	0.0%
Permanent Part Time	0	0	0	0	0	0	0.0%
Non Permanent	0	0	0	0	0	0	0.0%

Change Record Detail - Multiple Scenarios with Descriptions
Department of Law

Component: Second Judicial District (2199)
RDU: Criminal Division (33)

Scenario/Change Record Title	Trans Type	Totals	Personal Services	Travel	Services	Commodities	Capital Outlay	Grants, Benefits	Miscellaneous	Positions		NP
										PFT	PPT	
***** Changes From FY2022 Conference Committee To FY2022 Authorized *****												
FY2022 Conference Committee												
	ConfCom	2,918.7	2,319.0	134.7	420.6	44.4	0.0	0.0	0.0	15	0	0
1004 Gen Fund		2,594.7										
1005 GF/Prgm		1.0										
1108 Stat Desig		323.0										
Subtotal		2,918.7	2,319.0	134.7	420.6	44.4	0.0	0.0	0.0	15	0	0
***** Changes From FY2022 Authorized To FY2022 Management Plan *****												
Transfer Attorney 5 (03-0110) from Criminal Appeals/Special Litigation for Required Legal Expertise												
	Trin	75.0	75.0	0.0	0.0	0.0	0.0	0.0	0.0	1	0	0
1004 Gen Fund		75.0										
Transfer one full-time Attorney 5 position (03-0110), range 25, located in Anchorage, from Criminal Appeals/Special Litigation to Second Judicial District, Kotzebue office to keep pace with the required level of legal expertise needed within the office. The remaining staff in Criminal Appeals/Special Litigation are sufficient to accommodate anticipated workload.												
Transfer Attorney 4 (03-1319) to Criminal Appeals/Special Litigation for Required Legal Expertise												
	Trout	0.0	0.0	0.0	0.0	0.0	0.0	0.0	0.0	-1	0	0
Transfer one full-time Attorney 4 position (03-1319), range 24, located in Kotzebue, from the Second Judicial District to Criminal Appeals/Special Litigation, Anchorage office to keep pace with the required level of legal expertise needed within the office. The remaining staff in the Second Judicial District are sufficient to accommodate anticipated workload.												
Subtotal		2,993.7	2,394.0	134.7	420.6	44.4	0.0	0.0	0.0	15	0	0
***** Changes From FY2022 Management Plan To FY2023 Governor *****												
FY2023 Salary and Benefit Adjustments												
	SalAdj	0.9	0.9	0.0	0.0	0.0	0.0	0.0	0.0	0	0	0
1004 Gen Fund		0.9										
FY2023 SU BU - Supervisory Employees (SS) 1% COLA: \$0.9												
FY2023 Executive Health Insurance, SBS, and Risk Management Rate Changes												
	SalAdj	14.3	14.3	0.0	0.0	0.0	0.0	0.0	0.0	0	0	0
1004 Gen Fund		14.3										
FY2023 Change Partially Exempt & Exempt Executive (EE) - Health Insurance from \$1,555 to \$1,685; SBS and Risk Management Rates: \$14.3												
FY2023 Supervisory Employees Health Insurance, SBS, and Risk Management Rate Changes												

Change Record Detail - Multiple Scenarios with Descriptions
Department of Law

Component: Second Judicial District (2199)
RDU: Criminal Division (33)

Scenario/Change Record Title	Trans Type	Totals	Personal Services	Travel	Services	Commodities	Capital Outlay	Grants, Benefits	Miscellaneous	Positions		
										PFT	PPT	NP
1004 Gen Fund	SalAdj	1.7	1.7	0.0	0.0	0.0	0.0	0.0	0.0	0	0	0
FY2023 Change Supervisory Employees (SS) - Health Insurance from \$1,555 to \$1,685; SBS and Risk Management Rates: \$1.7												
FY2023 General Government Unit SBS and Risk Management Rate Changes												
1004 Gen Fund	SalAdj	0.9	1.3	0.0	0.0	0.0	0.0	0.0	0.0	0	0	0
1108 Stat Desig		0.4										
FY2023 Change General Government Unit (GG, GP, GY, GZ) - SBS, and Risk Management Rates: \$1.3												
FY2023 PERS Actuarial Rate Adjustment to 24.79% Ch9 SLA2021 (SB55)												
1004 Gen Fund	SalAdj	-75.2	-81.9	0.0	0.0	0.0	0.0	0.0	0.0	0	0	0
1108 Stat Desig		-6.7										
Includes: FY2023 Adjustment for PERS ARM Board Approved Rate of 24.79% (from 30.11%): \$-81.9												
Fully Fund Positions Added in FY2022 to Combat Sexual Assault												
1004 Gen Fund	Inc	121.2	121.2	0.0	0.0	0.0	0.0	0.0	0.0	0	0	0
The Department of Law, Criminal Division added a number of full-time prosecutors and support staff positions in the FY2022 Governor's budget in order to increase the resources available to combat sexual assault and the sexual abuse of minors across Alaska. While accepted, these positions were three-quarter funded by the Legislature in the FY2022 enacted budget. This increment will fully-fund the positions and allow the department to maintain full-time employment of these positions.												
Totals		3,051.2	2,451.5	134.7	420.6	44.4	0.0	0.0	0.0	15	0	0

Line Item Detail (1676)
Department of Law
Travel

Component: Second Judicial District (2199)

Line Number	Line Name		FY2021 Actuals	FY2022 Management Plan	FY2023 Governor
2000	Travel		28.3	134.7	134.7
Object Class	Servicing Agency	Explanation	FY2021 Actuals	FY2022 Management Plan	FY2023 Governor
2000 Travel Detail Totals			28.3	134.7	134.7
2000	In-State Employee Travel	Travel for attorneys to interview witnesses and attend court proceedings, as well as for necessary training for both attorneys and paraprofessionals. Includes travel for management purposes.	17.2	63.3	63.3
2001	In-State Non-Employee Travel	Travel costs for witnesses to testify in court.	3.6	59.4	59.4
2005	Moving Costs	Moving costs.	7.5	12.0	12.0

Line Item Detail (1676)
Department of Law
Services

Component: Second Judicial District (2199)

Line Number	Line Name		FY2021 Actuals	FY2022 Management Plan	FY2023 Governor
3000	Services		251.2	420.6	420.6
Object Class	Servicing Agency	Explanation	FY2021 Actuals	FY2022 Management Plan	FY2023 Governor
3000 Services Detail Totals			251.2	420.6	420.6
3000	Education Services	Conferences, training and memberships.	3.7	10.0	10.0
3001	Financial Services	Bankcard service fees.	0.1	1.0	1.0
3002	Legal and Judicial Services	Depositions, research costs, expert witness and consultant fees.	1.0	1.0	1.0
3003	Information Technology	Training, consulting and software licensing and maintenance. Annual maintenance fee for mission-critical information management systems.	2.1	10.0	10.0
3004	Telecommunications	Local telephone service, long distance charges and cellular phone services paid to third-party telephone utilities.	24.2	25.0	25.0
3006	Delivery Services	Freight, courier, postage, and transportation of trial exhibit materials.	0.6	10.0	10.0
3009	Structure/Infrastructure/Land	Rentals/leases - records and evidence storage.	0.0	10.0	10.0
3010	Equipment/Machinery	Office equipment rental - copier and postage meters.	0.0	2.0	2.0
3011	Other Services	Cost transfers and miscellaneous items within the services line (commissions, etc.).	0.2	5.0	5.0
3013	Inter-Agency Data Processing Operations Allocation	Law - Administrative Services (2164) RSA Law, Information services, data processing investments and support.	4.5	15.0	15.0
3017	Inter-Agency Information Technology	Admin - Department-wide RSA Administration, Office of	47.9	70.0	70.0

Line Item Detail (1676)
Department of Law
Services

Component: Second Judicial District (2199)

Object Class	Servicing Agency	Explanation	FY2021 Actuals	FY2022 Management Plan	FY2023 Governor
3000 Services Detail Totals			251.2	420.6	420.6
Non-Telecommunications		Information Technology computer services.			
3018 Inter-Agency Information Technology Telecommunications	Admin - Department-wide	RSA Administration, Office of Information Technology telecommunications services.	6.2	15.0	15.0
3022 Inter-Agency Human Resources	Law - Administrative Services (2164)	RSA Law, Human Resources position.	10.9	12.0	12.0
3023 Inter-Agency Building Leases	Admin - Department-wide	Leased office space managed by General Services.	140.6	145.0	145.0
3026 Inter-Agency Insurance	Admin - Department-wide	RSA Administration, Risk Management.	0.8	5.0	5.0
3027 Inter-Agency Financial	Admin - Department-wide	RSA Administration, Finance Chargeback (IRIS).	1.9	5.2	5.2
3028 Inter-Agency Americans with Disabilities Act Compliance	Admin - Department-wide	RSA Administration - Division of Personnel and Labor Relations, Americans with Disabilities Act.	0.1	1.0	1.0
3037 State Equipment Fleet	Trans - Department-wide	State vehicle maintenance and operations.	6.4	20.0	20.0
3038 Inter-Agency Management/Consulting	Law - Administrative Services (2164)	RSA Law, Information services, project and management support.	0.0	58.4	58.4

Line Item Detail (1676)
Department of Law
Commodities

Component: Second Judicial District (2199)

Line Number	Line Name		FY2021 Actuals	FY2022 Management Plan	FY2023 Governor
4000	Commodities		6.6	44.4	44.4
Object Class	Servicing Agency	Explanation	FY2021 Actuals	FY2022 Management Plan	FY2023 Governor
4000 Commodities Detail Totals			6.6	44.4	44.4
4000	Business	Reference materials and subscriptions, including statutes, software applications, non-capital desktop refresh, and miscellaneous office supplies.	6.5	37.0	37.0
4020	Equipment Fuel	Equipment fuel	0.1	7.4	7.4

Revenue Detail (1681)
Department of Law

Component: Second Judicial District (2199)

Revenue Type (OMB Fund Code) Revenue Source	Component	Comment	FY2021 Actuals	FY2022 Management Plan	FY2023 Governor
5005 GF/Prgm (1005 GF/Prgm)			0.0	1.0	1.0
5119 Program Receipts Law - Charges for Services		Discovery receipts - receipts from private attorneys.	0.0	1.0	1.0
5108 Stat Desig (1108 Stat Desig)			166.5	323.0	316.7
5206 Statutory Designated Program Receipts - Contracts		Funding from the North Slope Borough to provide additional personnel and resources to serve the Second Judicial District.	166.5	300.0	300.0
5206 Statutory Designated Program Receipts - Contracts		Uncollectible state designated program receipt authority.	0.0	23.0	16.7

Inter-Agency Services (1682)
Department of Law

Component: Second Judicial District (2199)

				FY2021 Actuals	FY2022 Management Plan	FY2023 Governor
Component Totals				219.3	346.6	346.6
With Department of Law				15.4	85.4	85.4
With Department of Administration				197.5	241.2	241.2
With Department of Transportation/Public Facilities				6.4	20.0	20.0
Object Class	Servicing Agency	Explanation	FY2021 Actuals	FY2022 Management Plan	FY2023 Governor	
3013	Inter-Agency Data Processing Operations Allocation	Law - Administrative Services (2164)	RSA Law, Information services, data processing investments and support.	4.5	15.0	15.0
3017	Inter-Agency Information Technology Non-Telecommunications	Admin - Department-wide	RSA Administration, Office of Information Technology computer services.	47.9	70.0	70.0
3018	Inter-Agency Information Technology Telecommunications	Admin - Department-wide	RSA Administration, Office of Information Technology telecommunications services.	6.2	15.0	15.0
3022	Inter-Agency Human Resources	Law - Administrative Services (2164)	RSA Law, Human Resources position.	10.9	12.0	12.0
3023	Inter-Agency Building Leases	Admin - Department-wide	Leased office space managed by General Services.	140.6	145.0	145.0
3026	Inter-Agency Insurance	Admin - Department-wide	RSA Administration, Risk Management.	0.8	5.0	5.0
3027	Inter-Agency Financial	Admin - Department-wide	RSA Administration, Finance Chargeback (IRIS).	1.9	5.2	5.2
3028	Inter-Agency Americans with Disabilities Act Compliance	Admin - Department-wide	RSA Administration - Division of Personnel and Labor Relations, Americans with Disabilities Act.	0.1	1.0	1.0
3037	State Equipment Fleet	Trans - Department-wide	State vehicle maintenance and operations.	6.4	20.0	20.0
3038	Inter-Agency Management/Consulting	Law - Administrative Services (2164)	RSA Law, Information services, project and management support.	0.0	58.4	58.4

Personal Services Expenditure Detail
Department of Law

Scenario: FY2023 Governor (18673)
Component: Second Judicial District (2199)
RDU: Criminal Division (33)

PCN	Job Class Title	Time Status	Retire Code	Barg Unit	Location	Salary Sched	Range / Step	Comp Months	Split / Count	Annual Salaries	COLA	Premium Pay	Annual Benefits	Total Costs	UGF Amount
03-0110	Attorney 5	FT	A	XE	Kotzebue	N60	25L / M	12.0		207,519	0	0	93,768	301,287	301,287
03-1005	Attorney 5	FT	A	XE	Nome	99	25N / O	12.0		190,195	0	0	88,381	278,576	278,576
03-1019	Law Office Assistant 2	FT	A	SS	Nome	637	13C / D	12.0		69,108	948	0	46,110	116,166	116,166
03-1108	Victim/Witness Paralegal 2	FT	A	GP	Kotzebue	260	16B / C	12.0		88,700	0	0	51,804	140,504	140,504
03-1232	Attorney 3	FT	A	XE	Nome	N37	22E / F	12.0		123,498	0	0	66,216	189,714	189,714
03-1282	Victim/Witness Paralegal 1	FT	A	GP	Nome	237	14E / F	12.0		72,756	0	0	45,868	118,624	118,624
03-1308	Attorney 2	FT	A	XE	Kotzebue	N60	20C / D	12.0		117,962	0	0	64,155	182,117	182,117
03-1329	Law Office Assistant 1	FT	A	GP	Kotzebue	260	11C / D	12.0		65,800	0	0	43,279	109,079	109,079
03-1348	Attorney 4	FT	A	XE	Utqiagvik	N50	24E / F	12.0		154,677	0	0	77,335	232,012	232,012
03-1349	Attorney 3	FT	A	XE	Utqiagvik	N50	22C / D	12.0		129,976	0	0	68,627	198,603	198,603
03-1350	Victim/Witness Paralegal 2	FT	A	GP	Utqiagvik	250	16B / C	12.0		82,288	0	0	49,417	131,705	0
03-1351	Law Office Assistant 1	FT	A	GP	Utqiagvik	250	11B / C	12.0		59,995	0	0	41,117	101,112	0
03-1356	Victim/Witness Paralegal 2	FT	A	GP	Nome	237	16A / B	12.0		73,201	0	0	46,034	119,235	119,235
03-1362	Attorney 5	FT	A	XE	Nome	N37	25D / E	12.0		148,703	0	0	75,477	224,180	224,180
03-1371	Law Office Assistant 1	FT	A	GP	Nome	137	11B / C	12.0		53,794	0	0	38,809	92,603	92,603

	Total Positions	New	Deleted		Total Salary Costs:	1,638,172
					Total COLA:	948
	Full Time Positions:	15	0	0	Total Premium Pay:	0
	Part Time Positions:	0	0	0	Total Benefits:	896,397
	Non Permanent Positions:	0	0	0		
	Positions in Component:	15	0	0	Total Pre-Vacancy:	2,535,517
					Minus Vacancy Adjustment of 3.31%:	(84,017)
					Total Post-Vacancy:	2,451,500
	Total Component Months:	180.0			Plus Lump Sum Premium Pay:	0
					Personal Services Line 100:	2,451,500

PCN Funding Sources:	Pre-Vacancy	Post-Vacancy	Percent
1004 General Fund Receipts	2,302,700	2,226,398	90.82%
1108 Statutory Designated Program Receipts	232,817	225,102	9.18%
Total PCN Funding:	2,535,517	2,451,500	100.00%

Note: If a position is split, an asterisk (*) will appear in the Split/Count column. If the split position is also counted in the component, two asterisks (**) will appear in this column. [No valid job title] appearing in the Job Class Title indicates that the PCN has an invalid class code or invalid range for the class code effective date of this scenario.

CRIMINAL DIVISION

Second Judicial District

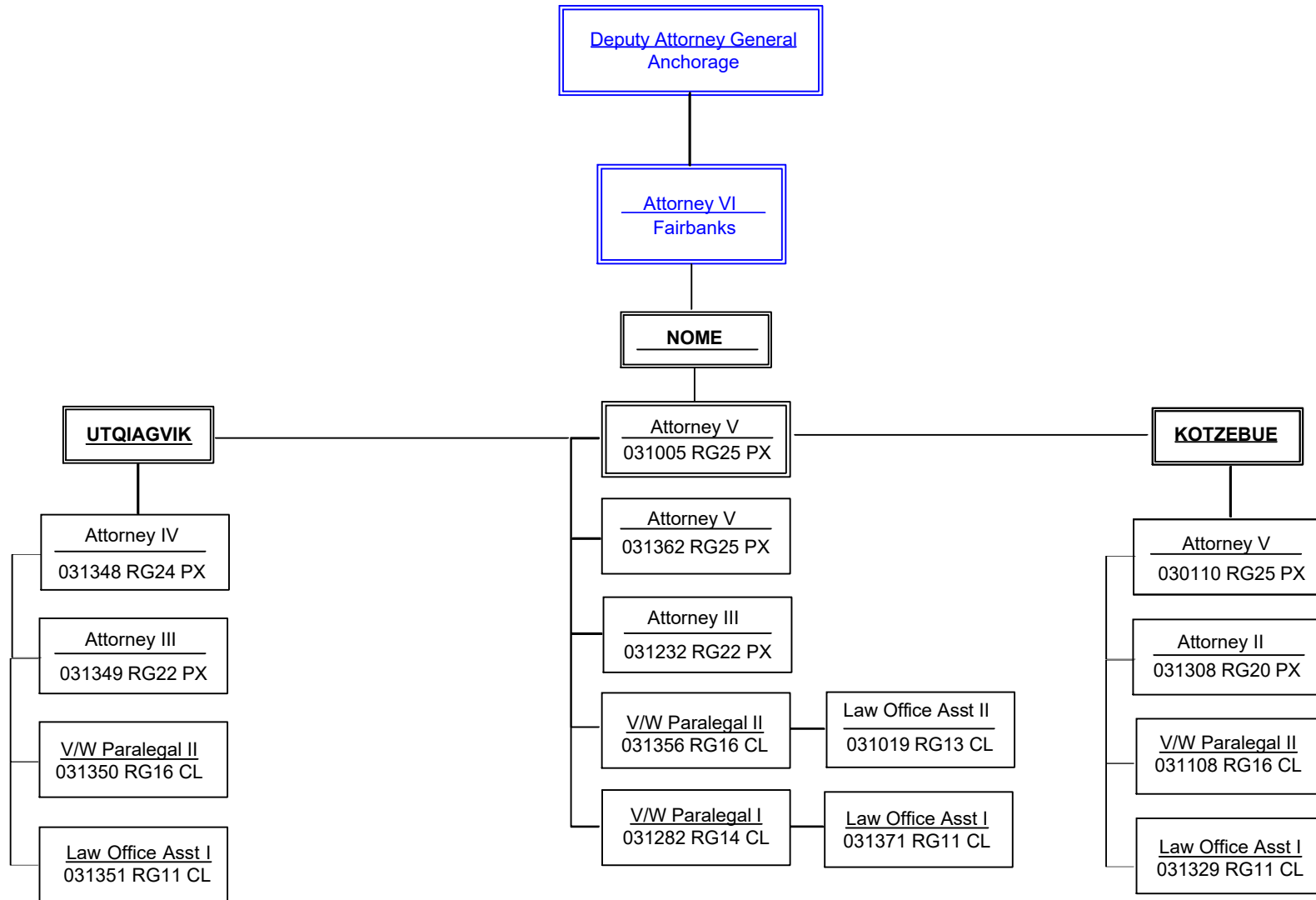

State of Alaska FY2023 Governor's Operating Budget

Department of Law Third Judicial District: Anchorage Component Budget Summary

Component: Third Judicial District: Anchorage

Contribution to Department's Mission

This component contributes to the department's mission by prosecuting and convicting criminal offenders within the Third Judicial District (Southcentral and the Aleutian Chain) in the Anchorage area.

Core Services

- Prosecutes violations of state criminal law by both adults and juveniles in the Third Judicial District.
- Provides day-to-day advice to state and local law enforcement agencies conducting criminal investigations and serves as legal advisor to grand juries.
- Handles probation revocation actions, all sentence and sufficiency of evidence appeals and most post-conviction relief proceedings.
- Participates in specialized court and probation programs.
- Provides victim-witness assistance services such as: information on court procedures required by statute and the Alaska Constitution; applying for restitution; arrangement of travel and payment for expenses and court-mandated witness fees; assistance with domestic violence orders and violent crimes compensation procedures; and preparation of victims and witnesses to testify in court.

Major Component Accomplishments in 2021

See Accomplishments at RDU level.

Key Component Challenges

See Key RDU challenges.

Significant Changes in Results to be Delivered in FY2023

See Results at RDU level.

Statutory and Regulatory Authority

AS 44.23.020

Contact Information

Contact: John Skidmore, Deputy Attorney General
Phone: (907) 269-5100
E-mail: john.skidmore@alaska.gov

Third Judicial District: Anchorage Personal Services Information				
Authorized Positions			Personal Services Costs	
	<u>FY2022</u> <u>Management</u> <u>Plan</u>	<u>FY2023</u> <u>Governor</u>		
Full-time	68	68	Annual Salaries	5,200,830
Part-time	0	0	COLA	2,566
Nonpermanent	0	0	Premium Pay	0
			Annual Benefits	3,255,549
			<i>Less 6.24% Vacancy Factor</i>	<i>(527,545)</i>
			Lump Sum Premium Pay	0
Totals	68	68	Total Personal Services	7,931,400

Position Classification Summary					
Job Class Title	Anchorage	Fairbanks	Juneau	Others	Total
Attorney 2	4	0	0	0	4
Attorney 3	16	0	0	0	16
Attorney 4	9	0	0	0	9
Attorney 5	7	0	0	0	7
Attorney 6	1	0	0	0	1
Law Office Assistant 1	12	0	0	0	12
Law Office Assistant 2	2	0	0	0	2
Law Office Manager 2	1	0	0	0	1
Office Assistant 1	2	0	0	0	2
Office Assistant 2	2	0	0	0	2
Victim/Witness Paralegal 2	12	0	0	0	12
Totals	68	0	0	0	68

Component Detail All Funds
Department of Law

Component: Third Judicial District: Anchorage (2261)
RDU: Criminal Division (33)

Non-Formula Component

	FY2021 Actuals	FY2022 Conference Committee	FY2022 Authorized	FY2022 Management Plan	FY2023 Governor	FY2022 Management Plan vs FY2023 Governor	
71000 Personal Services	7,035.6	7,831.8	7,831.8	7,897.0	7,931.4	34.4	0.4%
72000 Travel	43.0	117.4	117.4	117.4	117.4	0.0	0.0%
73000 Services	1,147.6	826.1	826.1	826.1	751.1	-75.0	-9.1%
74000 Commodities	90.4	96.2	96.2	96.2	96.2	0.0	0.0%
75000 Capital Outlay	0.0	0.0	0.0	0.0	0.0	0.0	0.0%
77000 Grants, Benefits	0.0	0.0	0.0	0.0	0.0	0.0	0.0%
78000 Miscellaneous	0.0	0.0	0.0	0.0	0.0	0.0	0.0%
Totals	8,316.6	8,871.5	8,871.5	8,936.7	8,896.1	-40.6	-0.5%
Fund Sources:							
1004 Gen Fund (UGF)	8,196.7	8,588.9	8,588.9	8,654.1	8,619.0	-35.1	-0.4%
1005 GF/Prgm (DGF)	1.5	11.0	11.0	11.0	11.0	0.0	0.0%
1007 I/A Rcpts (Other)	118.4	271.6	271.6	271.6	266.1	-5.5	-2.0%
Unrestricted General (UGF)	8,196.7	8,588.9	8,588.9	8,654.1	8,619.0	-35.1	-0.4%
Designated General (DGF)	1.5	11.0	11.0	11.0	11.0	0.0	0.0%
Other Funds	118.4	271.6	271.6	271.6	266.1	-5.5	-2.0%
Federal Funds	0.0	0.0	0.0	0.0	0.0	0.0	0.0%
Positions:							
Permanent Full Time	63	67	67	68	68	0	0.0%
Permanent Part Time	0	0	0	0	0	0	0.0%
Non Permanent	0	0	0	0	0	0	0.0%

Change Record Detail - Multiple Scenarios with Descriptions
Department of Law

Component: Third Judicial District: Anchorage (2261)
RDU: Criminal Division (33)

Scenario/Change Record Title	Trans Type	Totals	Personal Services	Travel	Services	Commodities	Capital Outlay	Grants, Benefits	Miscellaneous	Positions		NP
										PFT	PPT	
***** Changes From FY2022 Conference Committee To FY2022 Authorized *****												
FY2022 Conference Committee												
	ConfCom	8,871.5	7,831.8	117.4	826.1	96.2	0.0	0.0	0.0	67	0	0
1004 Gen Fund		8,588.9										
1005 GF/Prgm		11.0										
1007 I/A Rcpts		271.6										
Subtotal		8,871.5	7,831.8	117.4	826.1	96.2	0.0	0.0	0.0	67	0	0
***** Changes From FY2022 Authorized To FY2022 Management Plan *****												
Transfer Attorney 5 (03-1322) from Criminal Appeals/Special Litigation for Required Legal Expertise												
	Trin	65.2	65.2	0.0	0.0	0.0	0.0	0.0	0.0	1	0	0
1004 Gen Fund		65.2										
Transfer one full-time Attorney 5 position (03-1322), range 25, located in Anchorage, from Criminal Appeals/Special Litigation to the Third Judicial District: Anchorage to keep pace with the required level of legal expertise needed within the office. The remaining staff in Criminal Appeals/Special Litigation are sufficient to accommodate anticipated workload.												
Subtotal		8,936.7	7,897.0	117.4	826.1	96.2	0.0	0.0	0.0	68	0	0
***** Changes From FY2022 Management Plan To FY2023 Governor *****												
FY2023 Salary and Benefit Adjustments												
	SalAdj	1.7	1.7	0.0	0.0	0.0	0.0	0.0	0.0	0	0	0
1004 Gen Fund		1.7										
FY2023 SU BU - Supervisory Employees (SS) 1% COLA: \$1.7												
FY2023 Executive Health Insurance, SBS, and Risk Management Rate Changes												
	SalAdj	63.8	63.8	0.0	0.0	0.0	0.0	0.0	0.0	0	0	0
1004 Gen Fund		61.1										
1007 I/A Rcpts		2.7										
FY2023 Change Partially Exempt & Exempt Executive (EE) - Health Insurance from \$1,555 to \$1,685; SBS and Risk Management Rates: \$63.8												
FY2023 Supervisory Employees Health Insurance, SBS, and Risk Management Rate Changes												
	SalAdj	4.9	4.9	0.0	0.0	0.0	0.0	0.0	0.0	0	0	0
1004 Gen Fund		4.8										
1007 I/A Rcpts		0.1										
FY2023 Change Supervisory Employees (SS) - Health Insurance from \$1,555 to \$1,685; SBS and Risk Management Rates: \$4.9												

Change Record Detail - Multiple Scenarios with Descriptions
Department of Law

Component: Third Judicial District: Anchorage (2261)
RDU: Criminal Division (33)

Scenario/Change Record Title	Trans Type	Totals	Personal Services	Travel	Services	Commodities	Capital Outlay	Grants, Benefits	Miscellaneous	Positions		NP
										PFT	PPT	
FY2023 General Government Unit SBS and Risk Management Rate Changes												
1004 Gen Fund	SalAdj	3.5	3.5	0.0	0.0	0.0	0.0	0.0	0.0	0	0	0
FY2023 Change General Government Unit (GG, GP, GY, GZ) - SBS, and Risk Management Rates: \$3.5												
FY2023 PERS Actuarial Rate Adjustment to 24.79% Ch9 SLA2021 (SB55)												
1004 Gen Fund	SalAdj	-246.2	-254.5	0.0	0.0	0.0	0.0	0.0	0.0	0	0	0
1007 I/A Rcpts		-8.3										
Includes: FY2023 Adjustment for PERS ARM Board Approved Rate of 24.79% (from 30.11%): \$-254.5												
Fully Fund Positions Added in FY2022 to Combat Sexual Assault												
1004 Gen Fund	Inc	140.0	140.0	0.0	0.0	0.0	0.0	0.0	0.0	0	0	0
The Department of Law, Criminal Division added a number of full-time prosecutors and support staff positions in the FY2022 Governor's budget in order to increase the resources available to combat sexual assault and the sexual abuse of minors across Alaska. While accepted, these positions were three-quarter funded by the Legislature in the FY2022 enacted budget. This increment will fully-fund the positions and allow the department to maintain full-time employment of these positions.												
Transfer Authority from Services for Anticipated Personal Service Expenditures												
	LIT	0.0	75.0	0.0	-75.0	0.0	0.0	0.0	0.0	0	0	0
Transfer authority from the services line to the personal services line for anticipated personal services costs. The remaining services authority is anticipated to be sufficient to cover operating expenditures.												
Totals		8,896.1	7,931.4	117.4	751.1	96.2	0.0	0.0	0.0	68	0	0

Line Item Detail (1676)
Department of Law
Travel

Component: Third Judicial District: Anchorage (2261)

Line Number	Line Name		FY2021 Actuals	FY2022 Management Plan	FY2023 Governor
2000	Travel		43.0	117.4	117.4
Object Class	Servicing Agency	Explanation	FY2021 Actuals	FY2022 Management Plan	FY2023 Governor
2000 Travel Detail Totals			43.0	117.4	117.4
2000	In-State Employee Travel	Travel for attorneys to interview witnesses and attend court proceedings, as well as for necessary training for both attorneys and paraprofessionals. Includes travel for management purposes.	0.7	30.0	30.0
2001	In-State Non-Employee Travel	Travel costs for witnesses to testify in court.	6.6	52.4	52.4
2002	Out of State Employee Travel	Travel costs and expenses for out-of-state travel for conferences, training, etc.	0.0	8.0	8.0
2003	Out of State Non-Employee Travel	Travel costs and expenses for out-of-state witnesses to testify in court.	1.1	15.0	15.0
2005	Moving Costs	Moving costs.	34.6	12.0	12.0

Line Item Detail (1676)
Department of Law
Services

Component: Third Judicial District: Anchorage (2261)

Line Number	Line Name		FY2021 Actuals	FY2022 Management Plan	FY2023 Governor
3000	Services		1,147.6	826.1	751.1
Object Class	Servicing Agency	Explanation	FY2021 Actuals	FY2022 Management Plan	FY2023 Governor
3000 Services Detail Totals			1,147.6	826.1	751.1
3000	Education Services	Conferences, training and memberships.	31.6	10.0	10.0
3001	Financial Services	Bankcard service fees.	0.0	0.1	0.1
3002	Legal and Judicial Services	Depositions, research costs, expert witness and consultant fees.	37.5	25.0	25.0
3003	Information Technology	Training, consulting and software licensing and maintenance. Annual maintenance fee for mission-critical information management systems.	3.3	3.3	3.3
3004	Telecommunications	Local telephone service, long distance charges and cellular phone services paid to third-party telephone utilities.	12.1	12.1	12.1
3006	Delivery Services	Freight, courier, postage, and transportation of trial exhibit materials.	4.1	4.0	4.0
3008	Utilities	Waste management disposal costs not included in lease.	3.5	1.5	1.5
3010	Equipment/Machinery	Office equipment rental - copier and postage meters.	0.5	0.5	0.5
3011	Other Services	Cost transfers and miscellaneous items within the services line (commissions, etc.).	1.5	1.5	1.5
3013	Inter-Agency Data Processing Operations Allocation	Law - Administrative Services (2164) RSA Law, Information services, data processing investments and support.	23.5	3.5	3.5
3017	Inter-Agency Information Technology	Admin - Department-wide RSA Administration, Office of	251.5	251.5	176.5

Line Item Detail (1676)
Department of Law
Services

Component: Third Judicial District: Anchorage (2261)

Object Class	Servicing Agency	Explanation	FY2021 Actuals	FY2022 Management Plan	FY2023 Governor
3000 Services Detail Totals			1,147.6	826.1	751.1
Non-Telecommunications		Information Technology computer services.			
3018 Inter-Agency Information Technology Telecommunications	Admin - Department-wide	RSA Administration, Office of Information Technology telecommunications services.	32.9	21.7	21.7
3022 Inter-Agency Human Resources	Law - Administrative Services (2164)	RSA Law, Human Resources position.	57.1	57.1	57.1
3023 Inter-Agency Building Leases	Admin - Department-wide	Leased office space managed by General Services.	672.4	418.2	418.2
3026 Inter-Agency Insurance	Admin - Department-wide	RSA Administration, Risk Management.	4.2	4.2	4.2
3027 Inter-Agency Financial	Admin - Department-wide	RSA Administration, Finance Chargeback (IRIS).	10.2	10.2	10.2
3028 Inter-Agency Americans with Disabilities Act Compliance	Admin - Department-wide	RSA Administration - Division of Personnel and Labor Relations, Americans with Disabilities Act.	0.5	0.5	0.5
3037 State Equipment Fleet		State vehicle maintenance and operations.	1.2	1.2	1.2

Line Item Detail (1676)

**Department of Law
Commodities**

Component: Third Judicial District: Anchorage (2261)

Line Number	Line Name		FY2021 Actuals	FY2022 Management Plan	FY2023 Governor
4000	Commodities		90.4	96.2	96.2
Object Class	Servicing Agency	Explanation	FY2021 Actuals	FY2022 Management Plan	FY2023 Governor
		4000 Commodities Detail Totals	90.4	96.2	96.2
4000	Business	Reference materials and subscriptions, including statutes, software applications, non-capital desktop refresh, and miscellaneous office supplies.	90.4	96.2	96.2

Revenue Detail (1681)
Department of Law

Component: Third Judicial District: Anchorage (2261)

Revenue Type (OMB Fund Code) Revenue Source	Component	Comment	FY2021 Actuals	FY2022 Management Plan	FY2023 Governor
5005 GF/Prgm (1005 GF/Prgm)			1.5	11.0	11.0
5119 Program Receipts Law - Charges for Services		Discovery receipts - receipts from private attorneys.	1.5	11.0	11.0
5007 I/A Rcpts (1007 I/A Rcpts)			118.4	271.6	266.1
5301 Inter-Agency Receipts	Courts - Department-wide	Therapeutic Courts (Wellness Court): Participating attorneys recommend potential participants and review them for eligibility, making case-related decisions - Anchorage RSA. Program code: CM03651351.	118.4	271.6	266.1

Inter-Agency Services (1682)
Department of Law

Component: Third Judicial District: Anchorage (2261)

				FY2021 Actuals	FY2022 Management Plan	FY2023 Governor
Component Totals				1,052.3	766.9	691.9
With Department of Law				80.6	60.6	60.6
With Department of Administration				971.7	706.3	631.3
Object Class	Servicing Agency	Explanation	FY2021 Actuals	FY2022 Management Plan	FY2023 Governor	
3013	Inter-Agency Data Processing Operations Allocation	Law - Administrative Services (2164)	RSA Law, Information services, data processing investments and support.	23.5	3.5	3.5
3017	Inter-Agency Information Technology Non-Telecommunications	Admin - Department-wide	RSA Administration, Office of Information Technology computer services.	251.5	251.5	176.5
3018	Inter-Agency Information Technology Telecommunications	Admin - Department-wide	RSA Administration, Office of Information Technology telecommunications services.	32.9	21.7	21.7
3022	Inter-Agency Human Resources	Law - Administrative Services (2164)	RSA Law, Human Resources position.	57.1	57.1	57.1
3023	Inter-Agency Building Leases	Admin - Department-wide	Leased office space managed by General Services.	672.4	418.2	418.2
3026	Inter-Agency Insurance	Admin - Department-wide	RSA Administration, Risk Management.	4.2	4.2	4.2
3027	Inter-Agency Financial	Admin - Department-wide	RSA Administration, Finance Chargeback (IRIS).	10.2	10.2	10.2
3028	Inter-Agency Americans with Disabilities Act Compliance	Admin - Department-wide	RSA Administration - Division of Personnel and Labor Relations, Americans with Disabilities Act.	0.5	0.5	0.5

Personal Services Expenditure Detail
Department of Law

Scenario: FY2023 Governor (18673)
Component: Third Judicial District: Anchorage (2261)
RDU: Criminal Division (33)

PCN	Job Class Title	Time Status	Retire Code	Barg Unit	Location	Salary Sched	Range / Step	Comp Months	Split / Count	Annual Salaries	COLA	Premium Pay	Annual Benefits	Total Costs	UGF Amount
03-0100	Attorney 3	FT	A	XE	Anchorage	N00	22A / B	12.0		80,667	0	0	50,270	130,937	108,678
03-0129	Attorney 5	FT	A	XE	Anchorage	N00	25J	12.0		118,131	0	0	64,217	182,348	182,348
03-0176	Attorney 3	FT	A	XE	Anchorage	N00	22E / F	12.0		91,080	0	0	54,146	145,226	145,226
03-0352	Law Office Assistant 1	FT	A	GP	Anchorage	200	11G	12.0		45,533	0	0	35,733	81,266	81,266
03-1009	Attorney 4	FT	A	XE	Anchorage	N00	24E / F	12.0		103,703	0	0	58,846	162,549	162,549
03-1011	Attorney 2	FT	A	XE	Anchorage	N00	20E / F	12.0		79,432	0	0	49,810	129,242	129,242
03-1016	Law Office Assistant 2	FT	A	SS	Anchorage	600	13D / E	12.0		51,147	702	0	39,423	91,272	84,883
03-1024	Attorney 3	FT	A	XE	Anchorage	N00	22B / C	12.0		83,369	0	0	51,276	134,645	134,645
03-1029	Law Office Assistant 1	FT	A	GP	Anchorage	200	11B / C	12.0		39,516	0	0	33,493	73,009	73,009
03-1031	Attorney 3	FT	A	XE	Anchorage	N00	22A / B	12.0		80,667	0	0	50,270	130,937	130,937
03-1035	Attorney 3	FT	A	XE	Anchorage	N00	22B / C	12.0		82,079	0	0	50,795	132,874	132,874
03-1048	Law Office Assistant 1	FT	A	GP	Anchorage	200	11C / D	12.0		40,739	0	0	33,948	74,687	74,687
03-1049	Office Assistant 1	FT	A	GP	Anchorage	200	8B / C	12.0		32,624	0	0	30,927	63,551	63,551
03-1052	Victim/Witness Paralegal 2	FT	A	GP	Anchorage	200	16A / B	12.0		53,355	0	0	38,645	92,000	92,000
03-1053	Office Assistant 1	FT	A	GP	Anchorage	200	8E / F	12.0		35,900	0	0	32,147	68,047	68,047
03-1054	Attorney 4	FT	A	XE	Anchorage	N00	24C / D	12.0		98,462	0	0	56,895	155,357	155,357
03-1062	Law Office Assistant 2	FT	A	SS	Anchorage	99	13S / T	12.0		77,108	1,058	0	49,089	127,255	127,255
03-1067	Law Office Assistant 1	FT	A	GP	Anchorage	200	11E / F	12.0		42,938	0	0	34,767	77,705	69,935
03-1071	Law Office Assistant 1	FT	A	GP	Anchorage	200	11F / G	12.0		44,168	0	0	35,225	79,393	79,393
03-1094	Attorney 4	FT	A	XE	Anchorage	N00	24E / F	12.0		103,529	0	0	58,781	162,310	162,310
03-1100	Attorney 5	FT	A	XE	Anchorage	N00	25O	12.0		138,626	0	0	71,848	210,474	157,856
03-1102	Law Office Manager 2	FT	A	SS	Anchorage	200	16A / B	12.0		58,718	806	0	42,242	101,766	101,766
03-1106	Attorney 3	FT	A	XE	Anchorage	N00	22E / F	12.0		90,007	0	0	53,747	143,754	143,754
03-1112	Attorney 3	FT	A	XE	Anchorage	N00	22J	12.0		95,979	0	0	55,970	151,949	151,949
03-1132	Victim/Witness Paralegal 2	FT	A	GG	Anchorage	99	16N	12.0		77,747	0	0	47,727	125,474	125,474
03-1133	Victim/Witness Paralegal 2	FT	A	GP	Anchorage	200	16F / G	12.0		63,632	0	0	42,472	106,104	106,104
03-1137	Victim/Witness Paralegal 2	FT	A	GP	Anchorage	200	16A / B	12.0		54,119	0	0	38,930	93,049	93,049
03-1148	Attorney 3	FT	A	XE	Anchorage	N00	22F	12.0		92,957	0	0	54,845	147,802	147,802
03-1150	Attorney 3	FT	A	XE	Anchorage	N00	22C / D	12.0		86,424	0	0	52,413	138,837	138,837
03-1162	Law Office Assistant 1	FT	A	GP	Anchorage	99	11N	12.0		53,625	0	0	38,746	92,371	92,371
03-1170	Office Assistant 2	FT	A	GP	Anchorage	200	10B / C	12.0		36,806	0	0	32,484	69,290	69,290
03-1179	Attorney 6	FT	A	XE	Anchorage	N00	26M	12.0		134,687	0	0	70,381	205,068	205,068
03-1188	Office Assistant 2	FT	A	GP	Anchorage	200	10B / C	12.0		37,697	0	0	32,816	70,513	70,513
03-1192	Victim/Witness Paralegal 2	FT	A	GP	Anchorage	200	16C / D	12.0		57,933	0	0	40,350	98,283	98,283
03-1194	Attorney 2	FT	A	XE	Anchorage	N00	20E / F	12.0		81,030	0	0	50,405	131,435	131,435
03-1222	Attorney 5	FT	A	XE	Anchorage	N00	25J	12.0		118,131	0	0	64,217	182,348	182,348
03-1233	Attorney 2	FT	A	XE	Anchorage	N00	20C / D	12.0		74,236	0	0	47,875	122,111	122,111
03-1235	Attorney 3	FT	A	XE	Anchorage	N00	22E / F	12.0		92,233	0	0	54,576	146,809	0

Note: If a position is split, an asterisk (*) will appear in the Split/Count column. If the split position is also counted in the component, two asterisks (**) will appear in this column. [No valid job title] appearing in the Job Class Title indicates that the PCN has an invalid class code or invalid range for the class code effective date of this scenario.

Personal Services Expenditure Detail
Department of Law

Scenario: FY2023 Governor (18673)
Component: Third Judicial District: Anchorage (2261)
RDU: Criminal Division (33)

PCN	Job Class Title	Time Status	Retire Code	Barg Unit	Location	Salary Sched	Range / Step	Comp Months	Split / Count	Annual Salaries	COLA	Premium Pay	Annual Benefits	Total Costs	UGF Amount
03-1236	Law Office Assistant 1	FT	A	GP	Anchorage	200	11D / E	12.0		42,493	0	0	34,601	77,094	77,094
03-1241	Attorney 4	FT	A	XE	Anchorage	99	24M	12.0		122,157	0	0	65,716	187,873	187,873
03-1242	Victim/Witness Paralegal 2	FT	A	GP	Anchorage	200	16B / C	12.0		54,929	0	0	39,231	94,160	94,160
03-1245	Victim/Witness Paralegal 2	FT	N	GP	Anchorage	200	16G / J	12.0		66,640	0	0	27,071	93,711	93,711
03-1249	Attorney 4	FT	A	XE	Anchorage	N00	24J / K	12.0		112,294	0	0	62,044	174,338	174,338
03-1255	Attorney 3	FT	A	XE	Anchorage	N00	22D / E	12.0		87,165	0	0	52,689	139,854	116,079
03-1258	Law Office Assistant 1	FT	A	GP	Anchorage	200	11D / E	12.0		41,743	0	0	34,322	76,065	70,741
03-1259	Attorney 4	FT	A	XE	Anchorage	N00	24D / E	12.0		101,875	0	0	58,165	160,040	160,040
03-1262	Attorney 4	FT	A	XE	Anchorage	N00	24F	12.0		106,451	0	0	59,869	166,320	166,320
03-1264	Attorney 2	FT	A	XE	Anchorage	N00	20D / E	12.0		76,762	0	0	48,816	125,578	125,578
03-1265	Attorney 4	FT	A	XE	Anchorage	N00	24E	12.0		102,980	0	0	58,577	161,557	161,557
03-1268	Victim/Witness Paralegal 2	FT	A	GP	Anchorage	200	16A / B	12.0		53,193	0	0	38,585	91,778	91,778
03-1270	Law Office Assistant 1	FT	A	GP	Anchorage	200	11C / D	12.0		40,565	0	0	33,884	74,449	74,449
03-1281	Attorney 3	FT	A	XE	Anchorage	N00	22C / D	12.0		86,551	0	0	52,460	139,011	139,011
03-1284	Attorney 4	FT	A	XE	Anchorage	N00	24F	12.0		106,451	0	0	59,869	166,320	166,320
03-1285	Victim/Witness Paralegal 2	FT	A	GP	Anchorage	200	16E / F	12.0		61,523	0	0	41,686	103,209	103,209
03-1299	Attorney 5	FT	A	XE	Anchorage	N00	25M	12.0		130,026	0	0	68,646	198,672	198,672
03-1317	Attorney 3	FT	A	XE	Anchorage	N00	22E / F	12.0		92,367	0	0	54,626	146,993	146,993
03-1318	Attorney 3	FT	A	XE	Anchorage	N00	22E / F	12.0		92,233	0	0	54,576	146,809	146,809
03-1322	Attorney 5	FT	A	XE	Anchorage	N00	25C / D	12.0		105,727	0	0	59,599	165,326	165,326
03-1327	Victim/Witness Paralegal 2	FT	A	GP	Anchorage	200	16G / J	12.0		65,505	0	0	43,169	108,674	108,674
03-1328	Law Office Assistant 1	FT	A	GP	Anchorage	200	11B / C	12.0		38,988	0	0	33,297	72,285	72,285
03-1331	Victim/Witness Paralegal 2	FT	A	GP	Anchorage	200	16B / C	12.0		55,854	0	0	39,576	95,430	95,430
03-1332	Attorney 3	FT	A	XE	Anchorage	N00	22F / J	12.0		93,208	0	0	54,939	148,147	148,147
03-1333	Attorney 3	FT	A	XE	Anchorage	N00	22C / D	12.0		86,424	0	0	52,413	138,837	138,837
03-1352	Law Office Assistant 1	FT	A	GP	Anchorage	200	11B / C	12.0		39,063	0	0	33,324	72,387	72,387
03-1357	Victim/Witness Paralegal 2	FT	A	GP	Anchorage	200	16A / B	12.0		53,274	0	0	38,615	91,889	91,889
03-1363	Attorney 5	FT	A	XE	Anchorage	N00	25D / E	12.0		108,220	0	0	60,528	168,748	168,748
03-1364	Attorney 5	FT	A	XE	Anchorage	N00	25D / E	12.0		108,220	0	0	60,528	168,748	168,748
03-1372	Law Office Assistant 1	FT	A	GP	Anchorage	100	11A / B	12.0		39,215	0	0	33,381	72,596	72,596

Note: If a position is split, an asterisk (*) will appear in the Split/Count column. If the split position is also counted in the component, two asterisks (**) will appear in this column. [No valid job title] appearing in the Job Class Title indicates that the PCN has an invalid class code or invalid range for the class code effective date of this scenario.

Personal Services Expenditure Detail
Department of Law

Scenario: FY2023 Governor (18673)
Component: Third Judicial District: Anchorage (2261)
RDU: Criminal Division (33)

PCN	Job Class Title	Time Status	Retire Code	Barg Unit	Location	Salary Sched	Range / Step	Comp Months	Split / Count	Annual Salaries	COLA	Premium Pay	Annual Benefits	Total Costs	UGF Amount
		Total Positions	New	Deleted										Total Salary Costs:	5,200,830
														Total COLA:	2,566
	Full Time Positions:	68	0	0										Total Premium Pay:	0
	Part Time Positions:	0	0	0										Total Benefits:	3,255,549
	Non Permanent Positions:	0	0	0											
	Positions in Component:	68	0	0											
	Total Component Months:	816.0												Total Pre-Vacancy:	8,458,945
														Minus Vacancy Adjustment of 6.24%:	(527,545)
														Total Post-Vacancy:	7,931,400
														Plus Lump Sum Premium Pay:	0
														Personal Services Line 100:	7,931,400

PCN Funding Sources:	Pre-Vacancy	Post-Vacancy	Percent
1004 General Fund Receipts	8,193,999	7,682,977	96.87%
1007 Interagency Receipts	264,946	248,423	3.13%
Total PCN Funding:	8,458,945	7,931,400	100.00%

Note: If a position is split, an asterisk (*) will appear in the Split/Count column. If the split position is also counted in the component, two asterisks (**) will appear in this column. [No valid job title] appearing in the Job Class Title indicates that the PCN has an invalid class code or invalid range for the class code effective date of this scenario.

CRIMINAL DIVISION

Third Judicial District: Anchorage 1 of 2

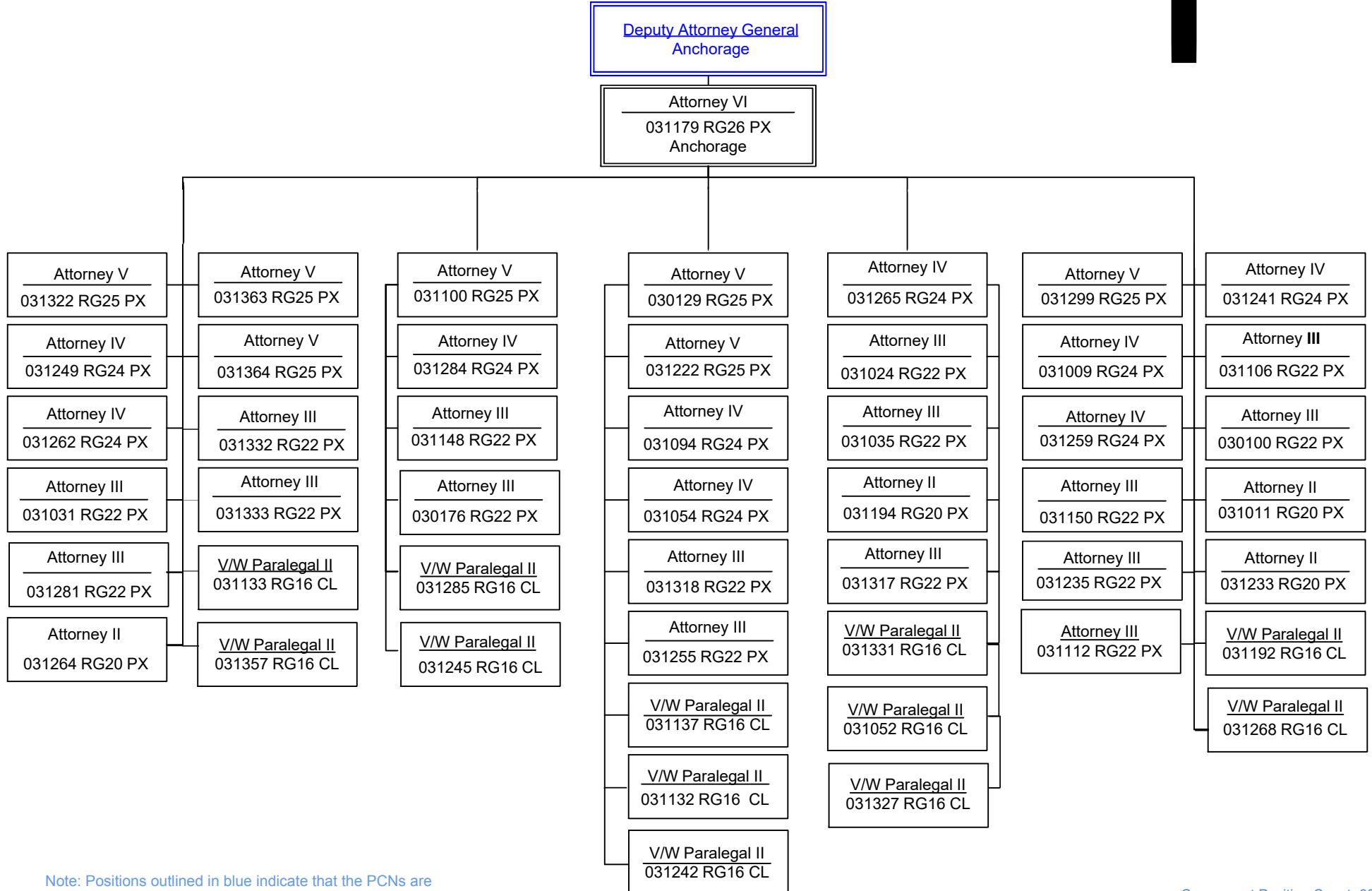

Note: Positions outlined in blue indicate that the PCNs are counted elsewhere but shown here to indicate organizational hierarchy.

CRIMINAL DIVISION

Third Judicial District: Anchorage 2 of 2

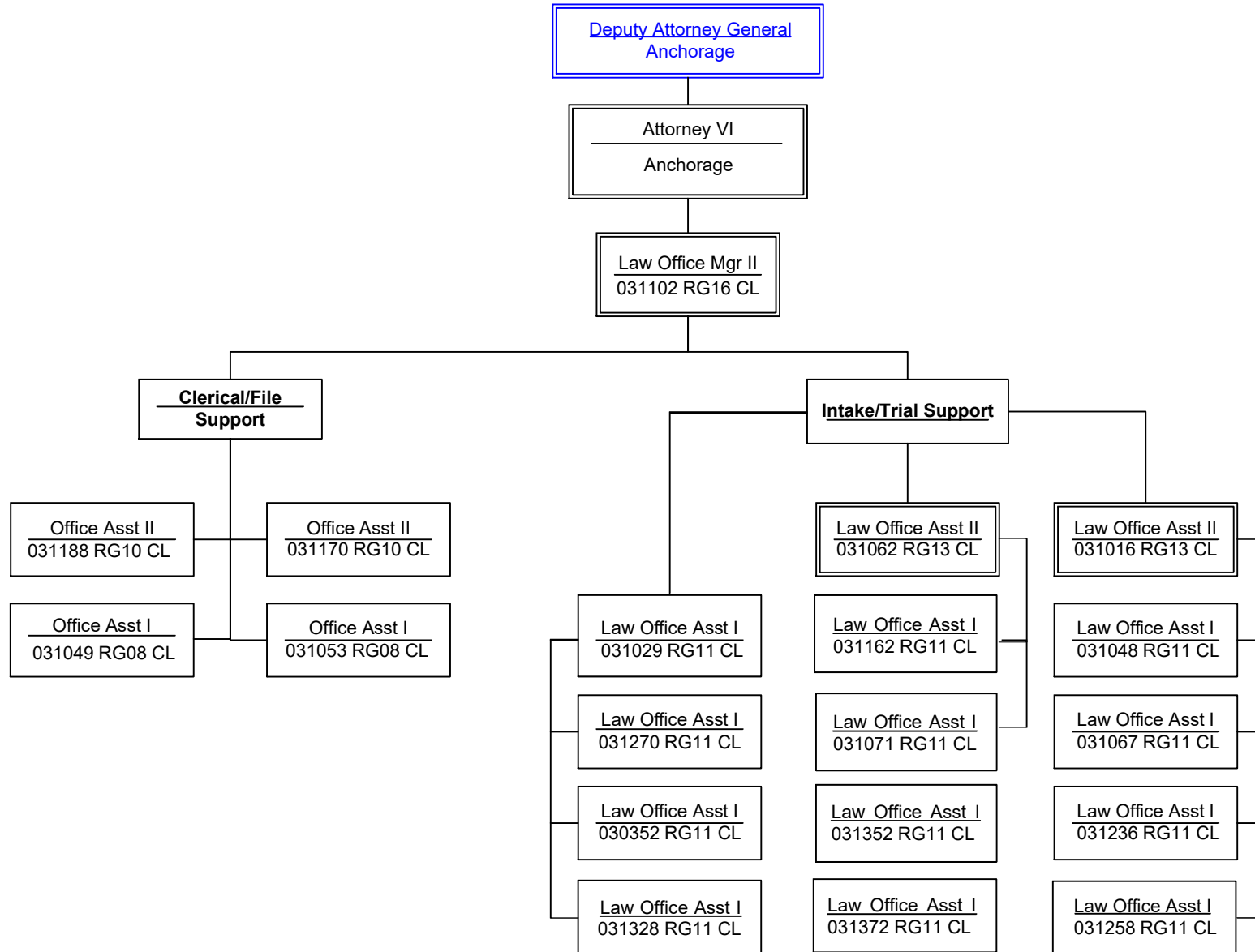

**State of Alaska
FY2023 Governor's Operating Budget**

**Department of Law
Third Judicial District: Outside Anchorage
Component Budget Summary**

Component: Third Judicial District: Outside Anchorage

Contribution to Department's Mission

This component contributes to the department's mission by prosecuting and convicting criminal offenders within the Third Judicial District outside of the Anchorage area (Southcentral Alaska).

Core Services

- Prosecutes violations of state criminal law by both adults and juveniles in the Third Judicial District: Outside Anchorage.
- Provides day-to-day advice to state and local law enforcement agencies conducting criminal investigations and serves as legal advisor to grand juries.
- Handles probation revocation actions, all sentence and sufficiency of evidence appeals and most post-conviction relief proceedings.
- Participates in specialized court and probation programs.
- Provides victim-witness assistance services such as: information on court procedures required by statute and the Alaska Constitution; applying for restitution; arrangement of travel and payment for expenses and court-mandated witness fees; assistance with domestic violence orders and violent crimes compensation procedures; and preparation of victims and witnesses to testify in court.

Major Component Accomplishments in 2021

See Accomplishments at RDU level.

Key Component Challenges

See Key Challenges at RDU level.

Significant Changes in Results to be Delivered in FY2023

See Changes in Results at RDU level.

Statutory and Regulatory Authority

AS 44.23.020

Contact Information

Contact: John Skidmore, Deputy Attorney General
Phone: (907) 269-5100
E-mail: john.skidmore@alaska.gov

Third Judicial District: Outside Anchorage Personal Services Information				
Authorized Positions			Personal Services Costs	
	<u>FY2022</u> <u>Management</u> <u>Plan</u>	<u>FY2023</u> <u>Governor</u>		
Full-time	48	48	Annual Salaries	3,812,563
Part-time	0	0	COLA	1,450
Nonpermanent	0	0	Premium Pay	0
			Annual Benefits	2,358,055
			<i>Less 4.58% Vacancy Factor</i>	<i>(282,668)</i>
			Lump Sum Premium Pay	0
Totals	48	48	Total Personal Services	5,889,400

Position Classification Summary					
Job Class Title	Anchorage	Fairbanks	Juneau	Others	Total
Attorney 2	0	0	0	2	2
Attorney 3	0	0	0	9	9
Attorney 4	0	0	0	5	5
Attorney 5	0	0	0	6	6
Attorney 6	0	0	0	2	2
Law Office Assistant 1	0	0	0	9	9
Law Office Assistant 2	0	0	0	2	2
Office Assistant 1	0	0	0	1	1
Office Assistant 2	0	0	0	2	2
Victim/Witness Paralegal 1	0	0	0	1	1
Victim/Witness Paralegal 2	0	0	0	9	9
Totals	0	0	0	48	48

Component Detail All Funds
Department of Law

Component: Third Judicial District: Outside Anchorage (2279)
RDU: Criminal Division (33)

Non-Formula Component

	FY2021 Actuals	FY2022 Conference Committee	FY2022 Authorized	FY2022 Management Plan	FY2023 Governor	FY2022 Management Plan vs FY2023 Governor	
71000 Personal Services	5,084.1	5,964.2	5,964.2	5,964.2	5,889.4	-74.8	-1.3%
72000 Travel	20.5	191.8	191.8	191.8	191.8	0.0	0.0%
73000 Services	532.8	252.7	252.7	252.7	302.7	50.0	19.8%
74000 Commodities	48.7	28.1	28.1	28.1	28.1	0.0	0.0%
75000 Capital Outlay	0.0	0.0	0.0	0.0	0.0	0.0	0.0%
77000 Grants, Benefits	0.0	0.0	0.0	0.0	0.0	0.0	0.0%
78000 Miscellaneous	0.0	0.0	0.0	0.0	0.0	0.0	0.0%
Totals	5,686.1	6,436.8	6,436.8	6,436.8	6,412.0	-24.8	-0.4%
Fund Sources:							
1004 Gen Fund (UGF)	5,544.7	6,267.2	6,267.2	6,267.2	6,263.7	-3.5	-0.1%
1005 GF/Prgm (DGF)	4.7	6.0	6.0	6.0	6.0	0.0	0.0%
1007 I/A Rcpts (Other)	136.7	145.9	145.9	145.9	142.3	-3.6	-2.5%
1108 Stat Desig (Other)	0.0	17.7	17.7	17.7	0.0	-17.7	-100.0%
Unrestricted General (UGF)	5,544.7	6,267.2	6,267.2	6,267.2	6,263.7	-3.5	-0.1%
Designated General (DGF)	4.7	6.0	6.0	6.0	6.0	0.0	0.0%
Other Funds	136.7	163.6	163.6	163.6	142.3	-21.3	-13.0%
Federal Funds	0.0	0.0	0.0	0.0	0.0	0.0	0.0%
Positions:							
Permanent Full Time	45	48	48	48	48	0	0.0%
Permanent Part Time	0	0	0	0	0	0	0.0%
Non Permanent	0	0	0	0	0	0	0.0%

Change Record Detail - Multiple Scenarios with Descriptions
Department of Law

Component: Third Judicial District: Outside Anchorage (2279)
RDU: Criminal Division (33)

Scenario/Change Record Title	Trans Type	Totals	Personal Services	Travel	Services	Commodities	Capital Outlay	Grants, Benefits	Miscellaneous	Positions		NP
										PFT	PPT	
***** Changes From FY2022 Conference Committee To FY2022 Authorized *****												
FY2022 Conference Committee												
	ConfCom	6,436.8	5,964.2	191.8	252.7	28.1	0.0	0.0	0.0	48	0	0
1004 Gen Fund		6,267.2										
1005 GF/Prgm		6.0										
1007 I/A Rcpts		145.9										
1108 Stat Desig		17.7										
Subtotal		6,436.8	5,964.2	191.8	252.7	28.1	0.0	0.0	0.0	48	0	0
***** Changes From FY2022 Management Plan To FY2023 Governor *****												
FY2023 Salary and Benefit Adjustments												
	SalAdj	1.5	1.5	0.0	0.0	0.0	0.0	0.0	0.0	0	0	0
1004 Gen Fund		1.5										
FY2023 SU BU - Supervisory Employees (SS) 1% COLA: \$1.5												
FY2023 Executive Health Insurance, SBS, and Risk Management Rate Changes												
	SalAdj	43.4	43.4	0.0	0.0	0.0	0.0	0.0	0.0	0	0	0
1004 Gen Fund		42.1										
1007 I/A Rcpts		1.3										
FY2023 Change Partially Exempt & Exempt Executive (EE) - Health Insurance from \$1,555 to \$1,685; SBS and Risk Management Rates: \$43.4												
FY2023 Supervisory Employees Health Insurance, SBS, and Risk Management Rate Changes												
	SalAdj	3.3	3.3	0.0	0.0	0.0	0.0	0.0	0.0	0	0	0
1004 Gen Fund		3.3										
FY2023 Change Supervisory Employees (SS) - Health Insurance from \$1,555 to \$1,685; SBS and Risk Management Rates: \$3.3												
FY2023 General Government Unit SBS and Risk Management Rate Changes												
	SalAdj	3.1	3.1	0.0	0.0	0.0	0.0	0.0	0.0	0	0	0
1004 Gen Fund		3.1										
FY2023 Change General Government Unit (GG, GP, GY, GZ) - SBS, and Risk Management Rates: \$3.1												
FY2023 PERS Actuarial Rate Adjustment to 24.79% Ch9 SLA2021 (SB55)												
	SalAdj	-195.3	-195.3	0.0	0.0	0.0	0.0	0.0	0.0	0	0	0
1004 Gen Fund		-190.4										
1007 I/A Rcpts		-4.9										

Change Record Detail - Multiple Scenarios with Descriptions
Department of Law

Component: Third Judicial District: Outside Anchorage (2279)
RDU: Criminal Division (33)

Scenario/Change Record Title	Trans Type	Totals	Personal Services	Travel	Services	Commodities	Capital Outlay	Grants, Benefits	Miscellaneous	Positions		
										PFT	PPT	NP
Includes: FY2023 Adjustment for PERS ARM Board Approved Rate of 24.79% (from 30.11%): \$-195.3												
Fully Fund Positions Added in FY2022 to Combat Sexual Assault												
	Inc	119.2	119.2	0.0	0.0	0.0	0.0	0.0	0.0	0	0	0
1004 Gen Fund		119.2										
The Department of Law, Criminal Division added a number of full-time prosecutors and support staff positions in the FY2022 Governor's budget in order to increase the resources available to combat sexual assault and the sexual abuse of minors across Alaska. While accepted, these positions were three-quarter funded by the Legislature in the FY2022 enacted budget. This increment will fully-fund the positions and allow the department to maintain full-time employment of these positions.												
Realign PERS Rate Adjustment by Fund Source Ch9 SLA2021 (SB55)												
	FndChg	0.0	0.0	0.0	0.0	0.0	0.0	0.0	0.0	0	0	0
1004 Gen Fund		17.7										
1108 Stat Desig		-17.7										
Replace unrealizable SDPR authority assigned in SB55 fiscal note (Ch 9 SLA 2021).												
Transfer Authority to Services Anticipated Expenditures												
	LIT	0.0	-50.0	0.0	50.0	0.0	0.0	0.0	0.0	0	0	0
Transfer authority to the services line from the personal services line from for anticipated costs. The remaining personal services authority is anticipated to be sufficient to cover operating expenditures.												
Totals		6,412.0	5,889.4	191.8	302.7	28.1	0.0	0.0	0.0	48	0	0

Line Item Detail (1676)
Department of Law
Travel

Component: Third Judicial District: Outside Anchorage (2279)

Line Number	Line Name		FY2021 Actuals	FY2022 Management Plan	FY2023 Governor
2000	Travel		20.5	191.8	191.8
Object Class	Servicing Agency	Explanation	FY2021 Actuals	FY2022 Management Plan	FY2023 Governor
2000 Travel Detail Totals			20.5	191.8	191.8
2000	In-State Employee Travel	Travel for attorneys to interview witnesses and attend court proceedings, as well as for necessary training for both attorneys and paraprofessionals. Includes travel for management purposes.	7.0	80.0	80.0
2001	In-State Non-Employee Travel	Travel costs for witnesses to testify in court.	5.4	80.0	80.0
2002	Out of State Employee Travel	Travel costs and expenses for out-of-state travel for conferences, training, etc.	1.3	9.0	9.0
2003	Out of State Non-Employee Travel	Travel costs and expenses for out-of-state witnesses to testify in court.	0.8	10.8	10.8
2005	Moving Costs	Moving costs.	6.0	12.0	12.0

Line Item Detail (1676)
Department of Law
Services

Component: Third Judicial District: Outside Anchorage (2279)

Line Number	Line Name		FY2021 Actuals	FY2022 Management Plan	FY2023 Governor
3000	Services		532.8	252.7	302.7
Object Class	Servicing Agency	Explanation	FY2021 Actuals	FY2022 Management Plan	FY2023 Governor
3000 Services Detail Totals			532.8	252.7	302.7
3000	Education Services	Conferences, training and memberships.	16.6	1.0	1.0
3002	Legal and Judicial Services	Depositions, research costs, expert witness and consultant fees.	28.4	2.8	28.0
3003	Information Technology	Training, consulting and software licensing and maintenance. Annual maintenance fee for mission-critical information management systems.	6.0	1.6	6.0
3004	Telecommunications	Local telephone service, long distance charges and cellular phone services paid to third-party telephone utilities.	55.3	16.0	55.0
3006	Delivery Services	Freight, courier, postage, and transportation of trial exhibit materials.	1.6	1.6	1.6
3008	Utilities	Waste management disposal costs not included in lease.	6.2	4.2	6.2
3009	Structure/Infrastructure/Land	Rentals/leases - records and evidence storage.	6.8	2.8	6.8
3011	Other Services	Cost transfers and miscellaneous items within the services line (commissions, etc.).	3.4	0.4	0.4
3013	Inter-Agency Data Processing Operations Allocation	Law - Administrative Services (2164) RSA Law, Information services, data processing investments and support.	16.9	16.9	16.9
3017	Inter-Agency Information Technology Non-Telecommunications	Admin - Department-wide RSA Administration, Office of Information Technology computer services.	179.6	75.8	80.0

Line Item Detail (1676)
Department of Law
Services

Component: Third Judicial District: Outside Anchorage (2279)

Object Class		Servicing Agency	Explanation	FY2021 Actuals	FY2022 Management Plan	FY2023 Governor
3000 Services Detail Totals				532.8	252.7	302.7
3018	Inter-Agency Information Technology Telecommunications	Admin - Department-wide	RSA Administration, Office of Information Technology telecommunications services.	23.6	9.4	24.0
3022	Inter-Agency Human Resources	Law - Administrative Services (2164)	RSA Law, Human Resources position.	40.7	6.1	31.8
3023	Inter-Agency Building Leases	Admin - Department-wide	Leased office space managed by General Services.	129.0	100.2	30.0
3026	Inter-Agency Insurance	Admin - Department-wide	RSA Administration, Risk Management.	3.0	1.9	3.0
3027	Inter-Agency Financial	Admin - Department-wide	RSA Administration, Finance Chargeback (IRIS).	7.3	7.2	7.2
3028	Inter-Agency Americans with Disabilities Act Compliance	Admin - Department-wide	RSA Administration - Division of Personnel and Labor Relations, Americans with Disabilities Act.	0.4	0.3	0.3
3038	Inter-Agency Management/Consulting	Law - Administrative Services (2164)	RSA Law, Information services, project and management support.	8.0	4.5	4.5

Line Item Detail (1676)

**Department of Law
Commodities**

Component: Third Judicial District: Outside Anchorage (2279)

Line Number	Line Name		FY2021 Actuals	FY2022 Management Plan	FY2023 Governor
4000	Commodities		48.7	28.1	28.1
Object Class	Servicing Agency	Explanation	FY2021 Actuals	FY2022 Management Plan	FY2023 Governor
4000 Commodities Detail Totals			48.7	28.1	28.1
4000	Business	Reference materials and subscriptions, including statutes, software applications, non-capital desktop refresh, and miscellaneous office supplies.	48.1	26.1	26.1
4002	Household/Institutional	Institutional supplies for cleaning and maintenance.	0.4	1.0	1.0
4004	Safety	Safety and security purchases.	0.2	1.0	1.0

Revenue Detail (1681)
Department of Law

Component: Third Judicial District: Outside Anchorage (2279)

Revenue Type (OMB Fund Code) Revenue Source	Component	Comment	FY2021 Actuals	FY2022 Management Plan	FY2023 Governor
5005 GF/Prgm (1005 GF/Prgm)			4.7	6.0	6.0
5119 Program Receipts Law - Charges for Services		Discovery services - receipts from private attorneys.	4.7	6.0	6.0
5007 I/A Rcpts (1007 I/A Rcpts)			136.7	145.9	142.3
5301 Inter-Agency Receipts	Courts - Department-wide	Therapeutic Courts (Wellness Court): Participating attorneys recommend potential participants and review them for eligibility, making case-related decisions - Palmer RSA. Program code: CM03651391.	69.2	80.0	76.3
5301 Inter-Agency Receipts	Courts - Department-wide	Therapeutic Courts (Wellness Court): Participating attorneys recommend potential participants and review them for eligibility, making case-related decisions - Kenai RSA. Program code: CM03651341.	67.5	65.9	66.0
5108 Stat Desig (1108 Stat Desig)			0.0	17.7	0.0
5206 Statutory Designated Program Receipts - Contracts		Uncollectible state designated program receipt authority.	0.0	17.7	0.0
6004 Gen Fund (1004 Gen Fund)			1.4	0.0	0.0
6046 General Fund - Prior Year Reimbursement Recovery		Prior year recovery	1.4	0.0	0.0

Inter-Agency Services (1682)
Department of Law

Component: Third Judicial District: Outside Anchorage (2279)

				FY2021 Actuals	FY2022 Management Plan	FY2023 Governor
Component Totals				408.5	222.3	197.7
With Department of Law				65.6	27.5	53.2
With Department of Administration				342.9	194.8	144.5
Object Class	Servicing Agency	Explanation	FY2021 Actuals	FY2022 Management Plan	FY2023 Governor	
3013	Inter-Agency Data Processing Operations Allocation	Law - Administrative Services (2164)	RSA Law, Information services, data processing investments and support.	16.9	16.9	16.9
3017	Inter-Agency Information Technology Non-Telecommunications	Admin - Department-wide	RSA Administration, Office of Information Technology computer services.	179.6	75.8	80.0
3018	Inter-Agency Information Technology Telecommunications	Admin - Department-wide	RSA Administration, Office of Information Technology telecommunications services.	23.6	9.4	24.0
3022	Inter-Agency Human Resources	Law - Administrative Services (2164)	RSA Law, Human Resources position.	40.7	6.1	31.8
3023	Inter-Agency Building Leases	Admin - Department-wide	Leased office space managed by General Services.	129.0	100.2	30.0
3026	Inter-Agency Insurance	Admin - Department-wide	RSA Administration, Risk Management.	3.0	1.9	3.0
3027	Inter-Agency Financial	Admin - Department-wide	RSA Administration, Finance Chargeback (IRIS).	7.3	7.2	7.2
3028	Inter-Agency Americans with Disabilities Act Compliance	Admin - Department-wide	RSA Administration - Division of Personnel and Labor Relations, Americans with Disabilities Act.	0.4	0.3	0.3
3038	Inter-Agency Management/Consulting	Law - Administrative Services (2164)	RSA Law, Information services, project and management support.	8.0	4.5	4.5

Personal Services Expenditure Detail
Department of Law

Scenario: FY2023 Governor (18673)
Component: Third Judicial District: Outside Anchorage (2279)
RDU: Criminal Division (33)

PCN	Job Class Title	Time Status	Retire Code	Barg Unit	Location	Salary Sched	Range / Step	Comp Months	Split / Count	Annual Salaries	COLA	Premium Pay	Annual Benefits	Total Costs	UGF Amount
03-0198	Attorney 3	FT	A	XE	Palmer	N00	22F / J	12.0		95,601	0	0	55,830	151,431	113,573
03-1020	Office Assistant 2	FT	A	GP	Palmer	200	10B / C	12.0		37,820	0	0	32,862	70,682	70,682
03-1032	Attorney 4	FT	A	XE	Palmer	N00	24K	12.0		113,490	0	0	62,490	175,980	175,980
03-1033	Attorney 5	FT	A	XE	Kenai	N00	25L / M	12.0		128,934	0	0	68,239	197,173	197,173
03-1041	Attorney 4	FT	A	XE	Palmer	N00	24J / K	12.0		110,052	0	0	61,210	171,262	171,262
03-1044	Attorney 6	FT	A	XE	Kenai	N00	26S	12.0		163,196	0	0	79,984	243,180	194,544
03-1046	Law Office Assistant 2	FT	A	SS	Kenai	600	13E / F	12.0		53,774	738	0	40,401	94,913	94,913
03-1059	Attorney 3	FT	A	XE	Palmer	N00	22D / E	12.0		88,218	0	0	53,081	141,299	141,299
03-1066	Attorney 5	FT	A	XE	Kodiak	N11	25M	12.0		144,339	0	0	73,975	218,314	218,314
03-1074	Law Office Assistant 1	FT	A	GP	Kenai	200	11D / E	12.0		42,378	0	0	34,559	76,937	76,937
03-1078	Attorney 3	FT	A	XE	Kodiak	N11	22D / E	12.0		96,617	0	0	56,208	152,825	152,825
03-1097	Attorney 3	FT	A	XE	Kenai	N00	22F	12.0		92,957	0	0	54,845	147,802	147,802
03-1109	Attorney 2	FT	A	XE	Dillingham	N37	20D / E	12.0		105,168	0	0	59,391	164,559	164,559
03-1113	Office Assistant 1	FT	A	GP	Kenai	200	8A / B	12.0		32,127	0	0	30,742	62,869	62,869
03-1122	Victim/Witness Paralegal 2	FT	A	GP	Kenai	200	16B / C	12.0		54,755	0	0	39,167	93,922	93,922
03-1138	Victim/Witness Paralegal 2	FT	A	GP	Kodiak	211	16J	12.0		74,588	0	0	46,550	121,138	121,138
03-1159	Attorney 6	FT	A	XE	Palmer	N00	26D / E	12.0		113,740	0	0	62,583	176,323	176,323
03-1165	Law Office Assistant 2	FT	A	SS	Palmer	600	13D / E	12.0		51,910	712	0	39,707	92,329	92,329
03-1183	Attorney 3	FT	A	XE	Palmer	N00	22F	12.0		92,957	0	0	54,845	147,802	147,802
03-1193	Law Office Assistant 1	FT	A	GP	Dillingham	237	11J / K	12.0		66,203	0	0	43,429	109,632	109,632
03-1195	Attorney 3	FT	A	XE	Kenai	N00	22B / C	12.0		83,369	0	0	51,276	134,645	134,645
03-1199	Victim/Witness Paralegal 2	FT	A	GP	Palmer	200	16N	12.0		76,362	0	0	47,211	123,573	123,573
03-1205	Victim/Witness Paralegal 2	FT	A	GP	Palmer	200	16C / D	12.0		56,250	0	0	39,723	95,973	95,973
03-1221	Attorney 5	FT	A	XE	Palmer	N00	25K	12.0		121,973	0	0	65,648	187,621	187,621
03-1224	Office Assistant 2	FT	A	GP	Kenai	200	10B / C	12.0		37,328	0	0	32,679	70,007	70,007
03-1226	Victim/Witness Paralegal 2	FT	A	GP	Kenai	99	16P	12.0		83,607	0	0	49,908	133,515	133,515
03-1234	Attorney 3	FT	A	XE	Palmer	N00	22C / D	12.0		85,435	0	0	52,045	137,480	137,480
03-1237	Law Office Assistant 1	FT	A	GP	Palmer	200	11C / D	12.0		40,770	0	0	33,960	74,730	69,499
03-1272	Attorney 4	FT	A	XE	Palmer	N00	24K / L	12.0		115,855	0	0	63,370	179,225	148,757
03-1275	Attorney 4	FT	A	XE	Kenai	N00	24K	12.0		113,490	0	0	62,490	175,980	175,980
03-1276	Law Office Assistant 1	FT	A	GP	Kenai	200	11D / E	12.0		41,293	0	0	34,155	75,448	75,448
03-1287	Attorney 4	FT	A	XE	Kenai	N00	24B / C	12.0		94,507	0	0	55,422	149,929	149,929
03-1288	Victim/Witness Paralegal 2	FT	A	GP	Kenai	200	16D / E	12.0		58,376	0	0	40,515	98,891	98,891
03-1289	Law Office Assistant 1	FT	A	GP	Kenai	200	11B / C	12.0		39,865	0	0	33,623	73,488	66,139
03-1291	Victim/Witness Paralegal 2	FT	A	GP	Palmer	200	16D / E	12.0		59,846	0	0	41,062	100,908	100,908
03-1292	Law Office Assistant 1	FT	A	GP	Palmer	200	11E / F	12.0		43,646	0	0	35,031	78,677	78,677
03-1294	Attorney 2	FT	A	XE	Palmer	N00	20C / D	12.0		74,123	0	0	47,833	121,956	121,956
03-1306	Attorney 5	FT	A	XE	Kenai	N00	25K	12.0		121,973	0	0	65,648	187,621	187,621

Note: If a position is split, an asterisk (*) will appear in the Split/Count column. If the split position is also counted in the component, two asterisks (**) will appear in this column. [No valid job title] appearing in the Job Class Title indicates that the PCN has an invalid class code or invalid range for the class code effective date of this scenario.

Personal Services Expenditure Detail
Department of Law

Scenario: FY2023 Governor (18673)
Component: Third Judicial District: Outside Anchorage (2279)
RDU: Criminal Division (33)

PCN	Job Class Title	Time Status	Retire Code	Barg Unit	Location	Salary Sched	Range / Step	Comp Months	Split / Count	Annual Salaries	COLA	Premium Pay	Annual Benefits	Total Costs	UGF Amount
03-1307	Attorney 3	FT	A	XE	Kenai	N00	22F / J	12.0		95,727	0	0	55,876	151,603	151,603
03-1316	Law Office Assistant 1	FT	A	GP	Kodiak	211	11E / F	12.0		47,847	0	0	36,595	84,442	84,442
03-1325	Victim/Witness Paralegal 2	FT	A	GP	Dillingham	237	16B / C	12.0		75,504	0	0	46,891	122,395	122,395
03-1338	Victim/Witness Paralegal 2	FT	A	GP	Kenai	200	16B / C	12.0		55,189	0	0	39,328	94,517	94,517
03-1347	Attorney 3	FT	A	XE	Kenai	N00	22D	12.0		86,931	0	0	52,602	139,533	139,533
03-1353	Law Office Assistant 1	FT	A	GP	Palmer	100	11D / E	12.0		42,146	0	0	34,472	76,618	76,618
03-1358	Victim/Witness Paralegal 1	FT	A	GP	Palmer	100	14A / B	12.0		46,776	0	0	36,196	82,972	82,972
03-1365	Attorney 5	FT	A	XE	Palmer	N00	25D / E	12.0		108,220	0	0	60,528	168,748	168,748
03-1366	Attorney 5	FT	A	XE	Kenai	N00	25D / E	12.0		108,220	0	0	60,528	168,748	168,748
03-6526	Law Office Assistant 1	FT	A	GP	Palmer	200	11B / C	12.0		39,111	0	0	33,342	72,453	65,208

Total													Total Salary Costs:	3,812,563	
Positions													Total COLA:	1,450	
Full Time Positions:													Total Premium Pay:	0	
Part Time Positions:													Total Benefits:	2,358,055	
Non Permanent Positions:															
Positions in Component:													Total Pre-Vacancy:	6,172,068	
	48	0	0											Minus Vacancy Adjustment of 4.58%:	(282,668)
	0	0	0											Total Post-Vacancy:	5,889,400
	0	0	0											Plus Lump Sum Premium Pay:	0
	48	0	0											Personal Services Line 100:	5,889,400
Total Component Months:	576.0														

PCN Funding Sources:	Pre-Vacancy	Post-Vacancy	Percent
1004 General Fund Receipts	6,035,281	5,758,877	97.78%
1007 Interagency Receipts	136,787	130,523	2.22%
Total PCN Funding:	6,172,068	5,889,400	100.00%

Note: If a position is split, an asterisk (*) will appear in the Split/Count column. If the split position is also counted in the component, two asterisks (**) will appear in this column. [No valid job title] appearing in the Job Class Title indicates that the PCN has an invalid class code or invalid range for the class code effective date of this scenario.

CRIMINAL DIVISION

Third Judicial District: Outside Anchorage 1 of 2

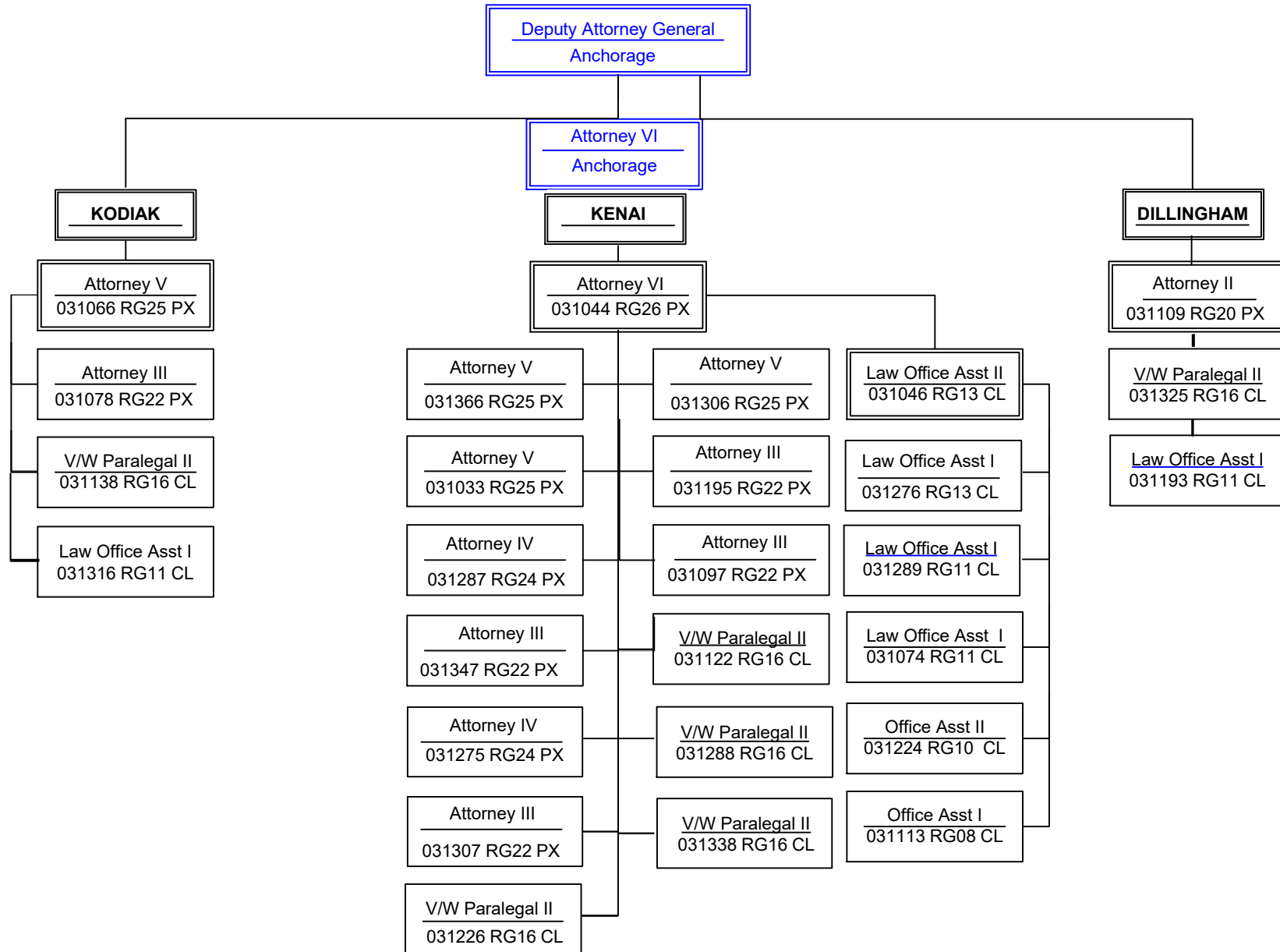

CRIMINAL DIVISION

Third Judicial District: Outside Anchorage 2 of 2

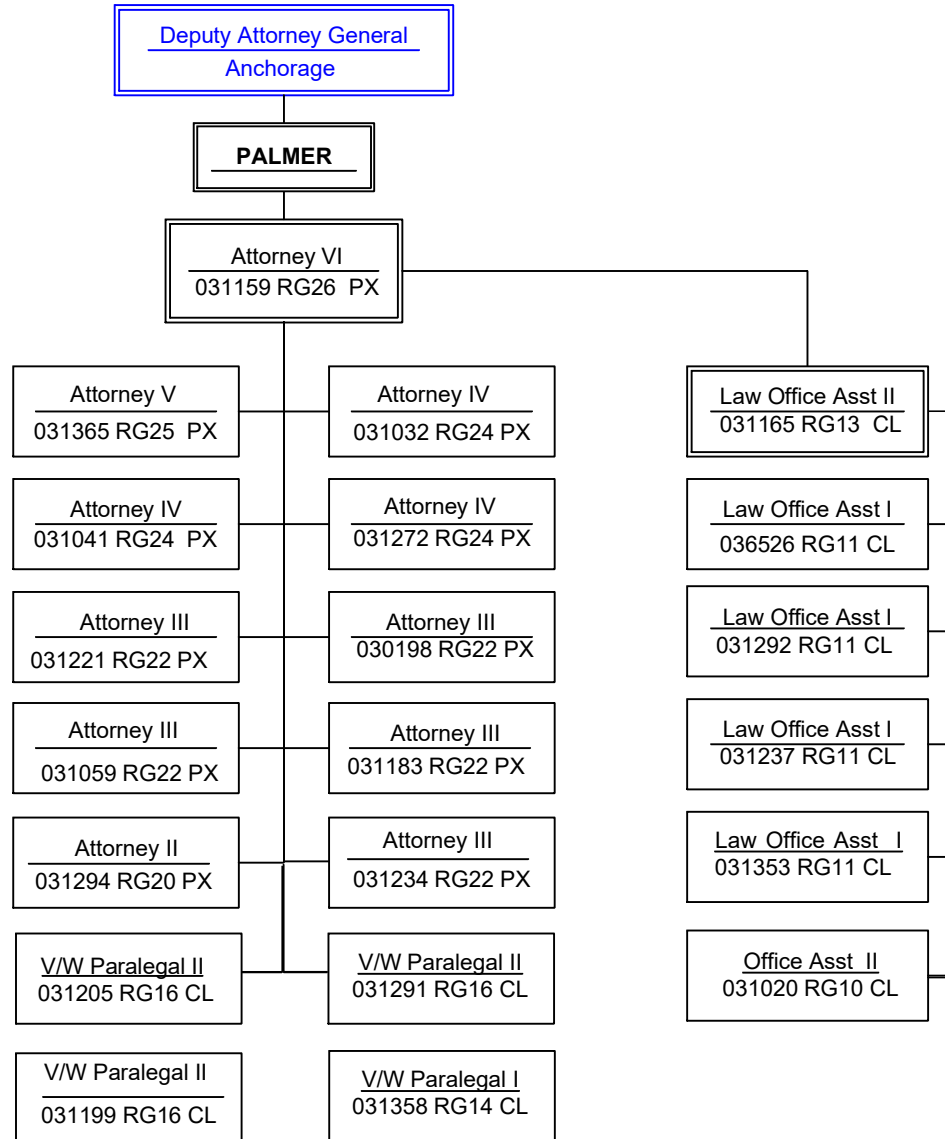

State of Alaska FY2023 Governor's Operating Budget

Department of Law Fourth Judicial District Component Budget Summary

Component: Fourth Judicial District

Contribution to Department's Mission

This component contributes to the department's mission by prosecuting and convicting criminal offenders within the Fourth Judicial District (Central Alaska and the Yukon-Kuskokwim area).

Core Services

- Prosecutes violations of state criminal law by both adults and juveniles in the Fourth Judicial District.
- Provides day-to-day advice to state and local law enforcement agencies conducting criminal investigations and serves as legal advisor to grand juries.
- Handles probation revocation actions, all sentence and sufficiency of evidence appeals and most post-conviction relief proceedings.
- Participate in specialized therapeutic court programs such as wellness courts.
- Provides victim-witness assistance services such as: information on court procedures required by statute and the Alaska Constitution; applying for restitution; arrangement of travel and payment for expenses and court-mandated witness fees; assistance with domestic violence orders and violent crimes compensation procedures; and preparation of victims and witnesses to testify in court.

Major Component Accomplishments in 2021

See Accomplishments at RDU level.

Key Component Challenges

See Key Challenges at RDU level.

Significant Changes in Results to be Delivered in FY2023

See Changes in Results at RDU level.

Statutory and Regulatory Authority

AS 44.23.020

Contact Information

Contact: John Skidmore, Deputy Attorney General
Phone: (907) 269-5100
E-mail: john.skidmore@alaska.gov

Fourth Judicial District Personal Services Information				
Authorized Positions			Personal Services Costs	
	FY2022 Management Plan	FY2023 Governor		
Full-time	50	50	Annual Salaries	4,445,438
Part-time	0	0	COLA	2,756
Nonpermanent	0	0	Premium Pay	0
			Annual Benefits	2,631,056
			<i>Less 5.34% Vacancy Factor</i>	<i>(378,050)</i>
			Lump Sum Premium Pay	0
Totals	50	50	Total Personal Services	6,701,200

Position Classification Summary					
Job Class Title	Anchorage	Fairbanks	Juneau	Others	Total
Attorney 2	0	0	0	3	3
Attorney 3	0	7	0	2	9
Attorney 4	0	6	0	2	8
Attorney 5	0	2	0	1	3
Attorney 6	0	1	0	1	2
Law Office Assistant 1	0	6	0	3	9
Law Office Assistant 2	0	2	0	1	3
Law Office Manager 1	0	1	0	0	1
Office Assistant 1	0	2	0	0	2
Victim/Witness Paralegal 1	0	0	0	1	1
Victim/Witness Paralegal 2	0	6	0	3	9
Totals	0	33	0	17	50

Component Detail All Funds
Department of Law

Component: Fourth Judicial District (2201)
RDU: Criminal Division (33)

Non-Formula Component

	FY2021 Actuals	FY2022 Conference Committee	FY2022 Authorized	FY2022 Management Plan	FY2023 Governor	FY2022 Management Plan vs FY2023 Governor	
71000 Personal Services	5,502.6	6,721.1	6,721.1	6,721.1	6,701.2	-19.9	-0.3%
72000 Travel	55.0	228.2	228.2	228.2	228.2	0.0	0.0%
73000 Services	852.6	252.4	252.4	252.4	252.4	0.0	0.0%
74000 Commodities	54.8	75.3	75.3	75.3	75.3	0.0	0.0%
75000 Capital Outlay	0.0	0.0	0.0	0.0	0.0	0.0	0.0%
77000 Grants, Benefits	0.0	0.0	0.0	0.0	0.0	0.0	0.0%
78000 Miscellaneous	0.0	0.0	0.0	0.0	0.0	0.0	0.0%
Totals	6,465.0	7,277.0	7,277.0	7,277.0	7,257.1	-19.9	-0.3%
Fund Sources:							
1004 Gen Fund (UGF)	6,112.1	6,807.0	6,807.0	6,807.0	6,819.3	12.3	0.2%
1005 GF/Prgm (DGF)	4.9	7.0	7.0	7.0	7.0	0.0	0.0%
1007 I/A Rcpts (Other)	348.0	441.3	441.3	441.3	430.8	-10.5	-2.4%
1108 Stat Desig (Other)	0.0	21.7	21.7	21.7	0.0	-21.7	-100.0%
Unrestricted General (UGF)	6,112.1	6,807.0	6,807.0	6,807.0	6,819.3	12.3	0.2%
Designated General (DGF)	4.9	7.0	7.0	7.0	7.0	0.0	0.0%
Other Funds	348.0	463.0	463.0	463.0	430.8	-32.2	-7.0%
Federal Funds	0.0	0.0	0.0	0.0	0.0	0.0	0.0%
Positions:							
Permanent Full Time	47	50	50	50	50	0	0.0%
Permanent Part Time	0	0	0	0	0	0	0.0%
Non Permanent	0	0	0	0	0	0	0.0%

Change Record Detail - Multiple Scenarios with Descriptions
Department of Law

Component: Fourth Judicial District (2201)
RDU: Criminal Division (33)

Scenario/Change Record Title	Trans Type	Totals	Personal Services	Travel	Services	Commodities	Capital Outlay	Grants, Benefits	Miscellaneous	Positions		NP
										PFT	PPT	
***** Changes From FY2022 Conference Committee To FY2022 Authorized *****												
FY2022 Conference Committee												
	ConfCom	7,277.0	6,721.1	228.2	252.4	75.3	0.0	0.0	0.0	50	0	0
1004 Gen Fund		6,807.0										
1005 GF/Prgm		7.0										
1007 I/A Rcpts		441.3										
1108 Stat Desig		21.7										
Subtotal		7,277.0	6,721.1	228.2	252.4	75.3	0.0	0.0	0.0	50	0	0
***** Changes From FY2022 Management Plan To FY2023 Governor *****												
FY2023 Salary and Benefit Adjustments												
	SalAdj	1.9	1.9	0.0	0.0	0.0	0.0	0.0	0.0	0	0	0
1004 Gen Fund		1.8										
1007 I/A Rcpts		0.1										
FY2023 SU BU - Supervisory Employees (SS) 1% COLA: \$1.9												
FY2023 Executive Health Insurance, SBS, and Risk Management Rate Changes												
	SalAdj	45.5	45.5	0.0	0.0	0.0	0.0	0.0	0.0	0	0	0
1004 Gen Fund		42.7										
1007 I/A Rcpts		2.8										
FY2023 Change Partially Exempt & Exempt Executive (EE) - Health Insurance from \$1,555 to \$1,685; SBS and Risk Management Rates: \$45.5												
FY2023 Supervisory Employees Health Insurance, SBS, and Risk Management Rate Changes												
	SalAdj	5.0	5.0	0.0	0.0	0.0	0.0	0.0	0.0	0	0	0
1004 Gen Fund		4.8										
1007 I/A Rcpts		0.2										
FY2023 Change Supervisory Employees (SS) - Health Insurance from \$1,555 to \$1,685; SBS and Risk Management Rates: \$5.0												
FY2023 General Government Unit SBS and Risk Management Rate Changes												
	SalAdj	3.4	3.4	0.0	0.0	0.0	0.0	0.0	0.0	0	0	0
1004 Gen Fund		3.2										
1007 I/A Rcpts		0.2										
FY2023 Change General Government Unit (GG, GP, GY, GZ) - SBS, and Risk Management Rates: \$3.4												
FY2023 PERS Actuarial Rate Adjustment to 24.79% Ch9 SLA2021 (SB55)												
	SalAdj	-223.7	-223.7	0.0	0.0	0.0	0.0	0.0	0.0	0	0	0

Change Record Detail - Multiple Scenarios with Descriptions
Department of Law

Component: Fourth Judicial District (2201)
RDU: Criminal Division (33)

Scenario/Change Record Title	Trans Type	Totals	Personal Services	Travel	Services	Commodities	Capital Outlay	Grants, Benefits	Miscellaneous	Positions			
										PFT	PPT	NP	
1004 Gen Fund		-209.9											
1007 I/A Rcpts		-13.8											
Includes: FY2023 Adjustment for PERS ARM Board Approved Rate of 24.79% (from 30.11%): \$-223.7													
Fully Fund Positions Added in FY2022 to Combat Sexual Assault													
	Inc	148.0	148.0	0.0	0.0	0.0	0.0	0.0	0.0	0.0	0	0	0
1004 Gen Fund		148.0											
The Department of Law, Criminal Division added a number of full-time prosecutors and support staff positions in the FY2022 Governor's budget in order to increase the resources available to combat sexual assault and the sexual abuse of minors across Alaska. While accepted, these positions were three-quarter funded by the Legislature in the FY2022 enacted budget. This increment will fully-fund the positions and allow the department to maintain full-time employment of these positions.													
Realign PERS Rate Adjustment by Fund Source Ch9 SLA2021 (SB55)													
	FndChg	0.0	0.0	0.0	0.0	0.0	0.0	0.0	0.0	0.0	0	0	0
1004 Gen Fund		21.7											
1108 Stat Desig		-21.7											
Replace unrealizable SDPR authority assigned in SB55 fiscal note (Ch 9 SLA 2021).													
Totals		7,257.1	6,701.2	228.2	252.4	75.3	0.0	0.0	0.0	0.0	50	0	0

Line Item Detail (1676)
Department of Law
Travel

Component: Fourth Judicial District (2201)

Line Number	Line Name		FY2021 Actuals	FY2022 Management Plan	FY2023 Governor
2000	Travel		55.0	228.2	228.2
Object Class	Servicing Agency	Explanation	FY2021 Actuals	FY2022 Management Plan	FY2023 Governor
2000 Travel Detail Totals			55.0	228.2	228.2
2000	In-State Employee Travel	Travel for attorneys to interview witnesses and attend court proceedings, as well as for necessary training for both attorneys and paraprofessionals. Includes travel for management purposes.	6.4	79.0	79.0
2001	In-State Non-Employee Travel	Travel costs for witnesses to testify in court.	27.2	90.0	90.0
2002	Out of State Employee Travel	Travel costs and expenses for out-of-state travel for conferences, training, etc.	0.0	24.7	24.7
2003	Out of State Non-Employee Travel	Travel costs and expenses for out-of-state witnesses to testify in court.	2.9	16.5	16.5
2005	Moving Costs	Moving costs.	18.5	18.0	18.0

Line Item Detail (1676)
Department of Law
Services

Component: Fourth Judicial District (2201)

Line Number	Line Name		FY2021 Actuals	FY2022 Management Plan	FY2023 Governor
3000	Services		852.6	252.4	252.4
Object Class	Servicing Agency	Explanation	FY2021 Actuals	FY2022 Management Plan	FY2023 Governor
3000 Services Detail Totals			852.6	252.4	252.4
3000	Education Services	Conferences, training and memberships.	16.3	1.0	1.0
3002	Legal and Judicial Services	Depositions, research costs, expert witness and consultant fees.	21.1	2.5	2.5
3003	Information Technology	Training, consulting and software licensing and maintenance. Annual maintenance fee for mission-critical information management systems.	2.9	3.1	3.1
3004	Telecommunications	Local telephone service, long distance charges and cellular phone services paid to third-party telephone utilities.	8.3	2.1	2.1
3006	Delivery Services	Freight, courier, postage, and transportation of trial exhibit materials.	4.7	2.0	2.0
3008	Utilities	Waste management disposal costs not included in lease.	3.2	1.1	1.1
3010	Equipment/Machinery	Office equipment rental - copier and postage meters.	2.2	0.2	0.2
3011	Other Services	Cost transfers and miscellaneous items within the services line (commissions, etc.).	16.0	0.2	0.2
3013	Inter-Agency Data Processing Operations Allocation	Law - Administrative Services (2164) RSA Law, Information services, data processing investments and support.	17.6	2.0	2.0
3017	Inter-Agency Information Technology Non-Telecommunications	Admin - Department-wide RSA Administration, Office of Information Technology computer services.	187.7	74.0	74.0

Line Item Detail (1676)
Department of Law
Services

Component: Fourth Judicial District (2201)

Object Class		Servicing Agency	Explanation	FY2021 Actuals	FY2022 Management Plan	FY2023 Governor
3000 Services Detail Totals				852.6	252.4	252.4
3018	Inter-Agency Information Technology Telecommunications	Admin - Department-wide	RSA Administration, Office of Information Technology telecommunications services.	24.6	7.0	7.0
3022	Inter-Agency Human Resources	Law - Administrative Services (2164)	RSA Law, Human Resources position.	42.5	8.2	8.2
3023	Inter-Agency Building Leases	Admin - Department-wide	Leased office space managed by General Services.	492.0	138.2	138.2
3026	Inter-Agency Insurance	Admin - Department-wide	RSA Administration, Risk Management.	3.1	1.1	1.1
3027	Inter-Agency Financial	Admin - Department-wide	RSA Administration, Finance Chargeback (IRIS).	7.6	7.8	7.8
3028	Inter-Agency Americans with Disabilities Act Compliance	Admin - Department-wide	RSA Administration - Division of Personnel and Labor Relations, Americans with Disabilities Act.	0.4	0.4	0.4
3037	State Equipment Fleet	Trans - Department-wide	State vehicle maintenance and operations.	2.4	1.5	1.5

Line Item Detail (1676)
Department of Law
Commodities

Component: Fourth Judicial District (2201)

Line Number	Line Name		FY2021 Actuals	FY2022 Management Plan	FY2023 Governor
4000	Commodities		54.8	75.3	75.3
Object Class	Servicing Agency	Explanation	FY2021 Actuals	FY2022 Management Plan	FY2023 Governor
4000 Commodities Detail Totals			54.8	75.3	75.3
4000	Business	Reference materials and subscriptions, including statutes, software applications, non-capital desktop refresh, and miscellaneous office supplies.	53.5	72.3	72.3
4002	Household/Institutional	Institutional supplies for cleaning and maintenance.	1.3	3.0	3.0

Revenue Detail (1681)
Department of Law

Component: Fourth Judicial District (2201)

Revenue Type (OMB Fund Code) Revenue Source	Component	Comment	FY2021 Actuals	FY2022 Management Plan	FY2023 Governor
5005 GF/Prgm (1005 GF/Prgm)			4.9	7.0	7.0
5119 Program Receipts Law - Charges for Services		Discovery receipts - receipts from private attorneys.	4.9	7.0	7.0
5007 I/A Rcpts (1007 I/A Rcpts)			348.0	441.3	430.8
5301 Inter-Agency Receipts	Courts - Department-wide	Therapeutic Courts (Wellness Court): Participating attorneys recommend potential participants and review them for eligibility, making case-related decisions - Fairbanks RSA. Program code: CM03651401.	50.0	120.0	120.0
5301 Inter-Agency Receipts	PubSaf - Department-wide	Alcohol Interdiction Grant - Federal funds channeled through the Department of Public Safety for additional prosecution efforts in Alaska to reduce violent crime, accidental deaths and incidence of FAS and FAE by cutting off the easy availability of alcohol through aggressive investigation and prosecution of bootlegging offenses in rural Alaska. Program code: CM03651455.	217.0	206.3	209.6
5301 Inter-Agency Receipts	Courts - Department-wide	Therapeutic Courts (Wellness Court): Participating attorneys recommend potential participants and review them for eligibility, making case-related decisions - Bethel RSA. Program code: CM03651451.	81.0	115.0	101.2
5108 Stat Desig (1108 Stat Desig)			0.0	21.7	0.0
5206 Statutory Designated Program Receipts - Contracts		Uncollectible statutory designated program receipt authority,	0.0	21.7	0.0

Revenue Detail (1681)
Department of Law

Component: Fourth Judicial District (2201)

Revenue Type (OMB Fund Code)	Component	Comment	FY2021 Actuals	FY2022 Management Plan	FY2023 Governor
6004 Gen Fund (1004 Gen Fund)			0.4	0.0	0.0
6046 General Fund - Prior Year Reimbursement Recovery		Prior year recovery	0.4	0.0	0.0

Inter-Agency Services (1682)
Department of Law

Component: Fourth Judicial District (2201)

				FY2021 Actuals	FY2022 Management Plan	FY2023 Governor
Component Totals				777.9	240.2	240.2
With Department of Law				60.1	10.2	10.2
With Department of Administration				715.4	228.5	228.5
With Department of Transportation/Public Facilities				2.4	1.5	1.5
Object Class	Servicing Agency	Explanation		FY2021 Actuals	FY2022 Management Plan	FY2023 Governor
3013	Inter-Agency Data Processing Operations Allocation	Law - Administrative Services (2164)	RSA Law, Information services, data processing investments and support.	17.6	2.0	2.0
3017	Inter-Agency Information Technology Non-Telecommunications	Admin - Department-wide	RSA Administration, Office of Information Technology computer services.	187.7	74.0	74.0
3018	Inter-Agency Information Technology Telecommunications	Admin - Department-wide	RSA Administration, Office of Information Technology telecommunications services.	24.6	7.0	7.0
3022	Inter-Agency Human Resources	Law - Administrative Services (2164)	RSA Law, Human Resources position.	42.5	8.2	8.2
3023	Inter-Agency Building Leases	Admin - Department-wide	Leased office space managed by General Services.	492.0	138.2	138.2
3026	Inter-Agency Insurance	Admin - Department-wide	RSA Administration, Risk Management.	3.1	1.1	1.1
3027	Inter-Agency Financial	Admin - Department-wide	RSA Administration, Finance Chargeback (IRIS).	7.6	7.8	7.8
3028	Inter-Agency Americans with Disabilities Act Compliance	Admin - Department-wide	RSA Administration - Division of Personnel and Labor Relations, Americans with Disabilities Act.	0.4	0.4	0.4
3037	State Equipment Fleet	Trans - Department-wide	State vehicle maintenance and operations.	2.4	1.5	1.5

Personal Services Expenditure Detail
Department of Law

Scenario: FY2023 Governor (18673)
Component: Fourth Judicial District (2201)
RDU: Criminal Division (33)

PCN	Job Class Title	Time Status	Retire Code	Barg Unit	Location	Salary Sched	Range / Step	Comp Months	Split / Count	Annual Salaries	COLA	Premium Pay	Annual Benefits	Total Costs	UGF Amount
03-0194	Attorney 3	FT	A	XE	Fairbanks	N03	22B / C	12.0		84,135	0	0	51,561	135,696	135,696
03-1003	Attorney 6	FT	A	XE	Fairbanks	N03	26M / N	12.0		139,477	0	0	72,165	211,642	211,642
03-1007	Attorney 3	FT	A	XE	Fairbanks	N03	22D / E	12.0		92,188	0	0	54,559	146,747	146,747
03-1015	Law Office Manager 1	FT	A	SS	Fairbanks	203	15C / D	12.0		59,766	820	0	42,632	103,218	103,218
03-1042	Attorney 4	FT	A	XE	Fairbanks	N03	24L / M	12.0		123,788	0	0	66,324	190,112	190,112
03-1043	Attorney 4	FT	A	XE	Bethel	N50	24K	12.0		170,235	0	0	82,173	252,408	252,408
03-1045	Law Office Assistant 2	FT	A	GP	Fairbanks	203	13C / D	12.0		47,564	0	0	36,489	84,053	84,053
03-1051	Law Office Assistant 1	FT	A	GP	Fairbanks	203	11C / D	12.0		41,896	0	0	34,379	76,275	76,275
03-1056	Law Office Assistant 1	FT	A	GP	Bethel	250	11C / D	12.0		60,712	0	0	41,384	102,096	102,096
03-1057	Attorney 5	FT	A	XE	Fairbanks	N03	25F	12.0		117,858	0	0	64,116	181,974	181,974
03-1060	Attorney 4	FT	A	XE	Fairbanks	N03	24F	12.0		109,649	0	0	61,060	170,709	170,709
03-1064	Attorney 4	FT	A	XE	Fairbanks	99	24N / O	12.0		126,428	0	0	67,306	193,734	193,734
03-1065	Attorney 6	FT	A	XE	Bethel	N50	26E / F	12.0		176,774	0	0	84,207	260,981	260,981
03-1068	Law Office Assistant 2	FT	A	SS	Bethel	650	13K / L	12.0		89,616	1,230	0	53,745	144,591	127,240
03-1069	Law Office Assistant 1	FT	A	GP	Fairbanks	203	11C / D	12.0		41,420	0	0	34,202	75,622	75,622
03-1072	Law Office Assistant 1	FT	A	GP	Fairbanks	203	11B / C	12.0		40,814	0	0	33,976	74,790	74,790
03-1081	Attorney 3	FT	A	XE	Fairbanks	N03	22C / D	12.0		88,615	0	0	53,229	141,844	141,844
03-1083	Victim/Witness Paralegal 2	FT	A	GP	Fairbanks	203	16C / D	12.0		59,645	0	0	40,987	100,632	100,632
03-1115	Attorney 2	FT	A	XE	Bethel	N50	20E / F	12.0		117,994	0	0	64,166	182,160	182,160
03-1125	Office Assistant 1	FT	A	GP	Fairbanks	203	8C / D	12.0		35,006	0	0	31,814	66,820	66,820
03-1131	Victim/Witness Paralegal 2	FT	A	GP	Fairbanks	99	16P / Q	12.0		86,179	0	0	50,866	137,045	137,045
03-1151	Attorney 4	FT	A	XE	Fairbanks	N03	24M	12.0		124,605	0	0	66,628	191,233	191,233
03-1153	Office Assistant 1	FT	A	GP	Fairbanks	203	8B / C	12.0		33,742	0	0	31,343	65,085	65,085
03-1158	Attorney 4	FT	A	XE	Bethel	N50	24B / C	12.0		143,406	0	0	73,627	217,033	151,923
03-1189	Attorney 3	FT	A	XE	Fairbanks	N03	22D / E	12.0		90,251	0	0	53,838	144,089	144,089
03-1196	Victim/Witness Paralegal 2	FT	A	GP	Fairbanks	203	16L / M	12.0		75,887	0	0	47,034	122,921	122,921
03-1197	Law Office Assistant 1	FT	A	GP	Fairbanks	203	11D / E	12.0		43,656	0	0	35,034	78,690	78,690
03-1200	Attorney 3	FT	A	XE	Fairbanks	N03	22F	12.0		95,745	0	0	55,883	151,628	151,628
03-1229	Attorney 4	FT	A	XE	Fairbanks	N03	24A / B	12.0		94,226	0	0	55,318	149,544	149,544
03-1238	Attorney 3	FT	A	XE	Bethel	N50	22E / F	12.0		136,113	0	0	70,912	207,025	207,025
03-1239	Attorney 3	FT	A	XE	Fairbanks	N03	22C / D	12.0		88,225	0	0	53,083	141,308	141,308
03-1243	Victim/Witness Paralegal 2	FT	A	GP	Bethel	250	16C / D	12.0		86,503	0	0	50,986	137,489	137,489
03-1252	Victim/Witness Paralegal 2	FT	A	GP	Bethel	250	16F / G	12.0		96,530	0	0	54,719	151,249	30,250
03-1257	Attorney 3	FT	A	XE	Bethel	N50	22F	12.0		139,445	0	0	72,153	211,598	211,598
03-1260	Law Office Assistant 1	FT	A	GP	Bethel	250	11B / C	12.0		58,666	0	0	40,623	99,289	99,289
03-1261	Law Office Assistant 1	FT	A	GP	Fairbanks	203	11C / D	12.0		41,558	0	0	34,253	75,811	68,230
03-1274	Victim/Witness Paralegal 2	FT	A	GP	Fairbanks	203	16B / C	12.0		57,662	0	0	40,249	97,911	97,911
03-1286	Law Office Assistant 2	FT	A	SS	Fairbanks	603	13C / D	12.0		51,440	706	0	39,532	91,678	91,678

Note: If a position is split, an asterisk (*) will appear in the Split/Count column. If the split position is also counted in the component, two asterisks (**) will appear in this column. [No valid job title] appearing in the Job Class Title indicates that the PCN has an invalid class code or invalid range for the class code effective date of this scenario.

Personal Services Expenditure Detail
Department of Law

Scenario: FY2023 Governor (18673)
Component: Fourth Judicial District (2201)
RDU: Criminal Division (33)

PCN	Job Class Title	Time Status	Retire Code	Barg Unit	Location	Salary Sched	Range / Step	Comp Months	Split / Count	Annual Salaries	COLA	Premium Pay	Annual Benefits	Total Costs	UGF Amount
03-1290	Attorney 4	FT	A	XE	Fairbanks	N03	24F / J	12.0		111,581	0	0	61,779	173,360	130,020
03-1300	Attorney 2	FT	A	XE	Bethel	N50	20B / C	12.0		109,974	0	0	61,181	171,155	0
03-1314	Victim/Witness Paralegal 2	FT	A	GP	Bethel	250	16A / B	12.0		79,521	0	0	48,387	127,908	127,908
03-1320	Attorney 2	FT	A	XE	Bethel	N50	20C / D	12.0		111,060	0	0	61,585	172,645	172,645
03-1321	Law Office Assistant 1	FT	A	GP	Bethel	250	11D / E	12.0		62,363	0	0	41,999	104,362	104,362
03-1326	Victim/Witness Paralegal 2	FT	A	GP	Fairbanks	203	16D / E	12.0		61,223	0	0	41,575	102,798	102,798
03-1334	Victim/Witness Paralegal 2	FT	A	GP	Fairbanks	203	16B / C	12.0		56,495	0	0	39,814	96,309	96,309
03-1335	Attorney 3	FT	A	XE	Fairbanks	N03	22C / D	12.0		87,939	0	0	52,977	140,916	140,916
03-1354	Law Office Assistant 1	FT	A	GP	Fairbanks	203	11M	12.0		53,762	0	0	38,797	92,559	92,559
03-1359	Victim/Witness Paralegal 1	FT	A	GP	Bethel	150	14A / B	12.0		69,977	0	0	44,834	114,811	114,811
03-1367	Attorney 5	FT	A	XE	Bethel	N50	25D / E	12.0		162,331	0	0	79,715	242,046	242,046
03-1370	Attorney 5	FT	A	XE	Fairbanks	N03	25D / E	12.0		111,793	0	0	61,858	173,651	173,651

Total Positions				Total Salary Costs:	4,445,438
Full Time Positions:	50	New	0	Total COLA:	2,756
Part Time Positions:	0	Deleted	0	Total Premium Pay:	0
Non Permanent Positions:	0		0	Total Benefits:	2,631,056
Positions in Component:	50		0	Total Pre-Vacancy:	7,079,250
				Minus Vacancy Adjustment of 5.34%:	(378,050)
				Total Post-Vacancy:	6,701,200
				Plus Lump Sum Premium Pay:	0
				Personal Services Line 100:	6,701,200

PCN Funding Sources:	Pre-Vacancy	Post-Vacancy	Percent
1004 General Fund Receipts	6,653,714	6,298,389	93.99%
1007 Interagency Receipts	425,536	402,811	6.01%
Total PCN Funding:	7,079,250	6,701,200	100.00%

Note: If a position is split, an asterisk (*) will appear in the Split/Count column. If the split position is also counted in the component, two asterisks (**) will appear in this column. [No valid job title] appearing in the Job Class Title indicates that the PCN has an invalid class code or invalid range for the class code effective date of this scenario.

CRIMINAL DIVISION

Fourth Judicial District

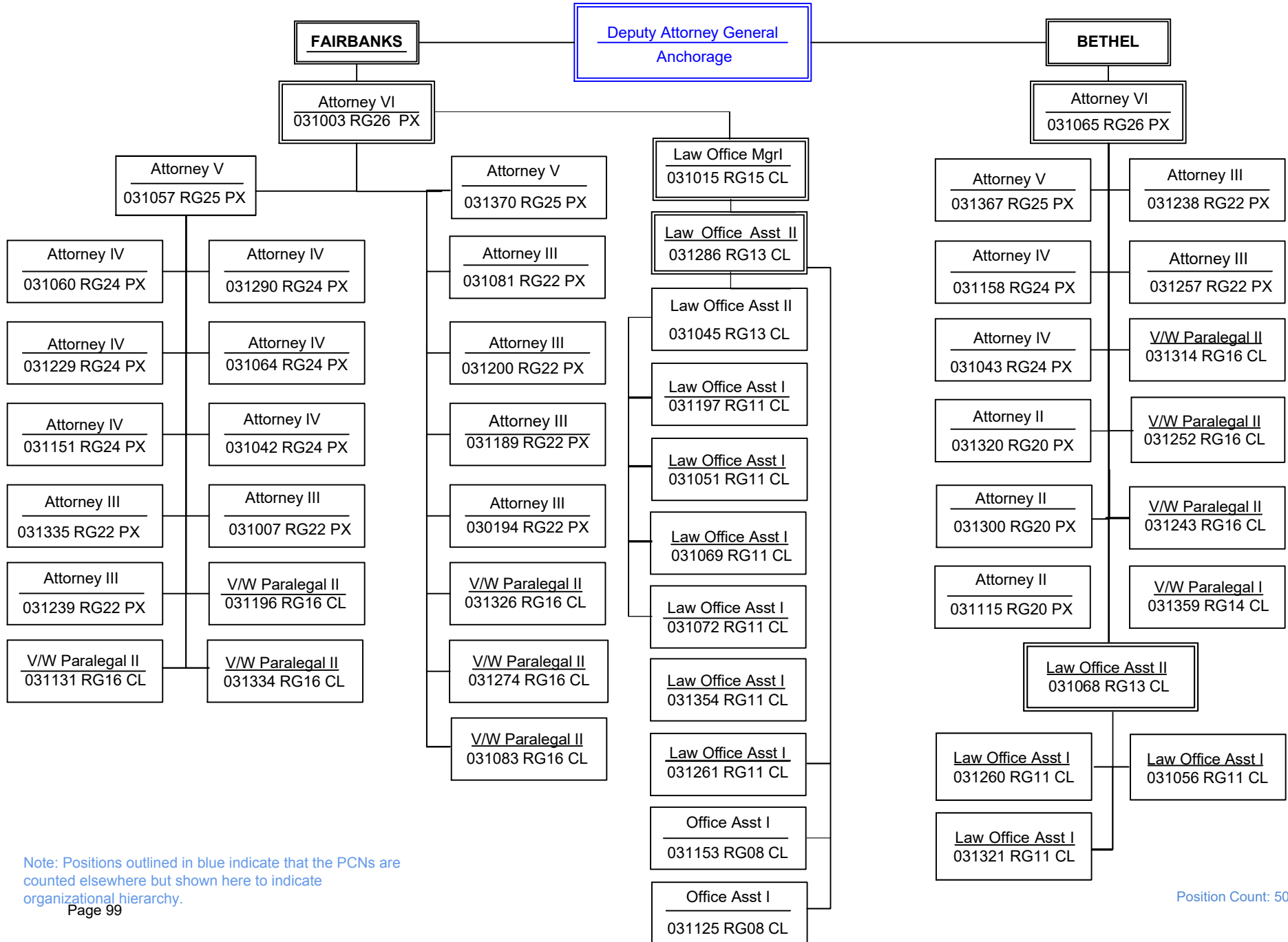

Note: Positions outlined in blue indicate that the PCNs are counted elsewhere but shown here to indicate organizational hierarchy.

State of Alaska FY2023 Governor's Operating Budget

Department of Law Criminal Justice Litigation Component Budget Summary

Component: Criminal Justice Litigation

Contribution to Department's Mission

This component contributes to the department's mission by providing legal services that support the efforts of criminal justice agencies, and by providing policy direction for and direct supervision of the Criminal Division.

Core Services

- Provides general legal advice and services to the Department of Public Safety including representation in civil litigation, and assistance with drafting legislation, regulations, policies, and procedures. Funding is through a reimbursable services agreement with the Department of Public Safety.
- Advises the governor and the legislature on criminal justice legislation.
- Provides overall administration of the Criminal Division and sets policy for all offices in the Criminal Division by monitoring and approving budgetary expenditures, setting uniform prosecution policies, maintaining a case management system, recruiting and direct personnel management.

Major Component Accomplishments in 2021

See Accomplishments at RDU level.

Key Component Challenges

See Key Challenges at RDU level.

Significant Changes in Results to be Delivered in FY2023

See Changes in Results at RDU level.

Statutory and Regulatory Authority

AS 44.23.020

Contact Information

Contact: John Skidmore, Deputy Attorney General
Phone: (907) 269-5100
E-mail: john.skidmore@alaska.gov

Criminal Justice Litigation Personal Services Information				
Authorized Positions			Personal Services Costs	
	<u>FY2022</u> <u>Management</u> <u>Plan</u>	<u>FY2023</u> <u>Governor</u>		
Full-time	15	14	Annual Salaries	1,311,079
Part-time	0	0	COLA	1,384
Nonpermanent	0	0	Premium Pay	0
			Annual Benefits	762,756
			<i>Less 2.95% Vacancy Factor</i>	(61,119)
			Lump Sum Premium Pay	0
Totals	15	14	Total Personal Services	2,014,100

Position Classification Summary					
Job Class Title	Anchorage	Fairbanks	Juneau	Others	Total
Administrative Assistant 2	1	0	1	0	2
Administrative Officer 1	0	0	1	0	1
Admn OPS Mgr 1	1	0	0	0	1
Associate Attorney 2	2	0	0	0	2
Attorney 2	1	0	0	0	1
Attorney 5	2	0	1	0	3
Deputy Attorney General	1	0	0	0	1
Division Director - Px	1	0	0	0	1
Law Office Assistant 1	1	0	0	0	1
Research Analyst 3	1	0	0	0	1
Totals	11	0	3	0	14

Component Detail All Funds
Department of Law

Component: Criminal Justice Litigation (2202)
RDU: Criminal Division (33)

Non-Formula Component

	FY2021 Actuals	FY2022 Conference Committee	FY2022 Authorized	FY2022 Management Plan	FY2023 Governor	FY2022 Management Plan vs FY2023 Governor	
71000 Personal Services	1,726.6	2,296.8	2,296.8	2,145.0	2,014.1	-130.9	-6.1%
72000 Travel	3.6	80.6	80.6	80.6	80.6	0.0	0.0%
73000 Services	373.6	702.5	702.5	702.5	677.5	-25.0	-3.6%
74000 Commodities	44.7	60.3	60.3	60.3	60.3	0.0	0.0%
75000 Capital Outlay	0.0	5.0	5.0	5.0	5.0	0.0	0.0%
77000 Grants, Benefits	0.0	0.0	0.0	0.0	0.0	0.0	0.0%
78000 Miscellaneous	0.0	0.0	0.0	0.0	0.0	0.0	0.0%
Totals	2,148.5	3,145.2	3,145.2	2,993.4	2,837.5	-155.9	-5.2%
Fund Sources:							
1004 Gen Fund (UGF)	1,757.1	2,461.0	2,461.0	2,309.2	2,253.4	-55.8	-2.4%
1005 GF/Prgm (DGF)	0.0	1.0	1.0	1.0	1.0	0.0	0.0%
1007 I/A Rcpts (Other)	391.4	683.2	683.2	683.2	583.1	-100.1	-14.7%
Unrestricted General (UGF)	1,757.1	2,461.0	2,461.0	2,309.2	2,253.4	-55.8	-2.4%
Designated General (DGF)	0.0	1.0	1.0	1.0	1.0	0.0	0.0%
Other Funds	391.4	683.2	683.2	683.2	583.1	-100.1	-14.7%
Federal Funds	0.0	0.0	0.0	0.0	0.0	0.0	0.0%
Positions:							
Permanent Full Time	15	15	15	15	14	-1	-6.7%
Permanent Part Time	0	0	0	0	0	0	0.0%
Non Permanent	0	0	0	0	0	0	0.0%

Change Record Detail - Multiple Scenarios with Descriptions
Department of Law

Component: Criminal Justice Litigation (2202)
RDU: Criminal Division (33)

Scenario/Change Record Title	Trans Type	Totals	Personal Services	Travel	Services	Commodities	Capital Outlay	Grants, Benefits	Miscellaneous	Positions		NP
										PFT	PPT	
***** Changes From FY2022 Conference Committee To FY2022 Authorized *****												
FY2022 Conference Committee												
	ConfCom	3,145.2	2,296.8	80.6	702.5	60.3	5.0	0.0	0.0	15	0	0
1004 Gen Fund		2,461.0										
1005 GF/Prgm		1.0										
1007 I/A Rcpts		683.2										
Subtotal		3,145.2	2,296.8	80.6	702.5	60.3	5.0	0.0	0.0	15	0	0
***** Changes From FY2022 Authorized To FY2022 Management Plan *****												
Transfer Attorney 5 (03-1280) from Criminal Appeals/Special Litigation for Required Legal Expertise												
	Trin	0.0	0.0	0.0	0.0	0.0	0.0	0.0	0.0	1	0	0
Transfer one full-time Attorney 5 position (03-1280), range 25, located in Anchorage, from Criminal Appeals/Special Litigation to the Criminal Justice Litigation component, Anchorage office to keep pace with the required level of legal expertise needed within the office. The remaining staff in Criminal Appeals/Special Litigation are sufficient to accommodate anticipated workload.												
Transfer Attorney 6 (03-1058) to Criminal Appeals/Special Litigation for Required Legal Expertise												
	Trout	-151.8	-151.8	0.0	0.0	0.0	0.0	0.0	0.0	-1	0	0
1004 Gen Fund		-151.8										
Transfer one full-time Attorney 6 position (03-1058), range 26, located in Anchorage, to Criminal Appeals/Special Litigation from Criminal Justice Litigation to keep pace with the required level of legal expertise needed within the office. The remaining staff in Criminal Justice Litigation are sufficient to accommodate anticipated workload.												
Subtotal		2,993.4	2,145.0	80.6	702.5	60.3	5.0	0.0	0.0	15	0	0
***** Changes From FY2022 Management Plan To FY2023 Governor *****												
FY2023 Salary and Benefit Adjustments												
	SalAdj	1.7	1.7	0.0	0.0	0.0	0.0	0.0	0.0	0	0	0
1004 Gen Fund		1.7										
FY2023 SU BU - Supervisory Employees (SS) 1% COLA: \$1.7												
FY2023 Executive Health Insurance, SBS, and Risk Management Rate Changes												
	SalAdj	15.3	15.3	0.0	0.0	0.0	0.0	0.0	0.0	0	0	0
1004 Gen Fund		11.4										
1007 I/A Rcpts		3.9										
FY2023 Change Partially Exempt & Exempt Executive (EE) - Health Insurance from \$1,555 to \$1,685; SBS and Risk Management Rates: \$15.3												

Change Record Detail - Multiple Scenarios with Descriptions
Department of Law

Component: Criminal Justice Litigation (2202)
RDU: Criminal Division (33)

Scenario/Change Record Title	Trans Type	Totals	Personal Services	Travel	Services	Commodities	Capital Outlay	Grants, Benefits	Miscellaneous	Positions		NP
										PFT	PPT	
FY2023 Supervisory Employees Health Insurance, SBS, and Risk Management Rate Changes												
1004 Gen Fund	SalAdj	1.8	1.8	0.0	0.0	0.0	0.0	0.0	0.0	0	0	0
FY2023 Change Supervisory Employees (SS) - Health Insurance from \$1,555 to \$1,685; SBS and Risk Management Rates: \$1.8												
FY2023 General Government Unit SBS and Risk Management Rate Changes												
1004 Gen Fund	SalAdj	0.7	0.9	0.0	0.0	0.0	0.0	0.0	0.0	0	0	0
1007 I/A Rcpts		0.2										
FY2023 Change General Government Unit (GG, GP, GY, GZ) - SBS, and Risk Management Rates: \$0.9												
FY2023 PERS Actuarial Rate Adjustment to 24.79% Ch9 SLA2021 (SB55)												
1004 Gen Fund	SalAdj	-56.4	-71.4	0.0	0.0	0.0	0.0	0.0	0.0	0	0	0
1007 I/A Rcpts		-15.0										
Includes: FY2023 Adjustment for PERS ARM Board Approved Rate of 24.79% (from 30.11%): \$-71.4												
Delete Program Coordinator 1 (03-1340) in Criminal Justice Litigation												
1007 I/A Rcpts	Dec	-104.2	-104.2	0.0	0.0	0.0	0.0	0.0	0.0	-1	0	0
Delete Program Coordinator 1 (03-1340) in the Criminal Justice Litigation's Anchorage office in order to better align the number of positions with actual funding available for personal services. The inter-agency receipts supporting this position via a reimbursable services agreement are no longer available.												
Realign PERS Rate Adjustment by Fund Source Ch9 SLA2021 (SB55)												
1004 Gen Fund	FndChg	-15.0	0.0	0.0	0.0	0.0	0.0	0.0	0.0	0	0	0
1007 I/A Rcpts		15.0										
Fund source adjustments were made to this component in the SB55 fiscal note (Ch 9 SLA 2021) to accommodate the application of the actuarial PERS rate in FY2022. This transaction realigns fund sources to reduce the UGF subsidy assigned in the fiscal note.												
Transfer Authority from Services for Anticipated Personal Service Expenditures												
	LIT	0.0	25.0	0.0	-25.0	0.0	0.0	0.0	0.0	0	0	0
Transfer authority from the services line to the personal services line for anticipated personal services costs. The remaining services authority is anticipated to be sufficient to cover operating expenditures.												

Change Record Detail - Multiple Scenarios with Descriptions
Department of Law

Component: Criminal Justice Litigation (2202)
RDU: Criminal Division (33)

Scenario/Change Record Title	Trans Type	Totals	Personal Services	Travel	Services	Commodities	Capital Outlay	Grants, Benefits	Miscellaneous	Positions		
										PFT	PPT	NP
	Totals	2,837.5	2,014.1	80.6	677.5	60.3	5.0	0.0	0.0	14	0	0

Line Item Detail (1676)
Department of Law
Travel

Component: Criminal Justice Litigation (2202)

Line Number	Line Name		FY2021 Actuals	FY2022 Management Plan	FY2023 Governor
2000	Travel		3.6	80.6	80.6
Object Class	Servicing Agency	Explanation	FY2021 Actuals	FY2022 Management Plan	FY2023 Governor
2000 Travel Detail Totals			3.6	80.6	80.6
2000	In-State Employee Travel	Travel for attorneys to interview witnesses and attend court proceedings, as well as for necessary training for both attorneys and paraprofessionals. Includes travel for management purposes.	3.6	74.6	74.6
2001	In-State Non-Employee Travel	Travel costs for witnesses to testify in court.	0.0	2.0	2.0
2002	Out of State Employee Travel	Travel costs and expenses for out-of-state travel for conferences, training, etc.	0.0	4.0	4.0

Line Item Detail (1676)
Department of Law
Services

Component: Criminal Justice Litigation (2202)

Line Number	Line Name		FY2021 Actuals	FY2022 Management Plan	FY2023 Governor
3000	Services		373.6	702.5	677.5
Object Class	Servicing Agency	Explanation	FY2021 Actuals	FY2022 Management Plan	FY2023 Governor
3000 Services Detail Totals			373.6	702.5	677.5
3000	Education Services	Conferences, training and memberships.	14.6	28.0	28.0
3002	Legal and Judicial Services	Depositions, research costs, expert witness and consultant fees.	35.8	80.8	80.8
3003	Information Technology	Training, consulting and software licensing and maintenance. Annual maintenance fee for mission-critical information management systems.	10.7	14.0	14.0
3004	Telecommunications	Local telephone service, long distance charges and cellular phone services paid to third-party telephone utilities.	8.9	10.0	10.0
3005	Health Services	Costs associated with health and safety services.	0.4	1.0	1.0
3006	Delivery Services	Freight, courier, postage, and transportation of trial exhibit materials.	1.9	10.4	10.4
3007	Advertising and Promotions	Publication of legal notices.	1.1	10.4	10.4
3009	Structure/Infrastructure/Land	Rentals/leases - records and evidence storage.	42.2	91.2	91.2
3011	Other Services	Cost transfers and miscellaneous items within the services line (commissions, etc.).	1.6	90.0	65.0
3013	Inter-Agency Data Processing Operations Allocation	Law - Administrative Services (2164) RSA Law, Information services, data processing investments and support.	5.6	10.0	10.0
3017	Inter-Agency Information Technology	Admin - Department-wide RSA Administration, Office of	63.9	80.0	80.0

Line Item Detail (1676)
Department of Law
Services

Component: Criminal Justice Litigation (2202)

Object Class	Servicing Agency	Explanation	FY2021 Actuals	FY2022 Management Plan	FY2023 Governor
3000 Services Detail Totals			373.6	702.5	677.5
Non-Telecommunications		Information Technology computer services.			
3018 Inter-Agency Information Technology Telecommunications	Admin - Department-wide	RSA Administration, Office of Information Technology telecommunications services.	8.3	47.1	47.1
3021 Inter-Agency Mail	Admin - Department-wide	RSA Administration, Central Mail.	0.8	2.0	2.0
3022 Inter-Agency Human Resources	Law - Administrative Services (2164)	RSA Law, Human Resources position.	14.6	34.0	34.0
3023 Inter-Agency Building Leases	Admin - Department-wide	Leased office space managed by General Services.	133.1	140.0	140.0
3026 Inter-Agency Insurance	Admin - Department-wide	RSA Administration, Risk Management.	1.1	2.0	2.0
3027 Inter-Agency Financial	Admin - Department-wide	RSA Administration, Finance Chargeback (IRIS).	2.5	9.4	9.4
3028 Inter-Agency Americans with Disabilities Act Compliance	Admin - Department-wide	RSA Administration - Division of Personnel and Labor Relations, Americans with Disabilities Act.	0.1	0.4	0.4
3038 Inter-Agency Management/Consulting	Law - Administrative Services (2164)	RSA Law, Information services, project and management support.	26.4	41.8	41.8

Line Item Detail (1676)
Department of Law
Commodities

Component: Criminal Justice Litigation (2202)

Line Number	Line Name		FY2021 Actuals	FY2022 Management Plan	FY2023 Governor
4000	Commodities		44.7	60.3	60.3
Object Class	Servicing Agency	Explanation	FY2021 Actuals	FY2022 Management Plan	FY2023 Governor
4000 Commodities Detail Totals			44.7	60.3	60.3
4000	Business	Reference materials and subscriptions, including statutes, software applications, non-capital desktop refresh, and miscellaneous office supplies.	40.0	50.0	50.0
4002	Household/Institutional	Institutional supplies for cleaning and maintenance.	2.0	4.0	4.0
4004	Safety	Safety and security purchases.	2.7	6.3	6.3

Line Item Detail (1676)
Department of Law
Capital Outlay

Component: Criminal Justice Litigation (2202)

Line Number	Line Name		FY2021 Actuals	FY2022 Management Plan	FY2023 Governor
5000	Capital Outlay		0.0	5.0	5.0
Object Class	Servicing Agency	Explanation	FY2021 Actuals	FY2022 Management Plan	FY2023 Governor
5000 Capital Outlay Detail Totals			0.0	5.0	5.0
5004	Equipment	Equipment purchases.	0.0	5.0	5.0

Revenue Detail (1681)
Department of Law

Component: Criminal Justice Litigation (2202)

Revenue Type (OMB Fund Code) Revenue Source	Component	Comment	FY2021 Actuals	FY2022 Management Plan	FY2023 Governor
5005 GF/Prgm (1005 GF/Prgm)			0.0	1.0	1.0
5119 Program Receipts Law - Charges for Services		Discovery services - receipts from private attorneys.	0.0	1.0	1.0
5007 I/A Rcpts (1007 I/A Rcpts)			391.4	683.2	687.3
5301 Inter-Agency Receipts	PubSaf - Department-wide	RSA Public Safety, STOP VAWA Project - implementation of the prosecution components of the Federal Violence Against Women Act. Program code: CM03651661.	141.4	250.0	225.0
5301 Inter-Agency Receipts	PubSaf - Department-wide	RSA Public Safety, Comprehensive Opioid Abuse Program. Program code: CM0365COAP.	0.0	183.2	212.3
5301 Inter-Agency Receipts	PubSaf - Department-wide	RSA Public Safety - legal services for the Department of Public Safety. Program code: CM03651675.	250.0	250.0	250.0

Inter-Agency Services (1682)
Department of Law

Component: Criminal Justice Litigation (2202)

				FY2021 Actuals	FY2022 Management Plan	FY2023 Governor
Component Totals				256.4	366.7	366.7
With Department of Law				46.6	85.8	85.8
With Department of Administration				209.8	280.9	280.9
Object Class	Servicing Agency	Explanation	FY2021 Actuals	FY2022 Management Plan	FY2023 Governor	
3013	Inter-Agency Data Processing Operations Allocation	Law - Administrative Services (2164)	RSA Law, Information services, data processing investments and support.	5.6	10.0	10.0
3017	Inter-Agency Information Technology Non-Telecommunications	Admin - Department-wide	RSA Administration, Office of Information Technology computer services.	63.9	80.0	80.0
3018	Inter-Agency Information Technology Telecommunications	Admin - Department-wide	RSA Administration, Office of Information Technology telecommunications services.	8.3	47.1	47.1
3021	Inter-Agency Mail	Admin - Department-wide	RSA Administration, Central Mail.	0.8	2.0	2.0
3022	Inter-Agency Human Resources	Law - Administrative Services (2164)	RSA Law, Human Resources position.	14.6	34.0	34.0
3023	Inter-Agency Building Leases	Admin - Department-wide	Leased office space managed by General Services.	133.1	140.0	140.0
3026	Inter-Agency Insurance	Admin - Department-wide	RSA Administration, Risk Management.	1.1	2.0	2.0
3027	Inter-Agency Financial	Admin - Department-wide	RSA Administration, Finance Chargeback (IRIS).	2.5	9.4	9.4
3028	Inter-Agency Americans with Disabilities Act Compliance	Admin - Department-wide	RSA Administration - Division of Personnel and Labor Relations, Americans with Disabilities Act.	0.1	0.4	0.4
3038	Inter-Agency Management/Consulting	Law - Administrative Services (2164)	RSA Law, Information services, project and management support.	26.4	41.8	41.8

Personal Services Expenditure Detail
Department of Law

Scenario: FY2023 Governor (18673)
Component: Criminal Justice Litigation (2202)
RDU: Criminal Division (33)

PCN	Job Class Title	Time Status	Retire Code	Barg Unit	Location	Salary Sched	Range / Step	Comp Months	Split / Count	Annual Salaries	COLA	Premium Pay	Annual Benefits	Total Costs	UGF Amount
03-0131	Law Office Assistant 1	FT	A	GP	Anchorage	200	11F / G	12.0		45,013	0	0	35,540	80,553	80,553
03-0137	Associate Attorney 2	FT	A	XE	Anchorage	N00	19F / J	12.0		77,218	0	0	48,986	126,204	126,204
03-1004	Attorney 5	FT	A	XE	Juneau	N05	25O	12.0		145,568	0	0	74,432	220,000	220,000
03-1006	Attorney 2	FT	A	XE	Anchorage	N00	20C / D	12.0		75,177	0	0	48,226	123,403	123,403
03-1076	Division Director - Px	FT	A	XE	Anchorage	N00	27K / L	12.0		132,677	0	0	69,633	202,310	202,310
03-1160	Admn OPS Mgr 1	FT	A	SS	Anchorage	200	22E / F	12.0		100,859	1,384	0	57,931	160,174	160,174
03-1167	Deputy Attorney General	FT	A	XE	Anchorage	N00	28Q / R	12.0		165,033	0	0	80,555	245,588	245,588
03-1185	Associate Attorney 2	FT	A	XE	Anchorage	N00	19E / F	12.0		75,379	0	0	48,301	123,680	0
03-1187	Administrative Assistant 2	FT	A	GP	Anchorage	200	14A / B	12.0		46,573	0	0	36,120	82,693	82,693
03-1198	Administrative Assistant 2	FT	A	GP	Juneau	205	14A / B	12.0		49,043	0	0	37,040	86,083	86,083
03-1216	Administrative Officer 1	FT	A	GP	Juneau	205	17B / C	12.0		62,961	0	0	42,222	105,183	105,183
03-1280	Attorney 5	FT	A	XE	Anchorage	N00	25F / J	12.0		117,205	0	0	63,873	181,078	181,078
03-1305	Attorney 5	FT	A	XE	Anchorage	99	25P / R	12.0		153,570	0	0	76,990	230,560	0
03-1340	Program Coordinator 1	FT	A	GP	Anchorage	100	18A / B	12.0		0	0	0	0	0	0
03-1343	Research Analyst 3	FT	A	GP	Anchorage	200	18C / D	12.0		64,803	0	0	42,907	107,710	107,710

	Total Positions	New	Deleted		Total Salary Costs:	1,311,079
					Total COLA:	1,384
Full Time Positions:	14	0	1		Total Premium Pay:	0
Part Time Positions:	0	0	0		Total Benefits:	762,756
Non Permanent Positions:	0	0	0			
Positions in Component:	14	0	1		Total Pre-Vacancy:	2,075,219
					Minus Vacancy Adjustment of 2.95%:	(61,119)
					Total Post-Vacancy:	2,014,100
Total Component Months:	168.0				Plus Lump Sum Premium Pay:	0
					Personal Services Line 100:	2,014,100

PCN Funding Sources:	Pre-Vacancy	Post-Vacancy	Percent
1004 General Fund Receipts	1,720,979	1,670,293	82.93%
1007 Interagency Receipts	354,240	343,807	17.07%
Total PCN Funding:	2,075,219	2,014,100	100.00%

Note: If a position is split, an asterisk (*) will appear in the Split/Count column. If the split position is also counted in the component, two asterisks (**) will appear in this column. [No valid job title] appearing in the Job Class Title indicates that the PCN has an invalid class code or invalid range for the class code effective date of this scenario.

CRIMINAL DIVISION

Criminal Justice Litigation

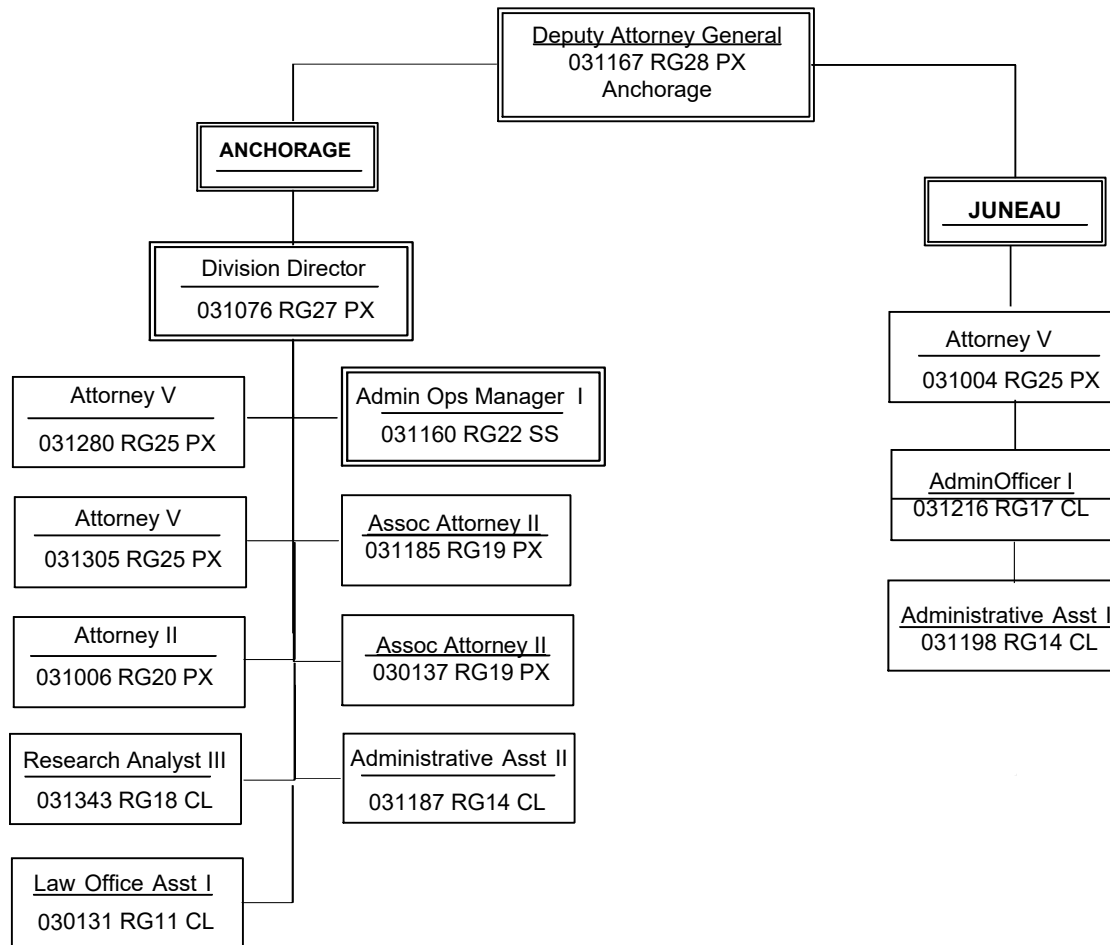

State of Alaska
FY2023 Governor's Operating Budget

Department of Law
Criminal Appeals/Special Litigation
Component Budget Summary

Component: Criminal Appeals/Special Litigation**Contribution to Department's Mission**

This component contributes to the department's mission by prosecuting and convicting criminal offenders in specialized areas of the law, and by upholding convictions on appeal.

Core Services

- Office of Criminal Appeals: Represents the state in most felony appellate proceedings, in misdemeanor proceedings that involve issues of statewide importance, and in other criminal appeals where necessary to assist rural or understaffed district attorney's offices.
- Office of Criminal Appeals: Represents the state in all criminal matters filed in the state supreme court, to include petitions for review arising from criminal appellate matters decided by the court of appeals. The office's representation during the appellate process safeguards these convictions and minimizes the risk that trials will have to be repeated.
- Office of Criminal Appeals: Provides assistance to district attorney's offices in filing responses to interlocutory appeals that arise prior to or during trial. Provides assistance to district attorney's offices when responding to issues of first impression arising in the trial courts. Provides advice and assistance as needed during criminal trial litigation in order to ensure that the convictions obtained will withstand later appellate review.
- Office of Criminal Appeals: Represents the state in appeals relating to state post-conviction proceedings in the state appellate courts. Handles federal habeas corpus claims in the federal district and appeals courts. Representation of the state in these proceedings is constitutionally required. These appellate and post-conviction functions are fundamental aspects of the criminal justice system.
- Office of Special Prosecutions: Supports rural prosecutor offices by handling selected violent crimes and sexual crimes in rural Alaska. Prosecutes cold cases for murder and sexual assault from across the state.
- Office of Special Prosecutions: Handles cases involving criminal charges against police officers, or cases in which the local district attorney's office has some kind of conflict with handling the case.
- Office of Special Prosecutions: Prosecutes economic and other complex crimes. In addition to filing criminal charges and conducting criminal trials, this office also gives day-to-day advice to special "white collar" investigation units. These prosecution services protect private investors, small businesses and government agencies that are the victims of fraud or other wrongdoing.
- Office of Special Prosecutions: Prosecutes bootlegging and alcohol interdiction cases in Anchorage, Bethel, Nome and Kotzebue, and provides legal advice during investigations. Funding is through a reimbursable services agreement with the Department of Public Safety.
- Office of Special Prosecutions: Prosecutes selected drug importation and trafficking cases are handled by the regional district attorney's office.
- Office of Special Prosecutions: Through a federal grant and matching state general funds, prosecutes medical providers who defraud the Medicaid system. The section can institute criminal prosecution for fraud or civil actions for overpayments. In addition, the unit is responsible for investigating and prosecuting abuse of patients in Medicaid-funded facilities.
- Office of Special Prosecutions: Prosecutes selected fish and game cases that are significant or have statewide importance. The remainder of fish and game cases are handled by the appropriate district attorney's office.
- Office of Special Prosecutions: Prosecutes environmental crimes through a reimbursable services agreement with the Department of Environmental Conservation (DEC). These prosecution services protect the state's air and water quality by providing advice and assistance to state environmental investigators and by prosecuting appropriate criminal cases.
- Office of Special Prosecutions: Prosecutes individuals who defraud the welfare system through a reimbursable services agreement with the Department of Health and Social Services (DHSS). These prosecution services protect the state's welfare system.
- Office of Special Prosecutions: Through a reimbursable services agreement with the Department of Revenue (DOR), prosecutes cases against individuals who fraudulently apply for a Permanent Fund Dividend (PFD). These prosecution efforts protect the integrity of the PFD program.
- Office of Special Prosecutions: Prosecutes criminal child support enforcement matters through a reimbursable services agreement with DOR.

Major Component Accomplishments in 2021

See Accomplishments at RDU level.

Key Component Challenges

See Key Challenges at RDU level.

Significant Changes in Results to be Delivered in FY2023

See Changes in Results at RDU level.

Statutory and Regulatory Authority

AS 44.23.020

Contact Information
<p>Contact: John Skidmore, Deputy Attorney General Phone: (907) 269-5100 E-mail: john.skidmore@alaska.gov</p>

Criminal Appeals/Special Litigation Personal Services Information				
Authorized Positions			Personal Services Costs	
	FY2022 Management Plan	FY2023 Governor		
Full-time	55	55	Annual Salaries	5,105,298
Part-time	0	0	COLA	2,928
Nonpermanent	0	0	Premium Pay	0
			Annual Benefits	2,984,027
			<i>Less 2.63% Vacancy Factor</i>	<i>(213,053)</i>
			Lump Sum Premium Pay	0
Totals	55	55	Total Personal Services	7,879,200

Position Classification Summary					
Job Class Title	Anchorage	Fairbanks	Juneau	Others	Total
Attorney 2	1	0	0	0	1
Attorney 3	5	0	0	0	5
Attorney 4	13	0	1	0	14
Attorney 5	11	0	0	0	11
Attorney 6	2	0	0	0	2
Forensic Accountant	1	0	0	0	1
Investigator 3	5	0	0	0	5
Investigator 4	1	0	0	0	1
Law Office Assistant 1	7	0	0	0	7
Law Office Assistant 2	2	0	0	0	2
Office Assistant 2	1	0	0	0	1
Paralegal 2	2	0	0	0	2
Victim/Witness Paralegal 1	1	0	0	0	1
Victim/Witness Paralegal 2	2	0	0	0	2
Totals	54	0	1	0	55

Component Detail All Funds
Department of Law

Component: Criminal Appeals/Special Litigation (2203)
RDU: Criminal Division (33)

Non-Formula Component

	FY2021 Actuals	FY2022 Conference Committee	FY2022 Authorized	FY2022 Management Plan	FY2023 Governor	FY2022 Management Plan vs FY2023 Governor	
71000 Personal Services	6,928.7	8,019.2	8,019.2	8,030.8	7,879.2	-151.6	-1.9%
72000 Travel	51.0	152.8	152.8	152.8	177.8	25.0	16.4%
73000 Services	903.5	636.8	636.8	636.8	686.8	50.0	7.9%
74000 Commodities	54.8	74.7	74.7	74.7	99.7	25.0	33.5%
75000 Capital Outlay	0.0	18.0	18.0	18.0	18.0	0.0	0.0%
77000 Grants, Benefits	0.0	0.0	0.0	0.0	0.0	0.0	0.0%
78000 Miscellaneous	0.0	0.0	0.0	0.0	0.0	0.0	0.0%
Totals	7,938.0	8,901.5	8,901.5	8,913.1	8,861.5	-51.6	-0.6%
Fund Sources:							
1002 Fed Rcpts (Fed)	1,594.9	2,035.5	2,035.5	2,035.5	2,047.5	12.0	0.6%
1003 G/F Match (UGF)	508.8	542.5	542.5	542.5	545.3	2.8	0.5%
1004 Gen Fund (UGF)	4,729.2	4,987.5	4,987.5	4,999.1	4,923.3	-75.8	-1.5%
1005 GF/Prgm (DGF)	0.7	23.0	23.0	23.0	23.0	0.0	0.0%
1007 I/A Rcpts (Other)	1,104.4	1,313.0	1,313.0	1,313.0	1,322.4	9.4	0.7%
Unrestricted General (UGF)	5,238.0	5,530.0	5,530.0	5,541.6	5,468.6	-73.0	-1.3%
Designated General (DGF)	0.7	23.0	23.0	23.0	23.0	0.0	0.0%
Other Funds	1,104.4	1,313.0	1,313.0	1,313.0	1,322.4	9.4	0.7%
Federal Funds	1,594.9	2,035.5	2,035.5	2,035.5	2,047.5	12.0	0.6%
Positions:							
Permanent Full Time	52	56	56	55	55	0	0.0%
Permanent Part Time	0	0	0	0	0	0	0.0%
Non Permanent	0	0	0	0	0	0	0.0%

Change Record Detail - Multiple Scenarios with Descriptions
Department of Law

Component: Criminal Appeals/Special Litigation (2203)
RDU: Criminal Division (33)

Scenario/Change Record Title	Trans Type	Totals	Personal Services	Travel	Services	Commodities	Capital Outlay	Grants, Benefits	Miscellaneous	Positions		NP
										PFT	PPT	
***** Changes From FY2022 Conference Committee To FY2022 Authorized *****												
FY2022 Conference Committee												
	ConfCom	8,901.5	8,019.2	152.8	636.8	74.7	18.0	0.0	0.0	56	0	0
1002 Fed Rcpts		2,035.5										
1003 G/F Match		542.5										
1004 Gen Fund		4,987.5										
1005 GF/Prgm		23.0										
1007 I/A Rcpts		1,313.0										
Subtotal		8,901.5	8,019.2	152.8	636.8	74.7	18.0	0.0	0.0	56	0	0
***** Changes From FY2022 Authorized To FY2022 Management Plan *****												
Transfer Attorney 5 (03-0110) to Second Judicial District for Required Legal Expertise												
	Trout	-75.0	-75.0	0.0	0.0	0.0	0.0	0.0	0.0	-1	0	0
1004 Gen Fund		-75.0										
Transfer one full-time Attorney 5 position (03-0110), range 25, located in Anchorage, to the Second Judicial District, Kotzebue office from Criminal Appeals/Special Litigation to keep pace with the required level of legal expertise needed within the office. The remaining staff in Criminal Appeals/Special Litigation are sufficient to accommodate anticipated workload.												
Transfer Attorney 4 (03-1319) from Second Judicial District for Required Legal Expertise												
	Trin	0.0	0.0	0.0	0.0	0.0	0.0	0.0	0.0	1	0	0
Transfer one full-time Attorney 4 position (03-1319), range 24, located in Kotzebue, to Criminal Appeals/Special Litigation, Anchorage office from the Second Judicial District to keep pace with the required level of legal expertise needed within the office. The remaining staff in the Second Judicial District are sufficient to accommodate anticipated workload.												
Transfer Attorney 5 (03-1280) to Criminal Justice Litigation for Required Legal Expertise												
	Trout	0.0	0.0	0.0	0.0	0.0	0.0	0.0	0.0	-1	0	0
Transfer one full-time Attorney 5 position (03-1280), range 25, located in Anchorage, to the Criminal Justice Litigation component from Criminal Appeals/Special Litigation to keep pace with the required level of legal expertise needed within the office. The remaining staff in Criminal Appeals/Special Litigation are sufficient to accommodate anticipated workload.												
Transfer Attorney 5 (03-1322) to Third Judicial District: Anchorage for Required Legal Expertise												
	Trout	-65.2	-65.2	0.0	0.0	0.0	0.0	0.0	0.0	-1	0	0
1004 Gen Fund		-65.2										
Transfer one full-time Attorney 5 position (03-1322), range 25, located in Anchorage, to the Third Judicial District: Anchorage from Criminal Appeals/Special Litigation to keep pace with the required level of legal expertise needed within the office. The remaining staff in Criminal Appeals/Special Litigation are sufficient to accommodate anticipated workload.												

Change Record Detail - Multiple Scenarios with Descriptions
Department of Law

Component: Criminal Appeals/Special Litigation (2203)
RDU: Criminal Division (33)

Scenario/Change Record Title	Trans Type	Totals	Personal Services	Travel	Services	Commodities	Capital Outlay	Grants, Benefits	Miscellaneous	Positions		NP
										PFT	PPT	
Transfer Attorney 6 (03-1058) from Criminal Justice Litigation for Required Legal Expertise												
1004 Gen Fund	Trin	151.8	151.8	0.0	0.0	0.0	0.0	0.0	0.0	1	0	0
Transfer one full-time Attorney 6 position (03-1058), range 26, located in Anchorage, from Criminal Justice Litigation to Criminal Appeals/Special Litigation to keep pace with the required level of legal expertise needed within the office. The remaining staff in Criminal Justice Litigation are sufficient to accommodate anticipated workload.												
Subtotal		8,913.1	8,030.8	152.8	636.8	74.7	18.0	0.0	0.0	55	0	0
***** Changes From FY2022 Management Plan To FY2023 Governor *****												
FY2023 Salary and Benefit Adjustments												
	SalAdj	3.0	3.0	0.0	0.0	0.0	0.0	0.0	0.0	0	0	0
1002 Fed Rcpts		1.2										
1003 G/F Match		0.4										
1004 Gen Fund		1.4										
FY2023 SU BU - Supervisory Employees (SS) 1% COLA: \$3.0												
FY2023 Executive Health Insurance, SBS, and Risk Management Rate Changes												
	SalAdj	62.3	62.3	0.0	0.0	0.0	0.0	0.0	0.0	0	0	0
1002 Fed Rcpts		8.1										
1003 G/F Match		1.5										
1004 Gen Fund		43.6										
1007 I/A Rcpts		9.1										
FY2023 Change Partially Exempt & Exempt Executive (EE) - Health Insurance from \$1,555 to \$1,685; SBS and Risk Management Rates: \$62.3												
FY2023 Supervisory Employees Health Insurance, SBS, and Risk Management Rate Changes												
	SalAdj	5.2	5.2	0.0	0.0	0.0	0.0	0.0	0.0	0	0	0
1002 Fed Rcpts		1.4										
1003 G/F Match		0.5										
1004 Gen Fund		3.3										
FY2023 Change Supervisory Employees (SS) - Health Insurance from \$1,555 to \$1,685; SBS and Risk Management Rates: \$5.2												
FY2023 General Government Unit SBS and Risk Management Rate Changes												
	SalAdj	3.1	3.1	0.0	0.0	0.0	0.0	0.0	0.0	0	0	0
1002 Fed Rcpts		1.3										
1003 G/F Match		0.4										
1004 Gen Fund		1.1										
1007 I/A Rcpts		0.3										

Change Record Detail - Multiple Scenarios with Descriptions
Department of Law

Component: Criminal Appeals/Special Litigation (2203)
RDU: Criminal Division (33)

Scenario/Change Record Title	Trans Type	Totals	Personal Services	Travel	Services	Commodities	Capital Outlay	Grants, Benefits	Miscellaneous	Positions		NP
										PFT	PPT	
FY2023 Change General Government Unit (GG, GP, GY, GZ) - SBS, and Risk Management Rates: \$3.1												
FY2023 PERS Actuarial Rate Adjustment to 24.79% Ch9 SLA2021 (SB55)												
	SalAdj	-267.9	-267.9	0.0	0.0	0.0	0.0	0.0	0.0	0	0	0
1002 Fed Rcpts		-54.7										
1003 G/F Match		-13.6										
1004 Gen Fund		-167.5										
1007 I/A Rcpts		-32.1										
Includes: FY2023 Adjustment for PERS ARM Board Approved Rate of 24.79% (from 30.11%): \$-267.9												
Fully Fund Positions Added in FY2022 to Combat Sexual Assault												
	Inc	142.7	142.7	0.0	0.0	0.0	0.0	0.0	0.0	0	0	0
1004 Gen Fund		142.7										
The Department of Law, Criminal Division added a number of full-time prosecutors and support staff positions in the FY2022 Governor's budget in order to increase the resources available to combat sexual assault and the sexual abuse of minors across Alaska. While accepted, these positions were three-quarter funded by the Legislature in the FY2022 enacted budget. This increment will fully-fund the positions and allow the department to maintain full-time employment of these positions.												
Realign PERS Rate Adjustment by Fund Source Ch9 SLA2021 (SB55)												
	FndChg	0.0	0.0	0.0	0.0	0.0	0.0	0.0	0.0	0	0	0
1002 Fed Rcpts		54.7										
1003 G/F Match		13.6										
1004 Gen Fund		-100.4										
1007 I/A Rcpts		32.1										
Fund source adjustments were made to this component in the SB55 fiscal note (Ch 9 SLA 2021) to accommodate the application of the actuarial PERS rate in FY2022. This transaction realigns fund sources to reduce the UGF subsidy assigned in the fiscal note.												
Transfer Authority to Travel, Services and Commodities for Anticipated Expenditures												
	LIT	0.0	-100.0	25.0	50.0	25.0	0.0	0.0	0.0	0	0	0
Transfer authority to the travel, services, and commodities lines from the personal services line from for anticipated costs. The remaining personal services authority is anticipated to be sufficient to cover operating expenditures.												
Totals		8,861.5	7,879.2	177.8	686.8	99.7	18.0	0.0	0.0	55	0	0

Line Item Detail (1676)
Department of Law
Travel

Component: Criminal Appeals/Special Litigation (2203)

Line Number	Line Name		FY2021 Actuals	FY2022 Management Plan	FY2023 Governor
2000	Travel		51.0	152.8	177.8
Object Class	Servicing Agency	Explanation	FY2021 Actuals	FY2022 Management Plan	FY2023 Governor
2000 Travel Detail Totals			51.0	152.8	177.8
2000	In-State Employee Travel	Travel for attorneys to interview witnesses and attend court proceedings, as well as for necessary training for both attorneys and paraprofessionals. Includes travel for management purposes.	36.3	60.0	70.0
2001	In-State Non-Employee Travel	Travel costs for witnesses to testify in court.	14.1	60.8	70.8
2002	Out of State Employee Travel	Travel costs and expenses for out-of-state travel for conferences, training, etc.	0.6	20.0	25.0
2005	Moving Costs	Moving costs.	0.0	12.0	12.0

Line Item Detail (1676)
Department of Law
Services

Component: Criminal Appeals/Special Litigation (2203)

Line Number	Line Name		FY2021 Actuals	FY2022 Management Plan	FY2023 Governor
3000	Services		903.5	636.8	686.8
Object Class	Servicing Agency	Explanation	FY2021 Actuals	FY2022 Management Plan	FY2023 Governor
3000 Services Detail Totals			903.5	636.8	686.8
3000	Education Services	Conferences, training and memberships.	37.0	50.0	40.0
3002	Legal and Judicial Services	Depositions, research costs, expert witness and consultant fees.	10.9	11.0	11.0
3003	Information Technology	Training, consulting and software licensing and maintenance. Annual maintenance fee for mission-critical information management systems.	3.8	4.0	4.0
3004	Telecommunications	Local telephone service, long distance charges and cellular phone services paid to third-party telephone utilities.	11.0	11.0	11.0
3006	Delivery Services	Freight, courier, postage, and transportation of trial exhibit materials.	1.0	1.0	1.0
3007	Advertising and Promotions	Publication of legal notices.	0.1	1.1	0.1
3008	Utilities	Waste management disposal costs not included in lease.	1.4	1.5	1.5
3011	Other Services	Cost transfers and miscellaneous items within the services line (commissions, etc.).	1.3	1.5	1.5
3013	Inter-Agency Data Processing Operations Allocation	Law - Administrative Services (2164) RSA Law, Information services, data processing investments and support.	19.4	20.0	20.0
3017	Inter-Agency Information Technology Non-Telecommunications	Admin - Department-wide RSA Administration, Office of Information Technology computer services.	207.7	208.0	208.0

Line Item Detail (1676)
Department of Law
Services

Component: Criminal Appeals/Special Litigation (2203)

Object Class	Servicing Agency	Explanation	FY2021 Actuals	FY2022 Management Plan	FY2023 Governor	
3000 Services Detail Totals			903.5	636.8	686.8	
3018	Inter-Agency Information Technology Telecommunications	Admin - Department-wide	RSA Administration, Office of Information Technology telecommunications services.	26.4	27.0	27.0
3022	Inter-Agency Human Resources	Law - Administrative Services (2164)	RSA Law, Human Resources position.	46.0	50.0	50.0
3023	Inter-Agency Building Leases	Admin - Department-wide	Leased office space managed by General Services.	521.7	233.7	294.7
3026	Inter-Agency Insurance	Admin - Department-wide	RSA Administration, Risk Management.	3.4	3.5	3.5
3027	Inter-Agency Financial	Admin - Department-wide	RSA Administration, Finance Chargeback (IRIS).	8.3	9.0	9.0
3028	Inter-Agency Americans with Disabilities Act Compliance	Admin - Department-wide	RSA Administration - Division of Personnel and Labor Relations, Americans with Disabilities Act.	0.4	0.5	0.5
3037	State Equipment Fleet	Trans - Department-wide	State vehicle maintenance and operations.	3.7	4.0	4.0

Line Item Detail (1676)
Department of Law
Commodities

Component: Criminal Appeals/Special Litigation (2203)

Line Number	Line Name		FY2021 Actuals	FY2022 Management Plan	FY2023 Governor
4000	Commodities		54.8	74.7	99.7
Object Class	Servicing Agency	Explanation	FY2021 Actuals	FY2022 Management Plan	FY2023 Governor
		4000 Commodities Detail Totals	54.8	74.7	99.7
4000	Business	Reference materials and subscriptions, including statutes, software applications, non-capital desktop refresh, and miscellaneous office supplies.	54.8	74.7	99.7

Line Item Detail (1676)
Department of Law
Capital Outlay

Component: Criminal Appeals/Special Litigation (2203)

Line Number	Line Name		FY2021 Actuals	FY2022 Management Plan	FY2023 Governor
5000	Capital Outlay		0.0	18.0	18.0
Object Class	Servicing Agency	Explanation	FY2021 Actuals	FY2022 Management Plan	FY2023 Governor
5000 Capital Outlay Detail Totals			0.0	18.0	18.0
5004	Equipment	Equipment purchases.	0.0	18.0	18.0

Revenue Detail (1681)
Department of Law

Component: Criminal Appeals/Special Litigation (2203)

Revenue Type (OMB Fund Code) Revenue Source	Component	Comment	FY2021 Actuals	FY2022 Management Plan	FY2023 Governor
5002 Fed Rcpts (1002 Fed Rcpts)			1,594.9	2,035.5	2,047.5
5014 Federal Public Protection - Miscellaneous Grants		Medicaid Fraud Control Unit. Program code: 03MEDFRAUD.	1,263.2	2,035.5	2,047.5
5014 Federal Public Protection - Miscellaneous Grants		Rural Prosecutions Unit. Program code: 03RURALPSU.	331.7	0.0	0.0
5005 GF/Prgm (1005 GF/Prgm)			0.7	23.0	23.0
5119 Program Receipts Law - Charges for Services		Discovery receipts - receipts from private attorneys.	0.7	23.0	23.0
5007 I/A Rcpts (1007 I/A Rcpts)			1,104.4	1,313.0	1,322.4
5301 Inter-Agency Receipts	EnvCon - Department-wide	RSA Environmental Conservation, Administrative Services - legal services for the Environmental Crimes Unit. Program code: CM03651705.	134.9	173.0	182.4
5301 Inter-Agency Receipts	Health - Department-wide	RSA Health and Social Services, Fraud Investigation - legal services provided to the Welfare Fraud Investigation Unit. Program code: CM03651800.	147.8	170.0	170.0
5301 Inter-Agency Receipts	Law - Commercial and Fair Business (2717)	RSA Law, Commercial and Fair Business - child support enforcement matters. Program code: CM03651707.	199.4	225.0	225.0
5301 Inter-Agency Receipts	PubSaf - Department-wide	RSA Public Safety, SAKI - Federal funds channeled through the Department of Public Safety for additional prosecution efforts in Alaska to combat the epidemic of sexual assault and domestic violence plaguing Alaska. Program code: CM0365SAKI.	24.2	35.0	35.0
5301 Inter-Agency Receipts	Rev - Department-wide	RSA Revenue, Permanent Fund Dividend - legal services for PFD and tax fraud cases. Program code:	186.1	225.0	225.0

Revenue Detail (1681)
Department of Law

Component: Criminal Appeals/Special Litigation (2203)

Revenue Type (OMB Fund Code) Revenue Source	Component	Comment	FY2021 Actuals	FY2022 Management Plan	FY2023 Governor
5301 Inter-Agency Receipts	PubSaf - Department-wide	CM03651801. RSA Public Safety, Alcohol Interdiction - Federal funds channeled through the Department of Public Safety for additional prosecution efforts in Alaska to reduce violent crime, accidental deaths and incidence of FAS and FAE by cutting off the easy availability through aggressive investigation and prosecution of bootlegging offenses in rural Alaska. Program code: CM03651750.	174.6	185.0	185.0
5301 Inter-Agency Receipts	PubSaf - Department-wide	RSA Public Safety - legal services for the Department of Public Safety. Program code: CM03651675.	46.6	75.0	75.0
5301 Inter-Agency Receipts	PubSaf - Department-wide	RSA Public Safety, HIDTA - Federal funds channeled through the Department of Public Safety for additional prosecution efforts in Alaska to combat the opioid crisis throughout the state under the High-Intensity Drug Trafficking Area (HIDTA) designation. Program code: CM036HIDTA.	190.8	225.0	225.0

Inter-Agency Services (1682)
Department of Law

Component: Criminal Appeals/Special Litigation (2203)

				FY2021 Actuals	FY2022 Management Plan	FY2023 Governor
Component Totals				837.0	555.7	616.7
With Department of Law				65.4	70.0	70.0
With Department of Administration				767.9	481.7	542.7
With Department of Transportation/Public Facilities				3.7	4.0	4.0
Object Class	Servicing Agency	Explanation		FY2021 Actuals	FY2022 Management Plan	FY2023 Governor
3013	Inter-Agency Data Processing Operations Allocation	Law - Administrative Services (2164)	RSA Law, Information services, data processing investments and support.	19.4	20.0	20.0
3017	Inter-Agency Information Technology Non-Telecommunications	Admin - Department-wide	RSA Administration, Office of Information Technology computer services.	207.7	208.0	208.0
3018	Inter-Agency Information Technology Telecommunications	Admin - Department-wide	RSA Administration, Office of Information Technology telecommunications services.	26.4	27.0	27.0
3022	Inter-Agency Human Resources	Law - Administrative Services (2164)	RSA Law, Human Resources position.	46.0	50.0	50.0
3023	Inter-Agency Building Leases	Admin - Department-wide	Leased office space managed by General Services.	521.7	233.7	294.7
3026	Inter-Agency Insurance	Admin - Department-wide	RSA Administration, Risk Management.	3.4	3.5	3.5
3027	Inter-Agency Financial	Admin - Department-wide	RSA Administration, Finance Chargeback (IRIS).	8.3	9.0	9.0
3028	Inter-Agency Americans with Disabilities Act Compliance	Admin - Department-wide	RSA Administration - Division of Personnel and Labor Relations, Americans with Disabilities Act.	0.4	0.5	0.5
3037	State Equipment Fleet	Trans - Department-wide	State vehicle maintenance and operations.	3.7	4.0	4.0

Personal Services Expenditure Detail
Department of Law

Scenario: FY2023 Governor (18673)
Component: Criminal Appeals/Special Litigation (2203)
RDU: Criminal Division (33)

PCN	Job Class Title	Time Status	Retire Code	Barg Unit	Location	Salary Sched	Range / Step	Comp Months	Split / Count	Annual Salaries	COLA	Premium Pay	Annual Benefits	Total Costs	UGF Amount
03-0093	Law Office Assistant 1	FT	A	GP	Anchorage	200	11B / C	12.0		39,111	0	0	33,342	72,453	0
03-0265	Attorney 3	FT	A	XE	Anchorage	N00	22E / F	12.0		90,007	0	0	53,747	143,754	0
03-0278	Law Office Assistant 1	FT	A	GP	Anchorage	200	11D / E	12.0		42,378	0	0	34,559	76,937	19,234
03-0282	Attorney 5	FT	A	XE	Anchorage	N00	25Q / R	12.0		151,383	0	0	76,310	227,693	56,923
03-0283	Investigator 3	FT	A	GP	Anchorage	200	18D / E	12.0		67,208	0	0	43,803	111,011	27,753
03-0284	Investigator 3	FT	A	GP	Anchorage	200	18G	12.0		73,769	0	0	46,246	120,015	30,004
03-0285	Forensic Accountant	FT	A	GP	Anchorage	200	24G / J	12.0		113,422	0	0	61,008	174,430	43,608
03-0350	Attorney 2	FT	A	XE	Anchorage	N00	20E / F	12.0		80,788	0	0	50,315	131,103	131,103
03-1022	Attorney 4	FT	A	XE	Anchorage	N00	24B / C	12.0		95,282	0	0	55,711	150,993	0
03-1026	Attorney 6	FT	A	XE	Anchorage	N00	26S / T	12.0		164,080	0	0	80,259	244,339	244,339
03-1028	Victim/Witness Paralegal 2	FT	A	GP	Anchorage	200	16C / D	12.0		56,427	0	0	39,789	96,216	96,216
03-1058	Attorney 6	FT	A	XE	Anchorage	N00	26R / S	12.0		159,648	0	0	78,881	238,529	238,529
03-1061	Attorney 5	FT	A	XE	Anchorage	N00	25O	12.0		138,626	0	0	71,848	210,474	210,474
03-1075	Law Office Assistant 1	FT	A	GP	Anchorage	200	11J	12.0		47,424	0	0	36,437	83,861	83,861
03-1077	Attorney 4	FT	A	XE	Anchorage	N00	24J	12.0		109,902	0	0	61,154	171,056	171,056
03-1079	Attorney 5	FT	A	XE	Anchorage	N00	25K / L	12.0		125,106	0	0	66,814	191,920	191,920
03-1095	Law Office Assistant 2	FT	A	SS	Anchorage	600	13C / D	12.0		50,138	688	0	39,048	89,874	89,874
03-1104	Attorney 4	FT	A	XE	Anchorage	N00	24F	12.0		106,451	0	0	59,869	166,320	166,320
03-1110	Paralegal 2	FT	A	GP	Anchorage	200	16M / N	12.0		74,663	0	0	46,578	121,241	59,408
03-1130	Attorney 5	FT	A	XE	Anchorage	99	25R / S	12.0		152,345	0	0	76,609	228,954	228,954
03-1157	Attorney 4	FT	A	XE	Anchorage	N00	24F	12.0		106,451	0	0	59,869	166,320	166,320
03-1191	Attorney 4	FT	A	XE	Anchorage	N00	24J / K	12.0		111,547	0	0	61,766	173,313	173,313
03-1227	Law Office Assistant 1	FT	A	GP	Anchorage	200	11L	12.0		50,564	0	0	37,606	88,170	88,170
03-1240	Attorney 3	FT	A	XE	Anchorage	N00	22J	12.0		95,979	0	0	55,970	151,949	151,949
03-1247	Attorney 3	FT	A	XE	Anchorage	N00	22D / E	12.0		87,516	0	0	52,819	140,335	0
03-1248	Investigator 3	FT	A	GP	Anchorage	200	18F / G	12.0		73,674	0	0	46,210	119,884	29,971
03-1250	Attorney 4	FT	A	XE	Anchorage	N00	24M	12.0		120,978	0	0	65,277	186,255	186,255
03-1254	Attorney 4	FT	A	XE	Anchorage	N00	24F / J	12.0		107,716	0	0	60,340	168,056	42,014
03-1263	Attorney 3	FT	A	XE	Anchorage	N00	22F / J	12.0		94,846	0	0	55,548	150,394	0
03-1266	Attorney 5	FT	A	XE	Anchorage	N00	25F	12.0		114,426	0	0	62,838	177,264	44,316
03-1267	Attorney 4	FT	A	XE	Anchorage	N00	24J / K	12.0		110,650	0	0	61,432	172,082	172,082
03-1271	Attorney 4	FT	A	XE	Anchorage	N00	24E / F	12.0		106,306	0	0	59,815	166,121	166,121
03-1278	Paralegal 2	FT	A	GP	Anchorage	200	16D / E	12.0		59,793	0	0	41,042	100,835	25,209
03-1279	Attorney 5	FT	A	XE	Anchorage	N00	25C / D	12.0		105,438	0	0	59,492	164,930	164,930
03-1283	Law Office Assistant 1	FT	A	GP	Anchorage	200	11E / F	12.0		43,374	0	0	34,929	78,303	11,746
03-1293	Victim/Witness Paralegal 2	FT	A	GP	Anchorage	200	16K / L	12.0		71,266	0	0	45,314	116,580	116,580
03-1295	Attorney 4	FT	A	XE	Anchorage	N00	24J / K	12.0		113,191	0	0	62,378	175,569	175,569
03-1298	Attorney 5	FT	A	XE	Anchorage	N00	25P	12.0		143,130	0	0	73,525	216,655	216,655

Note: If a position is split, an asterisk (*) will appear in the Split/Count column. If the split position is also counted in the component, two asterisks (**) will appear in this column. [No valid job title] appearing in the Job Class Title indicates that the PCN has an invalid class code or invalid range for the class code effective date of this scenario.

Personal Services Expenditure Detail
Department of Law

Scenario: FY2023 Governor (18673)
Component: Criminal Appeals/Special Litigation (2203)
RDU: Criminal Division (33)

PCN	Job Class Title	Time Status	Retire Code	Barg Unit	Location	Salary Sched	Range / Step	Comp Months	Split / Count	Annual Salaries	COLA	Premium Pay	Annual Benefits	Total Costs	UGF Amount
03-1302	Attorney 3	FT	A	XE	Anchorage	N00	22F	12.0		92,957	0	0	54,845	147,802	147,802
03-1303	Law Office Assistant 2	FT	A	SS	Anchorage	600	13E / F	12.0		53,537	735	0	40,313	94,585	94,585
03-1310	Investigator 3	FT	A	GP	Anchorage	200	18B / C	12.0		64,168	0	0	42,671	106,839	26,710
03-1311	Investigator 3	FT	A	GP	Anchorage	200	18D / E	12.0		68,218	0	0	44,179	112,397	28,099
03-1312	Investigator 4	FT	A	SS	Anchorage	99	20O	12.0		109,695	1,505	0	61,221	172,421	43,105
03-1319	Attorney 4	FT	A	XE	Anchorage	N00	24K / L	12.0		114,719	0	0	62,947	177,666	177,666
03-1323	Attorney 4	FT	A	XE	Anchorage	N00	24C / D	12.0		99,063	0	0	57,118	156,181	156,181
03-1324	Attorney 5	FT	A	XE	Anchorage	N00	25M	12.0		130,026	0	0	68,646	198,672	0
03-1330	Law Office Assistant 1	FT	A	GP	Anchorage	200	11C / D	12.0		40,524	0	0	33,868	74,392	74,392
03-1337	Attorney 5	FT	A	XE	Anchorage	N00	25F / J	12.0		116,248	0	0	63,516	179,764	179,764
03-1344	Attorney 4	FT	A	XE	Anchorage	N00	24F	12.0		106,451	0	0	59,869	166,320	0
03-1345	Attorney 4	FT	A	XE	Juneau	N05	24F / J	12.0		115,099	0	0	63,089	178,188	0
03-1346	Law Office Assistant 1	FT	A	GP	Anchorage	200	11B / C	12.0		39,205	0	0	33,377	72,582	0
03-1360	Victim/Witness Paralegal 1	FT	A	GP	Anchorage	100	14A / B	12.0		46,841	0	0	36,220	83,061	83,061
03-1368	Attorney 5	FT	A	XE	Anchorage	N00	25D / E	12.0		108,220	0	0	60,528	168,748	168,748
03-1369	Attorney 5	FT	A	XE	Anchorage	N00	25D / E	12.0		108,220	0	0	60,528	168,748	168,748
03-1373	Office Assistant 2	FT	A	GP	Anchorage	100	10B / C	12.0		37,104	0	0	32,595	69,699	69,699
													Total Salary Costs:	5,105,298	
													Total COLA:	2,928	
													Total Premium Pay:	0	
													Total Benefits:	2,984,027	
													Total Pre-Vacancy:	8,092,253	
													Minus Vacancy Adjustment of 2.63%:	(213,053)	
													Total Post-Vacancy:	7,879,200	
													Plus Lump Sum Premium Pay:	0	
													Personal Services Line 100:	7,879,200	
													Total Component Months:	660.0	

PCN Funding Sources:	Pre-Vacancy	Post-Vacancy	Percent
1002 Federal Receipts	1,667,927	1,624,013	20.61%
1003 General Fund Match	416,946	405,968	5.15%
1004 General Fund Receipts	5,022,390	4,890,160	62.06%
1007 Interagency Receipts	984,991	959,059	12.17%
Total PCN Funding:	8,092,253	7,879,200	100.00%

Note: If a position is split, an asterisk (*) will appear in the Split/Count column. If the split position is also counted in the component, two asterisks (**) will appear in this column. [No valid job title] appearing in the Job Class Title indicates that the PCN has an invalid class code or invalid range for the class code effective date of this scenario.

CRIMINAL DIVISION

Criminal Appeals/Special Litigation 1 of 2

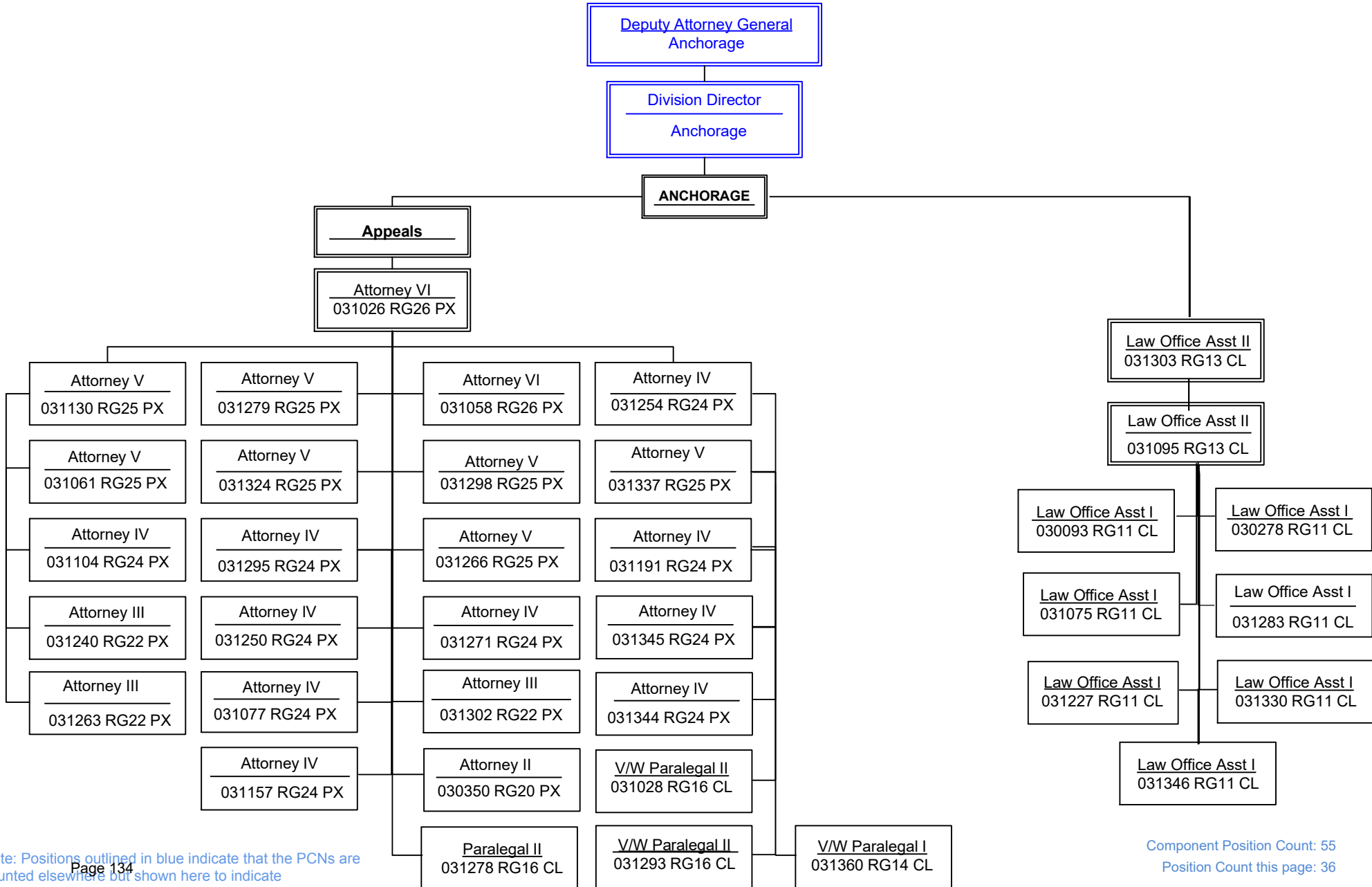

Note: Positions outlined in blue indicate that the PCNs are counted elsewhere but shown here to indicate organizational hierarchy.

Component Position Count: 55
Position Count this page: 36

CRIMINAL DIVISION

Criminal Appeals/Special Litigation 2 of 2

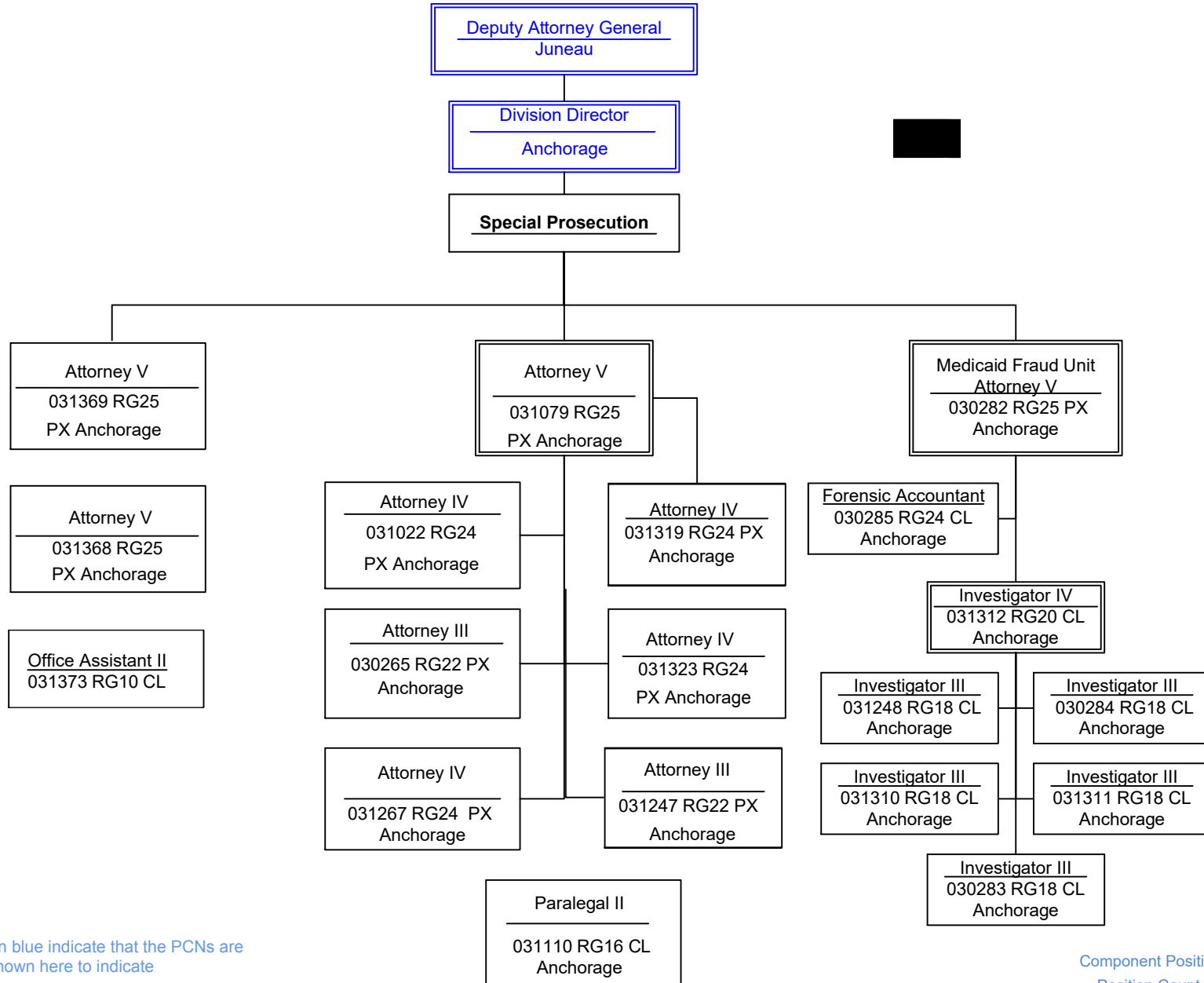

State of Alaska
FY2023 Governor's Operating Budget

Department of Law
Civil Division (Excludes Janus)
Results Delivery Unit Budget Summary

Civil Division (Excludes Janus) Results Delivery Unit

Contribution to Department's Mission

The mission of the Civil Division is to protect the human, financial and natural resources of the state.

Results

(Additional performance information is available on the web at <https://omb.alaska.gov/results>.)

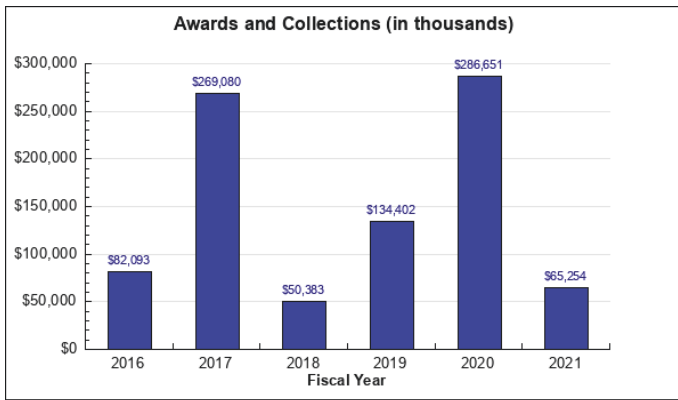
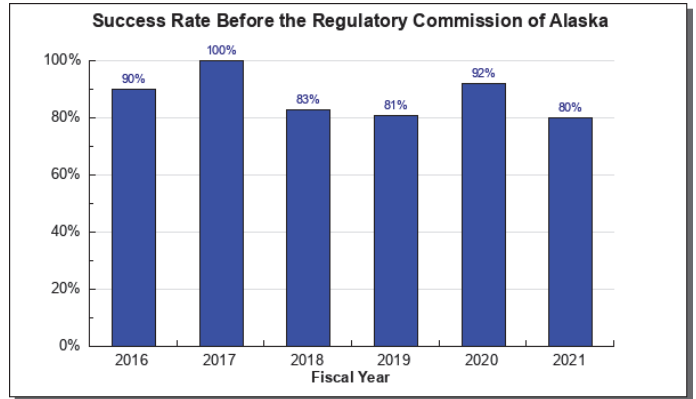
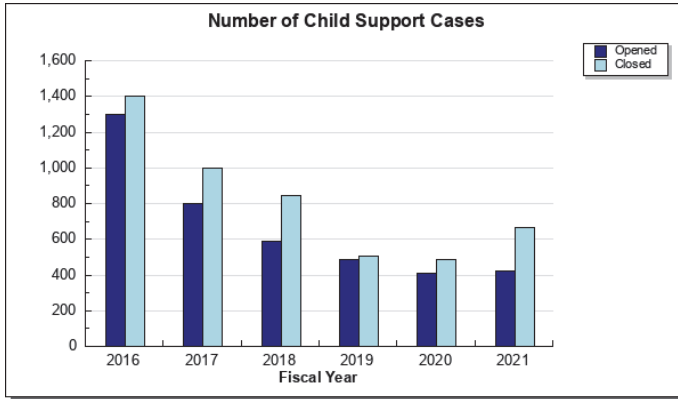

Core Services

- Protecting the safety and physical and financial well-being of Alaskans
- Maximize tax and royalty claims
- Promoting good governance

Measures by Core Service

(Additional performance information is available on the web at <https://omb.alaska.gov/results>.)

1. Protecting the safety and physical and financial well-being of Alaskans

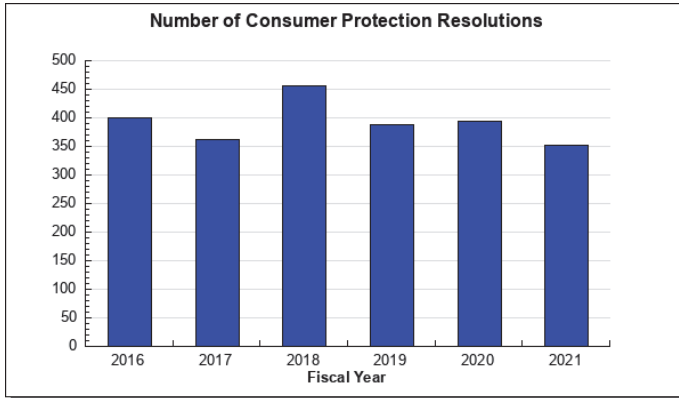

2. Maximize tax and royalty claims

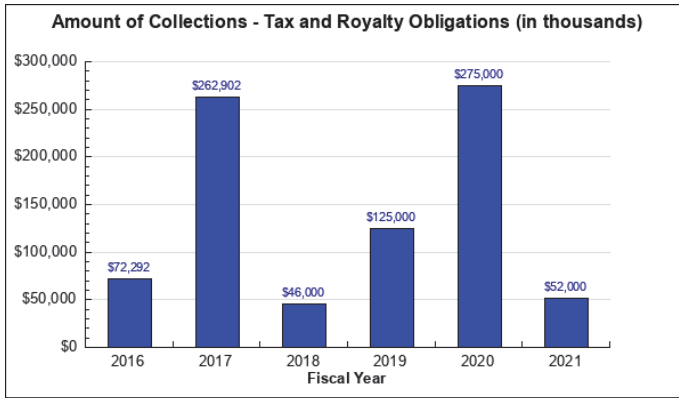

3. Promoting good governance

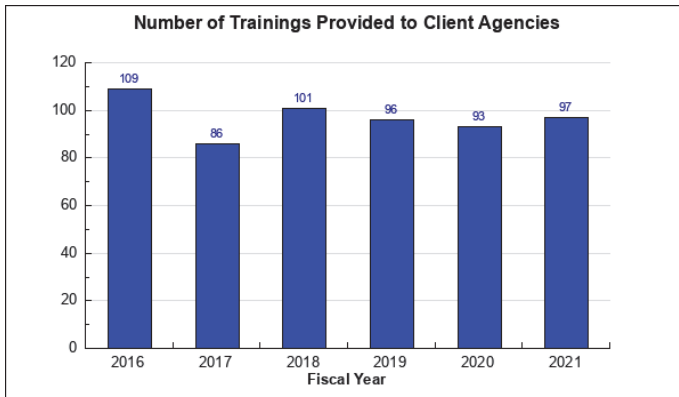

Major RDU Accomplishments in 2021

Protecting the Safety and Physical and Financial Well-being of Alaskans

- Child Protection. In FY2021, the section managed very substantial Child-In-Need-of-Aid (CINA) caseloads while working to improve the child protection system and foster state-tribal relations to better protect children. The section primarily litigates cases at the trial court level with 25 attorneys to handle approximately 3,100 individual CINA cases.

- Human Services. The section continued to advise DHSS on the implementation of Ch. 25 SLA 2016 (SB 74, Medicaid Reform), including the implementation of the 1115 Waiver to transform the behavioral health system in Alaska, estimated to save the state millions of general fund dollars in the coming fiscal years. The section also handled many contested evidentiary hearings statewide related to guardianships, conservatorships and mental commitments.
- Commercial and Fair Business Practices. The attorneys in this section successfully prosecuted or negotiated settlements in 25 professional discipline, license denial, license reinstatement, and unlicensed activity matters. These cases resulted in various actions including revocation, surrender, fines, reprimand, suspension, license conditions, or denial of a license.
- Regulatory Affairs and Public Advocacy (RAPA). The section's advocacy yielded approximately \$1.5 million in quantifiable consumer benefits in FY2021. This figure is based on refunds issued or the difference between the amounts requested by utilities in their respective revenue requirement proposals and the amounts ultimately awarded to them by the Regulatory Commission of Alaska.

Fostering the Conditions for Economic Opportunity and Responsible Development and Use of Alaska's Natural Resources

- Labor and State Affairs. The section assisted the Alaska Industrial Development and Export Authority on issues about development of the Ambler Mining District industrial access road and the West Susitna access road, and Section 1002 Arctic National Wildlife Refuge.
- Natural Resources. Section attorneys litigated against federal agencies to challenge National Park Service and U.S. Fish and Wildlife Service regulations that prohibit the state from exercising its full authority to manage fish and game within federal parks and refuges.
- Transportation. Section attorneys are providing legal support for the Department of Transportation and Public Facilities land acquisition for highway and airport projects throughout Alaska, and in right-of-way acquisitions for major projects on the Parks, Glenn, Seward, and Richardson Highways, Knik-Goose Bay Road, and in the City of Fairbanks.

Protecting the Fiscal Integrity of the State

- Torts and Workers' Compensation. The section defended the state (as an employer) in numerous workers' compensation matters before the Alaska Workers' Compensation Board and the Alaska Workers' Compensation Appeals Commission, and defended the state, its agencies, and its employees in numerous state and federal court tort cases.
- Natural Resources. In FY2021, the section's work resulted in the collection of over \$52 million in additional tax and royalty payments, and attorney's fees.
- Labor and State Affairs. Section attorneys provided extensive legal advice and representation to the Department of Administration, Division of Retirement and Benefits, in numerous health and benefits appeals and coverage issues under the state's health care plans, and on proposed state health and pension plan changes.
- Transportation. Section attorneys defended multiple contractor claims filed against the Department of Transportation and Public Facilities. Included among the larger cases were claims arising from road construction and airport projects in the Central and Southeast regions.

Promoting and Defending Good Governance

- Labor and State Affairs. The section advised the Office of the Lieutenant Governor on issues, litigation, legislation, and regulations stemming from the 2020 election cycle and implementation of the ranked choice voting initiative.

- Opinions, Appeals and Ethics. The section promoted and enforced compliance with the Alaska Executive Branch Ethics Act by advising individuals and agencies on ethics questions, presenting ethics trainings, drafting ethics opinions and memoranda of advice, and investigating and resolving ethics complaints against former or current state employees.
- Opinions, Appeals and Ethics. The section filed an amicus brief in the U.S. Supreme Court in support of Alaska Native Corporations' ability to receive CARES Act funds.
- Legislation and Regulations. Coordinated and drafted legislative bills on behalf of the administration for the 32nd legislative session, including four special sessions.
- Labor and State Affairs. Along with other attorneys in the department, advised the Office of the Governor, the Department of Administration, the Department of Commerce, Community, and Economic Development, the Office of Management and Budget, and other agencies regarding application of the Disaster Act during the pandemic and the distribution of federal funds to the state to mitigate impacts from the pandemic.

Key RDU Challenges

Protecting children, vulnerable adults and consumers is at the core of the Civil Division's mission to protect both the physical and financial well-being of Alaskans.

- Child Protection. Shrinking division resources and increasing caseloads on a statewide basis are presenting significant challenges for the section. High attorney caseloads and shrinking resources increase costs to the state and lead to longer stays in foster care for children who could otherwise find permanency in their "forever home." The limited resources and growing caseloads could also negatively impact the amount of federal Title IV-E dollars the state is entitled to receive in reimbursement for eligible legal services performed in CINA cases, thereby increasing the amount of general funds needed to perform the work.
- Consumer Protection. Alaska is a target state for many types of consumer fraud. Under the authority of the Consumer Protection Act (AS 45.50.471 et seq.), the state section investigates and brings enforcement action against businesses that engage in unfair or deceptive trade practices. Because of vacancies and current budget constraints, the department's consumer protection enforcement capacity has been significantly limited in the last few years. Collaboration between the Commercial and Fair Business section and the Special Litigation section to increase its consumer protection enforcement functions continues.
- Human Services. Due to budget contractions, the section anticipates a significant increase in the number and complexity of regulations projects designed to address budget reductions and to create additional efficiencies in the administration of all Department of Health and Social Services programs. These regulation projects will likely generate litigation as change to programs and funding streams are implemented in the coming fiscal year.

Fostering the Conditions for Economic Opportunity and Responsible Development and Use of Natural Resources

- Environmental Law. Position reductions have resulted in a drop in cost recovery for Department of Environmental Conservation oversight and cleanup costs of spill response and contaminated sites. Reductions have also limited the ability to pursue cleanup of "lingering contaminated sites" where there is no responsible party undertaking a cleanup.
- Natural Resources. Defending the state's interests and goals from increasing restrictions under federal statutes and regulations continues to expand the section's caseload and requires strategically selecting the cases for litigation that are most likely to achieve the state's goals.

Protecting the Fiscal Integrity of the State

- Labor and State Affairs. Prior to the pandemic, the section's attorneys already had full workloads, and the pandemic has only increased these workloads and required a lot of urgent work in areas such as emergency

regulations, health mandates, administrative orders, etc. These higher workloads are likely to continue in light of the ongoing pandemic and uncertainty on when it might end.

- Natural Resources. The section is pursuing hundreds of millions of dollars in past-due taxes, interest and penalties owed by oil and gas producers and other corporate taxpayers. Representing the Department of Natural Resources in royalty disputes and negotiations to ensure that the state receives the appropriate share of royalties and net profit share from production continues to be a challenge with reduced staffing.
- Natural Resources. Defending the state's interests and goals from increasing restrictions under federal statutes and regulations as well as lawsuits from environmental groups to broaden the reach of federal laws continues to expand the section's caseload, and requires strategically selecting those cases for litigation that are most likely to achieve the state's goals.

Promoting and Defending Good Governance

- Information and Project Support. A key challenge for the section is advising and training personnel on protecting confidential and protected information for various agencies across the state. As programs are reduced or eliminated and staffing cuts pose a workload issue, it is a major challenge to provide guidance to state agencies on how to appropriately evaluate records and other materials for confidential or protected information prior to retention or disposal actions. Additionally, in the age of electronic communication, the number of records responsive to Public Records Act requests has exponentially increased, resulting in a much heavier workload for this section and agencies reviewing records.
- Opinions, Appeals and Ethics. A key challenge for the section is to lend its expertise in appellate briefing and argument to all Civil Division sections, given the volume of appeals to which the state is a party. At any given time, the Civil Division has between 100 and 150 civil appeals pending, 25-30 of which are child protection cases involving child abuse and neglect. The section directly handles all of the child protection appeals statewide, as well as all appeals of civil commitments statewide. The section also directly handles appeals in cases that concern constitutional and legal issues of particular import.

Significant Changes in Results to be Delivered in FY2023

The division is continuously assessing how it can better provide legal services to state agencies and litigate matters in the public interest. The division makes every effort to prioritize and direct limited available resources in order to ensure efficiency while preserving effectiveness.

Contact Information
<p>Contact: Treg Taylor, Deputy Attorney General Phone: (907) 269-5100 E-mail: treg.taylor@alaska.gov</p>

**Civil Division (Excludes Janus)
RDU Financial Summary by Component**

All dollars shown in thousands

	FY2021 Actuals				FY2022 Management Plan				FY2023 Governor			
	UGF+DGF Funds	Other Funds	Federal Funds	Total Funds	UGF+DGF Funds	Other Funds	Federal Funds	Total Funds	UGF+DGF Funds	Other Funds	Federal Funds	Total Funds
Formula Expenditures None.												
Non-Formula Expenditures												
Dep. Attny General's Office	1,943.8	0.0	0.0	1,943.8	4,289.3	10.0	0.0	4,299.3	4,283.4	10.0	0.0	4,293.4
Child Protection	6,083.5	3,679.9	0.0	9,763.4	5,568.5	2,245.1	0.0	7,813.6	5,381.1	2,264.4	0.0	7,645.5
Commercial and Fair Business	569.3	4,141.6	0.0	4,710.9	945.8	3,786.0	0.0	4,731.8	855.1	4,034.2	0.0	4,889.3
Environmental Law	161.8	999.5	0.0	1,161.3	764.9	1,241.8	0.0	2,006.7	717.2	1,252.9	0.0	1,970.1
Human Services	1,959.0	1,294.8	0.0	3,253.8	1,789.5	1,647.2	0.0	3,436.7	1,701.3	1,658.9	0.0	3,360.2
Labor and State Affairs	4,082.7	2,895.4	0.0	6,978.1	1,600.2	3,098.1	0.0	4,698.3	1,488.9	3,121.3	0.0	4,610.2
Legislation/Regulations	912.9	223.5	0.0	1,136.4	1,329.3	421.9	0.0	1,751.2	1,287.6	425.8	0.0	1,713.4
Natural Resources	2,270.6	3,985.2	0.0	6,255.8	4,236.0	3,947.7	0.0	8,183.7	4,125.4	3,966.8	0.0	8,092.2
Opinions, Appeals and Ethics	513.0	0.0	0.0	513.0	1,406.0	1,028.4	0.0	2,434.4	1,347.1	1,039.1	0.0	2,386.2
Reg Affairs Public Advocacy	2,392.7	0.0	0.0	2,392.7	2,933.8	0.0	0.0	2,933.8	2,892.2	0.0	0.0	2,892.2
Special Litigation	4.8	0.0	0.0	4.8	1,239.5	671.3	0.0	1,910.8	1,198.9	679.1	0.0	1,878.0
Information and Project Support	47.1	2,062.5	0.0	2,109.6	519.4	1,695.4	0.0	2,214.8	457.6	1,708.1	0.0	2,165.7
Torts and Workers' Compensation	10.6	3,790.0	0.0	3,800.6	219.6	4,300.1	0.0	4,519.7	75.4	4,344.9	0.0	4,420.3
Transportation Section	4.6	1,981.6	0.0	1,986.2	112.5	2,983.2	0.0	3,095.7	26.2	2,779.5	0.0	2,805.7
Totals	20,956.4	25,054.0	0.0	46,010.4	26,954.3	27,076.2	0.0	54,030.5	25,837.4	27,285.0	0.0	53,122.4

Civil Division (Excludes Janus)
Summary of RDU Budget Changes by Component
From FY2022 Management Plan to FY2023 Governor

All dollars shown in thousands

	<u>Unrestricted Gen (UGF)</u>	<u>Designated Gen (DGF)</u>	<u>Other Funds</u>	<u>Federal Funds</u>	<u>Total Funds</u>
FY2022 Management Plan	24,227.8	2,726.5	27,076.2	0.0	54,030.5
Adjustments which get you to start of year:					
-Dep. Attny General's Office	4,000.0	0.0	0.0	0.0	4,000.0
One-time items:					
-Dep. Attny General's Office	-4,000.0	0.0	0.0	0.0	-4,000.0
Adjustments which continue current level of service:					
-Dep. Attny General's Office	-5.9	0.0	0.0	0.0	-5.9
-Child Protection	-187.4	0.0	19.3	0.0	-168.1
-Commercial and Fair Business	-91.2	0.5	248.2	0.0	157.5
-Environmental Law	-47.7	0.0	11.1	0.0	-36.6
-Human Services	-88.2	0.0	11.7	0.0	-76.5
-Labor and State Affairs	-111.3	0.0	23.2	0.0	-88.1
-Legislation/Regulations	-41.7	0.0	3.9	0.0	-37.8
-Natural Resources	-110.6	0.0	19.1	0.0	-91.5
-Opinions, Appeals and Ethics	-58.9	0.0	10.7	0.0	-48.2
-Reg Affairs Public Advocacy	-2.1	-39.5	0.0	0.0	-41.6
-Special Litigation	-40.6	0.0	7.8	0.0	-32.8
-Information and Project Support	-61.8	0.0	12.7	0.0	-49.1
-Torts and Workers' Compensation	-144.2	0.0	44.8	0.0	-99.4
-Transportation Section	-86.3	0.0	-203.7	0.0	-290.0
FY2023 Governor	23,149.9	2,687.5	27,285.0	0.0	53,122.4

**State of Alaska
FY2023 Governor's Operating Budget**

**Department of Law
Deputy Attorney General's Office
Component Budget Summary**

Component: Deputy Attorney General's Office

Contribution to Department's Mission

The Deputy Attorney General oversees the operations of the Civil Division.

Core Services

- The Deputy Attorney General serves as the chief operating officer of the Civil Division, heading up the management team. The Civil Division Deputy works closely with the Criminal Division's Deputy Attorney General, the Civil and Criminal Division Directors, and statewide section supervisors, and is responsible for leading, managing, and coordinating the activities of the attorneys and staff in all of the Civil Division's seven office locations across the state.
- The Deputy Attorney General works directly on issues and cases that may require input or direction from the Attorney General or other policy-level officers.
- The Deputy Attorney General is responsible for presenting and defending the Civil Division's budget and its judgments and claims to the Legislature, and is responsible for making and implementing decisions on budget and staffing throughout the fiscal year.

Major Component Accomplishments in 2021

See Major RDU Accomplishments for Civil Division.

Key Component Challenges

See Key RDU Challenges for the Civil Division.

Significant Changes in Results to be Delivered in FY2023

The Deputy Attorney General's Office does not anticipate any significant changes in the next fiscal year.

Statutory and Regulatory Authority

AS 44.23.020

Contact Information

Contact: Cori Mills, Deputy Attorney General
Phone: (907) 465-3600
E-mail: cori.mills@alaska.gov

Deputy Attorney General's Office Personal Services Information				
Authorized Positions			Personal Services Costs	
	<u>FY2022</u> <u>Management</u> <u>Plan</u>	<u>FY2023</u> <u>Governor</u>		
Full-time	1	1	Annual Salaries	153,881
Part-time	0	0	Premium Pay	0
Nonpermanent	0	0	Annual Benefits	77,087
			<i>Less 1.67% Vacancy Factor</i>	(3,868)
			Lump Sum Premium Pay	0
Totals	1	1	Total Personal Services	227,100

Position Classification Summary					
Job Class Title	Anchorage	Fairbanks	Juneau	Others	Total
Deputy Attorney General	0	0	1	0	1
Totals	0	0	1	0	1

Component Detail All Funds
Department of Law

Component: Deputy Attorney General's Office (2205)
RDU: Civil Division (Excludes Janus) (35)

Non-Formula Component

	FY2021 Actuals	FY2022 Conference Committee	FY2022 Authorized	FY2022 Management Plan	FY2023 Governor	FY2022 Management Plan vs FY2023 Governor	
71000 Personal Services	1,458.6	261.0	261.0	233.0	227.1	-5.9	-2.5%
72000 Travel	0.4	19.8	19.8	19.8	19.8	0.0	0.0%
73000 Services	350.3	15.5	4,015.5	4,043.5	4,043.5	0.0	0.0%
74000 Commodities	134.4	3.0	3.0	3.0	3.0	0.0	0.0%
75000 Capital Outlay	0.1	0.0	0.0	0.0	0.0	0.0	0.0%
77000 Grants, Benefits	0.0	0.0	0.0	0.0	0.0	0.0	0.0%
78000 Miscellaneous	0.0	0.0	0.0	0.0	0.0	0.0	0.0%
Totals	1,943.8	299.3	4,299.3	4,299.3	4,293.4	-5.9	-0.1%
Fund Sources:							
1004 Gen Fund (UGF)	1,943.8	279.3	4,279.3	4,279.3	4,273.4	-5.9	-0.1%
1005 GF/Prgm (DGF)	0.0	10.0	10.0	10.0	10.0	0.0	0.0%
1007 I/A Rcpts (Other)	0.0	10.0	10.0	10.0	10.0	0.0	0.0%
Unrestricted General (UGF)	1,943.8	279.3	4,279.3	4,279.3	4,273.4	-5.9	-0.1%
Designated General (DGF)	0.0	10.0	10.0	10.0	10.0	0.0	0.0%
Other Funds	0.0	10.0	10.0	10.0	10.0	0.0	0.0%
Federal Funds	0.0	0.0	0.0	0.0	0.0	0.0	0.0%
Positions:							
Permanent Full Time	1	1	1	1	1	0	0.0%
Permanent Part Time	0	0	0	0	0	0	0.0%
Non Permanent	0	0	0	0	0	0	0.0%

Change Record Detail - Multiple Scenarios with Descriptions
Department of Law

Component: Deputy Attorney General's Office (2205)
RDU: Civil Division (Excludes Janus) (35)

Scenario/Change Record Title	Trans Type	Totals	Personal Services	Travel	Services	Commodities	Capital Outlay	Grants, Benefits	Miscellaneous	Positions		NP
										PFT	PPT	
***** Changes From FY2022 Conference Committee To FY2022 Authorized *****												
FY2022 Conference Committee												
	ConfCom	299.3	261.0	19.8	15.5	3.0	0.0	0.0	0.0	1	0	0
1004 Gen Fund		279.3										
1005 GF/Prgm		10.0										
1007 I/A Rcpts		10.0										
Outside Counsel and Expertise to Support Statehood Defense Sec20c Ch1 SSSLA2021 P117 L29 (HB69) (FY21-FY25)												
	CarryFwd	4,000.0	0.0	0.0	4,000.0	0.0	0.0	0.0	0.0	0	0	0
1004 Gen Fund		4,000.0										
Multi-year funding to provide legal services related to defense of Alaska's rights provided at statehood to develop and protect the state's natural resources, and to manage its fish and wildlife resources.												
Department of Law may use outside legal counsel, retained experts, and consultants in addition to the Department's own attorneys and staff to represent the state in asserting the state's right to develop, manage and protect all the state's natural resources. Whenever possible, the Department strives to utilize internal resources in order to achieve the greatest value for representation of the state in these matters.												
This multi-year appropriation begins July 1, 2021 and extends through June 30, 2025.												
The sum of \$4,000,000 is appropriated from the general fund to the Department of Law, Civil Division, for litigation relating to defense of rights to develop and protect the state's natural resources, to access land, and to manage its fish and wildlife resources for the fiscal years ending June 30, 2021, June 30, 2022, June 30, 2023, June 30, 2024, and June 30, 2025.												
Subtotal		4,299.3	261.0	19.8	4,015.5	3.0	0.0	0.0	0.0	1	0	0
***** Changes From FY2022 Authorized To FY2022 Management Plan *****												
Transfer Authority to Services for Anticipated Expenditures												
	LIT	0.0	-28.0	0.0	28.0	0.0	0.0	0.0	0.0	0	0	0
Transfer authority to the services line from the personal services line for anticipated costs. The remaining personal services authority is anticipated to be sufficient to cover operating expenditures.												
Subtotal		4,299.3	233.0	19.8	4,043.5	3.0	0.0	0.0	0.0	1	0	0
***** Changes From FY2022 Management Plan To FY2023 Governor *****												
Reverse Outside Counsel and Expertise to Support Statehood Defense Sec20c Ch1 SSSLA2021 P117 L29 (HB69) (FY21-FY25)												
	OTI	-4,000.0	0.0	0.0	-4,000.0	0.0	0.0	0.0	0.0	0	0	0
1004 Gen Fund		-4,000.0										
Reverse FY2022 language appropriation.												

Change Record Detail - Multiple Scenarios with Descriptions
Department of Law

Component: Deputy Attorney General's Office (2205)
RDU: Civil Division (Excludes Janus) (35)

Scenario/Change Record Title	Trans Type	Totals	Personal Services	Travel	Services	Commodities	Capital Outlay	Grants, Benefits	Miscellaneous	Positions		NP
										PFT	PPT	
FY2023 Executive Health Insurance, SBS, and Risk Management Rate Changes												
1004 Gen Fund	SalAdj	2.2	2.2	0.0	0.0	0.0	0.0	0.0	0.0	0	0	0
FY2023 Change Partially Exempt & Exempt Executive (EE) - Health Insurance from \$1,555 to \$1,685; SBS and Risk Management Rates: \$2.2												
FY2023 PERS Actuarial Rate Adjustment to 24.79% Ch9 SLA2021 (SB55)												
1004 Gen Fund	SalAdj	-8.1	-8.1	0.0	0.0	0.0	0.0	0.0	0.0	0	0	0
Includes: FY2023 Adjustment for PERS ARM Board Approved Rate of 24.79% (from 30.11%): \$-8.1												
Outside Counsel and Expertise to Support Statehood Defense (FY23-FY25)												
1004 Gen Fund	MultiYr	4,000.0	0.0	0.0	4,000.0	0.0	0.0	0.0	0.0	0	0	0
Multi-year funding to provide legal services related to defense of Alaska's rights provided at statehood to develop and protect the state's natural resources, to manage its fish and wildlife resources, and to protect state sovereignty.												
The Department of Law may use outside legal counsel, retained experts, and consultants in addition to the Department's own attorneys and staff to represent the state in protecting the state's sovereignty. Whenever possible, the Department strives to utilize internal resources in order to achieve the greatest value for representation of the state in these matters.												
*The sum of \$4,000,000 is appropriated from the general fund to the Department of Law, Civil Division, for litigation relating to defense of rights to develop and protect the state's natural resources, to access land, to manage its fish and wildlife resources, and to protect state sovereignty in the fiscal years ending June 30, 2023, June 30, 2024, and June 30, 2025.												
Add Carryforward Language for Civil Division												
	Misadj	0.0	0.0	0.0	0.0	0.0	0.0	0.0	0.0	0	0	0
Add language in numbers section for the Civil Division appropriation:												
The amount appropriated by this appropriation includes the unexpended and unobligated balance on June 30, 2022, of inter-agency receipts collected through the Department of Law's federally approved cost allocation plan.												
Totals		4,293.4	227.1	19.8	4,043.5	3.0	0.0	0.0	0.0	1	0	0

Line Item Detail (1676)
Department of Law
Travel

Component: Deputy Attorney General's Office (2205)

Line Number	Line Name		FY2021 Actuals	FY2022 Management Plan	FY2023 Governor
2000	Travel		0.4	19.8	19.8
Object Class	Servicing Agency	Explanation	FY2021 Actuals	FY2022 Management Plan	FY2023 Governor
2000 Travel Detail Totals			0.4	19.8	19.8
2000	In-State Employee Travel	Travel for attorneys to interview witnesses and attend court proceedings, as well as for necessary training for both attorneys and paraprofessionals. Includes travel for management purposes.	0.2	15.0	15.0
2001	In-State Non-Employee Travel	Travel costs for witnesses to testify in court.	0.1	0.5	0.5
2002	Out of State Employee Travel	Travel costs and expenses for out-of-state travel for conferences, training, etc.	0.1	3.8	3.8
2003	Out of State Non-Employee Travel	Travel costs and expenses for out-of-state witnesses to testify in court.	0.0	0.5	0.5

Line Item Detail (1676)
Department of Law
Services

Component: Deputy Attorney General's Office (2205)

Line Number	Line Name		FY2021 Actuals	FY2022 Management Plan	FY2023 Governor
3000	Services		350.3	4,043.5	4,043.5
Object Class	Servicing Agency	Explanation	FY2021 Actuals	FY2022 Management Plan	FY2023 Governor
3000 Services Detail Totals			350.3	4,043.5	4,043.5
3000	Education Services	Conferences, training and memberships.	4.6	5.0	5.0
3001	Financial Services	Bankcard service fees.	0.1	0.5	0.5
3002	Legal and Judicial Services	Depositions, research costs, expert witness and consultant fees.	2.8	0.0	0.0
3003	Information Technology	Training, consulting and software licensing and maintenance. Annual maintenance fee for mission-critical information management systems.	203.7	0.0	0.0
3004	Telecommunications	Local telephone service, long distance charges and cellular phone services paid to third-party telephone utilities.	32.0	0.0	0.0
3006	Delivery Services	Freight, courier, postage, and transportation of trial exhibit materials.	99.8	5.0	5.0
3007	Advertising and Promotions	Publication of legal notices.	6.2	0.0	0.0
3008	Utilities	Waste management disposal costs not included in lease.	18.2	0.0	0.0
3009	Structure/Infrastructure/Land	Rentals/leases - records and evidence storage.	118.7	0.0	0.0
3010	Equipment/Machinery	Office equipment rental - copier and postage meters.	3.9	0.0	0.0
3011	Other Services	Cost transfers and miscellaneous items within the services line (commissions, etc.).	-6,605.4	4,000.0	4,000.0

Line Item Detail (1676)
Department of Law
Services

Component: Deputy Attorney General's Office (2205)

Object Class		Servicing Agency	Explanation	FY2021 Actuals	FY2022 Management Plan	FY2023 Governor
3000 Services Detail Totals				350.3	4,043.5	4,043.5
3013	Inter-Agency Data Processing Operations Allocation	Law - Administrative Services (2164)	RSA Law, Information services, data processing investments and support.	90.9	0.0	0.0
3017	Inter-Agency Information Technology Non-Telecommunications	Admin - Department-wide	RSA Administration, Office of Information Technology computer services.	970.9	2.5	2.5
3018	Inter-Agency Information Technology Telecommunications	Admin - Department-wide	RSA Administration, Office of Information Technology telecommunications services.	127.4	2.5	2.5
3021	Inter-Agency Mail		RSA Administration, Central Mail.	13.2	0.0	0.0
3022	Inter-Agency Human Resources	Law - Administrative Services (2164)	RSA Law, Human Resources position.	219.9	0.0	0.0
3023	Inter-Agency Building Leases	Admin - Department-wide	Leased office space managed by General Services.	1,649.1	13.0	13.0
3026	Inter-Agency Insurance		RSA Administration, Risk Management.	16.1	0.0	0.0
3027	Inter-Agency Financial		RSA Administration, Finance Chargeback (IRIS).	41.0	0.0	0.0
3028	Inter-Agency Americans with Disabilities Act Compliance		RSA Administration - Division of Personnel and Labor Relations, Americans with Disabilities Act.	2.1	0.0	0.0
3038	Inter-Agency Management/Consulting	Law - Administrative Services (2164)	RSA Law, Information services, project and management support.	800.0	5.0	5.0
3038	Inter-Agency Management/Consulting	Law - Information and Project Support (2258)	RSA Law, Information services, project and management support.	2,062.6	5.0	5.0
3038	Inter-Agency Management/Consulting	Law - Office of the Attorney General (2162)	RSA Law, Information services, project and management support.	472.5	5.0	5.0

Line Item Detail (1676)
Department of Law
Commodities

Component: Deputy Attorney General's Office (2205)

Line Number	Line Name		FY2021 Actuals	FY2022 Management Plan	FY2023 Governor
4000	Commodities		134.4	3.0	3.0
Object Class	Servicing Agency	Explanation	FY2021 Actuals	FY2022 Management Plan	FY2023 Governor
4000 Commodities Detail Totals			134.4	3.0	3.0
4000	Business	Reference materials and subscriptions, including statutes, software applications, non-capital desktop refresh, and miscellaneous office supplies.	133.2	3.0	3.0
4002	Household/Institutional	Institutional supplies for cleaning and maintenance.	0.6	0.0	0.0
4004	Safety	Safety and security purchases.	0.6	0.0	0.0

Line Item Detail (1676)
Department of Law
Capital Outlay

Component: Deputy Attorney General's Office (2205)

Line Number	Line Name		FY2021 Actuals	FY2022 Management Plan	FY2023 Governor
5000	Capital Outlay		0.1	0.0	0.0
Object Class	Servicing Agency	Explanation	FY2021 Actuals	FY2022 Management Plan	FY2023 Governor
5000 Capital Outlay Detail Totals			0.1	0.0	0.0
5004	Equipment	Equipment purchases.	0.1	0.0	0.0

Revenue Detail (1681)
Department of Law

Component: Deputy Attorney General's Office (2205)

Revenue Type (OMB Fund Code) Revenue Source	Component	Comment	FY2021 Actuals	FY2022 Management Plan	FY2023 Governor
5005 GF/Prgm (1005 GF/Prgm)			0.0	10.0	10.0
5119 Program Receipts Law - Charges for Services		Discovery receipts - receipts from private attorneys.	0.0	10.0	10.0
5007 I/A Rcpts (1007 I/A Rcpts)			0.0	10.0	10.0
5301 Inter-Agency Receipts	Law - Criminal Justice Litigation (2202)	RSA Law, Criminal Justice Litigation - legal services support for criminal matters related to civil litigation.	0.0	10.0	10.0
6004 Gen Fund (1004 Gen Fund)			0.9	0.0	0.0
6046 General Fund - Prior Year Reimbursement Recovery		Prior year recovery	0.9	0.0	0.0

Inter-Agency Services (1682)
Department of Law

Component: Deputy Attorney General's Office (2205)

			FY2021 Actuals	FY2022 Management Plan	FY2023 Governor	
Component Totals			6,393.3	33.0	33.0	
With Department of Law			3,645.9	15.0	15.0	
With Department of Administration			2,747.4	18.0	18.0	
Object Class	Servicing Agency	Explanation	FY2021 Actuals	FY2022 Management Plan	FY2023 Governor	
3013	Inter-Agency Data Processing Operations Allocation	Law - Administrative Services (2164)	RSA Law, Information services, data processing investments and support.	90.9	0.0	0.0
3017	Inter-Agency Information Technology Non-Telecommunications	Admin - Department-wide	RSA Administration, Office of Information Technology computer services.	970.9	2.5	2.5
3018	Inter-Agency Information Technology Telecommunications	Admin - Department-wide	RSA Administration, Office of Information Technology telecommunications services.	127.4	2.5	2.5
3022	Inter-Agency Human Resources	Law - Administrative Services (2164)	RSA Law, Human Resources position.	219.9	0.0	0.0
3023	Inter-Agency Building Leases	Admin - Department-wide	Leased office space managed by General Services.	1,649.1	13.0	13.0
3038	Inter-Agency Management/Consulting	Law - Administrative Services (2164)	RSA Law, Information services, project and management support.	800.0	5.0	5.0
3038	Inter-Agency Management/Consulting	Law - Information and Project Support (2258)	RSA Law, Information services, project and management support.	2,062.6	5.0	5.0
3038	Inter-Agency Management/Consulting	Law - Office of the Attorney General (2162)	RSA Law, Information services, project and management support.	472.5	5.0	5.0

Personal Services Expenditure Detail
Department of Law

Scenario: FY2023 Governor (18673)
Component: Deputy Attorney General's Office (2205)
RDU: Civil Division (Excludes Janus) (35)

PCN	Job Class Title	Time Status	Retire Code	Barg Unit	Location	Salary Sched	Range / Step	Comp Months	Split / Count	Annual Salaries	COLA	Premium Pay	Annual Benefits	Total Costs	UGF Amount
03-0002	Deputy Attorney General	FT	A	XE	Juneau	N05	28M / N	12.0		153,881	0	0	77,087	230,968	230,968
													Total Salary Costs:	153,881	
													Total COLA:	0	
													Total Premium Pay:	0	
													Total Benefits:	77,087	
													Total Pre-Vacancy:	230,968	
													Minus Vacancy Adjustment of 1.67%:	(3,868)	
													Total Post-Vacancy:	227,100	
													Plus Lump Sum Premium Pay:	0	
													Personal Services Line 100:	227,100	
Total Component Months:		12.0													

PCN Funding Sources:		Pre-Vacancy	Post-Vacancy	Percent
1004	General Fund Receipts	230,968	227,100	100.00%
Total PCN Funding:		230,968	227,100	100.00%

Note: If a position is split, an asterisk (*) will appear in the Split/Count column. If the split position is also counted in the component, two asterisks (**) will appear in this column. [No valid job title] appearing in the Job Class Title indicates that the PCN has an invalid class code or invalid range for the class code effective date of this scenario.

CIVIL DIVISION STRUCTURE AND DEPUTY ATTORNEY GENERAL'S OFFICE

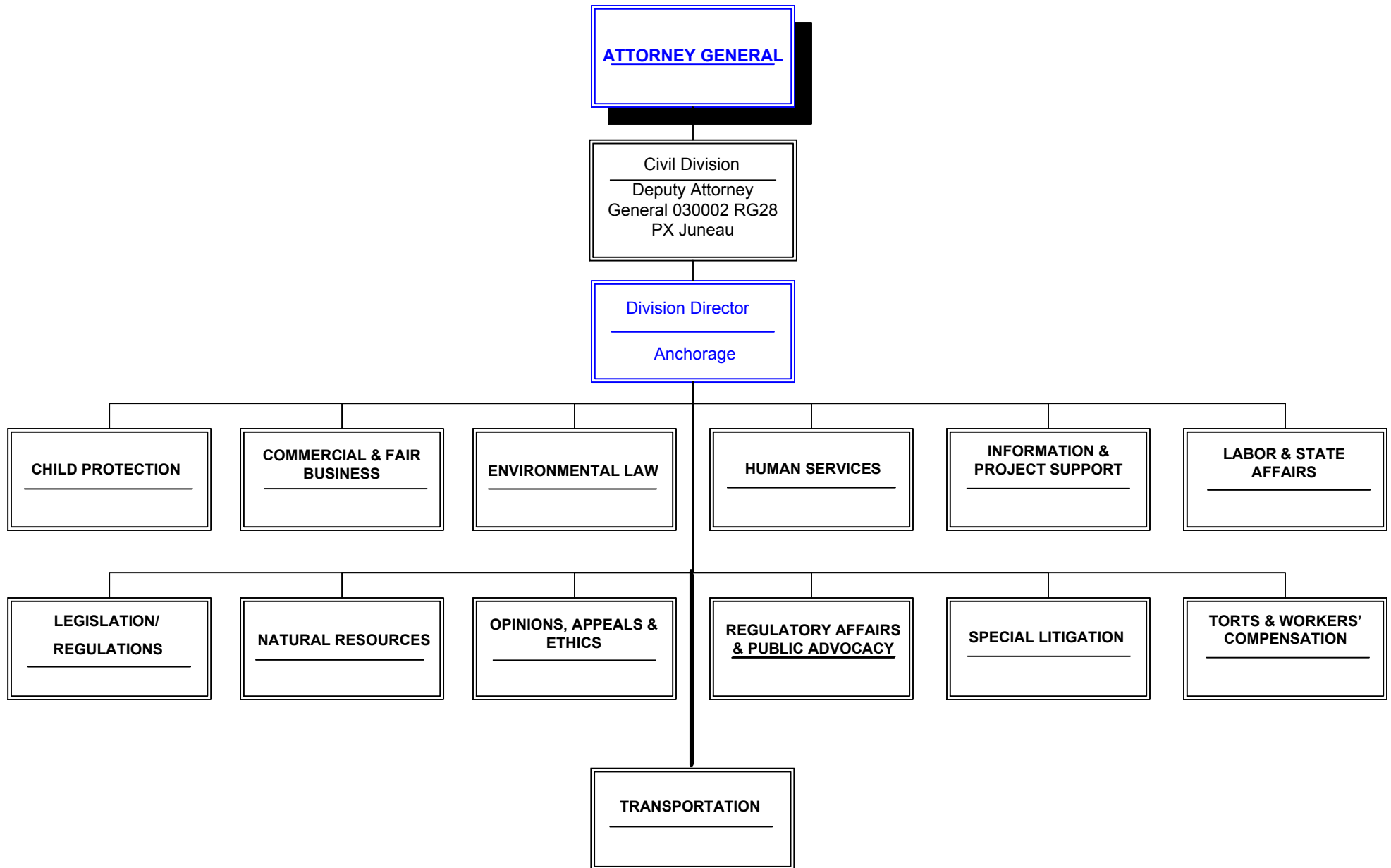

State of Alaska FY2023 Governor's Operating Budget

Department of Law Child Protection Component Budget Summary

Component: Child Protection**Contribution to Department's Mission**

The Child Protection Section provides advice and representation to the Office of Children's Services (OCS) in the Department of Health and Social Services (DHSS) to assist that department in the performance of its functions.

Core Services

- Child Protection attorneys provide legal assistance to OCS on issues arising from the state's child protection system. Attorneys advise OCS social workers prior to initiation of legal action to remove children from abusive or neglectful homes and, if necessary, litigate whether children should be in the legal custody of the state.
- Child Protection attorneys help OCS implement plans to safely return children home and if necessary take legal action to terminate parental rights, allowing the children to be placed in adoptive or other permanent homes.

Major Component Accomplishments in 2021

- Section members managed very substantial Child-In-Need-of-Aid (CINA) caseloads while working to improve the child protection system and foster state-tribal relations to better protect children. The section primarily litigates cases at the trial court level with 25 attorneys to handle approximately 3,100 individual CINA cases.
- The section continued to work with the Child Support Services Division in the Department of Revenue to establish paternity early in child protection cases and to obtain child support orders from parents whose children are in state custody.
- The section worked with OCS to establish procedures to ensure timely compliance with requirements of Title IV-E of the Social Security Act, which is an important funding stream for foster care costs.
- Section attorneys provided regular training sessions on the child protection legal system at the social worker academy and in OCS field offices.
- Certain section attorneys participated in the Court Improvement Project, the CINA Rules Committee, a statewide Indian Child Welfare Act Committee, and other groups and committees seeking to improve the child protection system.
- Section attorneys worked with OCS to help it partner with tribes and tribal organizations and to address long-standing tribal-state issues to improve child welfare.
- Section members participated in regional Multidisciplinary Teams to coordinate civil and criminal response to sexual and physical abuse cases.
- The section recouped funds from the federal government's Title IV-E program through eligible legal services.

Key Component Challenges

- Rural connectivity issues slow the functions of the division's electronic case management system (ProLaw) and, in turn, create productivity challenges for staff. These challenges were magnified with the technology needs related to COVID-19.
- Attorney turnover and depressed resources create morale and retention problems that negatively impact the section's ability to deliver client services.
- More cases and abbreviated court schedules, aggravated by COVID-19 and the need to move to virtual hearings, lead to longer stays in foster care for children who could otherwise find permanency in their "forever home" and

increases the burden of cost to the state. The limited resources and growing caseloads could also negatively impact the amount of federal Title IV-E dollars granted to the state in reimbursement for eligible legal services performed in CINA cases.

Significant Changes in Results to be Delivered in FY2023

The section continues to implement consistent, uniform legal and administrative services across all seven child protection offices in the state. Emphasized areas include consistency of legal positions, administrative processes, uniform training for OCS employees, and increased use of ProLaw forms and functions.

The section will work with community stakeholders, the court and related legal offices to streamline the child welfare system, increase efficiencies and decrease resource needs.

The section will focus on maintaining staffing levels and preserving morale so that the section can continue to provide quality legal services to its clients.

Statutory and Regulatory Authority

AS 44.23.020

Contact Information
<p>Contact: Carla Erickson, Chief Assistant Attorney General Phone: (907) 269-5100 E-mail: carla.erickson@alaska.gov</p>

Child Protection Personal Services Information				
Authorized Positions			Personal Services Costs	
	<u>FY2022</u> <u>Management</u> <u>Plan</u>	<u>FY2023</u> <u>Governor</u>		
Full-time	56	56	Annual Salaries	4,495,238
Part-time	0	0	COLA	2,329
Nonpermanent	0	0	Premium Pay	0
			Annual Benefits	2,770,879
			<i>Less 6.52% Vacancy Factor</i>	<i>(473,946)</i>
			Lump Sum Premium Pay	0
Totals	56	56	Total Personal Services	6,794,500

Position Classification Summary					
Job Class Title	Anchorage	Fairbanks	Juneau	Others	Total
Associate Attorney 1	0	1	0	0	1
Associate Attorney 2	1	0	0	0	1
Attorney 3	4	0	0	1	5
Attorney 4	7	3	2	5	17
Attorney 5	2	0	0	1	3
Attorney 6	1	0	0	0	1
Law Office Assistant 1	9	1	1	3	14
Law Office Assistant 2	1	1	0	0	2
Paralegal 1	2	1	0	0	3
Paralegal 2	4	1	1	3	9
Totals	31	8	4	13	56

Component Detail All Funds
Department of Law

Component: Child Protection (2961)
RDU: Civil Division (Excludes Janus) (35)

Non-Formula Component

	FY2021 Actuals	FY2022 Conference Committee	FY2022 Authorized	FY2022 Management Plan	FY2023 Governor	FY2022 Management Plan vs FY2023 Governor	
71000 Personal Services	7,862.0	7,012.6	7,012.6	6,962.6	6,794.5	-168.1	-2.4%
72000 Travel	19.4	52.0	52.0	52.0	52.0	0.0	0.0%
73000 Services	1,759.6	700.1	700.1	700.1	700.1	0.0	0.0%
74000 Commodities	90.9	98.9	98.9	98.9	98.9	0.0	0.0%
75000 Capital Outlay	31.5	0.0	0.0	0.0	0.0	0.0	0.0%
77000 Grants, Benefits	0.0	0.0	0.0	0.0	0.0	0.0	0.0%
78000 Miscellaneous	0.0	0.0	0.0	0.0	0.0	0.0	0.0%
Totals	9,763.4	7,863.6	7,863.6	7,813.6	7,645.5	-168.1	-2.2%
Fund Sources:							
1004 Gen Fund (UGF)	6,083.5	5,568.5	5,568.5	5,568.5	5,381.1	-187.4	-3.4%
1007 I/A Rcpts (Other)	3,679.9	2,295.1	2,295.1	2,245.1	2,264.4	19.3	0.9%
Unrestricted General (UGF)	6,083.5	5,568.5	5,568.5	5,568.5	5,381.1	-187.4	-3.4%
Designated General (DGF)	0.0	0.0	0.0	0.0	0.0	0.0	0.0%
Other Funds	3,679.9	2,295.1	2,295.1	2,245.1	2,264.4	19.3	0.9%
Federal Funds	0.0	0.0	0.0	0.0	0.0	0.0	0.0%
Positions:							
Permanent Full Time	56	56	56	56	56	0	0.0%
Permanent Part Time	0	0	0	0	0	0	0.0%
Non Permanent	0	0	0	0	0	0	0.0%

Change Record Detail - Multiple Scenarios with Descriptions
Department of Law

Component: Child Protection (2961)
RDU: Civil Division (Excludes Janus) (35)

Scenario/Change Record Title	Trans Type	Totals	Personal Services	Travel	Services	Commodities	Capital Outlay	Grants, Benefits	Miscellaneous	Positions		NP
										PFT	PPT	
***** Changes From FY2022 Conference Committee To FY2022 Authorized *****												
FY2022 Conference Committee												
	ConfCom	7,863.6	7,012.6	52.0	700.1	98.9	0.0	0.0	0.0	56	0	0
1004 Gen Fund		5,568.5										
1007 I/A Rcpts		2,295.1										
Subtotal		7,863.6	7,012.6	52.0	700.1	98.9	0.0	0.0	0.0	56	0	0
***** Changes From FY2022 Authorized To FY2022 Management Plan *****												
Transfer Attorney 4 (03-0195) from Environmental Law for Required Legal Expertise												
	Trin	0.0	0.0	0.0	0.0	0.0	0.0	0.0	0.0	1	0	0
Transfer one full-time Attorney 4 position (03-0195), range 24, located in Anchorage, from the Environmental Law component to the Child Protection component to keep pace with the required level of legal expertise needed within the office. The remaining staff in Environmental Law are sufficient to accommodate anticipated workload.												
Transfer Attorney 5 (03-0413) to Opinions, Appeals and Ethics for Required Legal Expertise												
	Trout	-50.0	-50.0	0.0	0.0	0.0	0.0	0.0	0.0	-1	0	0
1007 I/A Rcpts		-50.0										
Transfer one full-time Attorney 5 position (03-0413), range 25, located in Anchorage, to the Opinions, Appeals and Ethics component from the Child Protection component to keep pace with the required level of legal expertise needed within the office. The remaining staff in Child Protection are sufficient to accommodate anticipated workload.												
Subtotal		7,813.6	6,962.6	52.0	700.1	98.9	0.0	0.0	0.0	56	0	0
***** Changes From FY2022 Management Plan To FY2023 Governor *****												
FY2023 Salary and Benefit Adjustments												
	SalAdj	1.4	1.4	0.0	0.0	0.0	0.0	0.0	0.0	0	0	0
1004 Gen Fund		1.4										
FY2023 SU BU - Supervisory Employees (SS) 1% COLA: \$1.4												
FY2023 Executive Health Insurance, SBS, and Risk Management Rate Changes												
	SalAdj	49.9	49.9	0.0	0.0	0.0	0.0	0.0	0.0	0	0	0
1004 Gen Fund		32.5										
1007 I/A Rcpts		17.4										
FY2023 Change Partially Exempt & Exempt Executive (EE) - Health Insurance from \$1,555 to \$1,685; SBS and Risk Management Rates: \$49.9												
FY2023 Supervisory Employees Health Insurance, SBS, and Risk Management Rate Changes												

Change Record Detail - Multiple Scenarios with Descriptions
Department of Law

Component: Child Protection (2961)
RDU: Civil Division (Excludes Janus) (35)

Scenario/Change Record Title	Trans Type	Totals	Personal Services	Travel	Services	Commodities	Capital Outlay	Grants, Benefits	Miscellaneous	Positions		NP
										PFT	PPT	
	SalAdj	4.9	4.9	0.0	0.0	0.0	0.0	0.0	0.0	0	0	0
1004 Gen Fund		3.2										
1007 I/A Rcpts		1.7										
FY2023 Change Supervisory Employees (SS) - Health Insurance from \$1,555 to \$1,685; SBS and Risk Management Rates: \$4.9												
FY2023 General Government Unit SBS and Risk Management Rate Changes												
	SalAdj	3.4	3.4	0.0	0.0	0.0	0.0	0.0	0.0	0	0	0
1004 Gen Fund		3.2										
1007 I/A Rcpts		0.2										
FY2023 Change General Government Unit (GG, GP, GY, GZ) - SBS, and Risk Management Rates: \$3.4												
FY2023 PERS Actuarial Rate Adjustment to 24.79% Ch9 SLA2021 (SB55)												
	SalAdj	-227.7	-227.7	0.0	0.0	0.0	0.0	0.0	0.0	0	0	0
1004 Gen Fund		-165.0										
1007 I/A Rcpts		-62.7										
Includes: FY2023 Adjustment for PERS ARM Board Approved Rate of 24.79% (from 30.11%): \$-227.7												
Realign PERS Rate Adjustment by Fund Source Ch9 SLA2021 (SB55)												
	FndChg	0.0	0.0	0.0	0.0	0.0	0.0	0.0	0.0	0	0	0
1004 Gen Fund		-62.7										
1007 I/A Rcpts		62.7										
Remove one-time UGF subsidy for rate agency assigned in SB55 fiscal note (Ch 9 SLA 2021).												
Totals		7,645.5	6,794.5	52.0	700.1	98.9	0.0	0.0	0.0	56	0	0

Line Item Detail (1676)
Department of Law
Travel

Component: Child Protection (2961)

Line Number	Line Name		FY2021 Actuals	FY2022 Management Plan	FY2023 Governor
2000	Travel		19.4	52.0	52.0
Object Class	Servicing Agency	Explanation	FY2021 Actuals	FY2022 Management Plan	FY2023 Governor
2000 Travel Detail Totals			19.4	52.0	52.0
2000	In-State Employee Travel	Travel for attorneys to interview witnesses and attend court proceedings, as well as for necessary training for both attorneys and paraprofessionals. Includes travel for management purposes.	1.8	32.0	32.0
2001	In-State Non-Employee Travel	Travel costs for witnesses to testify in court.	0.0	7.0	7.0
2002	Out of State Employee Travel	Travel costs and expenses for out-of-state travel for conferences, training, etc.	0.0	4.0	4.0
2006	Other Travel Costs	Travel cost transfers.	17.6	9.0	9.0

Line Item Detail (1676)
Department of Law
Services

Component: Child Protection (2961)

Line Number	Line Name		FY2021 Actuals	FY2022 Management Plan	FY2023 Governor
3000	Services		1,759.6	700.1	700.1
Object Class	Servicing Agency	Explanation	FY2021 Actuals	FY2022 Management Plan	FY2023 Governor
3000 Services Detail Totals			1,759.6	700.1	700.1
3000	Education Services	Conferences, training and memberships.	15.2	15.5	15.5
3002	Legal and Judicial Services	Depositions, research costs, expert witness and consultant fees.	430.1	259.1	259.1
3003	Information Technology	Training, consulting and software licensing and maintenance. Annual maintenance fee for mission-critical information management systems.	9.5	9.5	9.5
3006	Delivery Services	Freight, courier, postage, and transportation of trial exhibit materials.	16.0	16.0	16.0
3008	Utilities	Waste management disposal costs not included in lease.	0.0	0.5	0.5
3011	Other Services	Cost transfers and miscellaneous items within the services line (commissions, etc.).	1,288.8	399.5	399.5

Line Item Detail (1676)
Department of Law
Commodities

Component: Child Protection (2961)

Line Number	Line Name		FY2021 Actuals	FY2022 Management Plan	FY2023 Governor
4000	Commodities		90.9	98.9	98.9
Object Class	Servicing Agency	Explanation	FY2021 Actuals	FY2022 Management Plan	FY2023 Governor
4000 Commodities Detail Totals			90.9	98.9	98.9
4000	Business	Reference materials and subscriptions, including statutes, software applications, non-capital desktop refresh, and miscellaneous office supplies.	0.0	0.9	0.9
4022	Commodity Transfer	Commodity cost transfers.	90.9	98.0	98.0

Line Item Detail (1676)

**Department of Law
Capital Outlay**

Component: Child Protection (2961)

Line Number	Line Name		FY2021 Actuals	FY2022 Management Plan	FY2023 Governor
5000	Capital Outlay		31.5	0.0	0.0
Object Class	Servicing Agency	Explanation	FY2021 Actuals	FY2022 Management Plan	FY2023 Governor
5000 Capital Outlay Detail Totals			31.5	0.0	0.0
5009	Capital Outlay Transfer	Capital cost transfers.	31.5	0.0	0.0

Revenue Detail (1681)
Department of Law

Component: Child Protection (2961)

Revenue Type (OMB Fund Code) Revenue Source	Component	Comment	FY2021 Actuals	FY2022 Management Plan	FY2023 Governor
5007 I/A Rcpts (1007 I/A Rcpts)			3,679.9	2,245.1	2,264.4
5301 Inter-Agency Receipts	Health - Department-wide	RSA Health and Social Services, Family Preservation - legal services provided to H&SS under Title IV-E. Program code: CV03206518.	3,207.9	1,934.9	1,938.4
5301 Inter-Agency Receipts	Health - Department-wide	RSA Health and Social Services, Child Protection - legal services provided to Family Preservation Services for assisting in the focus on permanent homes for Alaskan children. Program code: CV03206567.	8.2	8.5	8.5
5301 Inter-Agency Receipts	Health - Department-wide	RSA Health and Social Services, Child Protection - direct costs for legal services such as travel, expert witnesses and examining physicians. Program code: CV03206568.	446.3	300.0	300.0
5301 Inter-Agency Receipts	Health - Department-wide	RSA Health and Social Services, Foster Care Special Need - tribal discovery charges reimbursement. Program code: CV03206588.	17.5	1.7	17.5

Personal Services Expenditure Detail
Department of Law

Scenario: FY2023 Governor (18673)
Component: Child Protection (2961)
RDU: Civil Division (Excludes Janus) (35)

PCN	Job Class Title	Time Status	Retire Code	Barg Unit	Location	Salary Sched	Range / Step	Comp Months	Split / Count	Annual Salaries	COLA	Premium Pay	Annual Benefits	Total Costs	UGF Amount
03-0014	Law Office Assistant 2	FT	A	SS	Fairbanks	203	13O	12.0		67,134	921	0	45,375	113,430	0
03-0031	Attorney 4	FT	A	XE	Palmer	N00	24L / M	12.0		119,869	0	0	64,865	184,734	184,734
03-0034	Law Office Assistant 1	FT	A	GP	Anchorage	200	11C / D	12.0		41,282	0	0	34,151	75,433	75,433
03-0040	Attorney 4	FT	A	XE	Anchorage	N00	24L	12.0		117,176	0	0	63,862	181,038	135,779
03-0041	Attorney 4	FT	A	XE	Anchorage	N00	24F	12.0		106,451	0	0	59,869	166,320	0
03-0046	Attorney 4	FT	A	XE	Fairbanks	N03	24C / D	12.0		100,641	0	0	57,706	158,347	0
03-0073	Law Office Assistant 1	FT	A	GP	Anchorage	200	11B / C	12.0		39,685	0	0	33,556	73,241	73,241
03-0091	Law Office Assistant 1	FT	A	GP	Fairbanks	203	11D / E	12.0		43,004	0	0	34,792	77,796	0
03-0095	Law Office Assistant 2	FT	A	SS	Anchorage	600	13E / F	12.0		53,443	733	0	40,278	94,454	94,454
03-0114	Law Office Assistant 1	FT	A	GP	Anchorage	200	11C / D	12.0		40,718	0	0	33,941	74,659	0
03-0125	Law Office Assistant 1	FT	A	GP	Juneau	205	11B / C	12.0		42,062	0	0	34,441	76,503	76,503
03-0128	Attorney 4	FT	A	XE	Fairbanks	N03	24K	12.0		116,883	0	0	63,753	180,636	180,636
03-0153	Paralegal 1	FT	A	GP	Anchorage	200	14C / D	12.0		48,748	0	0	36,930	85,678	85,678
03-0154	Attorney 6	FT	A	XE	Anchorage	99	26M / N	12.0		136,736	0	0	71,144	207,880	207,880
03-0155	Attorney 3	FT	A	XE	Anchorage	N00	22E / F	12.0		92,367	0	0	54,626	146,993	146,993
03-0159	Paralegal 2	FT	A	GP	Anchorage	200	16E / F	12.0		61,576	0	0	41,706	103,282	103,282
03-0172	Attorney 4	FT	A	XE	Juneau	N05	24F / J	12.0		113,285	0	0	62,413	175,698	0
03-0175	Law Office Assistant 1	FT	A	GP	Anchorage	200	11B / C	12.0		39,516	0	0	33,493	73,009	73,009
03-0178	Paralegal 2	FT	A	GP	Juneau	205	16G / J	12.0		68,679	0	0	44,351	113,030	113,030
03-0188	Paralegal 1	FT	A	GP	Anchorage	200	14B / C	12.0		48,554	0	0	36,858	85,412	85,412
03-0189	Attorney 4	FT	A	XE	Kenai	N00	24F	12.0		106,451	0	0	59,869	166,320	0
03-0192	Law Office Assistant 1	FT	A	GP	Anchorage	200	11C / D	12.0		40,473	0	0	33,849	74,322	74,322
03-0195	Attorney 4	FT	A	XE	Anchorage	N00	24F	12.0		106,451	0	0	59,869	166,320	41,580
03-0202	Law Office Assistant 1	FT	A	GP	Anchorage	99	11N / O	12.0		50,255	0	0	37,491	87,746	87,746
03-0212	Attorney 3	FT	A	XE	Anchorage	N00	22E / F	12.0		91,991	0	0	54,486	146,477	21,972
03-0223	Attorney 4	FT	A	XE	Anchorage	N00	24D / E	12.0		102,289	0	0	58,319	160,608	160,608
03-0239	Associate Attorney 1	FT	A	XE	Fairbanks	N03	17M / N	12.0		80,204	0	0	50,097	130,301	130,301
03-0251	Attorney 5	FT	A	XE	Palmer	N00	25M	12.0		130,026	0	0	68,646	198,672	39,734
03-0262	Attorney 4	FT	A	XE	Anchorage	N00	24F / J	12.0		109,039	0	0	60,833	169,872	0
03-0311	Law Office Assistant 1	FT	A	GP	Anchorage	200	11F / G	12.0		44,428	0	0	35,322	79,750	79,750
03-0348	Attorney 4	FT	A	XE	Juneau	N05	24E / F	12.0		110,862	0	0	61,511	172,373	172,373
03-0351	Paralegal 2	FT	A	GP	Anchorage	99	16N / O	12.0		77,127	0	0	47,496	124,623	124,623
03-0353	Law Office Assistant 1	FT	A	GP	Anchorage	200	11B / C	12.0		39,733	0	0	33,574	73,307	73,307
03-0354	Attorney 4	FT	A	XE	Fairbanks	N03	24J	12.0		113,217	0	0	62,388	175,605	175,605
03-0355	Attorney 3	FT	A	XE	Anchorage	N00	22C / D	12.0		86,018	0	0	52,262	138,280	138,280
03-0356	Paralegal 2	FT	A	GP	Anchorage	200	16D / E	12.0		58,730	0	0	40,647	99,377	99,377
03-0358	Attorney 3	FT	A	XE	Anchorage	N00	22F	12.0		92,957	0	0	54,845	147,802	147,802
03-0359	Law Office Assistant 1	FT	A	GP	Anchorage	200	11C / D	12.0		41,077	0	0	34,074	75,151	75,151

Note: If a position is split, an asterisk (*) will appear in the Split/Count column. If the split position is also counted in the component, two asterisks (**) will appear in this column. [No valid job title] appearing in the Job Class Title indicates that the PCN has an invalid class code or invalid range for the class code effective date of this scenario.

Personal Services Expenditure Detail
Department of Law

Scenario: FY2023 Governor (18673)
Component: Child Protection (2961)
RDU: Civil Division (Excludes Janus) (35)

PCN	Job Class Title	Time Status	Retire Code	Barg Unit	Location	Salary Sched	Range / Step	Comp Months	Split / Count	Annual Salaries	COLA	Premium Pay	Annual Benefits	Total Costs	UGF Amount
03-0362	Attorney 4	FT	A	XE	Anchorage	N00	24C	12.0		96,057	0	0	55,999	152,056	0
03-0382	Attorney 4	FT	A	XE	Anchorage	N00	24J	12.0		109,902	0	0	61,154	171,056	171,056
03-0383	Attorney 3	FT	A	XE	Palmer	N00	22F	12.0		92,957	0	0	54,845	147,802	147,802
03-0388	Attorney 4	FT	A	XE	Kenai	N00	24E / F	12.0		104,860	0	0	59,277	164,137	164,137
03-0389	Paralegal 2	FT	A	GP	Fairbanks	203	16B / C	12.0		56,017	0	0	39,636	95,653	95,653
03-0390	Attorney 4	FT	A	XE	Bethel	N50	24C / D	12.0		147,020	0	0	74,953	221,973	0
03-0393	Attorney 4	FT	A	XE	Palmer	N00	24F / J	12.0		107,026	0	0	60,083	167,109	167,109
03-0400	Law Office Assistant 1	FT	A	GP	Palmer	99	11N	12.0		53,625	0	0	38,746	92,371	92,371
03-0401	Paralegal 2	FT	A	GP	Palmer	200	16D / E	12.0		59,173	0	0	40,811	99,984	99,984
03-0402	Paralegal 2	FT	A	GP	Kenai	200	16M	12.0		73,964	0	0	46,318	120,282	120,282
03-0406	Associate Attorney 2	FT	A	XE	Anchorage	N00	19J / K	12.0		80,792	0	0	50,316	131,108	131,108
03-0407	Attorney 5	FT	A	XE	Anchorage	99	25P	12.0		145,929	0	0	74,567	220,496	220,496
03-0412	Paralegal 2	FT	A	GP	Palmer	200	16D / E	12.0		58,730	0	0	40,647	99,377	99,377
03-0415	Attorney 5	FT	A	XE	Anchorage	N00	25J / K	12.0		121,012	0	0	65,290	186,302	186,302
03-0417	Law Office Assistant 1	FT	A	SS	Palmer	600	11J	12.0		49,213	675	0	38,703	88,591	88,591
03-0421	Paralegal 1	FT	A	GP	Fairbanks	203	14E / F	12.0		54,026	0	0	38,895	92,921	92,921
03-1093	Paralegal 2	FT	A	GP	Anchorage	200	16D / E	12.0		59,793	0	0	41,042	100,835	100,835
03-1304	Law Office Assistant 1	FT	A	GP	Kenai	200	11G / J	12.0		46,005	0	0	35,909	81,914	81,914

Total Positions		New	Deleted	Total Salary Costs:	4,495,238
Full Time Positions:	56	0	0	Total COLA:	2,329
Part Time Positions:	0	0	0	Total Premium Pay:	0
Non Permanent Positions:	0	0	0	Total Benefits:	2,770,879
Positions in Component:	56	0	0	Total Pre-Vacancy:	7,268,446
				Minus Vacancy Adjustment of 6.52%:	(473,946)
				Total Post-Vacancy:	6,794,500
				Plus Lump Sum Premium Pay:	0
				Personal Services Line 100:	6,794,500

PCN Funding Sources:	Pre-Vacancy	Post-Vacancy	Percent
1004 General Fund Receipts	5,338,532	4,990,428	73.45%
1007 Interagency Receipts	1,929,914	1,804,072	26.55%
Total PCN Funding:	7,268,446	6,794,500	100.00%

Note: If a position is split, an asterisk (*) will appear in the Split/Count column. If the split position is also counted in the component, two asterisks (**) will appear in this column. [No valid job title] appearing in the Job Class Title indicates that the PCN has an invalid class code or invalid range for the class code effective date of this scenario.

CIVIL DIVISION

Child Protection 1 of 2

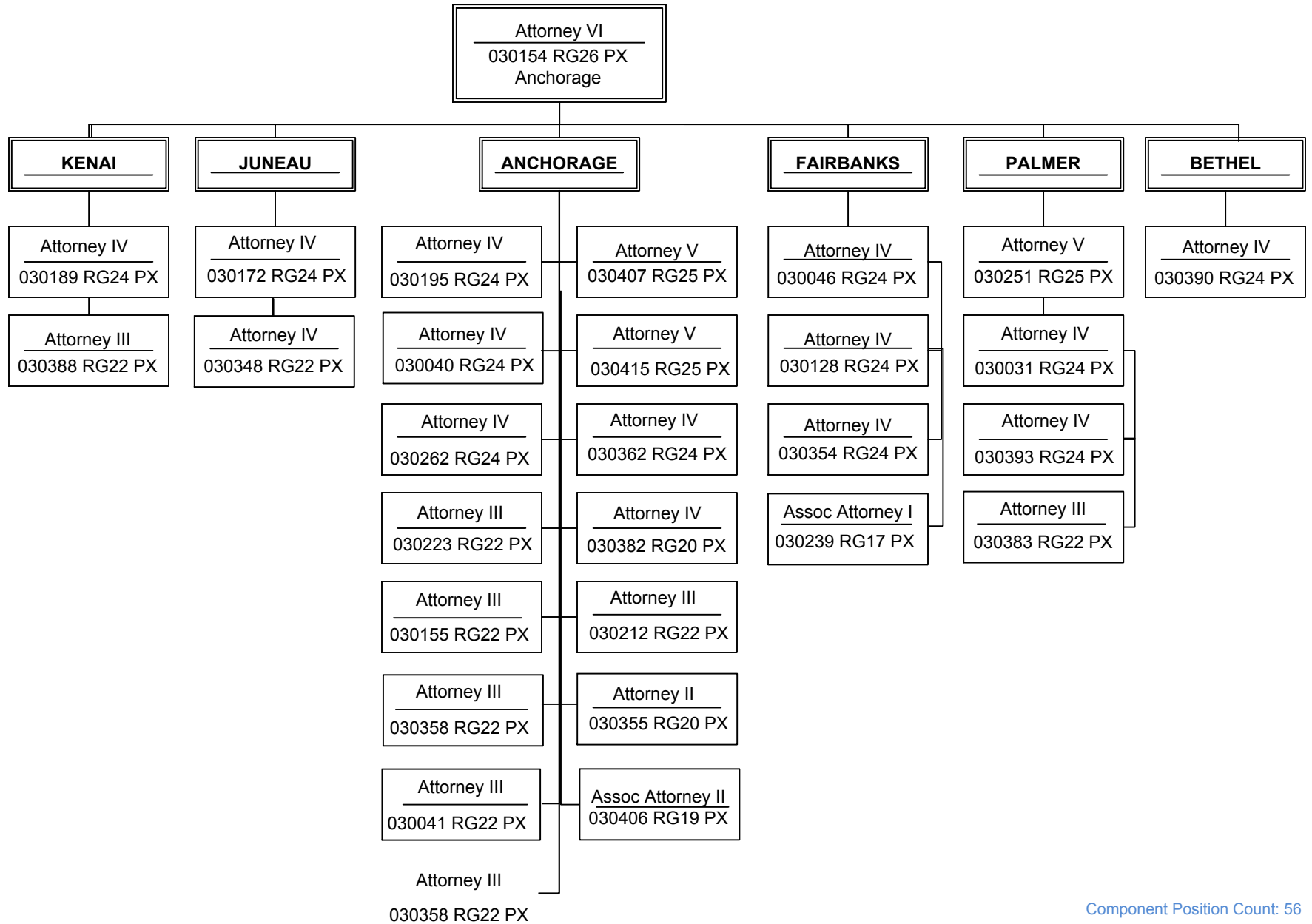

CIVIL DIVISION

Child Protection - 2 of 2

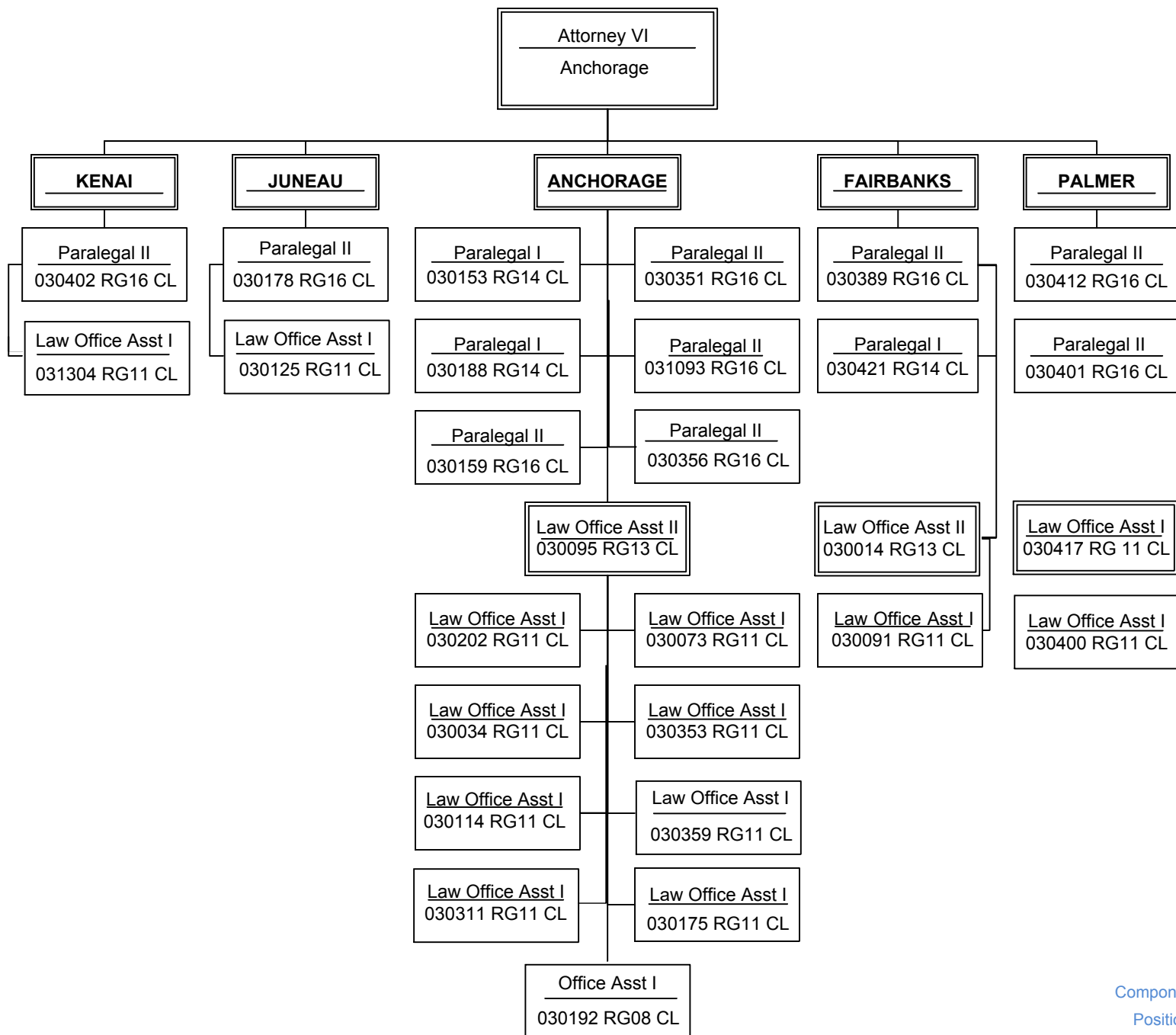

Component Position Count: 56

Position Count this page: 28

State of Alaska FY2023 Governor's Operating Budget

Department of Law Commercial and Fair Business Component Budget Summary

Component: Commercial and Fair Business**Contribution to Department's Mission**

The Commercial and Fair Business Section exercises the Attorney General's authority to protect the public by enforcing consumer protection and antitrust laws, and providing advice and representation to agencies that encourage and regulate economic activity. In FY2018, this section assumed the responsibility to help the Department of Revenue's (DOR) Child Support Services Division enforce child support orders due to the elimination of the Collections and Support section that previously performed this work. In FY2019, responsibilities for consumer protection were divided between the Commercial and Fair Business section and the Special Litigation section in order to maximize available expertise and increase the strength of the state's consumer protection function.

Core Services

- The Commercial and Fair Business section oversees registration of charitable organizations and telephone solicitors. The section also provides representation, defense, and counsel to 17 different divisions, commissions, and corporations within the Departments of Administration; Revenue; Education and Early Development; Commerce, Community, and Economic Development; Natural Resources; and to 20 professional licensing boards and commissions.
- The section works with the agencies, boards, and commissions governing professional licenses, tobacco sales, alcoholic beverages, marijuana control, certified teachers, and post-secondary education. The section provides legal services to agencies that monitor insurance companies and other insurance licensees, charitable gaming, public utilities, banks, securities, corporations, mortgage brokers, and payday lenders.
- In addition to protecting the public, the section helps protect the integrity of the state's public finances through fair interpretation, implementation, enforcement, and adoption of statutes and regulations governing state revenue and taxation, the Permanent Fund Dividend, Alaska Housing Finance Corporation, and various state lending and public housing programs.
- The section also represents DOR's Child Support Services Division in court to enforce child support orders, including proceedings to establish or disestablish paternity, establish or modify child support orders, obtain orders to garnish Native corporation dividends to benefit minor children, and obtain orders requiring parents who owe support to apply for their Permanent Fund dividends. It also represents the agency in appeals from administrative decisions to the superior court.

Major Component Accomplishments in 2021**Consumer Protection**

The section processed 366 consumer complaints. Of these, 352 were resolved through an informal complaint process, by launching a formal investigation, or referral to other appropriate state and federal agencies.

The section registered 5,228 charitable organizations and 31 paid solicitors and telemarketers, collecting more than \$215,900 in registration fees.

The section implemented an electronic registration system for charitable organizations and paid solicitors, which saved the state staff time and some costs of the registration process. The section continues to work on the electronic registration system and instructions to charities and paid solicitors to fully maximize its potential and further reduce staff time.

Agency Advice and Representation

COVID-19: The COVID-19 pandemic continues to have a significant impact on several of the section's client agencies. Attorneys in the section responded to increased requests for client assistance on very tight deadlines. The professional licensing boards within the Division of Corporations, Business, and Professional Licensing in particular needed substantial assistance with emergency regulations and advice in order to allow licensees to continue to provide services while still protecting Alaskans.

Marijuana Initiative: The section continued to provide legal advice and assistance to the Marijuana Control Board and its staff. The section's advice covered myriad issues related to licensing, enforcement, regulation, administrative litigation, and board governance. Due to the development of the marijuana industry and recent changes to the alcohol industry, and the unprecedented challenges of responding to COVID-19, both boards had a significant increase in their need for legal services.

Professional Licensing: Section attorneys successfully prosecuted or negotiated settlements in 25 professional discipline, license denial, license reinstatement, and unlicensed activity matters. These cases resulted in various actions including revocation, surrender, fines, reprimand, suspension, license conditions, or denial of a license.

Public Housing: Section attorneys assisted the Alaska Housing Finance Corporation (AHFC) as it navigated the changing eviction landscape caused by COVID-19 and related eviction moratorium. Section attorneys successfully pursued forcible entry and detainer actions on behalf of the Alaska Housing Finance Corporation in several for-cause evictions in FY2021.

Child Support: In FY2021, the Child Support Unit opened or re-opened 419 child support matters. The Child Support Unit also assisted DOR's Child Support Services Division both in meeting its federal deadlines and remaining in compliance with its state plan. This is important because the Child Support Services Division is 66 percent federally funded.

Key Component Challenges

The diversity and volume of agency work presents a steady demand for legal services from the various divisions, boards, and commissions within the Department of Commerce, Community, and Economic Development, particularly with the implementation of the marijuana initiative and the larger role played by professional licensing boards. Section attorneys spend substantial time every year researching, analyzing, and advising the agencies on statutory licensing and enforcement requirements. Many are issues of first impression, that are not governed by legal precedent or binding authority, so extensive research of legislative history or authorities from other jurisdictions is necessary to provide agencies appropriate guidance and advice.

Significant Changes in Results to be Delivered in FY2023

The state and its citizens benefit significantly from the section's work to protect the public while encouraging economic growth.

The section anticipates an increase in services to be delivered to the Department of Commerce, Community, and Economic Development related to professional licensing regulation changes, as well as national trends in professional licensing. The section also expects a continued increase in the need for legal services related to the rapid growth of the marijuana industry and the evolution of the alcohol industry.

Statutory and Regulatory Authority

AS 25.27.050
AS 44.23.020

Contact Information
<p>Contact: Rebecca Cain, Chief Assistant Attorney General Phone: (907) 269-5100 E-mail: rebecca.cain@alaska.gov</p>

Commercial and Fair Business Personal Services Information				
Authorized Positions			Personal Services Costs	
	<u>FY2022</u> <u>Management</u> <u>Plan</u>	<u>FY2023</u> <u>Governor</u>		
Full-time	19	20	Annual Salaries	1,956,527
Part-time	0	0	COLA	858
Nonpermanent	0	0	Premium Pay	0
			Annual Benefits	1,124,148
			<i>Less 2.75% Vacancy Factor</i>	<i>(84,633)</i>
			Lump Sum Premium Pay	0
Totals	19	20	Total Personal Services	2,996,900

Position Classification Summary					
Job Class Title	Anchorage	Fairbanks	Juneau	Others	Total
Associate Attorney 1	2	0	0	0	2
Attorney 4	3	0	0	0	3
Attorney 5	5	0	2	0	7
Attorney 6	1	0	0	0	1
Investigator 3	1	0	0	0	1
Law Office Assistant 1	3	0	1	0	4
Law Office Assistant 2	1	0	0	0	1
Paralegal 2	1	0	0	0	1
Totals	17	0	3	0	20

Component Detail All Funds
Department of Law

Component: Commercial and Fair Business (2717)
RDU: Civil Division (Excludes Janus) (35)

Non-Formula Component

	FY2021 Actuals	FY2022 Conference Committee	FY2022 Authorized	FY2022 Management Plan	FY2023 Governor	FY2022 Management Plan vs FY2023 Governor	
71000 Personal Services	3,396.4	3,665.5	3,665.5	2,839.4	2,996.9	157.5	5.5%
72000 Travel	8.2	38.7	38.7	38.7	38.7	0.0	0.0%
73000 Services	1,249.8	1,751.0	1,751.0	1,751.0	1,751.0	0.0	0.0%
74000 Commodities	43.6	102.1	102.1	102.1	102.1	0.0	0.0%
75000 Capital Outlay	12.9	0.6	0.6	0.6	0.6	0.0	0.0%
77000 Grants, Benefits	0.0	0.0	0.0	0.0	0.0	0.0	0.0%
78000 Miscellaneous	0.0	0.0	0.0	0.0	0.0	0.0	0.0%
Totals	4,710.9	5,557.9	5,557.9	4,731.8	4,889.3	157.5	3.3%
Fund Sources:							
1004 Gen Fund (UGF)	466.5	705.0	705.0	705.0	613.8	-91.2	-12.9%
1005 GF/Prgm (DGF)	0.0	136.0	136.0	136.0	136.0	0.0	0.0%
1007 I/A Rcpts (Other)	3,223.1	3,674.7	3,674.7	2,848.6	3,093.4	244.8	8.6%
1108 Stat Desig (Other)	918.5	937.4	937.4	937.4	940.8	3.4	0.4%
1168 Tob Ed/Ces (DGF)	102.8	104.8	104.8	104.8	105.3	0.5	0.5%
Unrestricted General (UGF)	466.5	705.0	705.0	705.0	613.8	-91.2	-12.9%
Designated General (DGF)	102.8	240.8	240.8	240.8	241.3	0.5	0.2%
Other Funds	4,141.6	4,612.1	4,612.1	3,786.0	4,034.2	248.2	6.6%
Federal Funds	0.0	0.0	0.0	0.0	0.0	0.0	0.0%
Positions:							
Permanent Full Time	25	24	24	19	20	1	5.3%
Permanent Part Time	0	0	0	0	0	0	0.0%
Non Permanent	0	0	0	0	0	0	0.0%

Change Record Detail - Multiple Scenarios with Descriptions
Department of Law

Component: Commercial and Fair Business (2717)
RDU: Civil Division (Excludes Janus) (35)

Scenario/Change Record Title	Trans Type	Totals	Personal Services	Travel	Services	Commodities	Capital Outlay	Grants, Benefits	Miscellaneous	Positions		NP
										PFT	PPT	
***** Changes From FY2022 Conference Committee To FY2022 Authorized *****												
FY2022 Conference Committee												
	ConfCom	5,557.9	3,665.5	38.7	1,751.0	102.1	0.6	0.0	0.0	24	0	0
1004 Gen Fund		705.0										
1005 GF/Prgm		136.0										
1007 I/A Rcpts		3,674.7										
1108 Stat Desig		937.4										
1168 Tob Ed/Ces		104.8										
Subtotal		5,557.9	3,665.5	38.7	1,751.0	102.1	0.6	0.0	0.0	24	0	0
***** Changes From FY2022 Authorized To FY2022 Management Plan *****												
Transfer Two Attorney Positions to Transportation for Required Legal Expertise												
	Trout	-347.8	-347.8	0.0	0.0	0.0	0.0	0.0	0.0	-2	0	0
1007 I/A Rcpts		-347.8										
Transfer two full-time Attorney 4 positions (03-0044 and 03-0094), range 24, located in Juneau and Anchorage, to the Transportation component from the Commercial and Fair Business component to keep pace with the required level of legal expertise needed within the office. The remaining staff in Commercial and Fair Business are sufficient to accommodate anticipated workload.												
Transfer Two Attorney Positions to Special Litigation for Required Legal Expertise												
	Trout	-308.2	-308.2	0.0	0.0	0.0	0.0	0.0	0.0	-2	0	0
1007 I/A Rcpts		-308.2										
Transfer one full-time Attorney 3 position (03-0055), range 22 and one full-time Attorney 4 position (03-0428), range 24, both located in Anchorage, to the Special Litigation component from the Commercial and Fair Business component to keep pace with the required level of legal expertise needed within the office. The remaining staff in Commercial and Fair Business are sufficient to accommodate anticipated workload.												
Transfer Attorney 4 (03-0082) to Information and Project Support for Required Legal Expertise												
	Trout	-170.1	-170.1	0.0	0.0	0.0	0.0	0.0	0.0	-1	0	0
1007 I/A Rcpts		-170.1										
Transfer one full-time Attorney 4 position (03-0082), range 24, located in Anchorage, to the Information and Project Support component from the Commercial and Fair Business component to keep pace with the required level of legal expertise needed within the office. The remaining staff in Commercial and Fair Business are sufficient to accommodate anticipated workload.												
Subtotal		4,731.8	2,839.4	38.7	1,751.0	102.1	0.6	0.0	0.0	19	0	0
***** Changes From FY2022 Management Plan To FY2023 Governor *****												
FY2023 Salary and Benefit Adjustments												
	SalAdj	0.9	0.9	0.0	0.0	0.0	0.0	0.0	0.0	0	0	0

Change Record Detail - Multiple Scenarios with Descriptions
Department of Law

Component: Commercial and Fair Business (2717)
RDU: Civil Division (Excludes Janus) (35)

Scenario/Change Record Title	Trans Type	Totals	Personal Services	Travel	Services	Commodities	Capital Outlay	Grants, Benefits	Miscellaneous	Positions		NP
										PFT	PPT	
1007 I/A Rcpts		0.9										
FY2023 SU BU - Supervisory Employees (SS) 1% COLA: \$0.9												
FY2023 Executive Health Insurance, SBS, and Risk Management Rate Changes												
	SalAdj	23.1	23.1	0.0	0.0	0.0	0.0	0.0	0.0	0	0	0
1004 Gen Fund		3.9										
1007 I/A Rcpts		15.6										
1108 Stat Desig		3.1										
1168 Tob Ed/Ces		0.5										
FY2023 Change Partially Exempt & Exempt Executive (EE) - Health Insurance from \$1,555 to \$1,685; SBS and Risk Management Rates: \$23.1												
FY2023 Supervisory Employees Health Insurance, SBS, and Risk Management Rate Changes												
	SalAdj	1.7	1.7	0.0	0.0	0.0	0.0	0.0	0.0	0	0	0
1007 I/A Rcpts		1.7										
FY2023 Change Supervisory Employees (SS) - Health Insurance from \$1,555 to \$1,685; SBS and Risk Management Rates: \$1.7												
FY2023 General Government Unit SBS and Risk Management Rate Changes												
	SalAdj	0.9	0.9	0.0	0.0	0.0	0.0	0.0	0.0	0	0	0
1007 I/A Rcpts		0.6										
1108 Stat Desig		0.3										
FY2023 Change General Government Unit (GG, GP, GY, GZ) - SBS, and Risk Management Rates: \$0.9												
FY2023 PERS Actuarial Rate Adjustment to 24.79% Ch9 SLA2021 (SB55)												
	SalAdj	-95.1	-95.1	0.0	0.0	0.0	0.0	0.0	0.0	0	0	0
1004 Gen Fund		-11.4										
1007 I/A Rcpts		-68.6										
1108 Stat Desig		-13.5										
1168 Tob Ed/Ces		-1.6										
Includes: FY2023 Adjustment for PERS ARM Board Approved Rate of 24.79% (from 30.11%): \$-95.1												
Transfer Attorney 5 (03-0069) from Transportation for Required Legal Expertise												
	Trin	226.0	226.0	0.0	0.0	0.0	0.0	0.0	0.0	1	0	0
1007 I/A Rcpts		226.0										
Transfer one full-time Attorney 5 position (03-0069), range 25, located in Anchorage, from the Transportation component to the Commercial and Fair Business component to keep pace with the required level of legal expertise needed within the office. The remaining staff in Transportation are sufficient to accommodate anticipated workload.												

Change Record Detail - Multiple Scenarios with Descriptions
Department of Law

Component: Commercial and Fair Business (2717)
RDU: Civil Division (Excludes Janus) (35)

Scenario/Change Record Title	Trans Type	Totals	Personal Services	Travel	Services	Commodities	Capital Outlay	Grants, Benefits	Miscellaneous	Positions		NP
										PFT	PPT	
Transfer Attorney 5 (03-0315) from Torts and Workers' Compensation for Required Legal Expertise												
	Trin	0.0	0.0	0.0	0.0	0.0	0.0	0.0	0.0	1	0	0
Transfer one full-time Attorney 5 position (03-0315), range 25, located in Anchorage, from the Torts and Workers' Compensation component to the Commercial and Fair Business component to keep pace with the required level of legal expertise needed within the office. The remaining staff in Torts and Workers' Compensation are sufficient to accommodate anticipated workload.												
Transfer Attorney 4 (03-0142) to Torts and Workers' Compensation for Required Legal Expertise												
	Trout	0.0	0.0	0.0	0.0	0.0	0.0	0.0	0.0	-1	0	0
Transfer one full-time Attorney 4 position (03-0142), range 24, located in Anchorage, from the Commercial and Fair Business component to the Torts and Workers' Compensation component to keep pace with the required level of legal expertise needed within the office. The remaining staff in Commercial and Fair Business are sufficient to accommodate anticipated workload.												
Realign PERS Rate Adjustment by Fund Source Ch9 SLA2021 (SB55)												
	FndChg	0.0	0.0	0.0	0.0	0.0	0.0	0.0	0.0	0	0	0
1004 Gen Fund		-83.7										
1007 I/A Rcpts		68.6										
1108 Stat Desig		13.5										
1168 Tob Ed/Ces		1.6										
Remove one-time UGF subsidy for rate agency assigned in SB55 fiscal note (Ch 9 SLA 2021).												
Totals		4,889.3	2,996.9	38.7	1,751.0	102.1	0.6	0.0	0.0	20	0	0

Line Item Detail (1676)
Department of Law
Travel

Component: Commercial and Fair Business (2717)

Line Number	Line Name		FY2021 Actuals	FY2022 Management Plan	FY2023 Governor
2000	Travel		8.2	38.7	38.7
Object Class	Servicing Agency	Explanation	FY2021 Actuals	FY2022 Management Plan	FY2023 Governor
2000 Travel Detail Totals			8.2	38.7	38.7
2000	In-State Employee Travel	Travel for attorneys to interview witnesses and attend court proceedings, as well as for necessary training for both attorneys and paraprofessionals. Includes travel for management purposes.	0.5	21.0	21.0
2001	In-State Non-Employee Travel	Travel costs for witnesses to testify in court.	0.0	5.0	5.0
2002	Out of State Employee Travel	Travel costs and expenses for out-of-state travel for conferences, training, etc.	0.4	5.2	5.2
2006	Other Travel Costs	Travel cost transfers.	7.3	7.5	7.5

Line Item Detail (1676)
Department of Law
Services

Component: Commercial and Fair Business (2717)

Line Number	Line Name		FY2021 Actuals	FY2022 Management Plan	FY2023 Governor
3000	Services		1,249.8	1,751.0	1,751.0
Object Class	Servicing Agency	Explanation	FY2021 Actuals	FY2022 Management Plan	FY2023 Governor
3000 Services Detail Totals			1,249.8	1,751.0	1,751.0
3000	Education Services	Conferences, training and memberships.	8.6	10.0	10.0
3001	Financial Services	Bankcard service fees.	0.4	1.0	1.0
3002	Legal and Judicial Services	Depositions, research costs, expert witness and consultant fees.	462.7	627.0	627.0
3003	Information Technology	Training, consulting and software licensing and maintenance. Annual maintenance fee for mission-critical information management systems.	1.9	2.0	2.0
3004	Telecommunications	Local telephone service, long distance charges and cellular phone services paid to third-party telephone utilities.	0.5	1.0	1.0
3006	Delivery Services	Freight, courier, postage, and transportation of trial exhibit materials.	15.7	20.0	20.0
3011	Other Services	Cost transfers and miscellaneous items within the services line (commissions, etc.).	531.2	775.6	775.6
3013	Inter-Agency Data Processing Operations Allocation	Law - Administrative Services (2164) RSA Law, Information services, data processing investments and support.	14.3	15.0	15.0
3017	Inter-Agency Information Technology Non-Telecommunications	Admin - Department-wide RSA Administration, Office of Information Technology computer services.	4.0	12.2	12.2
3018	Inter-Agency Information Technology Telecommunications	Admin - Department-wide RSA Administration, Office of Information Technology telecommunications services.	0.5	1.0	1.0

Line Item Detail (1676)
Department of Law
Services

Component: Commercial and Fair Business (2717)

Object Class		Servicing Agency	Explanation	FY2021 Actuals	FY2022 Management Plan	FY2023 Governor
3000 Services Detail Totals				1,249.8	1,751.0	1,751.0
3022	Inter-Agency Human Resources	Law - Administrative Services (2164)	RSA Law, Human Resources position.	0.9	1.0	1.0
3023	Inter-Agency Building Leases		Leased office space managed by General Services.	9.5	10.0	10.0
3024	Inter-Agency Legal	Law - Criminal Appeals/Special Lit (2203)	RSA Law, Criminal Appeals/Special Litigation - child support enforcement matters.	199.4	275.0	275.0
3026	Inter-Agency Insurance		RSA Administration, Risk Management.	0.1	0.1	0.1
3027	Inter-Agency Financial	Admin - Department-wide	RSA Administration, Finance Chargeback (IRIS).	0.1	0.1	0.1

Line Item Detail (1676)
Department of Law
Commodities

Component: Commercial and Fair Business (2717)

Line Number	Line Name		FY2021 Actuals	FY2022 Management Plan	FY2023 Governor
4000	Commodities		43.6	102.1	102.1
Object Class	Servicing Agency	Explanation	FY2021 Actuals	FY2022 Management Plan	FY2023 Governor
4000 Commodities Detail Totals			43.6	102.1	102.1
4000	Business	Reference materials and subscriptions, including statutes, software applications, non-capital desktop refresh, and miscellaneous office supplies.	6.4	6.5	6.5
4022	Commodity Transfer	Commodity cost transfers.	37.2	95.6	95.6

Line Item Detail (1676)
Department of Law
Capital Outlay

Component: Commercial and Fair Business (2717)

Line Number	Line Name		FY2021 Actuals	FY2022 Management Plan	FY2023 Governor
5000	Capital Outlay		12.9	0.6	0.6
Object Class	Servicing Agency	Explanation	FY2021 Actuals	FY2022 Management Plan	FY2023 Governor
5000 Capital Outlay Detail Totals			12.9	0.6	0.6
5009	Capital Outlay Transfer	Capital cost transfers.	12.9	0.6	0.6

Revenue Detail (1681)
Department of Law

Component: Commercial and Fair Business (2717)

Revenue Type (OMB Fund Code) Revenue Source	Component	Comment	FY2021 Actuals	FY2022 Management Plan	FY2023 Governor
5005 GF/Prgm (1005 GF/Prgm)			0.0	136.0	136.0
5101 Program Receipts Public Protection - Licenses and Permits		Receipts from licenses and permits	0.0	136.0	136.0
5007 I/A Rcpts (1007 I/A Rcpts)			3,223.1	2,848.6	3,093.4
5301 Inter-Agency Receipts	Admin - Department-wide	RSA Administration, Shared Services of Alaska - legal services to support the Collections Unit. Program code: CV03203545.	0.6	5.0	5.0
5301 Inter-Agency Receipts	Commerce - Department-wide	RSA Commerce, Alcohol Control Board and Marijuana Control Board - legal services. Program code: CV03203560.	170.8	170.0	170.0
5301 Inter-Agency Receipts	E&ED - Department-wide	RSA Education, Alaska Commission on Post-secondary Education - legal services. Program code: CV03203519.	79.8	80.0	80.0
5301 Inter-Agency Receipts	NatRes - Department-wide	RSA Natural Resources, Agriculture - legal services for the Agricultural Revolving Loan Fund. Program code: CV03203551.	20.0	15.0	15.0
5301 Inter-Agency Receipts	Rev - Department-wide	RSA Revenue, Alaska Housing Finance Corporation - legal support services. Program code: CV03203527.	285.4	275.0	275.0
5301 Inter-Agency Receipts	Commerce - Department-wide	RSA Commerce, Banking and Securities - legal services. Program code: CV03203552.	91.6	90.0	90.0
5301 Inter-Agency Receipts	E&ED - Department-wide	RSA Education, Alaska Student Loan Corporation - legal services. Program code: CV03203659.	42.0	42.0	42.0
5301 Inter-Agency Receipts	Rev - Department-wide	RSA Revenue, Alaska Housing Finance Corporation - outside counsel legal support services (Wohlforth). Program code: CV03203531.	389.6	300.0	300.0

Revenue Detail (1681)
Department of Law

Component: Commercial and Fair Business (2717)

Revenue Type (OMB Fund Code) Revenue Source	Component	Comment	FY2021 Actuals	FY2022 Management Plan	FY2023 Governor
5301 Inter-Agency Receipts	Commerce - Department-wide	RSA Commerce, Division of Corporations, Business and Professional Licensing - legal services. Program code: CV03203530.	603.3	550.0	550.0
5301 Inter-Agency Receipts	E&ED - Department-wide	RSA Education, Professional Teaching Practices Commission - legal services. Program code: CV03203558.	19.1	20.0	20.0
5301 Inter-Agency Receipts	Rev - Department-wide	RSA Revenue, Child Support Services - legal services to enforce child support orders. Program code: CV03202534.	802.4	600.0	800.0
5301 Inter-Agency Receipts	Commerce - Department-wide	RSA Commerce, Division of Economic Development - legal services for the Investments section. Program code: CV03203543.	3.2	5.0	5.0
5301 Inter-Agency Receipts	Rev - Department-wide	RSA Revenue, Permanent Fund Dividend - legal services related to permanent fund dividend matters. Program code: CV03203529.	65.8	65.0	65.0
5301 Inter-Agency Receipts	Commerce - Department-wide	RSA Commerce, Division of Insurance - legal services. Program code: CV03203542.	474.9	450.0	460.0
5301 Inter-Agency Receipts	Rev - Department-wide	RSA Revenue, Tax - legal services for the Tobacco and Charitable Gaming sections. Program code: CV03203517.	12.6	13.0	12.6
5301 Inter-Agency Receipts	Commerce - Department-wide	RSA Commerce, Regulatory Commission of Alaska - legal services. Program code: CV03203537.	126.5	130.0	130.0
5301 Inter-Agency Receipts	Rev - Department-wide	RSA Revenue, Alaska Permanent Fund Corporation - legal services. Program code: CV0320APFC.	26.5	25.0	50.0
5301 Inter-Agency Receipts	Rev - Department-wide	RSA Revenue, Alaska Retirement	9.0	13.6	23.8

Revenue Detail (1681)
Department of Law

Component: Commercial and Fair Business (2717)

Revenue Type (OMB Fund Code) Revenue Source	Component	Comment	FY2021 Actuals	FY2022 Management Plan	FY2023 Governor
		Management Board - taxation and treasury legal services. Program code: CV0320ARMB.			
5108 Stat Desig (1108 Stat Desig)			918.5	937.4	940.8
5201 Statutory Dsgntd Prgrm Rcpts Pblc Prtctn - Permits and Fees		Receipts from permits and fees	918.5	937.4	940.8
6004 Gen Fund (1004 Gen Fund)			5,271.0	0.0	0.0
6004 General Fund Public Protection - Judgement Settlemnt		Judgments and settlements	5,045.6	0.0	0.0
6011 General Fund Gnrl Gov - Chrsg for Svcs Misc Receipts		Miscellaneous receipts	0.9	0.0	0.0
6012 General Fund Gnrl Gov - Charges for Services Filing Fees		Receipts for filing fees	224.5	0.0	0.0
6168 Tob Ed/Ces (1168 Tob Ed/Ces)			102.8	104.8	105.3
6811 Tobacco Use Education and Cessation Fund - Tobacco Settlemnt		Tobacco settlement funds	102.8	104.8	105.3

Inter-Agency Services (1682)
Department of Law

Component: Commercial and Fair Business (2717)

				FY2021 Actuals	FY2022 Management Plan	FY2023 Governor
Component Totals				219.2	304.3	304.3
With Department of Law				214.6	291.0	291.0
With Department of Administration				4.6	13.3	13.3
Object Class	Servicing Agency	Explanation		FY2021 Actuals	FY2022 Management Plan	FY2023 Governor
3013	Inter-Agency Data Processing Operations Allocation	Law - Administrative Services (2164)	RSA Law, Information services, data processing investments and support.	14.3	15.0	15.0
3017	Inter-Agency Information Technology Non-Telecommunications	Admin - Department-wide	RSA Administration, Office of Information Technology computer services.	4.0	12.2	12.2
3018	Inter-Agency Information Technology Telecommunications	Admin - Department-wide	RSA Administration, Office of Information Technology telecommunications services.	0.5	1.0	1.0
3022	Inter-Agency Human Resources	Law - Administrative Services (2164)	RSA Law, Human Resources position.	0.9	1.0	1.0
3024	Inter-Agency Legal	Law - Criminal Appeals/Special Lit (2203)	RSA Law, Criminal Appeals/Special Litigation - child support enforcement matters.	199.4	275.0	275.0
3027	Inter-Agency Financial	Admin - Department-wide	RSA Administration, Finance Chargeback (IRIS).	0.1	0.1	0.1

Personal Services Expenditure Detail
Department of Law

Scenario: FY2023 Governor (18673)
Component: Commercial and Fair Business (2717)
RDU: Civil Division (Excludes Janus) (35)

PCN	Job Class Title	Time Status	Retire Code	Barg Unit	Location	Salary Sched	Range / Step	Comp Months	Split / Count	Annual Salaries	COLA	Premium Pay	Annual Benefits	Total Costs	UGF Amount
03-0004	Attorney 6	FT	A	XE	Anchorage	N00	26P / Q	12.0		152,473	0	0	76,649	229,122	45,824
03-0033	Attorney 5	FT	A	XE	Anchorage	N00	25Q	12.0		147,771	0	0	75,187	222,958	44,592
03-0051	Law Office Assistant 1	FT	A	GP	Juneau	205	11D / E	12.0		43,878	0	0	35,117	78,995	0
03-0069	Attorney 5	FT	A	XE	Anchorage	N00	25K / L	12.0		125,931	0	0	67,121	193,052	0
03-0079	Law Office Assistant 1	FT	A	GP	Anchorage	200	11D / E	12.0		41,858	0	0	34,365	76,223	11,434
03-0140	Attorney 5	FT	A	XE	Anchorage	99	25O / P	12.0		144,204	0	0	73,924	218,128	43,626
03-0157	Associate Attorney 1	FT	A	XE	Anchorage	N00	17B / C	12.0		58,225	0	0	41,914	100,139	100,139
03-0209	Attorney 4	FT	A	XE	Anchorage	N00	24F	12.0		106,451	0	0	59,869	166,320	0
03-0229	Attorney 5	FT	A	XE	Juneau	N05	25N / O	12.0		145,184	0	0	74,289	219,473	0
03-0233	Attorney 4	FT	A	XE	Anchorage	N00	24M	12.0		120,978	0	0	65,277	186,255	0
03-0234	Law Office Assistant 1	FT	A	GP	Anchorage	200	11D / E	12.0		41,455	0	0	34,215	75,670	0
03-0269	Law Office Assistant 1	FT	A	GP	Anchorage	200	11C	12.0		40,053	0	0	33,693	73,746	0
03-0303	Attorney 4	FT	A	XE	Anchorage	N00	24L / M	12.0		120,978	0	0	65,277	186,255	37,251
03-0315	Attorney 5	FT	A	XE	Anchorage	N00	25P / Q	12.0		143,904	0	0	73,813	217,717	0
03-0329	Law Office Assistant 2	FT	A	SS	Anchorage	99	13M / N	12.0		62,489	858	0	43,646	106,993	0
03-0335	Paralegal 2	FT	A	GP	Anchorage	99	16N / O	12.0		78,158	0	0	47,880	126,038	0
03-0343	Investigator 3	FT	A	GP	Anchorage	200	18D / E	12.0		68,126	0	0	44,145	112,271	0
03-0365	Associate Attorney 1	FT	A	XE	Anchorage	N00	17C / D	12.0		60,404	0	0	42,726	103,130	0
03-0420	Attorney 5	FT	A	XE	Anchorage	N00	25L	12.0		125,931	0	0	67,121	193,052	61,777
03-1339	Attorney 5	FT	A	XE	Juneau	N05	25K	12.0		128,076	0	0	67,920	195,996	0
													Total Salary Costs:	1,956,527	
													Total COLA:	858	
													Total Premium Pay:	0	
													Total Benefits:	1,124,148	
													Total Pre-Vacancy:	3,081,533	
													Minus Vacancy Adjustment of 2.75%:	(84,633)	
													Total Post-Vacancy:	2,996,900	
													Plus Lump Sum Premium Pay:	0	
													Personal Services Line 100:	2,996,900	
		Total Positions	New	Deleted											
Full Time Positions:		20	0	0											
Part Time Positions:		0	0	0											
Non Permanent Positions:		0	0	0											
Positions in Component:		20	0	0											
Total Component Months:		240.0													

Note: If a position is split, an asterisk (*) will appear in the Split/Count column. If the split position is also counted in the component, two asterisks (**) will appear in this column. [No valid job title] appearing in the Job Class Title indicates that the PCN has an invalid class code or invalid range for the class code effective date of this scenario.

Personal Services Expenditure Detail
Department of Law

Scenario: FY2023 Governor (18673)
Component: Commercial and Fair Business (2717)
RDU: Civil Division (Excludes Janus) (35)

PCN Funding Sources:	Pre-Vacancy	Post-Vacancy	Percent
1004 General Fund Receipts	344,642	335,176	11.18%
1007 Interagency Receipts	2,261,489	2,199,378	73.39%
1108 Statutory Designated Program Receipts	428,838	417,060	13.92%
1168 Tobacco Use Education and Cessation Fund	46,564	45,285	1.51%
Total PCN Funding:	3,081,533	2,996,900	100.00%

Note: If a position is split, an asterisk (*) will appear in the Split/Count column. If the split position is also counted in the component, two asterisks (**) will appear in this column.
 [No valid job title] appearing in the Job Class Title indicates that the PCN has an invalid class code or invalid range for the class code effective date of this scenario.

CIVIL DIVISION

Commercial and Fair Business

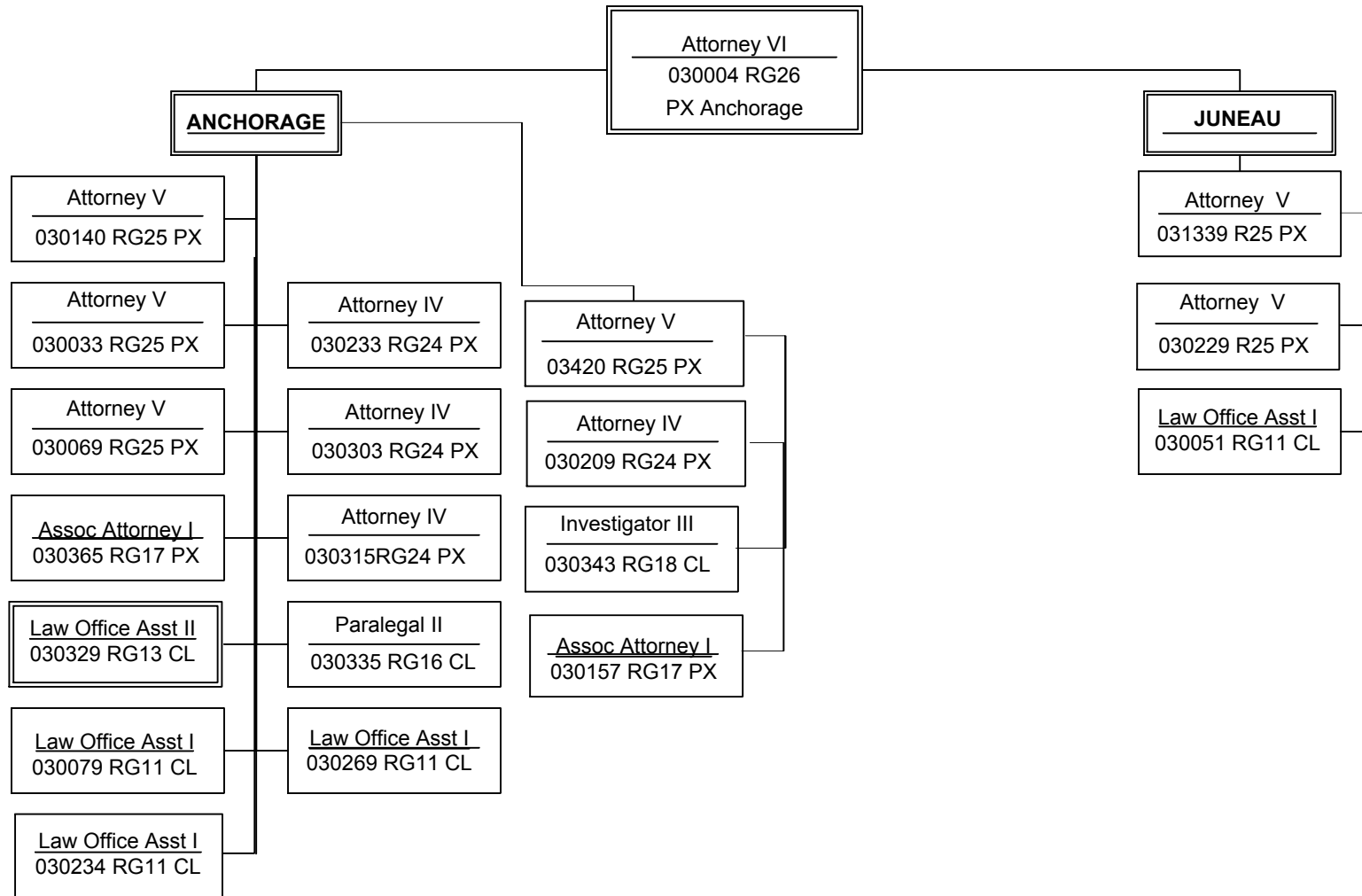

State of Alaska FY2023 Governor's Operating Budget

Department of Law Environmental Law Component Budget Summary

Component: Environmental Law

Contribution to Department's Mission

The Environmental Law section provides advice and legal representation to state agencies, primarily the Department of Environmental Conservation (DEC), on state and federal environmental laws and programs.

Core Services

- Section attorneys assist DEC with implementation and enforcement of state environmental laws and regulations.
- The section advises and defends DEC in administrative appeals of DEC decisions and certifications.
- When spills occur, section attorneys provide investigative, enforcement, and litigation services to ensure prompt and complete response, and reimbursement of state costs and damages.
- The section advises DEC on air and water discharge permitting and enforcement.
- The section provides legal advice and representation to DEC on public health issues such as food safety, animal health, pesticides, solid waste, and drinking water.

Major Component Accomplishments in 2021

In FY2021, the section assisted DEC in recovering \$1,740,556 for civil assessments, state costs recovery and penalties related to violations of state environmental laws and spills. Costs associated with operating the section totaled \$1,161,300 for all fund sources.

Key Component Challenges

- Recovering costs of DEC oversight and cleanup costs of spill response and contaminated sites, and diminished ability to pursue cleanup of "lingering contaminated sites" where no responsible party is undertaking a cleanup.
- Defending challenges to DEC decisions before the Office of Administrative Hearings.
- Engaging federal agencies on matters and decisions that affect the state's interests. The section provides legal advice and representation on federal regulatory or administrative actions and rulemakings and to represent state agency interests, either to support or to challenge federal rules.

Significant Changes in Results to be Delivered in FY2023

No significant changes are anticipated in the next fiscal year.

Statutory and Regulatory Authority

AS 44.23.020

AS 46.08.070

Contact Information

Contact: Jennifer Currie, Chief Assistant Attorney General

Phone: (907) 269-5100

E-mail: jennifer.currie@alaska.gov

Environmental Law Personal Services Information				
Authorized Positions			Personal Services Costs	
	<u>FY2022</u> <u>Management</u> <u>Plan</u>	<u>FY2023</u> <u>Governor</u>		
Full-time	11	11	Annual Salaries	1,010,064
Part-time	0	0	Premium Pay	0
Nonpermanent	0	0	Annual Benefits	592,664
			<i>Less 3.88% Vacancy Factor</i>	(62,128)
			Lump Sum Premium Pay	0
Totals	11	11	Total Personal Services	1,540,600

Position Classification Summary					
Job Class Title	Anchorage	Fairbanks	Juneau	Others	Total
Associate Attorney 2	1	0	0	0	1
Attorney 2	1	0	0	0	1
Attorney 3	2	0	0	0	2
Attorney 4	2	0	0	0	2
Attorney 5	1	0	0	0	1
Attorney 6	1	0	0	0	1
Law Office Assistant 1	2	0	0	0	2
Paralegal 2	1	0	0	0	1
Totals	11	0	0	0	11

Component Detail All Funds
Department of Law

Component: Environmental Law (2092)
RDU: Civil Division (Excludes Janus) (35)

Non-Formula Component

	FY2021 Actuals	FY2022 Conference Committee	FY2022 Authorized	FY2022 Management Plan	FY2023 Governor	FY2022 Management Plan vs FY2023 Governor	
71000 Personal Services	901.5	1,577.2	1,577.2	1,577.2	1,540.6	-36.6	-2.3%
72000 Travel	3.0	20.0	20.0	20.0	20.0	0.0	0.0%
73000 Services	243.3	400.5	400.5	400.5	400.5	0.0	0.0%
74000 Commodities	10.0	9.0	9.0	9.0	9.0	0.0	0.0%
75000 Capital Outlay	3.5	0.0	0.0	0.0	0.0	0.0	0.0%
77000 Grants, Benefits	0.0	0.0	0.0	0.0	0.0	0.0	0.0%
78000 Miscellaneous	0.0	0.0	0.0	0.0	0.0	0.0	0.0%
Totals	1,161.3	2,006.7	2,006.7	2,006.7	1,970.1	-36.6	-1.8%
Fund Sources:							
1004 Gen Fund (UGF)	161.8	764.9	764.9	764.9	717.2	-47.7	-6.2%
1007 I/A Rcpts (Other)	604.6	769.8	769.8	769.8	777.4	7.6	1.0%
1055 IA/OIL HAZ (Other)	259.7	472.0	472.0	472.0	475.5	3.5	0.7%
1061 CIP Rcpts (Other)	135.2	0.0	0.0	0.0	0.0	0.0	0.0%
Unrestricted General (UGF)	161.8	764.9	764.9	764.9	717.2	-47.7	-6.2%
Designated General (DGF)	0.0	0.0	0.0	0.0	0.0	0.0	0.0%
Other Funds	999.5	1,241.8	1,241.8	1,241.8	1,252.9	11.1	0.9%
Federal Funds	0.0	0.0	0.0	0.0	0.0	0.0	0.0%
Positions:							
Permanent Full Time	11	11	11	11	11	0	0.0%
Permanent Part Time	0	0	0	0	0	0	0.0%
Non Permanent	0	0	0	0	0	0	0.0%

Change Record Detail - Multiple Scenarios with Descriptions
Department of Law

Component: Environmental Law (2092)
RDU: Civil Division (Excludes Janus) (35)

Scenario/Change Record Title	Trans Type	Totals	Personal Services	Travel	Services	Commodities	Capital Outlay	Grants, Benefits	Miscellaneous	Positions		NP
										PFT	PPT	
***** Changes From FY2022 Conference Committee To FY2022 Authorized *****												
FY2022 Conference Committee												
	ConfCom	2,006.7	1,577.2	20.0	400.5	9.0	0.0	0.0	0.0	11	0	0
1004 Gen Fund		764.9										
1007 I/A Rcpts		769.8										
1055 IA/OIL HAZ		472.0										
Subtotal		2,006.7	1,577.2	20.0	400.5	9.0	0.0	0.0	0.0	11	0	0
***** Changes From FY2022 Authorized To FY2022 Management Plan *****												
Transfer Attorney 4 (03-0195) to Child Protection for Required Legal Expertise												
	Trout	0.0	0.0	0.0	0.0	0.0	0.0	0.0	0.0	-1	0	0
Transfer one full-time Attorney 4 position (03-0195), range 24, located in Anchorage, to the Child Protection component from the Environmental Law component to keep pace with the required level of legal expertise needed within the office. The remaining staff in Environmental Law are sufficient to accommodate anticipated workload.												
Transfer Attorney 2 (03-0379) from Opinions, Appeals and Ethics for Required Legal Expertise												
	Trin	0.0	0.0	0.0	0.0	0.0	0.0	0.0	0.0	1	0	0
Transfer one full-time Attorney 2 position (03-0379), range 20, located in Anchorage, from the Opinions, Appeals and Ethics component to the Environmental Law component to keep pace with the required level of legal expertise needed within the office. The remaining staff in Opinions, Appeals and Ethics are sufficient to accommodate anticipated workload. This position is recruited as an Attorney 4.												
Subtotal		2,006.7	1,577.2	20.0	400.5	9.0	0.0	0.0	0.0	11	0	0
***** Changes From FY2022 Management Plan To FY2023 Governor *****												
FY2023 Executive Health Insurance, SBS, and Risk Management Rate Changes												
	SalAdj	15.3	15.3	0.0	0.0	0.0	0.0	0.0	0.0	0	0	0
1004 Gen Fund		4.3										
1007 I/A Rcpts		7.5										
1055 IA/OIL HAZ		3.5										
FY2023 Change Partially Exempt & Exempt Executive (EE) - Health Insurance from \$1,555 to \$1,685; SBS and Risk Management Rates: \$15.3												
FY2023 General Government Unit SBS and Risk Management Rate Changes												
	SalAdj	0.4	0.4	0.0	0.0	0.0	0.0	0.0	0.0	0	0	0
1004 Gen Fund		0.3										
1007 I/A Rcpts		0.1										
FY2023 Change General Government Unit (GG, GP, GY, GZ) - SBS, and Risk Management Rates: \$0.4												

Change Record Detail - Multiple Scenarios with Descriptions
Department of Law

Component: Environmental Law (2092)
RDU: Civil Division (Excludes Janus) (35)

Scenario/Change Record Title	Trans Type	Totals	Personal Services	Travel	Services	Commodities	Capital Outlay	Grants, Benefits	Miscellaneous	Positions		NP
										PFT	PPT	
FY2023 PERS Actuarial Rate Adjustment to 24.79% Ch9 SLA2021 (SB55)												
	SalAdj	-52.3	-52.3	0.0	0.0	0.0	0.0	0.0	0.0	0	0	0
1004 Gen Fund		-17.6										
1007 I/A Rcpts		-24.1										
1055 IA/OIL HAZ		-10.6										
Includes: FY2023 Adjustment for PERS ARM Board Approved Rate of 24.79% (from 30.11%): \$-52.3												
Realign PERS Rate Adjustment by Fund Source Ch9 SLA2021 (SB55)												
	FndChg	0.0	0.0	0.0	0.0	0.0	0.0	0.0	0.0	0	0	0
1004 Gen Fund		-34.7										
1007 I/A Rcpts		24.1										
1055 IA/OIL HAZ		10.6										
Remove one-time UGF subsidy for rate agency assigned in SB55 fiscal note (Ch 9 SLA 2021).												
Totals		1,970.1	1,540.6	20.0	400.5	9.0	0.0	0.0	0.0	11	0	0

Line Item Detail (1676)
Department of Law
Travel

Component: Environmental Law (2092)

Line Number	Line Name		FY2021 Actuals	FY2022 Management Plan	FY2023 Governor
2000	Travel		3.0	20.0	20.0
Object Class	Servicing Agency	Explanation	FY2021 Actuals	FY2022 Management Plan	FY2023 Governor
2000 Travel Detail Totals			3.0	20.0	20.0
2000	In-State Employee Travel	Travel for attorneys to interview witnesses and attend court proceedings, as well as for necessary training for both attorneys and paraprofessionals. Includes travel for management purposes.	1.1	10.2	10.2
2002	Out of State Employee Travel	Travel costs and expenses for out-of-state travel for conferences, training, etc.	0.0	4.8	4.8
2006	Other Travel Costs	Travel cost transfers.	1.9	5.0	5.0

Line Item Detail (1676)
Department of Law
Services

Component: Environmental Law (2092)

Line Number	Line Name		FY2021 Actuals	FY2022 Management Plan	FY2023 Governor
3000	Services		243.3	400.5	400.5
Object Class	Servicing Agency	Explanation	FY2021 Actuals	FY2022 Management Plan	FY2023 Governor
3000 Services Detail Totals			243.3	400.5	400.5
3000	Education Services	Conferences, training and memberships.	6.1	10.0	10.0
3002	Legal and Judicial Services	Depositions, research costs, expert witness and consultant fees.	0.1	10.0	10.0
3006	Delivery Services	Freight, courier, postage, and transportation of trial exhibit materials.	0.1	3.0	3.0
3009	Structure/Infrastructure/Land	Rentals/leases - records and evidence storage.	0.0	15.0	15.0
3011	Other Services	Cost transfers and miscellaneous items within the services line (commissions, etc.).	237.0	362.5	362.5

Line Item Detail (1676)
Department of Law
Commodities

Component: Environmental Law (2092)

Line Number	Line Name		FY2021 Actuals	FY2022 Management Plan	FY2023 Governor
4000	Commodities		10.0	9.0	9.0
Object Class	Servicing Agency	Explanation	FY2021 Actuals	FY2022 Management Plan	FY2023 Governor
4000 Commodities Detail Totals			10.0	9.0	9.0
4022	Commodity Transfer	Commodity cost transfers.	10.0	9.0	9.0

Line Item Detail (1676)
Department of Law
Capital Outlay

Component: Environmental Law (2092)

Line Number	Line Name		FY2021 Actuals	FY2022 Management Plan	FY2023 Governor
5000	Capital Outlay		3.5	0.0	0.0
Object Class	Servicing Agency	Explanation	FY2021 Actuals	FY2022 Management Plan	FY2023 Governor
5000 Capital Outlay Detail Totals			3.5	0.0	0.0
5009	Capital Outlay Transfer	Capital cost transfers.	3.5	0.0	0.0

Revenue Detail (1681)
Department of Law

Component: Environmental Law (2092)

Revenue Type (OMB Fund Code) Revenue Source	Component	Comment	FY2021 Actuals	FY2022 Management Plan	FY2023 Governor
5007 I/A Rcpts (1007 I/A Rcpts)			604.6	769.8	777.4
5301 Inter-Agency Receipts	EnvCon - Department-wide	RSA Environmental Conservation, Water Quality - legal services. Program code: CV03204502.	217.0	250.0	250.0
5301 Inter-Agency Receipts	EnvCon - Department-wide	RSA Environmental Conservation, Water Quality - legal services provided for implementation of Commercial Passenger Vessel Environmental Compliance (CVPEC) law, air opacity and wastewater enforcement actions, and on-going services of a consultant expert to advise the state in pursuit of commercial passenger vessel air opacity violations. Program code: CV03204504.	21.7	50.0	50.0
5301 Inter-Agency Receipts	EnvCon - Department-wide	RSA Environmental Conservation, Air Quality - legal services. Program code: CV03204505.	52.5	75.0	75.0
5301 Inter-Agency Receipts	EnvCon - Department-wide	RSA Environmental Conservation, Environmental Health - legal services provided to the Food Safety & Sanitation section. Program code: CV03204506.	286.3	329.8	337.4
5301 Inter-Agency Receipts	EnvCon - Department-wide	RSA Environmental Conservation, Spill Prevention and Response - legal services supporting Department of Defense cleanup work. Program code: CV03204507.	26.3	50.0	50.0
5301 Inter-Agency Receipts	EnvCon - Department-wide	RSA Environmental Conservation, Commissioner's Office - legal services. Program code: CVEN18001.	0.8	15.0	15.0
5055 IA/OIL HAZ (1055 IA/OIL HAZ)			259.7	472.0	475.5
5391 Oil and Hazardous Waste Inter-Agency	EnvCon - Department-wide	RSA Environmental Conservation,	259.7	472.0	475.5

Revenue Detail (1681)
Department of Law

Component: Environmental Law (2092)

Revenue Type (OMB Fund Code) Revenue Source	Component	Comment	FY2021 Actuals	FY2022 Management Plan	FY2023 Governor
		Spill Prevention and Response - legal services. Program code: CV03204501.			
5061 CIP Rcpts (1061 CIP Rcpts)			135.2	0.0	0.0
5351 Capital Improvement Project Inter-Agency	Law - Environmental Law (2092)	Operating expenditures associated with capital project for Exxon Valdez Oil Spill record disposition and legal review. APTYP W06B.	135.2	0.0	0.0

Personal Services Expenditure Detail
Department of Law

Scenario: FY2023 Governor (18673)
Component: Environmental Law (2092)
RDU: Civil Division (Excludes Janus) (35)

PCN	Job Class Title	Time Status	Retire Code	Barg Unit	Location	Salary Sched	Range / Step	Comp Months	Split / Count	Annual Salaries	COLA	Premium Pay	Annual Benefits	Total Costs	UGF Amount
03-0045	Attorney 4	FT	A	XE	Anchorage	N00	24D / E	12.0		102,151	0	0	58,268	160,419	32,084
03-0059	Attorney 5	FT	A	XE	Anchorage	99	25Q	12.0		151,395	0	0	76,314	227,709	45,542
03-0113	Attorney 2	FT	A	XE	Anchorage	N00	20E / F	12.0		81,393	0	0	50,540	131,933	59,370
03-0235	Associate Attorney 2	FT	A	XE	Anchorage	99	19M	12.0		87,848	0	0	52,943	140,791	28,158
03-0242	Attorney 6	FT	A	XE	Anchorage	N00	26T	12.0		168,500	0	0	81,633	250,133	62,533
03-0246	Paralegal 2	FT	A	GP	Anchorage	200	16A / B	12.0		53,355	0	0	38,645	92,000	92,000
03-0301	Law Office Assistant 1	FT	A	GP	Anchorage	200	11D / E	12.0		41,858	0	0	34,365	76,223	76,223
03-0317	Attorney 3	FT	A	XE	Anchorage	N00	22C / D	12.0		85,917	0	0	52,224	138,141	69,071
03-0330	Law Office Assistant 1	FT	A	GP	Anchorage	200	11B / C	12.0		39,205	0	0	33,377	72,582	0
03-0379	Attorney 4	FT	A	XE	Anchorage	N00	24F	12.0		106,451	0	0	59,869	166,320	83,160
03-0386	Attorney 3	FT	A	XE	Anchorage	N00	22E / F	12.0		91,991	0	0	54,486	146,477	0

	Total Positions	New	Deleted	Total Salary Costs:	Total COLA:	Total Premium Pay:	Total Benefits:
				1,010,064	0	0	592,664
Full Time Positions:	11	0	0				
Part Time Positions:	0	0	0				
Non Permanent Positions:	0	0	0				
Positions in Component:	11	0	0				
				Total Pre-Vacancy:	1,602,728		
				Minus Vacancy Adjustment of 3.88%:	(62,128)		
				Total Post-Vacancy:	1,540,600		
				Plus Lump Sum Premium Pay:	0		
				Personal Services Line 100:	1,540,600		

PCN Funding Sources:	Pre-Vacancy	Post-Vacancy	Percent
1004 General Fund Receipts	548,140	526,892	34.20%
1007 Interagency Receipts	737,549	708,959	46.02%
1055 Interagency/Oil & Hazardous Waste	317,038	304,749	19.78%
Total PCN Funding:	1,602,728	1,540,600	100.00%

Note: If a position is split, an asterisk (*) will appear in the Split/Count column. If the split position is also counted in the component, two asterisks (**) will appear in this column. [No valid job title] appearing in the Job Class Title indicates that the PCN has an invalid class code or invalid range for the class code effective date of this scenario.

CIVIL DIVISION

Environmental Law

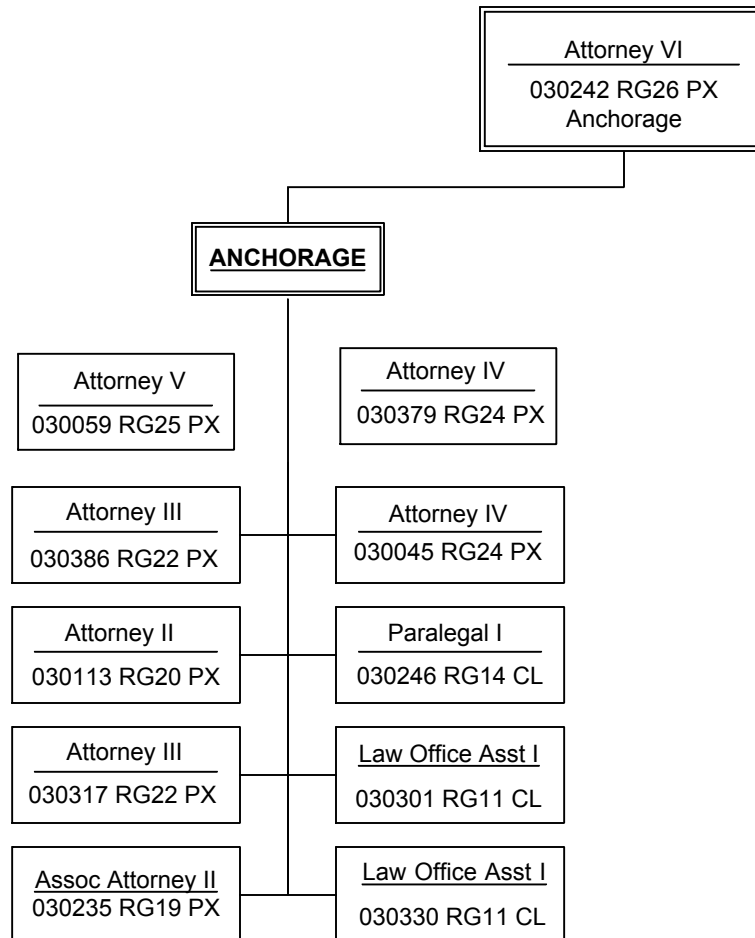

State of Alaska FY2023 Governor's Operating Budget

Department of Law Human Services Component Budget Summary

Component: Human Services

Contribution to Department's Mission

The Human Services Section provides advice and representation to the Department of Health and Social Services (DHSS) to assist it in the administration of its programs.

Core Services

- Assist DHSS to remain compliant with changes in state and federal laws.
- Assist DHSS with advice and representation in its public assistance programs (Medicaid, food stamps, public assistance, and heating assistance).
- Assist DHSS with advice and representation in its Senior and Disabilities Services programs (Medicaid waivers, personal care service programs, grants, general relief).
- Assist DHSS with advice and representation in its Behavioral Health programs [implementation of the 1135 Waiver, in-state and out-of-state residential treatment programs, Alaska Psychiatric Institute (API)].
- Assist DHSS with advice and representation in its mission to protect the health, safety and welfare of vulnerable children and adults through licensing and regulatory compliance of 693 assisted living homes, 44 residential child care facilities and residential psychiatric centers, 1235 active foster homes, and 480 licensed child day care facilities.
- Assist DHSS with advice and representation in its Public Health programs.
- Assist DHSS with compliance with the Health Insurance Portability and Accountability Act and breach investigations.
- Assist DHSS with advice and representation in its Certificate of Need program.
- Assist DHSS with advice and representation in its Adult Protective Services program.
- Assist DHSS with advice and representation in its grant administration.
- Assist DHSS with tribal relations, including Tribal Health and the Alaska Child Welfare Compact.
- Represent the state in superior court proceedings seeking protective service for vulnerable individuals under AS 47.24 (adult protective services) and AS 47.30 (civil commitments).

Major Component Accomplishments in 2021

- Advised DHSS and the Governor's office with respect to the Disaster Declaration and Public Health Emergency related to COVID-19.
- Continued to provide legal services that directly protect public health and safety by prosecuting licensing actions related to facilities for those in need. The section advised state agencies in numerous investigations related to those licensed facilities, many that resulted in suspensions and/or revocations of the facilities' licenses, requiring administrative review.
- Continued to advise DHSS on various Health Insurance Portability and Accountability Act breaches as well as state and federal confidentiality laws.
- Continued to advise DHSS on the implementation of Senate Bill (SB) 74 Medicaid Reform (CH 25 SLA 2016), including the implementation of the 1115 Waiver to transform the behavioral health system in Alaska, which is estimated to save the state millions of general fund dollars in the coming fiscal years.
- Continued to advise DHSS on implementing changes to tribal Medicaid to assist in offsetting state general fund expenditures.
- Continued work on the Alaska Child Welfare Compact, which was formally signed by the Governor on October 19, 2017, by negotiating and drafting two funding agreements and confidentiality agreements and by working on implementation protocols.

- Worked daily with DHSS program staff on compliance issues, trainings, and other methods to reduce future litigation and to ensure constitutionally sufficient decisions and service delivery of all public assistance programs. This included representing state agencies in administrative hearings related to the reduction, termination, or denial of Medicaid services or benefits.
- Continued to work collaboratively with the Medicaid Fraud Control Unit and the Medicaid Program Integrity Unit to stop Medicaid fraud.
- Assisted DHSS in recovering Medicaid money through subrogation, estate recovery, trust recovery, and Medicaid audits of providers. This work includes legal representation in administrative hearings and superior court appeals. Since January 2019, the section has collected over two million dollars each calendar year through the Medicaid subrogation, estate and trust recovery claims, and the Medicaid audit process.
- Handled hundreds of hearings statewide related to guardianships, conservatorships and mental commitments (including contested evidentiary hearings, forced medication hearings and jury trials).
- Represented DHSS in civil litigation matters and contested administrative hearings related to programs administrated by DHSS.
- Assisted DHSS in the development and adoption of regulations to implement changes to generate general fund savings and efficiencies in various programs administered by DHSS.

Key Component Challenges

- The global COVID-19 pandemic has presented a sudden and unique set of challenges for the section, requiring section attorneys to research and advise on legal issues never before faced in Alaska, often on a very expedited timeline.
- Each fiscal year, the section handles an average of approximately 100 guardianship and conservatorship cases and over 200 mental commitment hearings statewide. The section advises DHSS on an equal number of cases that do not get to the petition or hearing stage. These cases involve some sort of court process, ranging from mediation/alternative dispute resolution to contested hearing and in some cases, jury trials.
- Attorney caseloads continue to increase each year, mainly because Alaska has one of the fastest growing aging populations in the nation.
- The section anticipates a significant increase in the number and complexity of regulation projects designed to assist in creating additional efficiencies in the administration of all DHSS programs. These projects are expected to generate litigation as changes to programs and funding streams are implemented in the coming fiscal year.
- Providing legal advice and support to DHSS on implementation of the 1115 Waiver.

Advise DHSS in the management and administration of API including:

- Continuing to work on Title 12 issues for persons who need forensic or restorative service when found to lack capacity to be charged criminally.
- Continuing to work on discharge planning for individuals who have been civilly committed. Due to the significant social, medical, mental health, or criminal history of some of these persons, finding community placement that addresses health, safety and welfare of both the recipient and the community is very difficult, which places demands on the section to provide continued legal representation in cases that would otherwise be closed.

Significant Changes in Results to be Delivered in FY2023

Continued issues related to the COVID-19 pandemic, implementation of the Medicaid reforms from SB 74, including tribal claiming and the 1115 Waiver for Behavioral Health and Substance Use Disorders; continuing advice about service and funding agreements under the State of Alaska Child Welfare Compact, and assisting API in maintaining

licensure and certification.

Statutory and Regulatory Authority

AS 44.23.020

Contact Information
<p>Contact: Stacie Kraly, Chief Assistant Attorney General Phone: (907) 465-3600 E-mail: stacie.kraly@alaska.gov</p>

Human Services Personal Services Information				
Authorized Positions			Personal Services Costs	
	<u>FY2022</u> <u>Management</u> <u>Plan</u>	<u>FY2023</u> <u>Governor</u>		
Full-time	21	21	Annual Salaries	2,012,588
Part-time	0	0	COLA	1,432
Nonpermanent	0	0	Premium Pay	0
			Annual Benefits	1,162,103
			<i>Less 4.42% Vacancy Factor</i>	<i>(140,423)</i>
			Lump Sum Premium Pay	0
Totals	21	21	Total Personal Services	3,035,700

Position Classification Summary					
Job Class Title	Anchorage	Fairbanks	Juneau	Others	Total
Attorney 3	0	0	1	0	1
Attorney 4	2	1	1	0	4
Attorney 5	3	0	2	0	5
Attorney 6	0	0	1	0	1
Law Office Assistant 1	2	0	1	0	3
Law Office Assistant 2	1	0	1	0	2
Paralegal 1	1	0	1	0	2
Paralegal 2	3	0	0	0	3
Totals	12	1	8	0	21

Component Detail All Funds
Department of Law

Component: Human Services (2962)
RDU: Civil Division (Excludes Janus) (35)

Non-Formula Component

	FY2021 Actuals	FY2022 Conference Committee	FY2022 Authorized	FY2022 Management Plan	FY2023 Governor	FY2022 Management Plan vs FY2023 Governor	
71000 Personal Services	2,710.8	3,112.2	3,112.2	3,112.2	3,035.7	-76.5	-2.5%
72000 Travel	6.1	21.9	21.9	21.9	21.9	0.0	0.0%
73000 Services	486.7	263.0	263.0	263.0	263.0	0.0	0.0%
74000 Commodities	39.3	39.6	39.6	39.6	39.6	0.0	0.0%
75000 Capital Outlay	10.9	0.0	0.0	0.0	0.0	0.0	0.0%
77000 Grants, Benefits	0.0	0.0	0.0	0.0	0.0	0.0	0.0%
78000 Miscellaneous	0.0	0.0	0.0	0.0	0.0	0.0	0.0%
Totals	3,253.8	3,436.7	3,436.7	3,436.7	3,360.2	-76.5	-2.2%
Fund Sources:							
1004 Gen Fund (UGF)	1,959.0	1,689.4	1,689.4	1,689.4	1,601.2	-88.2	-5.2%
1007 I/A Rcpts (Other)	1,294.8	1,647.2	1,647.2	1,647.2	1,658.9	11.7	0.7%
1037 GF/MH (UGF)	0.0	100.1	100.1	100.1	100.1	0.0	0.0%
Unrestricted General (UGF)	1,959.0	1,789.5	1,789.5	1,789.5	1,701.3	-88.2	-4.9%
Designated General (DGF)	0.0	0.0	0.0	0.0	0.0	0.0	0.0%
Other Funds	1,294.8	1,647.2	1,647.2	1,647.2	1,658.9	11.7	0.7%
Federal Funds	0.0	0.0	0.0	0.0	0.0	0.0	0.0%
Positions:							
Permanent Full Time	21	21	21	21	21	0	0.0%
Permanent Part Time	0	0	0	0	0	0	0.0%
Non Permanent	0	0	0	0	0	0	0.0%

Change Record Detail - Multiple Scenarios with Descriptions
Department of Law

Component: Human Services (2962)
RDU: Civil Division (Excludes Janus) (35)

Scenario/Change Record Title	Trans Type	Totals	Personal Services	Travel	Services	Commodities	Capital Outlay	Grants, Benefits	Miscellaneous	Positions		NP
										PFT	PPT	
***** Changes From FY2022 Conference Committee To FY2022 Authorized *****												
FY2022 Conference Committee												
	ConfCom	3,436.7	3,112.2	21.9	263.0	39.6	0.0	0.0	0.0	21	0	0
1004 Gen Fund		1,689.4										
1007 I/A Rcpts		1,647.2										
1037 GF/MH		100.1										
Subtotal		3,436.7	3,112.2	21.9	263.0	39.6	0.0	0.0	0.0	21	0	0
***** Changes From FY2022 Management Plan To FY2023 Governor *****												
FY2023 Salary and Benefit Adjustments												
	SalAdj	1.5	1.5	0.0	0.0	0.0	0.0	0.0	0.0	0	0	0
1004 Gen Fund		1.1										
1007 I/A Rcpts		0.4										
FY2023 SU BU - Supervisory Employees (SS) 1% COLA: \$1.5												
FY2023 Executive Health Insurance, SBS, and Risk Management Rate Changes												
	SalAdj	21.4	21.4	0.0	0.0	0.0	0.0	0.0	0.0	0	0	0
1004 Gen Fund		11.9										
1007 I/A Rcpts		9.5										
FY2023 Change Partially Exempt & Exempt Executive (EE) - Health Insurance from \$1,555 to \$1,685; SBS and Risk Management Rates: \$21.4												
FY2023 Supervisory Employees Health Insurance, SBS, and Risk Management Rate Changes												
	SalAdj	3.3	3.3	0.0	0.0	0.0	0.0	0.0	0.0	0	0	0
1004 Gen Fund		2.5										
1007 I/A Rcpts		0.8										
FY2023 Change Supervisory Employees (SS) - Health Insurance from \$1,555 to \$1,685; SBS and Risk Management Rates: \$3.3												
FY2023 General Government Unit SBS and Risk Management Rate Changes												
	SalAdj	1.2	1.2	0.0	0.0	0.0	0.0	0.0	0.0	0	0	0
1004 Gen Fund		0.5										
1007 I/A Rcpts		0.7										
FY2023 Change General Government Unit (GG, GP, GY, GZ) - SBS, and Risk Management Rates: \$1.2												
FY2023 PERS Actuarial Rate Adjustment to 24.79% Ch9 SLA2021 (SB55)												
	SalAdj	-103.9	-103.9	0.0	0.0	0.0	0.0	0.0	0.0	0	0	0
1004 Gen Fund		-56.5										

Change Record Detail - Multiple Scenarios with Descriptions
Department of Law

Component: Human Services (2962)
RDU: Civil Division (Excludes Janus) (35)

Scenario/Change Record Title	Trans Type	Totals	Personal Services	Travel	Services	Commodities	Capital Outlay	Grants, Benefits	Miscellaneous	Positions		NP
										PFT	PPT	
1007 I/A Rcpts		-47.4										
Includes: FY2023 Adjustment for PERS ARM Board Approved Rate of 24.79% (from 30.11%): \$-103.9												
Realign PERS Rate Adjustment by Fund Source Ch9 SLA2021 (SB55)												
	FndChg	0.0	0.0	0.0	0.0	0.0	0.0	0.0	0.0	0	0	0
1004 Gen Fund		-47.7										
1007 I/A Rcpts		47.7										
Remove one-time UGF subsidy for rate agency assigned in SB55 fiscal note (Ch 9 SLA 2021).												
Totals		3,360.2	3,035.7	21.9	263.0	39.6	0.0	0.0	0.0	21	0	0

Line Item Detail (1676)
Department of Law
Travel

Component: Human Services (2962)

Line Number	Line Name		FY2021 Actuals	FY2022 Management Plan	FY2023 Governor
2000	Travel		6.1	21.9	21.9
Object Class	Servicing Agency	Explanation	FY2021 Actuals	FY2022 Management Plan	FY2023 Governor
2000 Travel Detail Totals			6.1	21.9	21.9
2000	In-State Employee Travel	Travel for attorneys to interview witnesses and attend court proceedings, as well as for necessary training for both attorneys and paraprofessionals. Includes travel for management purposes.	0.0	12.0	12.0
2002	Out of State Employee Travel	Travel costs and expenses for out-of-state travel for conferences, training, etc.	0.0	2.9	2.9
2006	Other Travel Costs	Travel cost transfers.	6.1	7.0	7.0

Line Item Detail (1676)
Department of Law
Services

Component: Human Services (2962)

Line Number	Line Name		FY2021 Actuals	FY2022 Management Plan	FY2023 Governor
3000	Services		486.7	263.0	263.0
Object Class	Servicing Agency	Explanation	FY2021 Actuals	FY2022 Management Plan	FY2023 Governor
3000 Services Detail Totals			486.7	263.0	263.0
3000	Education Services	Conferences, training and memberships.	7.9	10.0	10.0
3002	Legal and Judicial Services	Depositions, research costs, expert witness and consultant fees.	37.7	40.0	40.0
3006	Delivery Services	Freight, courier, postage, and transportation of trial exhibit materials.	2.8	5.0	5.0
3011	Other Services	Cost transfers and miscellaneous items within the services line (commissions, etc.).	438.3	208.0	208.0

Line Item Detail (1676)
Department of Law
Commodities

Component: Human Services (2962)

Line Number	Line Name		FY2021 Actuals	FY2022 Management Plan	FY2023 Governor
4000	Commodities		39.3	39.6	39.6
Object Class	Servicing Agency	Explanation	FY2021 Actuals	FY2022 Management Plan	FY2023 Governor
4000 Commodities Detail Totals			39.3	39.6	39.6
4000	Business	Reference materials and subscriptions, including statutes, software applications, non-capital desktop refresh, and miscellaneous office supplies.	8.0	8.0	8.0
4022	Commodity Transfer	Commodity cost transfers.	31.3	31.6	31.6

Line Item Detail (1676)
Department of Law
Capital Outlay

Component: Human Services (2962)

Line Number	Line Name		FY2021 Actuals	FY2022 Management Plan	FY2023 Governor
5000	Capital Outlay		10.9	0.0	0.0
Object Class	Servicing Agency	Explanation	FY2021 Actuals	FY2022 Management Plan	FY2023 Governor
5000 Capital Outlay Detail Totals			10.9	0.0	0.0
5009	Capital Outlay Transfer	Capital cost transfers.	10.9	0.0	0.0

Revenue Detail (1681)
Department of Law

Component: Human Services (2962)

Revenue Type (OMB Fund Code) Revenue Source	Component	Comment	FY2021 Actuals	FY2022 Management Plan	FY2023 Governor
5007 I/A Rcpts (1007 I/A Rcpts)			1,294.8	1,647.2	1,658.9
5301 Inter-Agency Receipts	Health - Department-wide	RSA Health and Social Services, Medical Assistance Administration - legal services provided to the Division of Health Care Services, State Medicaid Program. Program code: CV03206555.	553.4	787.2	798.9
5301 Inter-Agency Receipts	Health - Department-wide	RSA Health and Social Services, Alaska Pioneer Homes - legal services. Program code: CV03206566.	10.9	50.0	50.0
5301 Inter-Agency Receipts	Health - Department-wide	RSA Health and Social Services, Medicaid Collections - legal services provided for the collection of Medicaid Liens, Provider Appeals and Special Needs Trust. Program code: CV03206569.	359.7	375.0	375.0
5301 Inter-Agency Receipts	Health - Department-wide	RSA Health and Social Services, Child Care Benefits - legal services provided for Child Care Licensing & Assistance. Program code: CV03206572.	4.0	10.0	10.0
5301 Inter-Agency Receipts	Health - Department-wide	RSA Health and Social Services, Alaska Psychiatric Institute - legal services to defend the hospital in litigation and coordinating expert testimony. Program code: CV03206573.	218.7	225.0	225.0
5301 Inter-Agency Receipts	Health - Department-wide	RSA Health and Social Services, Involuntary (Non-API) Mental Commitments - legal services. Program code: CV03206574.	62.2	75.0	75.0
5301 Inter-Agency Receipts	Health - Department-wide	RSA Health and Social Services, Department-wide legal services to support HIPAA compliance. Program code: CV03206661.	54.7	75.0	75.0

Revenue Detail (1681)
Department of Law

Component: Human Services (2962)

Revenue Type (OMB Fund Code)	Component	Comment	FY2021 Actuals	FY2022 Management Plan	FY2023 Governor
5301 Inter-Agency Receipts	Health - Department-wide	RSA Health and Social Services, Health Care Services - legal services for the residential licensing Medicaid program. Program code: CVHUS06001.	31.2	50.0	50.0

Personal Services Expenditure Detail
Department of Law

Scenario: FY2023 Governor (18673)
Component: Human Services (2962)
RDU: Civil Division (Excludes Janus) (35)

PCN	Job Class Title	Time Status	Retire Code	Barg Unit	Location	Salary Sched	Range / Step	Comp Months	Split / Count	Annual Salaries	COLA	Premium Pay	Annual Benefits	Total Costs	UGF Amount
03-0003	Attorney 6	FT	A	XE	Juneau	99	26O / P	12.0		157,745	0	0	78,289	236,034	118,017
03-0005	Attorney 5	FT	A	XE	Juneau	N05	25O	12.0		145,568	0	0	74,432	220,000	110,000
03-0006	Attorney 5	FT	A	XE	Anchorage	N00	25Q	12.0		147,771	0	0	75,187	222,958	55,740
03-0066	Attorney 4	FT	A	XE	Anchorage	N00	24M	12.0		120,978	0	0	65,277	186,255	18,626
03-0067	Law Office Assistant 2	FT	A	SS	Juneau	605	13C / D	12.0		53,456	734	0	40,283	94,473	94,473
03-0077	Law Office Assistant 1	FT	A	GP	Juneau	205	11K	12.0		51,422	0	0	37,926	89,348	89,348
03-0098	Paralegal 2	FT	A	GP	Anchorage	200	16K	12.0		69,381	0	0	44,612	113,993	39,898
03-0134	Attorney 4	FT	A	XE	Juneau	N05	24F	12.0		111,774	0	0	61,851	173,625	86,813
03-0162	Attorney 3	FT	A	XE	Juneau	N05	22J	12.0		100,796	0	0	57,764	158,560	31,712
03-0168	Law Office Assistant 1	FT	A	GP	Anchorage	200	11G / J	12.0		45,769	0	0	35,821	81,590	81,590
03-0183	Attorney 4	FT	A	XE	Anchorage	99	24N	12.0		126,118	0	0	67,191	193,309	96,655
03-0211	Law Office Assistant 1	FT	A	GP	Anchorage	200	11B / C	12.0		40,053	0	0	33,693	73,746	0
03-0281	Law Office Assistant 2	FT	A	SS	Anchorage	600	13C / D	12.0		50,864	698	0	39,318	90,880	45,440
03-0288	Paralegal 1	FT	A	GP	Anchorage	200	14B / C	12.0		47,461	0	0	36,451	83,912	0
03-0292	Paralegal 1	FT	A	GP	Juneau	205	14E / F	12.0		56,362	0	0	39,765	96,127	0
03-0366	Attorney 4	FT	A	XE	Fairbanks	N03	24L / M	12.0		124,115	0	0	66,445	190,560	142,920
03-0387	Paralegal 2	FT	A	GP	Anchorage	200	16J	12.0		67,197	0	0	43,799	110,996	110,996
03-0399	Paralegal 2	FT	A	GP	Anchorage	200	16N	12.0		76,362	0	0	47,211	123,573	0
03-0411	Attorney 5	FT	A	XE	Anchorage	N00	25Q	12.0		147,771	0	0	75,187	222,958	111,479
03-0414	Attorney 5	FT	A	XE	Anchorage	N00	25O / P	12.0		139,376	0	0	72,127	211,503	105,752
03-0418	Attorney 5	FT	A	XE	Juneau	N05	25L	12.0		132,249	0	0	69,474	201,723	201,723

	Total Positions	New	Deleted
Full Time Positions:	21	0	0
Part Time Positions:	0	0	0
Non Permanent Positions:	0	0	0
Positions in Component:	21	0	0

Total Salary Costs:	2,012,588
Total COLA:	1,432
Total Premium Pay:	0
Total Benefits:	1,162,103
Total Pre-Vacancy:	3,176,123
Minus Vacancy Adjustment of 4.42%:	(140,423)
Total Post-Vacancy:	3,035,700
Plus Lump Sum Premium Pay:	0
Personal Services Line 100:	3,035,700

Total Component Months: 252.0

PCN Funding Sources:	Pre-Vacancy	Post-Vacancy	Percent
1004 General Fund Receipts	1,541,179	1,473,040	48.52%
1007 Interagency Receipts	1,634,944	1,562,660	51.48%
Total PCN Funding:	3,176,123	3,035,700	100.00%

Note: If a position is split, an asterisk (*) will appear in the Split/Count column. If the split position is also counted in the component, two asterisks (**) will appear in this column. [No valid job title] appearing in the Job Class Title indicates that the PCN has an invalid class code or invalid range for the class code effective date of this scenario.

Personal Services Expenditure Detail
Department of Law

Scenario: FY2023 Governor (18673)
Component: Human Services (2962)
RDU: Civil Division (Excludes Janus) (35)

Note: If a position is split, an asterisk (*) will appear in the Split/Count column. If the split position is also counted in the component, two asterisks (**) will appear in this column.
[No valid job title] appearing in the Job Class Title indicates that the PCN has an invalid class code or invalid range for the class code effective date of this scenario.

CIVIL DIVISION

Human Services

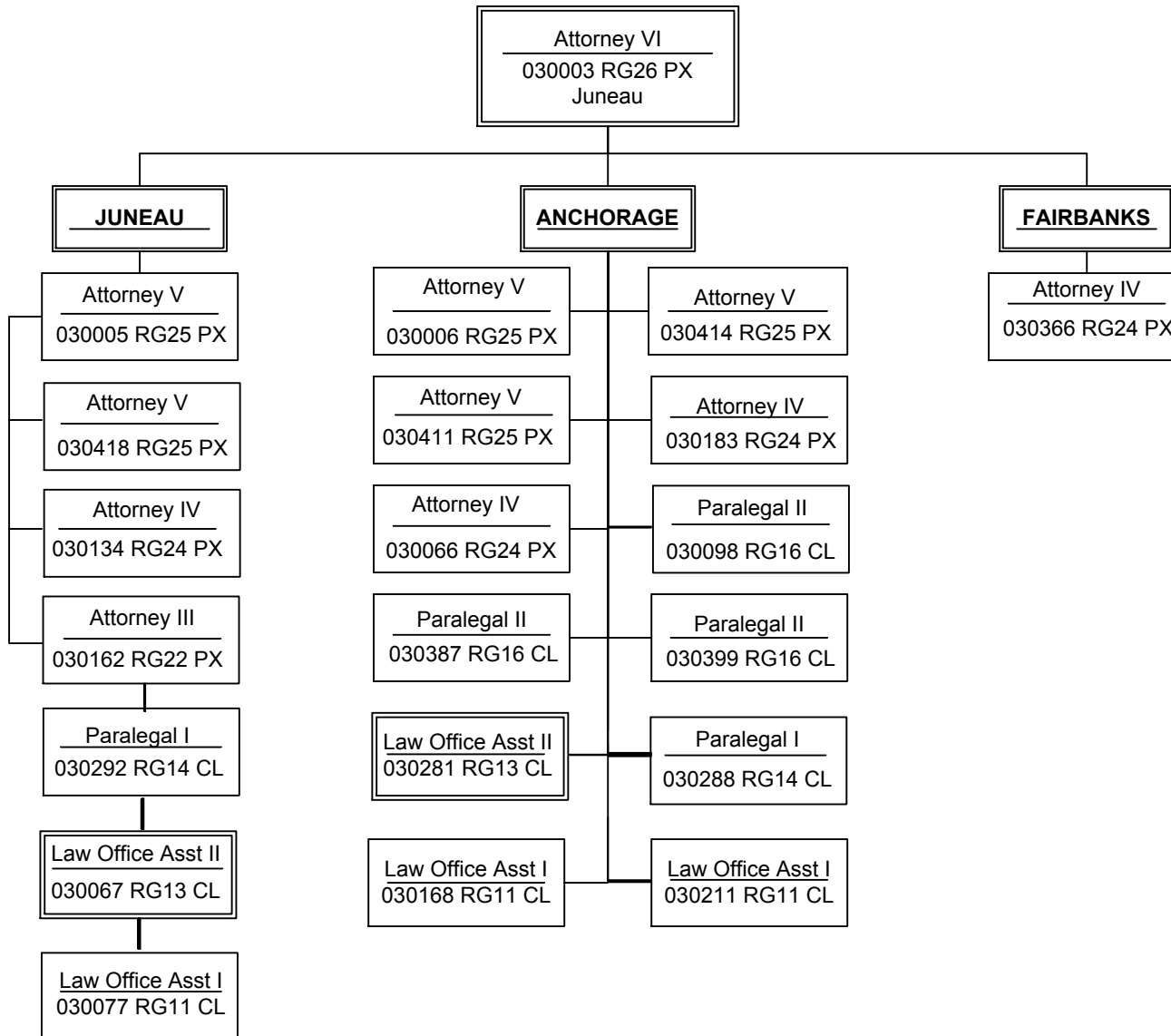

**State of Alaska
FY2023 Governor's Operating Budget**

**Department of Law
Labor and State Affairs
Component Budget Summary**

Component: Labor and State Affairs**Contribution to Department's Mission**

The Labor and State Affairs component provides advice and representation about management of state government, government finance, education, personnel, retirement and benefits, workforce, community and economic development, elections, and other government functions. Primary recipients of the legal services provided by this component include the Offices of the Governor and Lieutenant Governor; Departments of Administration, Education and Early Development, Revenue, Labor and Workforce Development, Commerce, Community, and Economic Development, Military and Veterans Affairs; the Alaska Court System; and quasi-government entities such as the Alaska Permanent Fund Corporation, Alaska Housing Finance Corporation, Alaska Retirement Management Board, Alaska Energy Authority, Alaska Industrial Development and Export Authority, Alaska Mental Health Trust Authority, Alaska Municipal Bond Bank Authority, Alaska Seafood Marketing Institute, and many boards and commissions, including the Alaska Public Offices Commission, Local Boundary Commission, and the Alaska State Commission on Human Rights.

Core Services

- Provide legal assistance needed for governmental and state public corporation management, including executive authority matters, personnel and labor relations issues, civil rights, public finance, procurement and contract claims, retirement and benefits programs, and homeland security.
- Provide legal assistance for problems associated with institutional relationships within state government, constitutionality of proposed legislation, separation of powers issues between the three branches of government, public corporations and boards and commissions, and interaction between the state and local governments and between the state and federal governments.
- Provide legal advice and representation on voter initiatives, the conduct of elections, campaign finance laws, education matters, public finance, economic development efforts, workers' compensation and unemployment insurance, occupational safety, wage and hour administration, employment programs, municipal grants, local boundary issues, and revocation of driver licenses.
- Provide legal advice to public corporations listed above.
- Represent the state, state officials, public corporations and state agencies in administrative hearings and in state and federal court litigation on all of the above issues.

Major Component Accomplishments in 2021

- Advised the Office of the Lieutenant Governor on issues, litigation, legislations and regulations stemming from the 2020 election cycle and implementation of the ranked choice voting initiative.
- Along with other attorneys in the department, advised the Office of the Governor, the Department of Administration, the Department of Commerce, Community, and Economic Development, the Department of Education and Early Development, the Office of Management and Budget, and other agencies on application of the Disaster Act and federal COVID-19 relief legislation during the pandemic and the distribution of federal funds to the state to mitigate impacts from the pandemic.
- Assisted the Alaska Industrial Development and Export Authority (AIDEA) in administration of the emergency small business relief program developed out of the state's Coronavirus relief funding. Assisted AIDEA in negotiating and drafting various loan guarantees and workouts relating to CARES Act funding and business disruptions resulting from the COVID pandemic; assisted with the liquidation of Mustang oil field assets; routinely assisted with negotiation and documentation of significant infrastructure loans. Assisted AIDEA on natural resource-related projects including issues related to the development of the Ambler Mining District industrial access road, West Susitna access road and Section 1002 Arctic National Wildlife Refuge.
- Advised Alaska Energy Authority on the purchase of a transmission line (Sterling to Quartz Creek, SQ line) and related assets from Homer Electric Association including the issuance of general obligation bonds and negotiating agreements with participating Railbelt utilities for the wheeling of power along the SQ line.

- Assisted the Alaska Housing Finance Corporation (AHFC) in responding to the housing crisis caused by the COVID-19 pandemic. Advised on the Alaska Housing Rent Relief program funded by federal relief funding, and on AHFC's implementation by contracting with 16 local governments and tribal entities to provide grants for rent and utility payments to affected tenants. The total federal funding for these programs has exceeded \$300 million and included payments to over seven percent of Alaska's population.
- Advised the Alaska Retirement Management Board regarding a variety of matters including litigation, review of complex investment documents (totaling tens of millions of dollars), and assistance in the adoption of self-directed brokerage account regulations.
- Advised the Alaska Municipal Bond Bank Authority and Department of Revenue on bond issuances and other public financing activities.
- Provided extensive legal advice and representation to the Department of Administration (DOA), Division of Retirement and Benefits, in numerous health and benefits appeals and coverage issues under the state's health care plans, and on proposed health and pension plan changes. Represented the division in significant and ongoing litigation that will further define the constitutional framework under which the state's retiree health plans must operate. Drafted complex contract agreements governing the third party administration of the retiree and employee health and dental plans, and assisted the division with the implementation of dual retiree dental plans, and modernization of the retiree medical plan.
- Drafted or reviewed a number of press releases, assisted with communication plans and talking points, and responded to media inquiries. Key public issues addressed in releases include the Department of Law's role in ongoing litigation on state sovereignty, criminal justice enforcement, separation-of-powers and other high-profile legal cases involving the State of Alaska and its officials.
- Provided legal advice and representation to DOA, the Department of Transportation and Public Facilities, and other state agencies on contracts, leasing and procurement, including advising state agencies on emergency procurement issues and contract enforcement issues in response to the Coronavirus and use of federal funds.
- Provided legal advice to the Local Boundary Commission on petitions for local boundary changes.
- Provided legal advice to the Office of Boards and Commissions on appointments and removal and the legislative confirmation process.
- Provided legal advice to DOA on personnel matters and defended the state in various administrative, trial, and appellate cases about personnel and employment matters, employment disputes, and labor law. Also advised on other legal issues relating to gubernatorial transition and boards and commissions appointments.
- Assisted DOA in labor relations strategy and negotiations for all of the union contracts completed this fiscal year.
- Represented the Department of Education and Early Development (DEED) in a multi-million-dollar case. The North Slope Borough challenged the department's decision to deny the borough reimbursement on a series of municipal bonds under the department's debt reimbursement program because the bonds failed to comply with statutory requirements. The Superior Court affirmed the department's decision and the borough appealed to the Alaska Supreme Court, which also affirmed the department's decision.
- Assisted DEED in addressing the impact of COVID-19 on the delivery of education in 2021 including the boundaries of suspension authority for education statutes and regulations and the coordination with federal emergency authority related to assessments and accountability. Assisted the department with various issues related to the federal statutory funding standards and the interpretation of existing state standards during the remote delivery of education, including issues related to student counts, instructional-hour requirements, and possible modification of the funding formula.

- Assisted Department of Commerce, Community and Economic Development (DCCED) on litigation associated with AK CARES grant funding. There have been multiple administrative appeals filed on decisions by DCCED to deny funding. The section continues to represent the agency in Superior Court.
- Assisted state agencies in responding to public records requests, which often involve extensive and time-consuming legal review of electronic records.
- Assisted state agencies in representing the state's interest in bankruptcy and creditor's rights issues including cases involving Ravn Air, SAExploration, and Alaskan Seismic Ventures as well as working with the DCCED regarding non-performing maritime loans and related bankruptcies.
- Advised and represented Division of Banking and Securities before courts and administrative tribunals in matters relating to consumer protection, voting proxy disputes, securities fraud, and banking and financial institution compliance.
- Assisted the Department of Labor and Workforce Development (DOL&WD) with unprecedented increase in unemployment insurance denial appeals as a result of COVID-19. Work included Rule 601 appellate practice and assisting the agency in production of the agency record in large cases.
- Reformed collections practice by increasing the use of self-populating forms for pleading, motions, and writ work, creating detailed outlines to preserve the section's institutional knowledge regarding the collections process, refining methods of serving documents, and identifying ways to effectively streamline the collections process overall.
- Continued to advise and represent DOL&WD, Alaska Occupational Safety and Health (AKOSH) during a period of increased employer contest cases. Settled numerous cases before hearing. Helped AKOSH revitalize its whistleblower program.

Key Component Challenges

- This component continues to operate under increased workloads and a lack of deep experience due to retirements and turnover. Recruitment continues to be difficult, producing only small pools of applicants and creating the need to advertise the position multiple times before a qualified candidate can be hired.
- The attorneys, who already had full workloads before the pandemic, found their workloads significantly increased with urgent assignments such as emergency regulations, health mandates, administrative orders, litigation and evaluating federal legislation, guidance and administrative responses to COVID-19. These higher workloads are likely to continue in light of the ongoing pandemic.
- There has been an increasing amount of work to address technical labor relations issues. Workflow has increased significantly and will continue to increase as we advise DOA and the Governor's Office on personnel and collective bargaining questions.
- It is expected that attorneys will continue to handle a large amount of legal work related to the economic effects of COVID-19 and the state's efforts to provide for economic development including legal assistance to public corporations tasked with economic development as well as state agencies involved in the management of state funds.
- Attorneys will continue working with DOA in defending appeals and litigation filed against the state's active and retiree health and benefit plans; assisting the Division of Retirement and Benefits with responses to questions about proposed changes to the various health and pension plans; and advising on any future legislative changes to the state's health and benefit plans and on health care-related questions related to the state's collective bargaining agreements.
- This component will continue to advise the Local Boundary Commission on petitions for boundary changes. Boundary change matters are complex, require precision, and involve significant legal evaluation, thus requiring dedication of significant attorney time.

- Attorneys will continue to advise the Office of the Lieutenant Governor and the Division of Elections in elections matters, and to litigate elections-related challenges in both state and federal court. This work has also increased even more following the 2020 election year due to a myriad of lawsuits challenging various aspects of the election process, the passage of the ranked choice voting initiative, and increased focus by the public, media, and lawmakers on various aspects of the elections process.
- Attorneys will continue to handle a large volume of legal work related to the solicitation, negotiation and review of contracts, procurement protests, and contract claims for professional services, supplies, and leasing.
- Significant aid-to-agency advice for DEED and the State Board of Education will be required on matters ranging from budget issues, school construction financing, accountability and accreditation standards, and various other issues. The section will also continue to provide representation for the Alaska Student Loan Corporation and the Alaska Commission on Post-Secondary Education.
- Attorneys will devote significant time to assisting agencies with increasing requests for new regulations projects and on legislative-related issues.
- It is expected that significant resources may be applied to handling unemployment insurance appeals due to COVID.
- The component's success in modernizing collections has resulted in increased requests by existing and potential clients to pursue additional collections actions.

Significant Changes in Results to be Delivered in FY2023

State agencies need ongoing legal advice relating to the COVID-19 pandemic including its impact on the state and state agencies, on drafting legislation, implementing programs and enforcement mandates in times of reduced revenues and a global pandemic, and addressing ongoing funding, health care, education, and labor and employment issues. This component provides legal advice on these and other issues, including matters related to public corporations, boards and commissions, the Division of Elections, the Office of the Governor and DOA. Given the current economic outlook, client needs in these areas are expected to remain high in FY2023.

The section also expects a continuing flow of retirement and benefits appeals, healthcare- and pension-related legal questions, education advice matters, casework for the DOL&WD (particularly in the area of AKOSH and Unemployment Insurance actions), and the Department of Military and Veterans Affairs matters.

Statutory and Regulatory Authority

AS 44.23.020

Contact Information
Contact: Rachel Witty, Chief Assistant Attorney General Phone: (907) 269-5100 E-mail: rachel.witty@alaska.gov

Labor and State Affairs Personal Services Information				
Authorized Positions			Personal Services Costs	
	<u>FY2022</u> <u>Management</u> <u>Plan</u>	<u>FY2023</u> <u>Governor</u>		
Full-time	22	22	Annual Salaries	2,390,318
Part-time	0	0	COLA	752
Nonpermanent	0	0	Premium Pay	0
			Annual Benefits	1,319,677
			<i>Less 2.45% Vacancy Factor</i>	<i>(90,747)</i>
			Lump Sum Premium Pay	0
Totals	22	22	Total Personal Services	3,620,000

Position Classification Summary					
Job Class Title	Anchorage	Fairbanks	Juneau	Others	Total
Associate Attorney 2	1	0	0	0	1
Attorney 3	1	0	0	0	1
Attorney 4	5	0	2	0	7
Attorney 5	2	0	5	0	7
Attorney 6	1	0	1	0	2
Division Director - Px	0	0	1	0	1
Law Office Assistant 1	1	0	0	0	1
Law Office Assistant 2	1	0	0	0	1
Paralegal 1	0	0	1	0	1
Totals	12	0	10	0	22

Component Detail All Funds
Department of Law

Component: Labor and State Affairs (2718)
RDU: Civil Division (Excludes Janus) (35)

Non-Formula Component

	FY2021 Actuals	FY2022 Conference Committee	FY2022 Authorized	FY2022 Management Plan	FY2023 Governor	FY2022 Management Plan vs FY2023 Governor	
71000 Personal Services	4,432.0	3,849.2	3,849.2	3,708.1	3,620.0	-88.1	-2.4%
72000 Travel	11.0	25.7	25.7	25.7	25.7	0.0	0.0%
73000 Services	2,471.7	904.0	904.0	904.0	904.0	0.0	0.0%
74000 Commodities	47.1	60.5	60.5	60.5	60.5	0.0	0.0%
75000 Capital Outlay	16.3	0.0	0.0	0.0	0.0	0.0	0.0%
77000 Grants, Benefits	0.0	0.0	0.0	0.0	0.0	0.0	0.0%
78000 Miscellaneous	0.0	0.0	0.0	0.0	0.0	0.0	0.0%
Totals	6,978.1	4,839.4	4,839.4	4,698.3	4,610.2	-88.1	-1.9%
Fund Sources:							
1004 Gen Fund (UGF)	4,082.7	1,670.8	1,670.8	1,600.2	1,488.9	-111.3	-7.0%
1007 I/A Rcpts (Other)	2,895.4	2,968.6	2,968.6	2,898.1	2,921.3	23.2	0.8%
1061 CIP Rcpts (Other)	0.0	200.0	200.0	200.0	200.0	0.0	0.0%
Unrestricted General (UGF)	4,082.7	1,670.8	1,670.8	1,600.2	1,488.9	-111.3	-7.0%
Designated General (DGF)	0.0	0.0	0.0	0.0	0.0	0.0	0.0%
Other Funds	2,895.4	3,168.6	3,168.6	3,098.1	3,121.3	23.2	0.7%
Federal Funds	0.0	0.0	0.0	0.0	0.0	0.0	0.0%
Positions:							
Permanent Full Time	22	23	23	22	22	0	0.0%
Permanent Part Time	0	0	0	0	0	0	0.0%
Non Permanent	0	0	0	0	0	0	0.0%

Change Record Detail - Multiple Scenarios with Descriptions
Department of Law

Component: Labor and State Affairs (2718)
RDU: Civil Division (Excludes Janus) (35)

Scenario/Change Record Title	Trans Type	Totals	Personal Services	Travel	Services	Commodities	Capital Outlay	Grants, Benefits	Miscellaneous	Positions		NP
										PFT	PPT	
***** Changes From FY2022 Conference Committee To FY2022 Authorized *****												
FY2022 Conference Committee												
	ConfCom	4,839.4	3,849.2	25.7	904.0	60.5	0.0	0.0	0.0	23	0	0
1004 Gen Fund		1,670.8										
1007 I/A Rcpts		2,968.6										
1061 CIP Rcpts		200.0										
Subtotal		4,839.4	3,849.2	25.7	904.0	60.5	0.0	0.0	0.0	23	0	0
***** Changes From FY2022 Authorized To FY2022 Management Plan *****												
Transfer Paralegal 1 (03-0397) from Torts and Workers' Compensation to Address Workload Demands												
	Trin	0.0	0.0	0.0	0.0	0.0	0.0	0.0	0.0	1	0	0
Transfer a full-time Paralegal 1 (03-0397), range 14, located in Juneau, to the Labor and State Affairs component from the Torts and Workers' Compensation component to accommodate workload demands. The remaining staff in Torts and Workers' Compensation are sufficient to cover the anticipated workload.												
Transfer Law Office Assistant 1 (03-0083) to Natural Resources to Address Workload Demands												
	Trout	0.0	0.0	0.0	0.0	0.0	0.0	0.0	0.0	-1	0	0
Transfer a full-time Law Office Assistant 1 (03-0083), range 11, located in Juneau, to the Natural Resources component from the Labor and State Affairs component to accommodate workload demands. The remaining staff in Labor and State Affairs are sufficient to cover the anticipated workload.												
Transfer Attorney 3 (03-0243) to Legislation/Regulations for Required Legal Expertise												
	Trout	-141.1	-141.1	0.0	0.0	0.0	0.0	0.0	0.0	-1	0	0
1004 Gen Fund		-70.6										
1007 I/A Rcpts		-70.5										
Transfer one full-time Attorney 3 position (03-0243), range 22, located in Anchorage, to the Legislation/Regulations component from the Labor and State Affairs component to keep pace with the required level of legal expertise needed within the office. The remaining staff in Labor and State Affairs are sufficient to accommodate anticipated workload.												
Subtotal		4,698.3	3,708.1	25.7	904.0	60.5	0.0	0.0	0.0	22	0	0
***** Changes From FY2022 Management Plan To FY2023 Governor *****												
FY2023 Salary and Benefit Adjustments												
	SalAdj	0.8	0.8	0.0	0.0	0.0	0.0	0.0	0.0	0	0	0
1004 Gen Fund		0.4										
1007 I/A Rcpts		0.4										
FY2023 SU BU - Supervisory Employees (SS) 1% COLA: \$0.8												

Change Record Detail - Multiple Scenarios with Descriptions
Department of Law

Component: Labor and State Affairs (2718)
RDU: Civil Division (Excludes Janus) (35)

Scenario/Change Record Title	Trans Type	Totals	Personal Services	Travel	Services	Commodities	Capital Outlay	Grants, Benefits	Miscellaneous	Positions		NP
										PFT	PPT	
FY2023 Executive Health Insurance, SBS, and Risk Management Rate Changes												
	SalAdj	35.5	35.5	0.0	0.0	0.0	0.0	0.0	0.0	0	0	0
1004 Gen Fund		13.6										
1007 I/A Rcpts		21.9										
FY2023 Change Partially Exempt & Exempt Executive (EE) - Health Insurance from \$1,555 to \$1,685; SBS and Risk Management Rates: \$35.5												
FY2023 Supervisory Employees Health Insurance, SBS, and Risk Management Rate Changes												
	SalAdj	1.7	1.7	0.0	0.0	0.0	0.0	0.0	0.0	0	0	0
1004 Gen Fund		0.9										
1007 I/A Rcpts		0.8										
FY2023 Change Supervisory Employees (SS) - Health Insurance from \$1,555 to \$1,685; SBS and Risk Management Rates: \$1.7												
FY2023 General Government Unit SBS and Risk Management Rate Changes												
	SalAdj	0.3	0.3	0.0	0.0	0.0	0.0	0.0	0.0	0	0	0
1004 Gen Fund		0.2										
1007 I/A Rcpts		0.1										
FY2023 Change General Government Unit (GG, GP, GY, GZ) - SBS, and Risk Management Rates: \$0.3												
FY2023 PERS Actuarial Rate Adjustment to 24.79% Ch9 SLA2021 (SB55)												
	SalAdj	-126.4	-126.4	0.0	0.0	0.0	0.0	0.0	0.0	0	0	0
1004 Gen Fund		-51.3										
1007 I/A Rcpts		-75.1										
Includes: FY2023 Adjustment for PERS ARM Board Approved Rate of 24.79% (from 30.11%): \$-126.4												
Realign PERS Rate Adjustment by Fund Source Ch9 SLA2021 (SB55)												
	FndChg	0.0	0.0	0.0	0.0	0.0	0.0	0.0	0.0	0	0	0
1004 Gen Fund		-75.1										
1007 I/A Rcpts		75.1										
Remove one-time UGF subsidy for rate agency assigned in SB55 fiscal note (Ch 9 SLA 2021).												
Totals		4,610.2	3,620.0	25.7	904.0	60.5	0.0	0.0	0.0	22	0	0

Line Item Detail (1676)
Department of Law
Travel

Component: Labor and State Affairs (2718)

Line Number	Line Name		FY2021 Actuals	FY2022 Management Plan	FY2023 Governor
2000	Travel		11.0	25.7	25.7
Object Class	Servicing Agency	Explanation	FY2021 Actuals	FY2022 Management Plan	FY2023 Governor
2000 Travel Detail Totals			11.0	25.7	25.7
2000	In-State Employee Travel	Travel for attorneys to interview witnesses and attend court proceedings, as well as for necessary training for both attorneys and paraprofessionals. Includes travel for management purposes.	1.8	15.0	15.0
2001	In-State Non-Employee Travel	Travel costs for witnesses to testify in court.	0.0	5.0	5.0
2002	Out of State Employee Travel	Travel costs and expenses for out-of-state travel for conferences, training, etc.	0.0	2.0	2.0
2006	Other Travel Costs	Travel cost transfers.	9.2	3.7	3.7

Line Item Detail (1676)
Department of Law
Services

Component: Labor and State Affairs (2718)

Line Number	Line Name		FY2021 Actuals	FY2022 Management Plan	FY2023 Governor
3000	Services		2,471.7	904.0	904.0
Object Class	Servicing Agency	Explanation	FY2021 Actuals	FY2022 Management Plan	FY2023 Governor
3000 Services Detail Totals			2,471.7	904.0	904.0
3000	Education Services	Conferences, training and memberships.	12.5	12.5	12.5
3002	Legal and Judicial Services	Depositions, research costs, expert witness and consultant fees.	1,752.0	841.1	841.1
3003	Information Technology	Training, consulting and software licensing and maintenance. Annual maintenance fee for mission-critical information management systems.	0.1	1.0	1.0
3004	Telecommunications	Local telephone service, long distance charges and cellular phone services paid to third-party telephone utilities.	0.2	0.2	0.2
3006	Delivery Services	Freight, courier, postage, and transportation of trial exhibit materials.	5.2	5.0	5.0
3011	Other Services	Cost transfers and miscellaneous items within the services line (commissions, etc.).	658.7	0.0	0.0
3013	Inter-Agency Data Processing Operations Allocation	Law - Administrative Services (2164) RSA Law, Information services, data processing investments and support.	1.5	1.5	1.5
3017	Inter-Agency Information Technology Non-Telecommunications	Admin - Department-wide RSA Administration, Office of Information Technology computer services.	16.0	16.0	16.0
3018	Inter-Agency Information Technology Telecommunications	Admin - Department-wide RSA Administration, Office of Information Technology telecommunications services.	2.1	2.1	2.1
3021	Inter-Agency Mail	RSA Administration, Central Mail.	0.3	0.3	0.3

Line Item Detail (1676)
Department of Law
Services

Component: Labor and State Affairs (2718)

Object Class		Servicing Agency	Explanation	FY2021 Actuals	FY2022 Management Plan	FY2023 Governor
3000 Services Detail Totals				2,471.7	904.0	904.0
3022	Inter-Agency Human Resources	Law - Administrative Services (2164)	RSA Law, Human Resources position.	3.7	3.7	3.7
3023	Inter-Agency Building Leases	Admin - Department-wide	Leased office space managed by General Services.	18.8	20.0	20.0
3026	Inter-Agency Insurance	Admin - Department-wide	RSA Administration, Risk Management.	0.3	0.3	0.3
3027	Inter-Agency Financial	Admin - Department-wide	RSA Administration, Finance Chargeback (IRIS).	0.3	0.3	0.3

Line Item Detail (1676)
Department of Law
Commodities

Component: Labor and State Affairs (2718)

Line Number	Line Name		FY2021 Actuals	FY2022 Management Plan	FY2023 Governor
4000	Commodities		47.1	60.5	60.5
Object Class	Servicing Agency	Explanation	FY2021 Actuals	FY2022 Management Plan	FY2023 Governor
4000 Commodities Detail Totals			47.1	60.5	60.5
4000	Business	Reference materials and subscriptions, including statutes, software applications, non-capital desktop refresh, and miscellaneous office supplies.	0.0	2.0	2.0
4022	Commodity Transfer	Commodity cost transfers.	47.1	58.5	58.5

Line Item Detail (1676)
Department of Law
Capital Outlay

Component: Labor and State Affairs (2718)

Line Number	Line Name		FY2021 Actuals	FY2022 Management Plan	FY2023 Governor
5000	Capital Outlay		16.3	0.0	0.0
Object Class	Servicing Agency	Explanation	FY2021 Actuals	FY2022 Management Plan	FY2023 Governor
5000 Capital Outlay Detail Totals			16.3	0.0	0.0
5009	Capital Outlay Transfer	Capital cost transfers.	16.3	0.0	0.0

Revenue Detail (1681)
Department of Law

Component: Labor and State Affairs (2718)

Revenue Type (OMB Fund Code) Revenue Source	Component	Comment	FY2021 Actuals	FY2022 Management Plan	FY2023 Governor
5007 I/A Rcpts (1007 I/A Rcpts)			2,895.8	2,898.1	2,921.3
5301 Inter-Agency Receipts	Admin - Department-wide	RSA Administration, Division of Motor Vehicles - legal services. Program code: CV03207570.	20.0	50.5	55.0
5301 Inter-Agency Receipts	Commerce - Department-wide	RSA Commerce, Division of Community & Regional Affairs - legal services. Program code: CV03207533.	29.2	30.0	30.0
5301 Inter-Agency Receipts	Courts - Department-wide	RSA Alaska Court System - legal services. Program code: CV03207641.	22.4	25.0	30.0
5301 Inter-Agency Receipts	E&ED - Department-wide	RSA Education, Every Student Succeeds Act - outside counsel legal services. Program code: CV03207636.	0.2	20.0	20.0
5301 Inter-Agency Receipts	Labor - Department-wide	RSA Labor, Labor Standards & Safety - legal services. Program code: CV03207516.	279.5	300.0	300.0
5301 Inter-Agency Receipts	M&VA - Department-wide	RSA Military and Veterans Affairs, Commissioner's Office - legal services. Program code: CV03207677.	9.5	10.0	15.0
5301 Inter-Agency Receipts	Rev - Department-wide	RSA Revenue, Alaska Retirement Management Board - outside counsel legal services. Program code: CV03207521.	0.2	1.0	1.0
5301 Inter-Agency Receipts	Admin - Department-wide	RSA Administration, Division of Retirement and Benefits - legal services. Program code: CV03207535.	465.8	500.0	500.0
5301 Inter-Agency Receipts	Commerce - Department-wide	RSA Commerce, Alaska Industrial Development and Export Authority - legal services. Program code: CV03207550.	318.5	320.0	320.0
5301 Inter-Agency Receipts	E&ED - Department-wide	RSA Education, IDEA Legal Assistance - outside counsel legal	15.0	25.0	25.0

Revenue Detail (1681)
Department of Law

Component: Labor and State Affairs (2718)

Revenue Type (OMB Fund Code) Revenue Source	Component	Comment	FY2021 Actuals	FY2022 Management Plan	FY2023 Governor
5301 Inter-Agency Receipts	Labor - Department-wide	services. Program code: CV03207602. RSA Labor, Employment and Training Services Division - Unemployment Insurance legal services. Program code: CV03207544.	47.2	50.0	50.0
5301 Inter-Agency Receipts	Rev - Department-wide	RSA Revenue, Alaska Retirement Management Board - legal services. Program code: CV03207522.	46.5	50.0	50.0
5301 Inter-Agency Receipts	Admin - Department-wide	RSA Administration, Division of Retirement and Benefits - outside counsel legal services. Program code: CV03207604.	63.7	75.0	75.0
5301 Inter-Agency Receipts	Commerce - Department-wide	RSA Commerce, Alaska Energy Authority - outside counsel legal services. Program code: CV03207578.	1.3	25.0	25.0
5301 Inter-Agency Receipts	E&ED - Department-wide	RSA Education, Department-wide legal services. Program code: CV03207554.	350.0	400.0	400.0
5301 Inter-Agency Receipts	Labor - Department-wide	RSA Labor, Workers' Compensation Division - legal services. Program code: CV03207584.	73.2	75.0	75.0
5301 Inter-Agency Receipts	Rev - Department-wide	RSA Revenue, Alaska Municipal Bond Bank Authority - outside counsel legal services. Program code: CV03207692.	122.5	125.0	125.0
5301 Inter-Agency Receipts	Commerce - Department-wide	RSA Commerce, Alaska Seafood Marketing Institute - legal services. Program code: CV03207585.	10.3	15.0	15.0
5301 Inter-Agency Receipts	Labor - Department-wide	RSA Labor, Workers' Compensation Division - Workers' Compensation Guaranty Fund legal services. Program code: CV03207657.	103.9	105.0	105.0

Revenue Detail (1681)
Department of Law

Component: Labor and State Affairs (2718)

Revenue Type (OMB Fund Code) Revenue Source	Component	Comment	FY2021 Actuals	FY2022 Management Plan	FY2023 Governor
5301 Inter-Agency Receipts	Rev - Department-wide	RSA Revenue, Alaska Permanent Fund Corporation - legal services. Program code: CV03207523.	1.3	1.5	5.0
5301 Inter-Agency Receipts	Commerce - Department-wide	RSA Commerce, Alaska Seafood Marketing Institute - outside counsel legal services regarding trademark law. Program code: CV03207638.	25.4	55.0	55.0
5301 Inter-Agency Receipts	Labor - Department-wide	RSA Labor, Vocational Rehabilitation - legal services. Program code: CV03207580.	2.3	15.0	20.0
5301 Inter-Agency Receipts	Rev - Department-wide	RSA Revenue, Alaska State Bond Committee - legal services. Program code: CV03207695.	25.0	25.0	25.0
5301 Inter-Agency Receipts	Commerce - Department-wide	RSA Commerce, Alaska Industrial Development and Export Authority - outside counsel legal services. Program code: CV03207690.	771.9	500.1	500.3
5301 Inter-Agency Receipts	Commerce - Department-wide	RSA Commerce, Alaska Energy Authority - legal services. Program code: CV03207545.	91.0	100.0	100.0
5061 CIP Rcpts (1061 CIP Rcpts)			0.0	200.0	200.0
5351 Capital Improvement Project Inter-Agency		Receipts from capital projects	0.0	200.0	200.0

Inter-Agency Services (1682)
Department of Law

Component: Labor and State Affairs (2718)

				FY2021 Actuals	FY2022 Management Plan	FY2023 Governor
Component Totals				42.7	43.9	43.9
With Department of Law				5.2	5.2	5.2
With Department of Administration				37.5	38.7	38.7
Object Class	Servicing Agency	Explanation		FY2021 Actuals	FY2022 Management Plan	FY2023 Governor
3013	Inter-Agency Data Processing Operations Allocation	Law - Administrative Services (2164)	RSA Law, Information services, data processing investments and support.	1.5	1.5	1.5
3017	Inter-Agency Information Technology Non-Telecommunications	Admin - Department-wide	RSA Administration, Office of Information Technology computer services.	16.0	16.0	16.0
3018	Inter-Agency Information Technology Telecommunications	Admin - Department-wide	RSA Administration, Office of Information Technology telecommunications services.	2.1	2.1	2.1
3022	Inter-Agency Human Resources	Law - Administrative Services (2164)	RSA Law, Human Resources position.	3.7	3.7	3.7
3023	Inter-Agency Building Leases	Admin - Department-wide	Leased office space managed by General Services.	18.8	20.0	20.0
3026	Inter-Agency Insurance	Admin - Department-wide	RSA Administration, Risk Management.	0.3	0.3	0.3
3027	Inter-Agency Financial	Admin - Department-wide	RSA Administration, Finance Chargeback (IRIS).	0.3	0.3	0.3

Personal Services Expenditure Detail
Department of Law

Scenario: FY2023 Governor (18673)
Component: Labor and State Affairs (2718)
RDU: Civil Division (Excludes Janus) (35)

PCN	Job Class Title	Time Status	Retire Code	Barg Unit	Location	Salary Sched	Range / Step	Comp Months	Split / Count	Annual Salaries	COLA	Premium Pay	Annual Benefits	Total Costs	UGF Amount
03-0028	Division Director - Px	FT	A	XE	Juneau	N05	27R	12.0		172,224	0	0	82,792	255,016	127,508
03-0029	Attorney 5	FT	A	XE	Anchorage	N00	25K	12.0		121,973	0	0	65,648	187,621	93,811
03-0039	Attorney 6	FT	A	XE	Anchorage	N00	26Q / R	12.0		155,113	0	0	77,470	232,583	174,437
03-0047	Attorney 4	FT	A	XE	Anchorage	N00	24E / F	12.0		104,744	0	0	59,233	163,977	109,865
03-0049	Law Office Assistant 1	FT	A	GP	Anchorage	200	11D / E	12.0		42,378	0	0	34,559	76,937	76,937
03-0097	Attorney 5	FT	A	XE	Juneau	N05	25N / O	12.0		142,231	0	0	73,190	215,421	183,108
03-0133	Attorney 4	FT	A	XE	Juneau	N05	24E / F	12.0		108,705	0	0	60,708	169,413	0
03-0174	Attorney 6	FT	A	XE	Juneau	N05	26J / K	12.0		131,966	0	0	69,368	201,334	50,334
03-0289	Attorney 4	FT	A	XE	Juneau	N05	24F	12.0		111,774	0	0	61,851	173,625	0
03-0291	Attorney 4	FT	A	XE	Anchorage	N00	24F / J	12.0		109,327	0	0	60,940	170,267	0
03-0293	Attorney 3	FT	A	XE	Anchorage	N00	22D / E	12.0		89,224	0	0	53,455	142,679	0
03-0302	Attorney 5	FT	A	XE	Juneau	N05	25F	12.0		120,140	0	0	64,965	185,105	185,105
03-0309	Attorney 5	FT	A	XE	Juneau	99	25Q	12.0		154,714	0	0	77,346	232,060	46,412
03-0318	Law Office Assistant 2	FT	A	SS	Anchorage	600	13F / J	12.0		54,789	752	0	40,779	96,320	48,160
03-0319	Attorney 4	FT	A	XE	Anchorage	N00	24J / K	12.0		111,995	0	0	61,933	173,928	113,053
03-0344	Attorney 4	FT	A	XE	Anchorage	N00	24A / B	12.0		91,482	0	0	54,296	145,778	0
03-0357	Attorney 4	FT	A	XE	Anchorage	N00	24J	12.0		109,902	0	0	61,154	171,056	25,658
03-0378	Attorney 5	FT	A	XE	Juneau	N05	25F / J	12.0		122,090	0	0	65,691	187,781	93,891
03-0392	Associate Attorney 2	FT	A	XE	Anchorage	N00	19M	6.0	**	43,407	0	0	26,279	69,686	45,296
03-0397	Paralegal 1	FT	A	GP	Juneau	205	14A / B	12.0		48,565	0	0	36,862	85,427	0
03-0416	Attorney 5	FT	A	XE	Anchorage	N00	25K	12.0		121,973	0	0	65,648	187,621	28,143
03-0426	Attorney 5	FT	A	XE	Juneau	N05	25F / J	12.0		121,602	0	0	65,510	187,112	0
													Total Salary Costs:	2,390,318	
													Total COLA:	752	
													Total Premium Pay:	0	
													Total Benefits:	1,319,677	
													Total Pre-Vacancy:	3,710,747	
													Minus Vacancy Adjustment of 2.45%:	(90,747)	
													Total Post-Vacancy:	3,620,000	
													Plus Lump Sum Premium Pay:	0	
													Personal Services Line 100:	3,620,000	
Total Component Months:		258.0													
Positions			New	Deleted											
Full Time Positions:		22	0	0											
Part Time Positions:		0	0	0											
Non Permanent Positions:		0	0	0											
Positions in Component:		22	0	0											

Note: If a position is split, an asterisk (*) will appear in the Split/Count column. If the split position is also counted in the component, two asterisks (**) will appear in this column. [No valid job title] appearing in the Job Class Title indicates that the PCN has an invalid class code or invalid range for the class code effective date of this scenario.

Personal Services Expenditure Detail
Department of Law

Scenario: FY2023 Governor (18673)
Component: Labor and State Affairs (2718)
RDU: Civil Division (Excludes Janus) (35)

PCN Funding Sources:	Pre-Vacancy	Post-Vacancy	Percent
1004 General Fund Receipts	1,401,717	1,367,438	37.77%
1007 Interagency Receipts	2,309,030	2,252,562	62.23%
Total PCN Funding:	3,710,747	3,620,000	100.00%

Note: If a position is split, an asterisk (*) will appear in the Split/Count column. If the split position is also counted in the component, two asterisks (**) will appear in this column.
[No valid job title] appearing in the Job Class Title indicates that the PCN has an invalid class code or invalid range for the class code effective date of this scenario.

CIVIL DIVISION

Labor and State Affairs

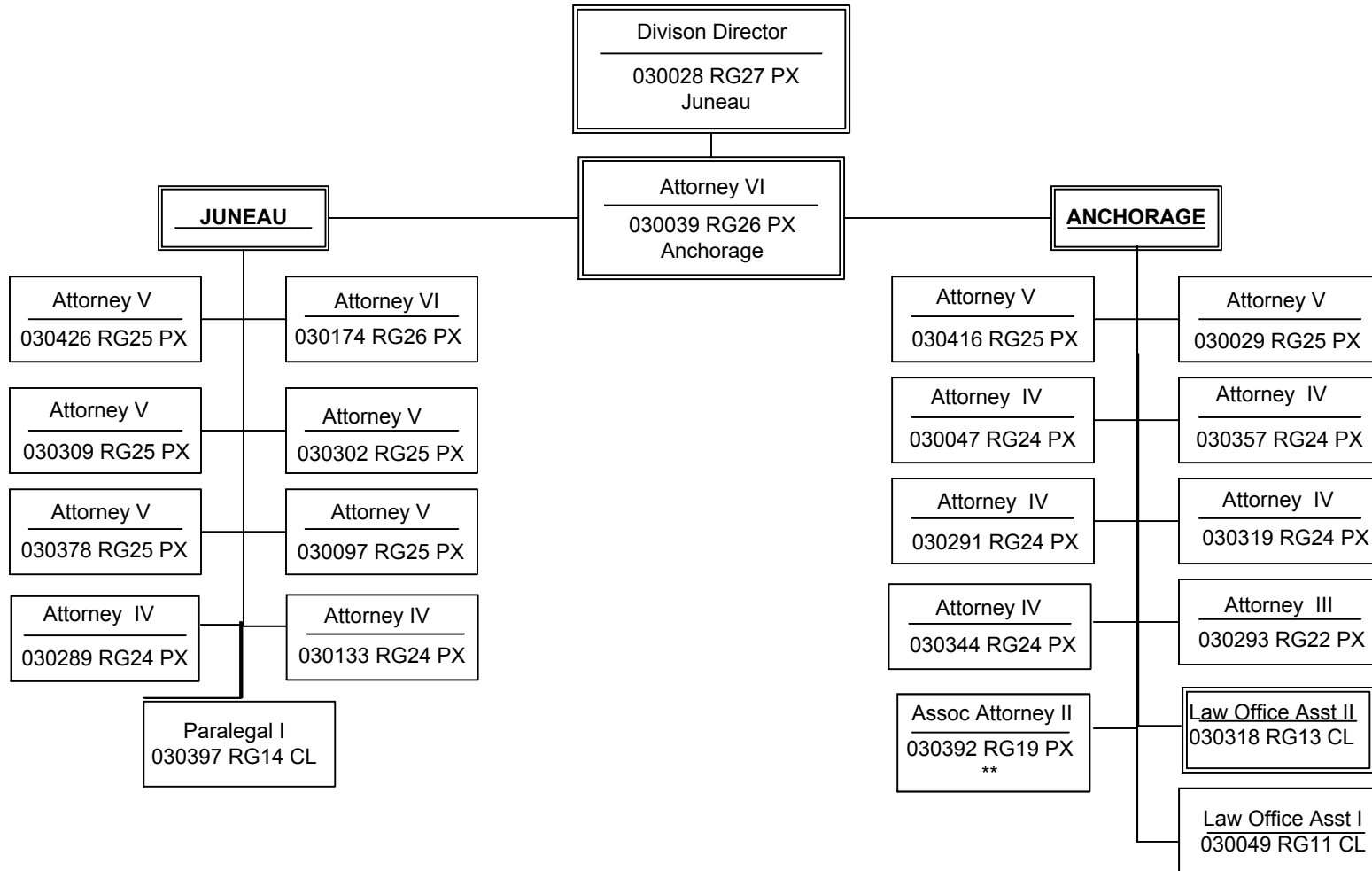

State of Alaska FY2023 Governor's Operating Budget

Department of Law Legislation/Regulations Component Budget Summary

Component: Legislation/Regulations**Contribution to Department's Mission**

The Legislation and Regulations Section provides legal advice to executive branch departments, boards and commissions, and public corporations to assure compliance with legal standards for legislation and regulations. The section advises the Office of the Governor on legislative and constitutional matters, the Office of the Lieutenant Governor on regulations, and the Office of Management and Budget on budget and legislative matters. The section also provides legal research services within the Department of Law and to state agencies.

Core Services

- Draft legislation, including budget bills, for introduction in the legislature on behalf of the Governor.
- Provide final legal review of all regulations adopted under the Alaska Administrative Procedure Act.
- Review all enacted legislation for legal issues and coordinate review for the Governor of all enacted legislation.
- Coordinate responses to legal questions and requests for information from legislators to the Department of Law and coordinate necessary testimony before legislative committees. Compile legislative reports on federal issues.
- Work closely with the Office of Management and Budget to draft the budget bills; provide advice year-round on budget-related issues and interpretation. Assist on litigation related to budget matters.
- Prepare and publish the Drafting Manual for Administrative Regulations, which all agencies must, by statute, follow. Prepare and present training to multiple agencies.
- The section supervisor serves as the executive branch representative to the National Conference of Commissioners on Uniform State Laws.
- Act as the main point of contact and coordinate responses for many Governors' office legal inquiries.
- Provide legal research services to the Department of Law and executive branch agencies.

Major Component Accomplishments in 2021

- Completed a comprehensive update and re-write of the Drafting Manual for Administrative Regulations.
- Provided training to Department of Law attorneys and state agency regulations contacts on legislative and regulation drafting.
- Coordinated and drafted legislative bills on behalf of the administration for the first year of the 32nd legislative session, including four special sessions.
- The section drafted approximately 101 bills at the request of the administration.
- The section updated its electronic document management system and all of its internal processes to provide for increased efficiency and streamlining of functions.

Key Component Challenges

The section assists executive agencies with legislation and regulations designed to increase efficient operation of state agencies and decrease costs of programs. For legislation, the section continues to draft legislation for introduction by the Governor.

The number of regulation projects continues to increase, consistently challenging the section's ability to perform a timely review of regulations. As required by statute, the section reviews adopted regulations for legality, constitutionality and clarity. The section anticipates its role in advising on regulations process matters will continue to grow.

Whenever major program and policy changes are implemented, the section strives to meet the increased need for assistance by working with client agencies to provide timely changes to statutes, regulations, or a combination of both.

Significant Changes in Results to be Delivered in FY2023

The section anticipates that legislative enactments and regulations will continue as the administration and legislature continue to seek ways to streamline operations and provide services with reduced funding. Budget issues often require legislative attention, and the section anticipates an increase in legislative needs in both drafting and monitoring activities.

Statutory and Regulatory Authority

AS 44.23.020
AS 44.23.030
AS 44.23.040
AS 44.62.050
AS 44.62.060
AS 44.62.125

Contact Information
<p>Contact: Rebecca Polizzotto, Chief Assistant Attorney General Phone: (907) 465-3600 E-mail: rebecca.polizzotto@alaska.gov</p>

Legislation/Regulations Personal Services Information				
Authorized Positions			Personal Services Costs	
	FY2022 Management Plan	FY2023 Governor		
Full-time	10	10	Annual Salaries	997,826
Part-time	0	0	Premium Pay	0
Nonpermanent	0	0	Annual Benefits	569,850
			<i>Less 0.81% Vacancy Factor</i>	(12,776)
			Lump Sum Premium Pay	0
Totals	10	10	Total Personal Services	1,554,900

Position Classification Summary					
Job Class Title	Anchorage	Fairbanks	Juneau	Others	Total
Associate Attorney 2	0	0	2	0	2
Attorney 3	1	0	0	0	1
Attorney 4	1	0	0	0	1
Attorney 5	1	0	2	0	3
Attorney 6	0	0	1	0	1
Law Office Assistant 1	0	0	1	0	1
Paralegal 2	0	0	1	0	1
Totals	3	0	7	0	10

Component Detail All Funds
Department of Law

Component: Legislation/Regulations (2209)
RDU: Civil Division (Excludes Janus) (35)

Non-Formula Component

	FY2021 Actuals	FY2022 Conference Committee	FY2022 Authorized	FY2022 Management Plan	FY2023 Governor	FY2022 Management Plan vs FY2023 Governor	
71000 Personal Services	946.4	1,305.2	1,305.2	1,592.7	1,554.9	-37.8	-2.4%
72000 Travel	1.7	19.5	19.5	19.5	19.5	0.0	0.0%
73000 Services	174.8	117.6	117.6	117.6	117.6	0.0	0.0%
74000 Commodities	10.4	21.4	21.4	21.4	21.4	0.0	0.0%
75000 Capital Outlay	3.1	0.0	0.0	0.0	0.0	0.0	0.0%
77000 Grants, Benefits	0.0	0.0	0.0	0.0	0.0	0.0	0.0%
78000 Miscellaneous	0.0	0.0	0.0	0.0	0.0	0.0	0.0%
Totals	1,136.4	1,463.7	1,463.7	1,751.2	1,713.4	-37.8	-2.2%
Fund Sources:							
1004 Gen Fund (UGF)	912.9	1,141.6	1,141.6	1,329.3	1,287.6	-41.7	-3.1%
1007 I/A Rcpts (Other)	223.5	322.1	322.1	421.9	425.8	3.9	0.9%
Unrestricted General (UGF)	912.9	1,141.6	1,141.6	1,329.3	1,287.6	-41.7	-3.1%
Designated General (DGF)	0.0	0.0	0.0	0.0	0.0	0.0	0.0%
Other Funds	223.5	322.1	322.1	421.9	425.8	3.9	0.9%
Federal Funds	0.0	0.0	0.0	0.0	0.0	0.0	0.0%
Positions:							
Permanent Full Time	8	8	8	10	10	0	0.0%
Permanent Part Time	0	0	0	0	0	0	0.0%
Non Permanent	0	0	0	0	0	0	0.0%

Change Record Detail - Multiple Scenarios with Descriptions
Department of Law

Component: Legislation/Regulations (2209)
RDU: Civil Division (Excludes Janus) (35)

Scenario/Change Record Title	Trans Type	Totals	Personal Services	Travel	Services	Commodities	Capital Outlay	Grants, Benefits	Miscellaneous	Positions		NP
										PFT	PPT	
***** Changes From FY2022 Conference Committee To FY2022 Authorized *****												
FY2022 Conference Committee												
	ConfCom	1,463.7	1,305.2	19.5	117.6	21.4	0.0	0.0	0.0	8	0	0
1004 Gen Fund		1,141.6										
1007 I/A Rcpts		322.1										
Subtotal		1,463.7	1,305.2	19.5	117.6	21.4	0.0	0.0	0.0	8	0	0
***** Changes From FY2022 Authorized To FY2022 Management Plan *****												
Transfer Attorney 4 (03-0410) from Special Litigation for Required Legal Expertise												
	Trin	146.4	146.4	0.0	0.0	0.0	0.0	0.0	0.0	1	0	0
1004 Gen Fund		117.1										
1007 I/A Rcpts		29.3										
Transfer one full-time Attorney 4 position (03-0410), range 24, located in Anchorage, from the Special Litigation component to the Legislation/Regulations component to keep pace with the required level of legal expertise needed within the office. The remaining staff in Special Litigation are sufficient to accommodate anticipated workload.												
Transfer Attorney 3 (03-0243) from Labor and State Affairs for Required Legal Expertise												
	Trin	141.1	141.1	0.0	0.0	0.0	0.0	0.0	0.0	1	0	0
1004 Gen Fund		70.6										
1007 I/A Rcpts		70.5										
Transfer one full-time Attorney 3 position (03-0243), range 22, located in Anchorage, from the Labor and State Affairs component to the Legislation/Regulations component to keep pace with the required level of legal expertise needed within the office. The remaining staff in Labor and State Affairs are sufficient to accommodate anticipated workload.												
Subtotal		1,751.2	1,592.7	19.5	117.6	21.4	0.0	0.0	0.0	10	0	0
***** Changes From FY2022 Management Plan To FY2023 Governor *****												
FY2023 Executive Health Insurance, SBS, and Risk Management Rate Changes												
	SalAdj	15.6	15.6	0.0	0.0	0.0	0.0	0.0	0.0	0	0	0
1004 Gen Fund		11.8										
1007 I/A Rcpts		3.8										
FY2023 Change Partially Exempt & Exempt Executive (EE) - Health Insurance from \$1,555 to \$1,685; SBS and Risk Management Rates: \$15.6												
FY2023 General Government Unit SBS and Risk Management Rate Changes												
	SalAdj	0.3	0.3	0.0	0.0	0.0	0.0	0.0	0.0	0	0	0
1004 Gen Fund		0.2										
1007 I/A Rcpts		0.1										

Change Record Detail - Multiple Scenarios with Descriptions
Department of Law

Component: Legislation/Regulations (2209)
RDU: Civil Division (Excludes Janus) (35)

Scenario/Change Record Title	Trans Type	Totals	Personal Services	Travel	Services	Commodities	Capital Outlay	Grants, Benefits	Miscellaneous	Positions		NP
										PFT	PPT	
FY2023 Change General Government Unit (GG, GP, GY, GZ) - SBS, and Risk Management Rates: \$0.3												
FY2023 PERS Actuarial Rate Adjustment to 24.79% Ch9 SLA2021 (SB55)												
	SalAdj	-53.7	-53.7	0.0	0.0	0.0	0.0	0.0	0.0	0	0	0
1004 Gen Fund		-39.7										
1007 I/A Rcpts		-14.0										
Includes: FY2023 Adjustment for PERS ARM Board Approved Rate of 24.79% (from 30.11%): \$-53.7												
Realign PERS Rate Adjustment by Fund Source Ch9 SLA2021 (SB55)												
	FndChg	0.0	0.0	0.0	0.0	0.0	0.0	0.0	0.0	0	0	0
1004 Gen Fund		-14.0										
1007 I/A Rcpts		14.0										
Remove one-time UGF subsidy for rate agency assigned in SB55 fiscal note (Ch 9 SLA 2021).												
Totals		1,713.4	1,554.9	19.5	117.6	21.4	0.0	0.0	0.0	10	0	0

Line Item Detail (1676)
Department of Law
Travel

Component: Legislation/Regulations (2209)

Line Number	Line Name		FY2021 Actuals	FY2022 Management Plan	FY2023 Governor
2000	Travel		1.7	19.5	19.5
Object Class	Servicing Agency	Explanation	FY2021 Actuals	FY2022 Management Plan	FY2023 Governor
2000 Travel Detail Totals			1.7	19.5	19.5
2000	In-State Employee Travel	Travel for attorneys to interview witnesses and attend court proceedings, as well as for necessary training for both attorneys and paraprofessionals. Includes travel for management purposes.	0.0	16.8	16.8
2006	Other Travel Costs	Travel cost transfers.	1.7	2.7	2.7

Line Item Detail (1676)
Department of Law
Services

Component: Legislation/Regulations (2209)

Line Number	Line Name		FY2021 Actuals	FY2022 Management Plan	FY2023 Governor
3000	Services		174.8	117.6	117.6
Object Class	Servicing Agency	Explanation	FY2021 Actuals	FY2022 Management Plan	FY2023 Governor
3000 Services Detail Totals			174.8	117.6	117.6
3000	Education Services	Conferences, training and memberships.	39.9	40.0	40.0
3002	Legal and Judicial Services	Depositions, research costs, expert witness and consultant fees.	3.5	3.5	3.5
3011	Other Services	Cost transfers and miscellaneous items within the services line (commissions, etc.).	125.1	67.8	67.8
3013	Inter-Agency Data Processing Operations Allocation	Law - Administrative Services (2164) RSA Law, Information services, data processing investments and support.	0.4	0.4	0.4
3017	Inter-Agency Information Technology Non-Telecommunications	Admin - Department-wide RSA Administration, Office of Information Technology computer services.	4.0	4.0	4.0
3018	Inter-Agency Information Technology Telecommunications	Admin - Department-wide RSA Administration, Office of Information Technology telecommunications services.	0.5	0.5	0.5
3021	Inter-Agency Mail	Admin - Department-wide RSA Administration, Central Mail.	0.3	0.3	0.3
3022	Inter-Agency Human Resources	Law - Administrative Services (2164) RSA Law, Human Resources position.	0.9	0.9	0.9
3026	Inter-Agency Insurance	RSA Administration, Risk Management.	0.1	0.1	0.1
3027	Inter-Agency Financial	Admin - Department-wide RSA Administration, Finance Chargeback (IRIS).	0.1	0.1	0.1

Line Item Detail (1676)
Department of Law
Commodities

Component: Legislation/Regulations (2209)

Line Number	Line Name		FY2021 Actuals	FY2022 Management Plan	FY2023 Governor
4000	Commodities		10.4	21.4	21.4
Object Class	Servicing Agency	Explanation	FY2021 Actuals	FY2022 Management Plan	FY2023 Governor
4000 Commodities Detail Totals			10.4	21.4	21.4
4000	Business	Reference materials and subscriptions, including statutes, software applications, non-capital desktop refresh, and miscellaneous office supplies.	1.4	1.4	1.4
4022	Commodity Transfer	Commodity cost transfers.	9.0	20.0	20.0

Line Item Detail (1676)
Department of Law
Capital Outlay

Component: Legislation/Regulations (2209)

Line Number	Line Name		FY2021 Actuals	FY2022 Management Plan	FY2023 Governor
5000	Capital Outlay		3.1	0.0	0.0
Object Class	Servicing Agency	Explanation	FY2021 Actuals	FY2022 Management Plan	FY2023 Governor
5000 Capital Outlay Detail Totals			3.1	0.0	0.0
5009	Capital Outlay Transfer	Capital cost transfers.	3.1	0.0	0.0

Revenue Detail (1681)
Department of Law

Component: Legislation/Regulations (2209)

Revenue Type (OMB Fund Code) Revenue Source	Component	Comment	FY2021 Actuals	FY2022 Management Plan	FY2023 Governor
5007 I/A Rcpts (1007 I/A Rcpts)			223.5	421.9	425.8
5301 Inter-Agency Receipts	Admin - Department-wide	RSA Administration, Department-wide - legal services for legislation and regulations review. Program code: CV03207751.	4.9	10.0	10.0
5301 Inter-Agency Receipts	Commerce - Department-wide	RSA Commerce, Department-wide - legal services for legislation and regulations review. Program code: CV03207751.	61.9	100.0	100.0
5301 Inter-Agency Receipts	Correct - Department-wide	RSA Corrections, Department-wide - legal services for legislation and regulations review. Program code: CV03207751.	0.5	5.0	5.0
5301 Inter-Agency Receipts	E&ED - Department-wide	RSA Education, Department-wide - legal services for legislation and regulations review. Program code: CV03207751.	10.5	20.0	20.0
5301 Inter-Agency Receipts	EnvCon - Department-wide	RSA Environmental Conservation, Department-wide - legal services for legislation and regulations. Program code: CV03207751.	34.2	70.0	70.0
5301 Inter-Agency Receipts	FishGm - Department-wide	RSA Fish and Game, Department-wide - legal services for legislation and regulations review. Program code: CV03207751.	37.7	70.0	70.0
5301 Inter-Agency Receipts	Health - Department-wide	RSA Health and Social Services, Department-wide - legal services for legislation and regulations review. Program code: CV03207751.	34.2	50.0	50.0
5301 Inter-Agency Receipts	Labor - Department-wide	RSA Labor, Department-wide - legal services for legislation and regulations review. Program code: CV03207751.	5.6	10.0	10.0
5301 Inter-Agency Receipts	M&VA - Department-wide	RSA Military and Veteran's Affairs, Department-wide - legal services for legislation and regulations. Program	0.2	5.0	5.0

Revenue Detail (1681)
Department of Law

Component: Legislation/Regulations (2209)

Revenue Type (OMB Fund Code) Revenue Source	Component	Comment	FY2021 Actuals	FY2022 Management Plan	FY2023 Governor
5301 Inter-Agency Receipts	NatRes - Department-wide	code: CV03207751. RSA Natural Resources, Department-wide - legal services for legislation and regulations review. Program code: CV03207751.	10.0	20.0	20.0
5301 Inter-Agency Receipts	PubSaf - Department-wide	RSA Public Safety, Department-wide - legal services for legislation and regulations review. Program code: CV03207751.	7.5	15.0	15.0
5301 Inter-Agency Receipts	Rev - Department-wide	RSA Revenue, Department-wide - legal services for legislation and regulations review. Program code: CV03207751.	8.7	15.0	15.0
5301 Inter-Agency Receipts	Trans - Department-wide	RSA Transportation, Department-wide - legal services for legislation and regulations review. Program code: CV03207751.	5.1	10.0	10.0
5301 Inter-Agency Receipts	Admin - Department-wide	RSA Administration, Alaska Oil and Gas Conservation Commission - legal services for legislation and regulations review. Program code: CV03207751.	0.6	5.0	5.0
5301 Inter-Agency Receipts	FishGm - Department-wide	RSA Fish and Game, Commercial Fisheries Entry Commission - legal services for legislation and regulations. Program code: CV03207751.	1.0	5.9	5.8
5301 Inter-Agency Receipts	Gov - Department-wide	RSA Office of the Governor, Elections - legal services for legislation and regulations. Program code: CV03207751.	0.9	11.0	15.0

Inter-Agency Services (1682)
Department of Law

Component: Legislation/Regulations (2209)

				FY2021 Actuals	FY2022 Management Plan	FY2023 Governor
Component Totals				6.2	6.2	6.2
With Department of Law				1.3	1.3	1.3
With Department of Administration				4.9	4.9	4.9
Object Class	Servicing Agency	Explanation		FY2021 Actuals	FY2022 Management Plan	FY2023 Governor
3013	Inter-Agency Data Processing Operations Allocation	Law - Administrative Services (2164)	RSA Law, Information services, data processing investments and support.	0.4	0.4	0.4
3017	Inter-Agency Information Technology Non-Telecommunications	Admin - Department-wide	RSA Administration, Office of Information Technology computer services.	4.0	4.0	4.0
3018	Inter-Agency Information Technology Telecommunications	Admin - Department-wide	RSA Administration, Office of Information Technology telecommunications services.	0.5	0.5	0.5
3021	Inter-Agency Mail	Admin - Department-wide	RSA Administration, Central Mail.	0.3	0.3	0.3
3022	Inter-Agency Human Resources	Law - Administrative Services (2164)	RSA Law, Human Resources position.	0.9	0.9	0.9
3027	Inter-Agency Financial	Admin - Department-wide	RSA Administration, Finance Chargeback (IRIS).	0.1	0.1	0.1

Personal Services Expenditure Detail
Department of Law

Scenario: FY2023 Governor (18673)
Component: Legislation/Regulations (2209)
RDU: Civil Division (Excludes Janus) (35)

PCN	Job Class Title	Time Status	Retire Code	Barg Unit	Location	Salary Sched	Range / Step	Comp Months	Split / Count	Annual Salaries	COLA	Premium Pay	Annual Benefits	Total Costs	UGF Amount
03-0056	Attorney 6	FT	A	XE	Juneau	N05	26O	12.0		150,774	0	0	76,121	226,895	226,895
03-0139	Attorney 5	FT	A	XE	Juneau	99	25Q / R	12.0		160,598	0	0	79,176	239,774	71,932
03-0146	Associate Attorney 2	FT	A	XE	Juneau	N05	19C / D	12.0		74,383	0	0	47,930	122,313	122,313
03-0243	Attorney 3	FT	A	XE	Anchorage	N00	22D / E	12.0		88,943	0	0	53,351	142,294	71,147
03-0290	Associate Attorney 2	FT	A	XE	Juneau	N05	19M	12.0		90,909	0	0	54,083	144,992	144,992
03-0296	Law Office Assistant 1	FT	A	GP	Juneau	205	11C / D	12.0		42,115	0	0	34,461	76,576	30,630
03-0320	Attorney 4	FT	A	XE	Anchorage	N00	24C / D	12.0		97,861	0	0	56,671	154,532	115,899
03-0381	Attorney 5	FT	A	XE	Juneau	N05	25F	12.0		120,140	0	0	64,965	185,105	138,829
03-0410	Attorney 5	FT	A	XE	Anchorage	N00	25F	12.0		114,426	0	0	62,838	177,264	141,811
03-0429	Paralegal 2	FT	A	GP	Juneau	205	16B / C	12.0		57,677	0	0	40,254	97,931	97,931
													Total Salary Costs:	997,826	
													Total COLA:	0	
													Total Premium Pay:	0	
													Total Benefits:	569,850	
													Total Pre-Vacancy:	1,567,676	
													Minus Vacancy Adjustment of 0.81%:	(12,776)	
													Total Post-Vacancy:	1,554,900	
													Plus Lump Sum Premium Pay:	0	
													Personal Services Line 100:	1,554,900	

PCN Funding Sources:	Pre-Vacancy	Post-Vacancy	Percent
1004 General Fund Receipts	1,162,380	1,152,907	74.15%
1007 Interagency Receipts	405,296	401,993	25.85%
Total PCN Funding:	1,567,676	1,554,900	100.00%

Note: If a position is split, an asterisk (*) will appear in the Split/Count column. If the split position is also counted in the component, two asterisks (**) will appear in this column. [No valid job title] appearing in the Job Class Title indicates that the PCN has an invalid class code or invalid range for the class code effective date of this scenario.

CIVIL DIVISION

Legislation/Regulations

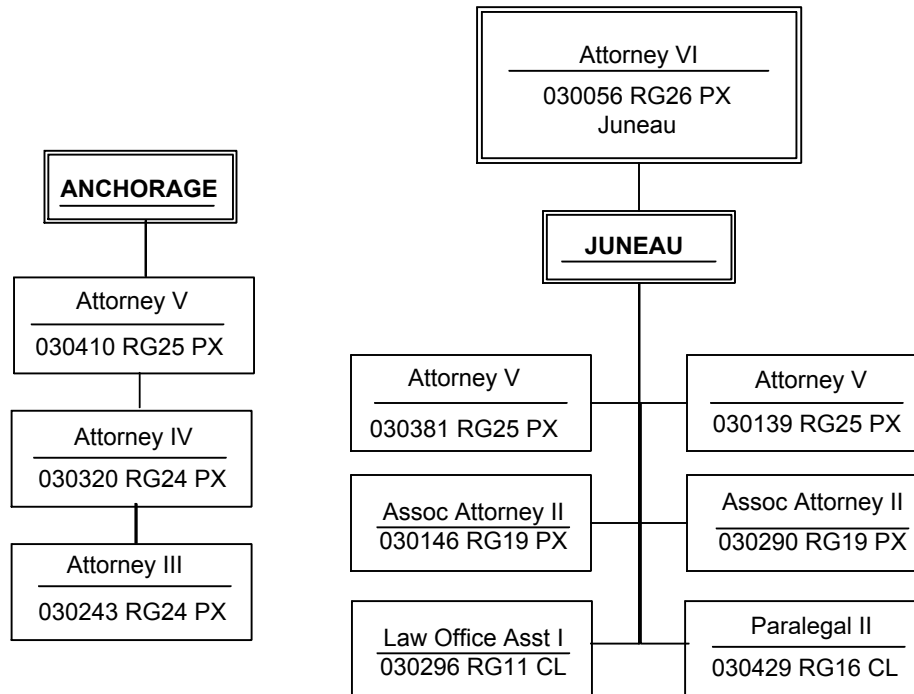

State of Alaska FY2023 Governor's Operating Budget

Department of Law Natural Resources Component Budget Summary

Component: Natural Resources**Contribution to Department's Mission**

The Natural Resources Section provides legal advice and representation to state departments and to boards and commissions that manage and regulate all of Alaska's natural resources, including its land, water, oil, gas, fish, game, timber, and minerals. The section defends actions taken by the state's natural resource agencies, and litigates disputes involving the state's proprietary interests in its natural resources. The section also represents the state on issues raised by conflicts between state and federal jurisdiction and in the investigation, defense, and prosecution of claims based on the state's oil and gas royalty and taxation programs.

Core Services

- The Natural Resources section advises the Department of Natural Resources (DNR), the Department of Fish and Game (DFG) and the Department of Revenue. The section provides advice to ensure that Alaska land (including mental health trust land), water, oil, gas, fish, game, timber, minerals, and other natural resources are managed and allocated by state agencies in accordance with state law.
- The section also provides legal advice and assistance to the state on all natural resource-related issues and disputes, and advises state agencies on oil and gas royalties and net profit shares, and corporate, property, and production tax issues.
- Section attorneys handle complex cases arising out of state/federal jurisdictional conflicts that profoundly affect management of Alaska's natural resources. Issues include title navigability, Revised Statute (RS) 2477 rights-of-way, access across and within federal lands, Alaska National Interest Lands Conservation Act questions, Alaska Native Claims Settlement Act conveyances and 17(b) easements, fish and game management, subsistence, and Endangered Species Act issues.
- The section provides legal services related to development of a gas pipeline, development in the National Petroleum Reserve of Alaska, the Arctic National Wildlife Refuge, and on Alaska's outer continental shelf.
- Section attorneys work on large and complex oil and gas cases, issues related to timber sales, appropriation of water, lease sales, trespass issues, drafting and interpretation of natural resource statutes and regulations, pipeline and access rights-of-way, and oil and gas conservation and development.

Major Component Accomplishments in 2021

- Provided frequent advice to the Board of Fisheries and Board of Game at all board meetings, advising on regulatory proposals, assisting in drafting regulations, defending against regulatory challenges, and providing other advice as requested. Also advised and assisted the statewide fish and game prosecutor and the district attorney's office in prosecutions of fish and game violations.
- Advised and represented DFG in litigation on community subsistence hunting regulations for moose and caribou in the Copper River Basin and on issues related to the development, amendment, interpretation, and enforcement of special area management plans, regulations, and statutes, as well as on the issuance, appeal, and enforcement of special area permits and fish habitat permits.
- Litigated against federal agencies to challenge regulations adopted by the National Park Service and the U.S. Fish and Wildlife Service that prohibit the state from exercising its full authority to manage fish and game within federal parks and refuges.
- Litigated against federal agencies to challenge delegation of subsistence game management decisions to local federal land managers.
- Intervened in federal litigation that upheld Congress's use of the Congressional Review Act to revoke certain federal regulations, including rules affecting the state's management of fish and game in federal refuges.
- Intervened in federal litigation to defend the federal authorizations for the ANWR leasing

- Defended the state's regulatory authority in cases challenging DFG and Board of Game regulations on fisheries management in Sitka Sound and Upper Cook Inlet.
- Defended and prosecuted the state's interests in 15 quiet title actions involving access, trespass, and accretion or reliction issues.
- Provided advice to DNR's Division of Forestry on forest management planning and timber harvests.
- Provided advice and assistance to DNR's Division of Forestry on fire suppression actions and cost recoveries.
- Advised the Commercial Fisheries Entry Commission on issues relating to regulation and management of limited entry of commercial fisheries, including legislation, regulations, child support lien issues, and defense of decisions.
- Advised DNR on land and mineral leasing issues, including renewals, terminations, assignments, and amendments.
- Advised the Alaska Mental Health Trust Land Office extensively on real estate matters, including real estate acquisition, sales and leasing, and mineral leasing issues.
- Advised DNR on statehood entitlement issues, municipal entitlement issues, survey issues regarding state lands, and federal/state boundary and access issues.
- Advised the DNR Commissioner's office regarding administrative and state court appeals of department decisions.
- Defended the state in litigation challenging application of the Limited Entry fishing program to Metlakatlan fishing outside the boundaries of the Annette Islands Reserve.
- Continued litigation against the United States to quiet title to the beds of two navigable rivers in Alaska (North Fork and Middle Fork of the Fortymile) and advised DNR on other title issues involving beds of navigable waters.
- Defended the state in quiet title action regarding the bed of Lemon Creek in Juneau.
- Continued prosecuting and defending claims to quiet title to RS 2477 rights-of-way across Alaska, including in the historic Fortymile mining district and the Brenwick-Craig right-of-way (Klutina Lake Road).
- Defended on appeal the state's recovery of attorney fees in litigation recognizing the historic Iditarod Trail RS 2477.
- Advised DNR on public access issues, including public trust doctrine and RS 2477 section-line easement access to Campbell Lake in Anchorage and other section line and RST routes.
- Advised DNR on revised regulations about navigable and public waters to facilitate disposal of land through municipal land entitlement selections.
- Advised DNR and DFG about management of navigable rivers within federal conservation system units and federal withdrawals to implement the 2019 *Sturgeon v. Frost* decision and further the Unlocking Alaska Initiative.
- Prosecuted and defended multiple actions involving the Tongass National Forest, including the Roadless Rule and the Tongass Land Management Plan. Continued to advise DNR on revision of various federal land management plans, including the Eastern Interior, Central Yukon, and Bering Straits-Western Interior Regional Management plans.
- Supported the federal government, King Cove Corporation, and others in litigation to defend a land exchange.

- Advised the state on federal actions taken under the Endangered Species Act, including actions taken with respect to ringed seals, bearded seals, Puget Sound orcas, and the definition of critical habitat.
- Intervened in litigation challenging National Marine Fishing Service authorization for underwater seismic testing in Cook Inlet.
- Advised DNR on decisions about oil and gas leases and development, including leasing, unitization, termination, assignments, and amendments.
- Advised and represented DNR in audits of oil and gas royalties and net profit shares for North Slope and Cook Inlet fields.
- Intervened in federal litigation to defend the federal executive order that re-opened areas of the Chukchi and Beaufort Seas to oil and gas leasing.
- Represented the Department of Revenue in negotiating settlement of several corporate income tax, production tax, tax credit, and property tax disputes.
- Defended the state in litigation challenging a tax statute as unconstitutional.
- Defended the state in litigation challenging the legality of a Department of Revenue advisory bulletin on a production tax issue.

Key Component Challenges

- Protecting the state's claim to its statehood entitlement lands and its title to the beds underlying navigable waters against the federal government and others; asserting and protecting access across Alaska granted under RS 2477, a federal law that granted rights-of-way on public lands; and advising on the state's rights and obligations under the public trust doctrine.
- Assisting DNR in permitting and land use authorizations to further responsible natural resource development and resisting an increasing number of challenges from groups hoping to prevent development or limit use of state land and resources.
- Protecting Alaska's sovereign authority to manage fish and game on all lands in Alaska against federal encroachment.
- Defending Alaska's sovereign and proprietary rights by intervening in federal litigation challenging major resource and infrastructure development projects and Endangered Species Act issues.
- Representing DNR in royalty disputes and working with DNR in royalty negotiations to ensure that the state receives its fair share of royalties and net profit share from production of Alaska oil and gas resources. This work includes handling related development and production sharing disputes.
- Defending the state's interests and goals from increasing restrictions under federal statutes and regulations. The expanding nature of this work requires strategically selecting the cases for litigation that are most likely to achieve the state's goals.
- Advising and representing the Alaska Oil and Gas Conservation Commission about all aspects of the commission's oversight of oil and gas drilling, development, production, metering, and reservoir depletion.
- Attorney turnover and a difficult recruiting environment coupled with a high volume of work has negatively impacted the section's ability to deliver timely client services regarding non-oil and gas programs.

Significant Changes in Results to be Delivered in FY2023

No significant changes are anticipated in the next fiscal year.

Statutory and Regulatory Authority

AS 44.23.020

Contact Information
<p>Contact: Anne Nelson, Chief Assistant Attorney General Phone: (907) 269-5100 E-mail: anne.nelson@alaska.gov</p>

Natural Resources Personal Services Information				
Authorized Positions			Personal Services Costs	
	<u>FY2022</u> <u>Management</u> <u>Plan</u>	<u>FY2023</u> <u>Governor</u>		
Full-time	26	26	Annual Salaries	2,600,137
Part-time	0	0	COLA	752
Nonpermanent	0	0	Premium Pay	0
			Annual Benefits	1,475,980
			<i>Less 4.59% Vacancy Factor</i>	(187,269)
			Lump Sum Premium Pay	0
Totals	26	26	Total Personal Services	3,889,600

Position Classification Summary					
Job Class Title	Anchorage	Fairbanks	Juneau	Others	Total
Associate Attorney 1	1	0	0	0	1
Attorney 3	2	0	0	0	2
Attorney 4	7	0	1	0	8
Attorney 5	6	0	1	0	7
Attorney 6	2	0	0	0	2
Law Office Assistant 1	2	0	2	0	4
Law Office Assistant 2	1	0	0	0	1
Paralegal 2	1	0	0	0	1
Totals	22	0	4	0	26

Component Detail All Funds
Department of Law

Component: Natural Resources (2212)
RDU: Civil Division (Excludes Janus) (35)

Non-Formula Component

	FY2021 Actuals	FY2022 Conference Committee	FY2022 Authorized	FY2022 Management Plan	FY2023 Governor	FY2022 Management Plan vs FY2023 Governor	
71000 Personal Services	3,933.5	3,811.0	3,811.0	3,981.1	3,889.6	-91.5	-2.3%
72000 Travel	9.0	63.3	63.3	63.3	63.3	0.0	0.0%
73000 Services	2,254.5	4,094.4	4,094.4	4,094.4	4,094.4	0.0	0.0%
74000 Commodities	43.8	44.9	44.9	44.9	44.9	0.0	0.0%
75000 Capital Outlay	15.0	0.0	0.0	0.0	0.0	0.0	0.0%
77000 Grants, Benefits	0.0	0.0	0.0	0.0	0.0	0.0	0.0%
78000 Miscellaneous	0.0	0.0	0.0	0.0	0.0	0.0	0.0%
Totals	6,255.8	8,013.6	8,013.6	8,183.7	8,092.2	-91.5	-1.1%
Fund Sources:							
1004 Gen Fund (UGF)	2,270.6	4,099.9	4,099.9	4,236.0	4,125.4	-110.6	-2.6%
1007 I/A Rcpts (Other)	1,237.4	1,226.0	1,226.0	1,260.0	1,266.1	6.1	0.5%
1061 CIP Rcpts (Other)	45.8	0.0	0.0	0.0	0.0	0.0	0.0%
1105 PFund Rcpt (Other)	2,619.1	2,687.7	2,687.7	2,687.7	2,700.7	13.0	0.5%
1236 AK LNG I/A (Other)	82.9	0.0	0.0	0.0	0.0	0.0	0.0%
Unrestricted General (UGF)	2,270.6	4,099.9	4,099.9	4,236.0	4,125.4	-110.6	-2.6%
Designated General (DGF)	0.0	0.0	0.0	0.0	0.0	0.0	0.0%
Other Funds	3,985.2	3,913.7	3,913.7	3,947.7	3,966.8	19.1	0.5%
Federal Funds	0.0	0.0	0.0	0.0	0.0	0.0	0.0%
Positions:							
Permanent Full Time	24	24	24	26	26	0	0.0%
Permanent Part Time	0	0	0	0	0	0	0.0%
Non Permanent	0	0	0	0	0	0	0.0%

Change Record Detail - Multiple Scenarios with Descriptions
Department of Law

Component: Natural Resources (2212)
RDU: Civil Division (Excludes Janus) (35)

Scenario/Change Record Title	Trans Type	Totals	Personal Services	Travel	Services	Commodities	Capital Outlay	Grants, Benefits	Miscellaneous	Positions		NP
										PFT	PPT	
***** Changes From FY2022 Conference Committee To FY2022 Authorized *****												
FY2022 Conference Committee												
	ConfCom	8,013.6	3,811.0	63.3	4,094.4	44.9	0.0	0.0	0.0	24	0	0
1004 Gen Fund		4,099.9										
1007 I/A Rcpts		1,226.0										
1105 PFund Rcpt		2,687.7										
Subtotal		8,013.6	3,811.0	63.3	4,094.4	44.9	0.0	0.0	0.0	24	0	0
***** Changes From FY2022 Authorized To FY2022 Management Plan *****												
Transfer Attorney 4 (03-0026) from Special Litigation for Required Legal Expertise												
	Trin	170.1	170.1	0.0	0.0	0.0	0.0	0.0	0.0	1	0	0
1004 Gen Fund		136.1										
1007 I/A Rcpts		34.0										
Transfer one full-time Attorney 4 position (03-0026), range 24, located in Anchorage, from the Special Litigation component to the Natural Resources component to keep pace with the required level of legal expertise needed within the office. The remaining staff in Special Litigation are sufficient to accommodate anticipated workload.												
Transfer Law Office Assistant 1 (03-0083) from Labor and State Affairs to Address Workload Demands												
	Trin	0.0	0.0	0.0	0.0	0.0	0.0	0.0	0.0	1	0	0
Transfer a full-time Law Office Assistant 1 (03-0083), range 11, located in Juneau, from the Labor and State Affairs component to the Natural Resources component to accommodate workload demands. The remaining staff in Labor and State Affairs are sufficient to cover the anticipated workload.												
Subtotal		8,183.7	3,981.1	63.3	4,094.4	44.9	0.0	0.0	0.0	26	0	0
***** Changes From FY2022 Management Plan To FY2023 Governor *****												
FY2023 Salary and Benefit Adjustments												
	SalAdj	0.8	0.8	0.0	0.0	0.0	0.0	0.0	0.0	0	0	0
1007 I/A Rcpts		0.4										
1105 PFund Rcpt		0.4										
FY2023 SU BU - Supervisory Employees (SS) 1% COLA: \$0.8												
FY2023 Executive Health Insurance, SBS, and Risk Management Rate Changes												
	SalAdj	36.7	36.7	0.0	0.0	0.0	0.0	0.0	0.0	0	0	0
1004 Gen Fund		20.6										
1007 I/A Rcpts		4.4										
1105 PFund Rcpt		11.7										

Change Record Detail - Multiple Scenarios with Descriptions
Department of Law

Component: Natural Resources (2212)
RDU: Civil Division (Excludes Janus) (35)

Scenario/Change Record Title	Trans Type	Totals	Personal Services	Travel	Services	Commodities	Capital Outlay	Grants, Benefits	Miscellaneous	Positions		NP
										PFT	PPT	
FY2023 Change Partially Exempt & Exempt Executive (EE) - Health Insurance from \$1,555 to \$1,685; SBS and Risk Management Rates: \$36.7												
FY2023 Supervisory Employees Health Insurance, SBS, and Risk Management Rate Changes												
	SalAdj	1.6	1.6	0.0	0.0	0.0	0.0	0.0	0.0	0	0	0
1007 I/A Rcpts		0.8										
1105 PFund Rcpt		0.8										
FY2023 Change Supervisory Employees (SS) - Health Insurance from \$1,555 to \$1,685; SBS and Risk Management Rates: \$1.6												
FY2023 General Government Unit SBS and Risk Management Rate Changes												
	SalAdj	0.7	0.7	0.0	0.0	0.0	0.0	0.0	0.0	0	0	0
1004 Gen Fund		0.1										
1007 I/A Rcpts		0.5										
1105 PFund Rcpt		0.1										
FY2023 Change General Government Unit (GG, GP, GY, GZ) - SBS, and Risk Management Rates: \$0.7												
FY2023 PERS Actuarial Rate Adjustment to 24.79% Ch9 SLA2021 (SB55)												
	SalAdj	-131.3	-131.3	0.0	0.0	0.0	0.0	0.0	0.0	0	0	0
1004 Gen Fund		-65.3										
1007 I/A Rcpts		-23.7										
1105 PFund Rcpt		-42.3										
Includes: FY2023 Adjustment for PERS ARM Board Approved Rate of 24.79% (from 30.11%): \$-131.3												
Realign PERS Rate Adjustment by Fund Source Ch9 SLA2021 (SB55)												
	FndChg	0.0	0.0	0.0	0.0	0.0	0.0	0.0	0.0	0	0	0
1004 Gen Fund		-66.0										
1007 I/A Rcpts		23.7										
1105 PFund Rcpt		42.3										
Remove one-time UGF subsidy for rate agency assigned in SB55 fiscal note (Ch 9 SLA 2021).												
Totals		8,092.2	3,889.6	63.3	4,094.4	44.9	0.0	0.0	0.0	26	0	0

Line Item Detail (1676)
Department of Law
Travel

Component: Natural Resources (2212)

Line Number	Line Name		FY2021 Actuals	FY2022 Management Plan	FY2023 Governor
2000	Travel		9.0	63.3	63.3
Object Class	Servicing Agency	Explanation	FY2021 Actuals	FY2022 Management Plan	FY2023 Governor
2000 Travel Detail Totals			9.0	63.3	63.3
2000	In-State Employee Travel	Travel for attorneys to interview witnesses and attend court proceedings, as well as for necessary training for both attorneys and paraprofessionals. Includes travel for management purposes.	0.7	18.8	18.8
2001	In-State Non-Employee Travel	Travel costs for witnesses to testify in court.	0.0	10.7	10.7
2002	Out of State Employee Travel	Travel costs and expenses for out-of-state travel for conferences, training, etc.	0.0	7.7	7.7
2006	Other Travel Costs	Travel cost transfers.	8.3	26.1	26.1

Line Item Detail (1676)
Department of Law
Services

Component: Natural Resources (2212)

Line Number	Line Name		FY2021 Actuals	FY2022 Management Plan	FY2023 Governor
3000	Services		2,254.5	4,094.4	4,094.4
Object Class	Servicing Agency	Explanation	FY2021 Actuals	FY2022 Management Plan	FY2023 Governor
3000 Services Detail Totals			2,254.5	4,094.4	4,094.4
3000	Education Services	Conferences, training and memberships.	15.3	15.3	15.3
3002	Legal and Judicial Services	Depositions, research costs, expert witness and consultant fees.	570.2	968.9	968.9
3003	Information Technology	Training, consulting and software licensing and maintenance. Annual maintenance fee for mission-critical information management systems.	0.0	1.5	1.5
3006	Delivery Services	Freight, courier, postage, and transportation of trial exhibit materials.	0.1	1.5	1.5
3009	Structure/Infrastructure/Land	Rentals/leases - records and evidence storage.	40.1	50.0	50.0
3011	Other Services	Cost transfers and miscellaneous items within the services line (commissions, etc.).	1,627.4	3,055.6	3,055.6
3017	Inter-Agency Information Technology Non-Telecommunications	Admin - Department-wide RSA Administration, Office of Information Technology computer services.	0.6	0.8	0.8
3029	Inter-Agency Education/Training	Classes and training offered by another state department.	0.8	0.8	0.8

Line Item Detail (1676)
Department of Law
Commodities

Component: Natural Resources (2212)

Line Number	Line Name		FY2021 Actuals	FY2022 Management Plan	FY2023 Governor
4000	Commodities		43.8	44.9	44.9
Object Class	Servicing Agency	Explanation	FY2021 Actuals	FY2022 Management Plan	FY2023 Governor
4000 Commodities Detail Totals			43.8	44.9	44.9
4000	Business	Reference materials and subscriptions, including statutes, software applications, non-capital desktop refresh, and miscellaneous office supplies.	0.6	2.8	2.8
4022	Commodity Transfer	Commodity cost transfers.	43.2	42.1	42.1

Line Item Detail (1676)
Department of Law
Capital Outlay

Component: Natural Resources (2212)

Line Number	Line Name		FY2021 Actuals	FY2022 Management Plan	FY2023 Governor
5000	Capital Outlay		15.0	0.0	0.0
Object Class	Servicing Agency	Explanation	FY2021 Actuals	FY2022 Management Plan	FY2023 Governor
5000 Capital Outlay Detail Totals			15.0	0.0	0.0
5009	Capital Outlay Transfer	Capital cost transfers.	15.0	0.0	0.0

Revenue Detail (1681)
Department of Law

Component: Natural Resources (2212)

Revenue Type (OMB Fund Code) Revenue Source	Component	Comment	FY2021 Actuals	FY2022 Management Plan	FY2023 Governor
5007 I/A Rcpts (1007 I/A Rcpts)			1,636.2	1,260.0	1,266.1
5301 Inter-Agency Receipts	Commerce - Department-wide	RSA Commerce, Alaska Oil and Gas Conservation Commission - legal services. Program code: CVNAR08001.	255.6	60.0	61.1
5301 Inter-Agency Receipts	FishGm - Department-wide	RSA Fish and Game, Commercial Fisheries - legal services. Program code: CV03208528.	79.0	80.0	80.0
5301 Inter-Agency Receipts	Gov - Department-wide	RSA Governor - Pebble Mine Appeal outside counsel legal services. Program code: CVNAR01001.	50.0	50.0	50.0
5301 Inter-Agency Receipts	NatRes - Department-wide	RSA Natural Resources, Mental Health Trust Authority - legal services provided to the Mental Health Trust Land Office for issues pertaining to the administration and management of Trust lands. Program code: CV03208651.	26.3	30.0	30.0
5301 Inter-Agency Receipts	NatRes - Department-wide	RSA Natural Resources, Forestry - legal services related to fire suppression actions. Program code: CV03209681.	43.2	45.0	50.0
5301 Inter-Agency Receipts	FishGm - Department-wide	RSA Fish and Game, Wildlife Conservation - legal services for Alaskan game management. Program code: CV03208630.	168.8	125.0	125.0
5301 Inter-Agency Receipts	NatRes - Department-wide	RSA Natural Resources - legal services for the Donlin Gold project. Program code: CV03204648.	3.4	5.0	5.0
5301 Inter-Agency Receipts	FishGm - Department-wide	RSA Fish and Game - Pacific salmon outside counsel legal services. Program code: CV03208631.	2.2	5.0	5.0
5301 Inter-Agency Receipts	NatRes - Department-wide	RSA Natural Resources - Surface Mining Control and Reclamation Act	4.8	5.0	5.0

Revenue Detail (1681)
Department of Law

Component: Natural Resources (2212)

Revenue Type (OMB Fund Code) Revenue Source	Component	Comment	FY2021 Actuals	FY2022 Management Plan	FY2023 Governor
5301 Inter-Agency Receipts	Rev - Department-wide	legal services. Program code: CV03204662. RSA Revenue, Mental Health Trust Authority - legal services. Program code: CV03208671.	24.8	25.0	25.0
5301 Inter-Agency Receipts	NatRes - Department-wide	RSA Natural Resources, Forestry - legal services. Program code: CV03208680.	24.9	25.0	25.0
5301 Inter-Agency Receipts	NatRes - Department-wide	RSA Natural Resources - legal services for the Ambler Road access project litigation. Program code CVNAR10007.	59.1	75.0	75.0
5301 Inter-Agency Receipts	NatRes - Department-wide	RSA Natural Resources - legal services for RS 2477 litigation. Program code: CV03208639.	143.8	150.0	150.0
5301 Inter-Agency Receipts	NatRes - Department-wide	RSA Natural Resources - legal services for defense of the mining, land and water permitting processes. Program code: CV03208549.	255.0	255.0	255.0
5301 Inter-Agency Receipts	NatRes - Department-wide	RSA Natural Resources, Commissioner's Office - outside counsel legal services for appeals. Program code: CVNAR10002.	51.7	55.0	55.0
5301 Inter-Agency Receipts	NatRes - Department-wide	RSA Natural Resources - Fort Knox gold mining project. Program code: CV03204608.	0.6	5.0	5.0
5301 Inter-Agency Receipts	NatRes - Department-wide	RSA Natural Resources - legal services for the Red Dog Mine project. Program code: CV03204615.	2.5	5.0	5.0
5301 Inter-Agency Receipts	NatRes - Department-wide	RSA Natural Resources - legal services for the Ambler Road project. Program code: CV03204651.	3.2	5.0	5.0
5301 Inter-Agency Receipts	NatRes - Department-wide	RSA Natural Resources, Project Management and Permitting - legal	19.6	20.0	20.0

Revenue Detail (1681)
Department of Law

Component: Natural Resources (2212)

Revenue Type (OMB Fund Code) Revenue Source	Component	Comment	FY2021 Actuals	FY2022 Management Plan	FY2023 Governor
5301 Inter-Agency Receipts	NatRes - Department-wide	services for the A2A Railway Project. Program code: CVNAR10008. RSA Natural Resources - legal services related to Kensington Mine. Program code: CV03204611.	0.3	5.0	5.0
5301 Inter-Agency Receipts	NatRes - Department-wide	RSA Natural Resources, Mining, Land & Water - litigation support to defend permitting process. Program code: CV03208549.	255.0	155.0	155.0
5301 Inter-Agency Receipts	NatRes - Department-wide	RSA Natural Resources - legal services for the Anarraaq Aktigirug Exploration Project. Program code: CVNAR10005.	0.2	5.0	5.0
5301 Inter-Agency Receipts	NatRes - Department-wide	RSA Natural Resources, Mining, Land & Water - legal services for RS 2477 program support. Program code: CV03208639.	143.8	50.0	50.0
5301 Inter-Agency Receipts	NatRes - Department-wide	RSA Natural Resources, State Pipeline Coordinator's Office - legal services. Program code: CV03209610.	18.4	20.0	20.0
5061 CIP Rcpts (1061 CIP Rcpts)			45.8	0.0	0.0
5351 Capital Improvement Project Inter-Agency	Gov - Department-wide	RSA Governor - Endangered Species Act-related outside counsel legal services. Program code: CVNAR10003.	45.8	0.0	0.0
5105 PFund Rcpt (1105 PFund Rcpt)			2,619.1	2,687.7	2,700.7
5414 Alaska Permanent Fund Corporation Receipts		APFC receipts	2,619.1	2,687.7	2,700.7
5236 AK LNG I/A (1236 AK LNG I/A)			82.9	0.0	0.0
5427 Alaska Liquefied Natural Gas Project Fund Inter-Agency		RSA Commerce, Alaska Gasline Development Corporation - AKLNG legal services. Program code:	31.0	0.0	0.0

Revenue Detail (1681)
Department of Law

Component: Natural Resources (2212)

Revenue Type (OMB Fund Code) Revenue Source	Component	Comment	FY2021 Actuals	FY2022 Management Plan	FY2023 Governor
5427 Alaska Liquefied Natural Gas Project Fund Inter-Agency	Commerce - Department-wide	CV03208700. RSA Commerce, Alaska Gasline Development Corporation - pipeline development outside counsel legal services. Program code: CV03208708.	1.4	0.0	0.0
5427 Alaska Liquefied Natural Gas Project Fund Inter-Agency	Commerce - Department-wide	RSA Commerce, Alaska Gasline Development Corporation - pipeline development outside counsel legal services. Program code: CV03208706.	50.5	0.0	0.0

Inter-Agency Services (1682)
Department of Law

Component: Natural Resources (2212)

				FY2021 Actuals	FY2022 Management Plan	FY2023 Governor
Component Totals				0.6	0.8	0.8
With Department of Administration				0.6	0.8	0.8
Object Class	Servicing Agency	Explanation		FY2021 Actuals	FY2022 Management Plan	FY2023 Governor
3017	Inter-Agency Information Technology Non-Telecommunications	Admin - Department-wide	RSA Administration, Office of Information Technology computer services.	0.6	0.8	0.8

Personal Services Expenditure Detail
Department of Law

Scenario: FY2023 Governor (18673)
Component: Natural Resources (2212)
RDU: Civil Division (Excludes Janus) (35)

PCN	Job Class Title	Time Status	Retire Code	Barg Unit	Location	Salary Sched	Range / Step	Comp Months	Split / Count	Annual Salaries	COLA	Premium Pay	Annual Benefits	Total Costs	UGF Amount
03-0015	Attorney 4	FT	A	XE	Juneau	N05	24F	12.0		111,774	0	0	61,851	173,625	138,900
03-0024	Attorney 6	FT	A	XE	Anchorage	N00	26S / T	12.0		163,638	0	0	80,121	243,759	0
03-0026	Attorney 4	FT	A	XE	Anchorage	N00	24F	12.0		106,451	0	0	59,869	166,320	133,056
03-0037	Attorney 6	FT	A	XE	Anchorage	N00	26M / N	12.0		135,052	0	0	70,517	205,569	205,569
03-0080	Attorney 5	FT	A	XE	Anchorage	N00	25M	12.0		130,026	0	0	68,646	198,672	198,672
03-0083	Law Office Assistant 1	FT	A	GP	Juneau	205	11E / F	12.0		46,003	0	0	35,908	81,911	12,287
03-0092	Attorney 5	FT	A	XE	Juneau	N05	25J	12.0		124,040	0	0	66,417	190,457	0
03-0147	Associate Attorney 1	FT	A	XE	Anchorage	N00	17C / D	12.0		61,909	0	0	43,286	105,195	68,377
03-0158	Attorney 5	FT	A	XE	Anchorage	N00	25F / J	12.0		115,445	0	0	63,217	178,662	0
03-0187	Law Office Assistant 2	FT	A	SS	Anchorage	600	13F / J	12.0		54,789	752	0	40,779	96,320	0
03-0215	Attorney 3	FT	A	XE	Anchorage	N00	22F	12.0		92,957	0	0	54,845	147,802	103,461
03-0216	Attorney 4	FT	A	XE	Anchorage	N00	24C / D	12.0		98,161	0	0	56,783	154,944	77,472
03-0263	Attorney 4	FT	A	XE	Anchorage	N00	24F	12.0		106,451	0	0	59,869	166,320	83,160
03-0268	Law Office Assistant 1	FT	N	GP	Anchorage	200	11C / D	12.0		40,524	0	0	23,823	64,347	64,347
03-0306	Attorney 5	FT	A	XE	Anchorage	N00	25J / K	12.0		119,187	0	0	64,611	183,798	156,228
03-0308	Attorney 5	FT	A	XE	Anchorage	99	25P / Q	12.0		145,927	0	0	74,566	220,493	44,099
03-0322	Law Office Assistant 1	FT	A	GP	Juneau	205	11C / D	12.0		42,501	0	0	34,604	77,105	0
03-0336	Attorney 4	FT	A	XE	Anchorage	99	24N	12.0		132,421	0	0	69,538	201,959	201,959
03-0337	Attorney 3	FT	A	XE	Anchorage	N00	22F	12.0		92,957	0	0	54,845	147,802	73,901
03-0367	Attorney 4	FT	A	XE	Anchorage	N00	24B / C	12.0		94,765	0	0	55,518	150,283	75,142
03-0377	Attorney 4	FT	A	XE	Anchorage	N00	24F	12.0		106,451	0	0	59,869	166,320	83,160
03-0385	Attorney 4	FT	A	XE	Anchorage	N00	24D / E	12.0		100,355	0	0	57,599	157,954	157,954
03-0395	Attorney 5	FT	A	XE	Anchorage	99	25O	12.0		140,657	0	0	72,604	213,261	0
03-0409	Attorney 5	FT	A	XE	Anchorage	N00	25J / K	12.0		119,187	0	0	64,611	183,798	165,418
03-1039	Law Office Assistant 1	FT	A	GP	Anchorage	200	11D / E	12.0		42,147	0	0	34,473	76,620	0
03-1121	Paralegal 2	FT	A	GP	Anchorage	200	16N	12.0		76,362	0	0	47,211	123,573	0
													Total Salary Costs:	2,600,137	
													Total COLA:	752	
													Total Premium Pay:	0	
													Total Benefits:	1,475,980	
													Total Pre-Vacancy:	4,076,869	
													Minus Vacancy Adjustment of 4.59%:	(187,269)	
													Total Post-Vacancy:	3,889,600	
													Plus Lump Sum Premium Pay:	0	
													Personal Services Line 100:	3,889,600	
		Total Positions	New	Deleted											
Full Time Positions:		26	0	0											
Part Time Positions:		0	0	0											
Non Permanent Positions:		0	0	0											
Positions in Component:		26	0	0											
Total Component Months:		312.0													

Note: If a position is split, an asterisk (*) will appear in the Split/Count column. If the split position is also counted in the component, two asterisks (**) will appear in this column. [No valid job title] appearing in the Job Class Title indicates that the PCN has an invalid class code or invalid range for the class code effective date of this scenario.

Personal Services Expenditure Detail
Department of Law

Scenario: FY2023 Governor (18673)
Component: Natural Resources (2212)
RDU: Civil Division (Excludes Janus) (35)

PCN Funding Sources:	Pre-Vacancy	Post-Vacancy	Percent
1004 General Fund Receipts	2,043,161	1,949,310	50.12%
1007 Interagency Receipts	756,507	721,757	18.56%
1105 Alaska Permanent Fund Corporation Receipts	1,277,201	1,218,533	31.33%
Total PCN Funding:	4,076,869	3,889,600	100.00%

Note: If a position is split, an asterisk (*) will appear in the Split/Count column. If the split position is also counted in the component, two asterisks (**) will appear in this column.
[No valid job title] appearing in the Job Class Title indicates that the PCN has an invalid class code or invalid range for the class code effective date of this scenario.

CIVIL DIVISION

Natural Resources

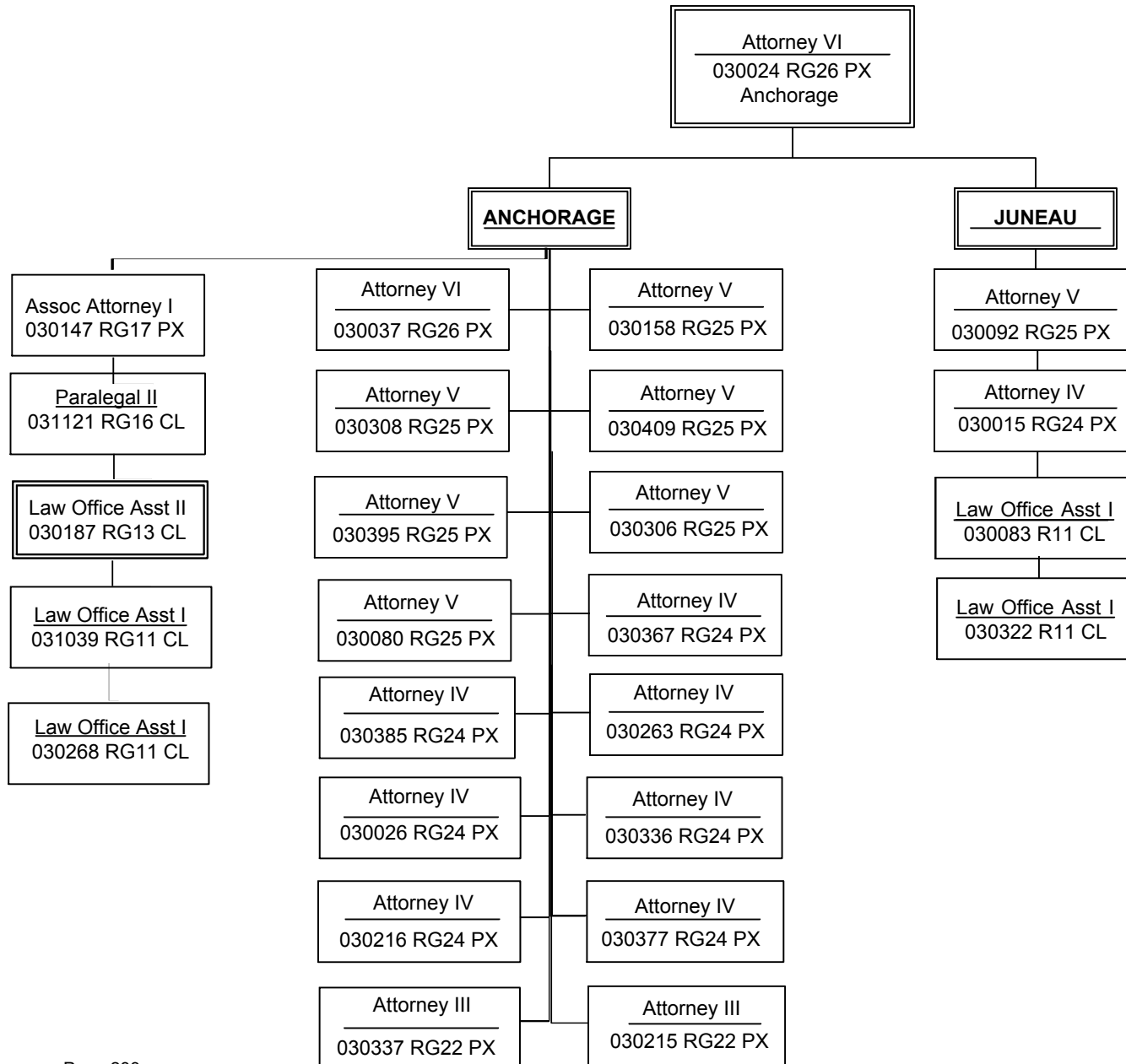

State of Alaska FY2023 Governor's Operating Budget

Department of Law Opinions, Appeals and Ethics Component Budget Summary

Component: Opinions, Appeals and Ethics**Contribution to Department's Mission**

The Opinions, Appeals and Ethics Section represents the State of Alaska and its agencies in civil appeals; provides critical analysis on complex legal questions, and advises the state and its agencies on ethics matters and Native Law issues.

Core Services

- Represent the state and its agencies before the Alaska Supreme Court, Ninth Circuit Court of Appeals, and U.S. Supreme Court, providing the highest level of appellate representation in matters that significantly affect state interests. In addition, section attorneys represent the Department of Health and Social Services in all child protection and civil commitment appeals before the Alaska Supreme Court.
- Assist all attorneys in the Civil Division with appeals and critical motions to ensure consistent legal positions and quality representation.
- Advise the executive branch and its agencies on legal questions that demand the most complex and comprehensive research and analysis.
- Review all Attorney General Opinions prior to publication to ensure clarity, consistency, and completeness in addressing questions of public importance. Section attorneys both draft some Attorney General Opinions and review opinions drafted by other attorneys in the Civil Division.
- Ensure compliance with the Executive Branch Ethics Act by training and advising agencies and individual employees on the Act's requirements and by investigating and resolving ethics complaints. An assistant attorney general in the section serves as the designated ethics supervisor for the Department of Law and legal advisor to ethics supervisors in other agencies, and handles professional ethics issues involving both department staff and outside counsel.
- Provide advice and representation to the state and its agencies on specialized legal issues such as attorneys' fees and Native Law issues.
- Recommend to the Attorney General whether to participate as amicus curiae in appeals before the federal courts, including the United States Supreme Court, in cases that may affect state interests.

Major Component Accomplishments in 2021

- Represented the Department of Health and Social Services in every child protection and civil commitment appeal before the Alaska Supreme Court.
- Reviewed briefs and staffed moot courts in every Civil Division appeal before the Alaska Supreme Court and all federal circuit courts to ensure the highest quality appellate representation for the state.
- Provided critical motion support and strategic counsel to the Civil Division's Special Litigation section in high-profile and complex trial court cases.
- Represented state agencies and officials — including the Department of Natural Resources, the Department of Revenue, the Department of Fish and Game, and the Governor's office — in federal and state court appeals.
- Promoted and enforced compliance with the Alaska Executive Branch Ethics Act by advising individuals and agencies on ethics questions, presenting ethics trainings, drafting ethics opinions and memoranda of advice, and investigating and resolving ethics complaints against former and current state employees.
- Advised state agencies and officials on a wide variety of Native Law issues, including filing an amicus brief in the U.S. Supreme Court in support of Alaska Native Corporations' ability to receive CARES Act funds.

Key Component Challenges

- A key challenge for the section is to lend its expertise in appellate briefing and argument to all Civil Division sections, given the volume of appeals to which the state is a party. At any given time, the Civil Division has between 100 and 150 civil appeals pending, 25-30 of which are child protection cases involving child abuse and neglect. The section directly handles all of the child protection appeals statewide, as well as all appeals of civil commitments statewide. The section also generally handles appeals in cases that concern constitutional and legal issues of particular import. For the rest of the Civil Division's appeals, attorneys in the Opinions, Appeals and Ethics section review and revise appellate briefs drafted by other attorneys and help prepare them for oral argument.
- Because section attorneys have expertise in legal writing and analysis, they are frequently consulted on some of the thorniest and most sensitive legal issues facing state government. Providing this high-quality advice, while maintaining the output required by the Civil Division's heavy appellate caseload, is a challenge.
- The section prepares or reviews Attorney General Opinions.
- The Executive Branch Ethics Act is another key challenge for the section. The section handles issues, investigations, hearings, opinions, and oral and written advice, and also provides ethics training for state agencies. Some matters require significant factual and legal research, and advice must be prompt and consistent. The section's designated ethics attorney frequently works extra hours to ensure that individual and agency clients receive the guidance they need.
- Native Law issues continue to impact virtually every area of state government's responsibilities. The section provides advice on a wide variety of Native Law issues including civil and criminal jurisdiction, trust lands, waivers of sovereign immunity, tribal status, the Indian Child Welfare Act, Public Law 280, and many more. The Civil Division is looking to transfer this knowledge and boost cross-section expertise in this area among other section assistant attorneys general, though it anticipates the ongoing need and unique subject matter of this area of law and provision of legal services will be a continuing challenge for the section.

Significant Changes in Results to be Delivered in FY2023

No changes are anticipated in the coming fiscal year.

Statutory and Regulatory Authority

AS 44.23.020

Contact Information
Contact: Jessie Alloway, Chief Assistant Attorney General Phone: (907) 269-5100 E-mail: jessie.alloway@alaska.gov

Opinions, Appeals and Ethics Personal Services Information				
Authorized Positions			Personal Services Costs	
	<u>FY2022</u> <u>Management</u> <u>Plan</u>	<u>FY2023</u> <u>Governor</u>		
Full-time	13	13	Annual Salaries	1,420,200
Part-time	0	0	Premium Pay	0
Nonpermanent	0	0	Annual Benefits	788,701
			<i>Less 4.00% Vacancy Factor</i>	(88,301)
			Lump Sum Premium Pay	0
Totals	13	13	Total Personal Services	2,120,600

Position Classification Summary					
Job Class Title	Anchorage	Fairbanks	Juneau	Others	Total
Attorney 2	1	0	0	0	1
Attorney 3	1	0	1	0	2
Attorney 5	5	1	1	0	7
Attorney 6	0	0	1	0	1
Law Office Assistant 1	1	0	0	0	1
Paralegal 1	1	0	0	0	1
Totals	9	1	3	0	13

Component Detail All Funds
Department of Law

Component: Opinions, Appeals and Ethics (2716)
RDU: Civil Division (Excludes Janus) (35)

Non-Formula Component

	FY2021 Actuals	FY2022 Conference Committee	FY2022 Authorized	FY2022 Management Plan	FY2023 Governor	FY2022 Management Plan vs FY2023 Governor	
71000 Personal Services	428.6	2,118.8	2,118.8	2,168.8	2,120.6	-48.2	-2.2%
72000 Travel	1.0	21.0	21.0	21.0	21.0	0.0	0.0%
73000 Services	76.7	244.6	244.6	244.6	244.6	0.0	0.0%
74000 Commodities	5.0	0.0	0.0	0.0	0.0	0.0	0.0%
75000 Capital Outlay	1.7	0.0	0.0	0.0	0.0	0.0	0.0%
77000 Grants, Benefits	0.0	0.0	0.0	0.0	0.0	0.0	0.0%
78000 Miscellaneous	0.0	0.0	0.0	0.0	0.0	0.0	0.0%
Totals	513.0	2,384.4	2,384.4	2,434.4	2,386.2	-48.2	-2.0%
Fund Sources:							
1004 Gen Fund (UGF)	513.0	1,406.0	1,406.0	1,406.0	1,347.1	-58.9	-4.2%
1007 I/A Rcpts (Other)	0.0	978.4	978.4	1,028.4	1,039.1	10.7	1.0%
Unrestricted General (UGF)	513.0	1,406.0	1,406.0	1,406.0	1,347.1	-58.9	-4.2%
Designated General (DGF)	0.0	0.0	0.0	0.0	0.0	0.0	0.0%
Other Funds	0.0	978.4	978.4	1,028.4	1,039.1	10.7	1.0%
Federal Funds	0.0	0.0	0.0	0.0	0.0	0.0	0.0%
Positions:							
Permanent Full Time	13	13	13	13	13	0	0.0%
Permanent Part Time	0	0	0	0	0	0	0.0%
Non Permanent	0	0	0	0	0	0	0.0%

Change Record Detail - Multiple Scenarios with Descriptions
Department of Law

Component: Opinions, Appeals and Ethics (2716)
RDU: Civil Division (Excludes Janus) (35)

Scenario/Change Record Title	Trans Type	Totals	Personal Services	Travel	Services	Commodities	Capital Outlay	Grants, Benefits	Miscellaneous	Positions		
										PFT	PPT	NP
***** Changes From FY2022 Conference Committee To FY2022 Authorized *****												
FY2022 Conference Committee												
	ConfCom	2,384.4	2,118.8	21.0	244.6	0.0	0.0	0.0	0.0	13	0	0
1004 Gen Fund		1,406.0										
1007 I/A Rcpts		978.4										
Subtotal		2,384.4	2,118.8	21.0	244.6	0.0	0.0	0.0	0.0	13	0	0
***** Changes From FY2022 Authorized To FY2022 Management Plan *****												
Transfer Law Office Assistant 2 (03-0208) to Special Litigation to Address Workload Demands												
	Trout	0.0	0.0	0.0	0.0	0.0	0.0	0.0	0.0	-1	0	0
Transfer a full-time Law Office Assistant 2 (03-0208), range 13, located in Anchorage, to the Special Litigation component from the Opinions, Appeals and Ethics component to accommodate workload demands. The remaining staff in the Opinions, Appeals and Ethics are sufficient to cover the anticipated workload.												
Transfer Attorney 2 (03-0379) to Environmental Law for Required Legal Expertise												
	Trout	0.0	0.0	0.0	0.0	0.0	0.0	0.0	0.0	-1	0	0
Transfer one full-time Attorney 2 position (03-0379), range 20, located in Anchorage, to the Environmental Law component from the Opinions, Appeals and Ethics component from the to keep pace with the required level of legal expertise needed within the office. The remaining staff in Opinions, Appeals and Ethics are sufficient to accommodate anticipated workload.												
Transfer Attorney 5 (03-0413) from Child Protection for Required Legal Expertise												
	Trin	50.0	50.0	0.0	0.0	0.0	0.0	0.0	0.0	1	0	0
1007 I/A Rcpts		50.0										
Transfer one full-time Attorney 5 position (03-0413), range 25, located in Anchorage, to the Opinions, Appeals and Ethics component from the Child Protection component to keep pace with the required level of legal expertise needed within the office. The remaining staff in Child Protection are sufficient to accommodate anticipated workload.												
Transfer Law Office Assistant 1 (03-0270) from Special Litigation to Address Workload Demands												
	Trin	0.0	0.0	0.0	0.0	0.0	0.0	0.0	0.0	1	0	0
Transfer a full-time Law Office Assistant 1 (03-0270), range 11, located in Anchorage, from the Special Litigation component to the Opinions, Appeals and Ethics component to accommodate workload demands. The remaining staff in the Special Litigation are sufficient to cover the anticipated workload.												
Subtotal		2,434.4	2,168.8	21.0	244.6	0.0	0.0	0.0	0.0	13	0	0
***** Changes From FY2022 Management Plan To FY2023 Governor *****												
FY2023 Executive Health Insurance, SBS, and Risk Management Rate Changes												
	SalAdj	21.5	21.5	0.0	0.0	0.0	0.0	0.0	0.0	0	0	0

Change Record Detail - Multiple Scenarios with Descriptions
Department of Law

Component: Opinions, Appeals and Ethics (2716)
RDU: Civil Division (Excludes Janus) (35)

Scenario/Change Record Title	Trans Type	Totals	Personal Services	Travel	Services	Commodities	Capital Outlay	Grants, Benefits	Miscellaneous	Positions		NP
										PFT	PPT	
1004 Gen Fund		10.8										
1007 I/A Rcpts		10.7										
FY2023 Change Partially Exempt & Exempt Executive (EE) - Health Insurance from \$1,555 to \$1,685; SBS and Risk Management Rates: \$21.5												
FY2023 General Government Unit SBS and Risk Management Rate Changes												
	SalAdj	0.3	0.3	0.0	0.0	0.0	0.0	0.0	0.0	0	0	0
1004 Gen Fund		0.3										
FY2023 Change General Government Unit (GG, GP, GY, GZ) - SBS, and Risk Management Rates: \$0.3												
FY2023 PERS Actuarial Rate Adjustment to 24.79% Ch9 SLA2021 (SB55)												
	SalAdj	-70.0	-70.0	0.0	0.0	0.0	0.0	0.0	0.0	0	0	0
1004 Gen Fund		-37.4										
1007 I/A Rcpts		-32.6										
Includes: FY2023 Adjustment for PERS ARM Board Approved Rate of 24.79% (from 30.11%): \$-70.0												
Realign PERS Rate Adjustment by Fund Source Ch9 SLA2021 (SB55)												
	FndChg	0.0	0.0	0.0	0.0	0.0	0.0	0.0	0.0	0	0	0
1004 Gen Fund		-32.6										
1007 I/A Rcpts		32.6										
Remove one-time UGF subsidy for rate agency assigned in SB55 fiscal note (Ch 9 SLA 2021).												
Totals		2,386.2	2,120.6	21.0	244.6	0.0	0.0	0.0	0.0	13	0	0

Line Item Detail (1676)
Department of Law
Travel

Component: Opinions, Appeals and Ethics (2716)

Line Number	Line Name		FY2021 Actuals	FY2022 Management Plan	FY2023 Governor
2000	Travel		1.0	21.0	21.0
Object Class	Servicing Agency	Explanation	FY2021 Actuals	FY2022 Management Plan	FY2023 Governor
2000 Travel Detail Totals			1.0	21.0	21.0
2000	In-State Employee Travel	Travel for attorneys to interview witnesses and attend court proceedings, as well as for necessary training for both attorneys and paraprofessionals. Includes travel for management purposes.	0.0	11.0	11.0
2006	Other Travel Costs	Travel cost transfers.	1.0	10.0	10.0

Line Item Detail (1676)
Department of Law
Services

Component: Opinions, Appeals and Ethics (2716)

Line Number	Line Name		FY2021 Actuals	FY2022 Management Plan	FY2023 Governor
3000	Services		76.7	244.6	244.6
Object Class	Servicing Agency	Explanation	FY2021 Actuals	FY2022 Management Plan	FY2023 Governor
3000 Services Detail Totals			76.7	244.6	244.6
3000	Education Services	Conferences, training and memberships.	7.3	10.0	10.0
3002	Legal and Judicial Services	Depositions, research costs, expert witness and consultant fees.	0.0	1.0	1.0
3006	Delivery Services	Freight, courier, postage, and transportation of trial exhibit materials.	0.1	0.1	0.1
3007	Advertising and Promotions	Publication of legal notices.	0.0	0.5	0.5
3011	Other Services	Cost transfers and miscellaneous items within the services line (commissions, etc.).	69.3	233.0	233.0

Line Item Detail (1676)
Department of Law
Commodities

Component: Opinions, Appeals and Ethics (2716)

Line Number	Line Name		FY2021 Actuals	FY2022 Management Plan	FY2023 Governor
4000	Commodities		5.0	0.0	0.0
Object Class	Servicing Agency	Explanation	FY2021 Actuals	FY2022 Management Plan	FY2023 Governor
4000 Commodities Detail Totals			5.0	0.0	0.0
4022	Commodity Transfer	Commodity cost transfers.	5.0	0.0	0.0

Line Item Detail (1676)
Department of Law
Capital Outlay

Component: Opinions, Appeals and Ethics (2716)

Line Number	Line Name		FY2021 Actuals	FY2022 Management Plan	FY2023 Governor
5000	Capital Outlay		1.7	0.0	0.0
Object Class	Servicing Agency	Explanation	FY2021 Actuals	FY2022 Management Plan	FY2023 Governor
5000 Capital Outlay Detail Totals			1.7	0.0	0.0
5009	Capital Outlay Transfer	Capital cost transfers.	1.7	0.0	0.0

Revenue Detail (1681)
Department of Law

Component: Opinions, Appeals and Ethics (2716)

Revenue Type (OMB Fund Code) Revenue Source	Component	Comment	FY2021 Actuals	FY2022 Management Plan	FY2023 Governor
5007 I/A Rcpts (1007 I/A Rcpts)			0.0	1,028.4	1,039.1
5301 Inter-Agency Receipts	Law - Opinions, Appeals and Ethics (2716)	Interagency receipts - the Opinions, Appeals and Ethics component provides senior-level analysis and specialized legal services and representation to state government on all legal opinions, civil appeals in state and federal court, all executive branch ethics, public finance matters, and Native Alaskan/Indian Law matters. Billable time is charged directly to the case/matter of reimbursable service agreements throughout the Civil Division.	0.0	1,028.4	1,039.1

Personal Services Expenditure Detail
Department of Law

Scenario: FY2023 Governor (18673)
Component: Opinions, Appeals and Ethics (2716)
RDU: Civil Division (Excludes Janus) (35)

PCN	Job Class Title	Time Status	Retire Code	Barg Unit	Location	Salary Sched	Range / Step	Comp Months	Split / Count	Annual Salaries	COLA	Premium Pay	Annual Benefits	Total Costs	UGF Amount
03-0007	Attorney 5	FT	A	XE	Anchorage	N00	25J	12.0		118,131	0	0	64,217	182,348	0
03-0048	Attorney 5	FT	A	XE	Fairbanks	99	25R	12.0		162,560	0	0	79,786	242,346	181,760
03-0057	Paralegal 1	FT	A	GP	Anchorage	200	14G / J	12.0		57,066	0	0	40,027	97,093	97,093
03-0203	Attorney 3	FT	A	XE	Anchorage	N00	22E / F	12.0		90,007	0	0	53,747	143,754	107,816
03-0204	Law Office Assistant 1	FT	A	GP	Fairbanks	203	11B	6.0	*	20,144	0	0	16,890	37,034	7,407
03-0270	Law Office Assistant 1	FT	A	GP	Anchorage	200	11B / C	12.0		39,497	0	0	33,486	72,983	72,983
03-0295	Attorney 5	FT	A	XE	Juneau	N05	25F	12.0		120,140	0	0	64,965	185,105	138,829
03-0316	Attorney 2	FT	N	XE	Anchorage	N00	20C / D	12.0		75,626	0	0	29,645	105,271	52,636
03-0325	Attorney 3	FT	A	XE	Juneau	N05	22F	12.0		97,617	0	0	56,580	154,197	100,228
03-0338	Attorney 6	FT	A	XE	Juneau	N05	26C / D	12.0		115,154	0	0	63,109	178,263	133,697
03-0342	Attorney 5	FT	A	XE	Anchorage	N00	25M	12.0		130,026	0	0	68,646	198,672	99,336
03-0380	Attorney 5	FT	A	XE	Anchorage	N00	25K	12.0		121,973	0	0	65,648	187,621	0
03-0392	Associate Attorney 2	FT	A	XE	Anchorage	N00	19M	6.0	*	43,407	0	0	26,279	69,686	45,296
03-0408	Attorney 5	FT	A	XE	Anchorage	N00	25F	12.0		114,426	0	0	62,838	177,264	132,948
03-0413	Attorney 5	FT	A	XE	Anchorage	N00	25F	12.0		114,426	0	0	62,838	177,264	0
													Total Salary Costs:	1,420,200	
													Total COLA:	0	
													Total Premium Pay:	0	
													Total Benefits:	788,701	
													Total Pre-Vacancy:	2,208,901	
													Minus Vacancy Adjustment of 4.00%:	(88,301)	
													Total Post-Vacancy:	2,120,600	
													Plus Lump Sum Premium Pay:	0	
													Personal Services Line 100:	2,120,600	
Total Component Months:		168.0													

PCN Funding Sources:	Pre-Vacancy	Post-Vacancy	Percent
1004 General Fund Receipts	1,170,027	1,123,255	52.97%
1007 Interagency Receipts	1,038,874	997,345	47.03%
Total PCN Funding:	2,208,901	2,120,600	100.00%

Note: If a position is split, an asterisk (*) will appear in the Split/Count column. If the split position is also counted in the component, two asterisks (**) will appear in this column. [No valid job title] appearing in the Job Class Title indicates that the PCN has an invalid class code or invalid range for the class code effective date of this scenario.

CIVIL DIVISION

Opinions, Appeals and Ethics

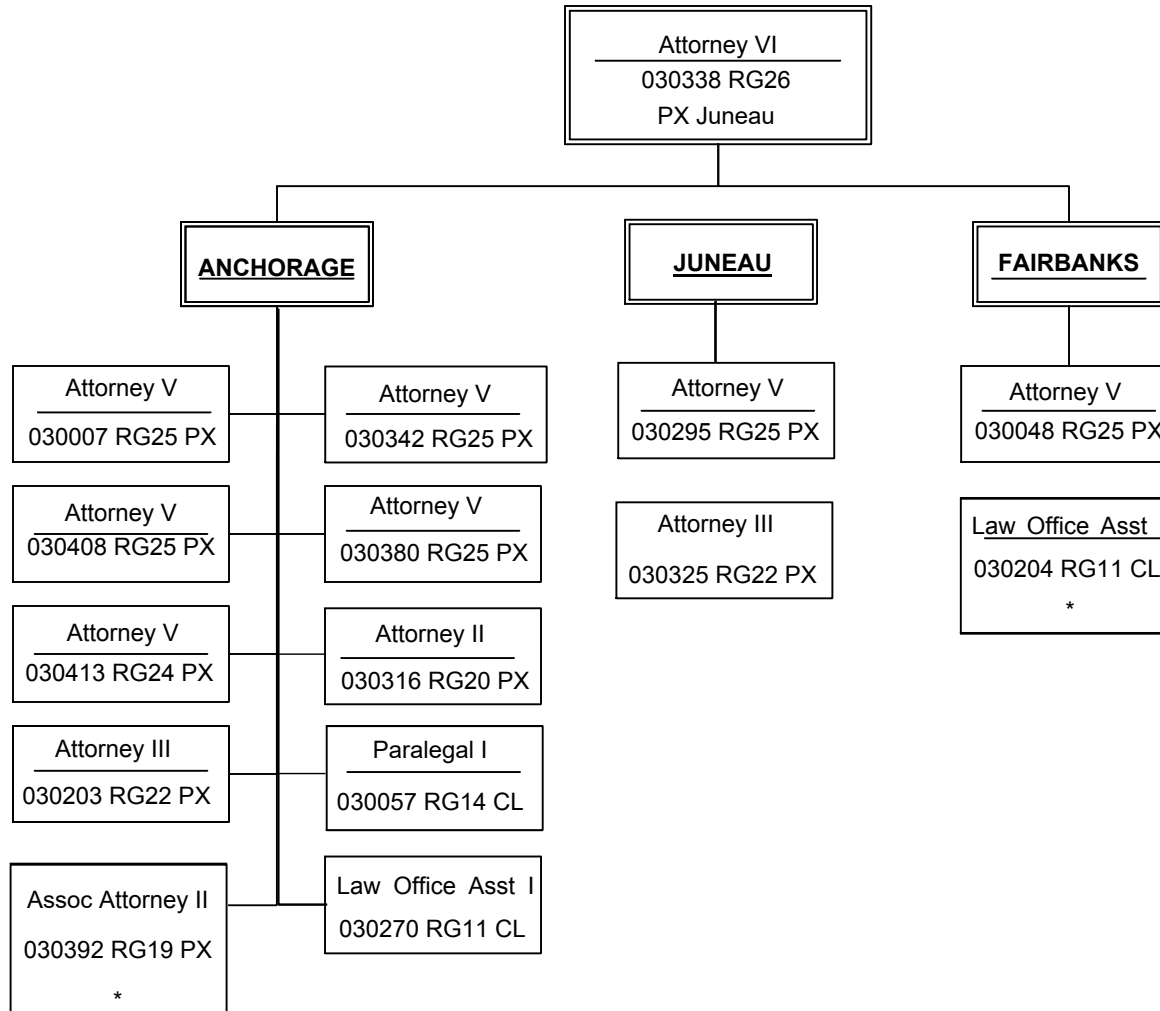

Position Count: 13

State of Alaska FY2023 Governor's Operating Budget

Department of Law Regulatory Affairs Public Advocacy Component Budget Summary

Component: Regulatory Affairs Public Advocacy**Contribution to Department's Mission**

The Regulatory Affairs and Public Advocacy (RAPA) Section exercises the Attorney General's responsibility to represent the public interest in utility and pipeline matters before the Regulatory Commission of Alaska (RCA).

Core Services

- RAPA advocates for the public interest in matters before the RCA, paying particular attention to the interests of consumers who would not otherwise have an effective voice regarding the rates and services of regulated utilities and pipeline carriers operating in the state.

Major Component Accomplishments in 2021

RAPA helps ensure that utility and pipeline carrier tariff rates and service practices are just and reasonable. Approximately \$1.5 million in quantifiable consumer benefits can be tracked to RAPA advocacy in FY2021. This is based on the difference between the amounts that utilities requested in their revenue requirement proposals and the amounts that the RCA ultimately awarded to them. To achieve these results in FY2021, the department expended approximately \$2.39 million in RCA regulatory cost charge receipts, collected from utilities.

During FY2021, RAPA participated in over thirty dockets. RAPA's work includes filing testimony, participating in public hearings, filing comments in rulemakings, and completing stipulations to settle cases.

Example of an FY2021 docket where RAPA participated:

- Participation in Golden Heart Utilities rate case that resulted in approximately \$1.5 million reduction in the utilities' requested revenue requirement. The RCA's decision is currently on appeal.

RAPA also investigates and participates in RCA "rulemaking" dockets that affect utility and pipeline carrier practices or services on a statewide basis. For instance, RAPA continues to be involved in the implementation of regulations required by SB 123 (SLA 2021). SB 123 requires the creation of an Electric Reliability Organization to develop and implement reliability standards for the safe and efficient operation of an interconnected bulk-energy system. Currently, the only interconnected bulk-energy system implicated is the Railbelt electric grid that serves customers from Fairbanks to Homer.

Key Component Challenges

During the upcoming fiscal year, RAPA will continue to represent the public interest on behalf of the Attorney General in proceedings before the RCA. RAPA will investigate public utility and pipeline carrier proposals that come before the RCA, file testimony, litigate cases, and defend RAPA positions before the RCA and on appeal as appropriate.

One significant ongoing challenge facing RAPA is providing quality continuing education in public utility ratemaking for non-attorney professional analysts/expert witnesses.

Significant Changes in Results to be Delivered in FY2023

No significant changes are anticipated in the upcoming fiscal year.

Statutory and Regulatory Authority

AS 44.23.020(e)

Contact Information

Contact: Jeff Waller, Chief Assistant Attorney General
Phone: (907) 269-5100
E-mail: jeff.waller@alaska.gov

Regulatory Affairs Public Advocacy Personal Services Information				
Authorized Positions			Personal Services Costs	
	<u>FY2022</u> <u>Management</u> <u>Plan</u>	<u>FY2023</u> <u>Governor</u>		
Full-time	10	10	Annual Salaries	1,010,147
Part-time	0	0	COLA	1,969
Nonpermanent	0	0	Premium Pay	0
			Annual Benefits	569,485
			<i>Less 2.69% Vacancy Factor</i>	(42,501)
			Lump Sum Premium Pay	0
Totals	10	10	Total Personal Services	1,539,100

Position Classification Summary					
Job Class Title	Anchorage	Fairbanks	Juneau	Others	Total
Attorney 4	1	0	0	0	1
Attorney 5	1	0	0	0	1
Attorney 6	1	0	0	0	1
Law Office Assistant 1	2	0	0	0	2
Public Aua 1	4	0	0	0	4
Public Aua 2	1	0	0	0	1
Totals	10	0	0	0	10

Component Detail All Funds
Department of Law

Component: Regulatory Affairs Public Advocacy (2764)
RDU: Civil Division (Excludes Janus) (35)

Non-Formula Component

	FY2021 Actuals	FY2022 Conference Committee	FY2022 Authorized	FY2022 Management Plan	FY2023 Governor	FY2022 Management Plan vs FY2023 Governor	
71000 Personal Services	1,481.6	1,465.7	1,465.7	1,580.7	1,539.1	-41.6	-2.6%
72000 Travel	1.1	20.0	20.0	20.0	20.0	0.0	0.0%
73000 Services	902.1	1,429.3	1,429.3	1,314.3	1,314.3	0.0	0.0%
74000 Commodities	5.9	18.8	18.8	18.8	18.8	0.0	0.0%
75000 Capital Outlay	2.0	0.0	0.0	0.0	0.0	0.0	0.0%
77000 Grants, Benefits	0.0	0.0	0.0	0.0	0.0	0.0	0.0%
78000 Miscellaneous	0.0	0.0	0.0	0.0	0.0	0.0	0.0%
Totals	2,392.7	2,933.8	2,933.8	2,933.8	2,892.2	-41.6	-1.4%
Fund Sources:							
1004 Gen Fund (UGF)	1.6	458.1	458.1	458.1	456.0	-2.1	-0.5%
1141 RCA Rcpts (DGF)	2,391.1	2,475.7	2,475.7	2,475.7	2,436.2	-39.5	-1.6%
Unrestricted General (UGF)	1.6	458.1	458.1	458.1	456.0	-2.1	-0.5%
Designated General (DGF)	2,391.1	2,475.7	2,475.7	2,475.7	2,436.2	-39.5	-1.6%
Other Funds	0.0	0.0	0.0	0.0	0.0	0.0	0.0%
Federal Funds	0.0	0.0	0.0	0.0	0.0	0.0	0.0%
Positions:							
Permanent Full Time	9	9	9	10	10	0	0.0%
Permanent Part Time	0	0	0	0	0	0	0.0%
Non Permanent	0	0	0	0	0	0	0.0%

Change Record Detail - Multiple Scenarios with Descriptions
Department of Law

Component: Regulatory Affairs Public Advocacy (2764)
RDU: Civil Division (Excludes Janus) (35)

Scenario/Change Record Title	Trans Type	Totals	Personal Services	Travel	Services	Commodities	Capital Outlay	Grants, Benefits	Miscellaneous	Positions		NP
										PFT	PPT	
***** Changes From FY2022 Conference Committee To FY2022 Authorized *****												
FY2022 Conference Committee												
	ConfCom	2,933.8	1,465.7	20.0	1,429.3	18.8	0.0	0.0	0.0	9	0	0
1004 Gen Fund		458.1										
1141 RCA Rcpts		2,475.7										
Subtotal		2,933.8	1,465.7	20.0	1,429.3	18.8	0.0	0.0	0.0	9	0	0
***** Changes From FY2022 Authorized To FY2022 Management Plan *****												
Add Attorney 4 for Regulatory and Public Advocacy Work												
	PosAdj	0.0	0.0	0.0	0.0	0.0	0.0	0.0	0.0	1	0	0
Add Attorney 4 for regulatory and public advocacy work in the Regulatory and Public Advocacy component of the Civil Division.												
Transfer Authority from Services for Anticipated Personal Service Expenditures												
	LIT	0.0	115.0	0.0	-115.0	0.0	0.0	0.0	0.0	0	0	0
Transfer authority from the services line to the personal services line for anticipated personal services costs. The remaining services authority is anticipated to be sufficient to cover operating expenditures.												
Subtotal		2,933.8	1,580.7	20.0	1,314.3	18.8	0.0	0.0	0.0	10	0	0
***** Changes From FY2022 Management Plan To FY2023 Governor *****												
FY2023 Salary and Benefit Adjustments												
	SalAdj	2.0	2.0	0.0	0.0	0.0	0.0	0.0	0.0	0	0	0
1141 RCA Rcpts		2.0										
FY2023 SU BU - Supervisory Employees (SS) 1% COLA: \$2.0												
FY2023 Executive Health Insurance, SBS, and Risk Management Rate Changes												
	SalAdj	5.8	5.8	0.0	0.0	0.0	0.0	0.0	0.0	0	0	0
1004 Gen Fund		0.4										
1141 RCA Rcpts		5.4										
FY2023 Change Partially Exempt & Exempt Executive (EE) - Health Insurance from \$1,555 to \$1,685; SBS and Risk Management Rates: \$5.8												
FY2023 Supervisory Employees Health Insurance, SBS, and Risk Management Rate Changes												
	SalAdj	2.2	2.2	0.0	0.0	0.0	0.0	0.0	0.0	0	0	0
1141 RCA Rcpts		2.2										
FY2023 Change Supervisory Employees (SS) - Health Insurance from \$1,555 to \$1,685; SBS and Risk Management Rates: \$2.2												

Change Record Detail - Multiple Scenarios with Descriptions
Department of Law

Component: Regulatory Affairs Public Advocacy (2764)
RDU: Civil Division (Excludes Janus) (35)

Scenario/Change Record Title	Trans Type	Totals	Personal Services	Travel	Services	Commodities	Capital Outlay	Grants, Benefits	Miscellaneous	Positions		NP
										PFT	PPT	
FY2023 General Government Unit SBS and Risk Management Rate Changes												
	SalAdj	1.4	1.4	0.0	0.0	0.0	0.0	0.0	0.0	0	0	0
1004 Gen Fund		0.1										
1141 RCA Rcpts		1.3										
FY2023 Change General Government Unit (GG, GP, GY, GZ) - SBS, and Risk Management Rates: \$1.4												
FY2023 PERS Actuarial Rate Adjustment to 24.79% Ch9 SLA2021 (SB55)												
	SalAdj	-53.0	-53.0	0.0	0.0	0.0	0.0	0.0	0.0	0	0	0
1004 Gen Fund		-2.6										
1141 RCA Rcpts		-50.4										
Includes: FY2023 Adjustment for PERS ARM Board Approved Rate of 24.79% (from 30.11%): \$-53.0												
Totals		2,892.2	1,539.1	20.0	1,314.3	18.8	0.0	0.0	0.0	10	0	0

Line Item Detail (1676)
Department of Law
Travel

Component: Regulatory Affairs Public Advocacy (2764)

Line Number	Line Name		FY2021 Actuals	FY2022 Management Plan	FY2023 Governor
2000	Travel		1.1	20.0	20.0
Object Class	Servicing Agency	Explanation	FY2021 Actuals	FY2022 Management Plan	FY2023 Governor
2000 Travel Detail Totals			1.1	20.0	20.0
2000	In-State Employee Travel	Travel for attorneys to interview witnesses and attend court proceedings, as well as for necessary training for both attorneys and paraprofessionals. Includes travel for management purposes.	0.0	3.2	3.2
2001	In-State Non-Employee Travel	Travel costs for witnesses to testify in court.	0.0	5.0	5.0
2002	Out of State Employee Travel	Travel costs and expenses for out-of-state travel for conferences, training, etc.	0.0	10.7	10.7
2006	Other Travel Costs	Travel cost transfers.	1.1	1.1	1.1

Line Item Detail (1676)
Department of Law
Services

Component: Regulatory Affairs Public Advocacy (2764)

Line Number	Line Name			FY2021 Actuals	FY2022 Management Plan	FY2023 Governor
3000	Services			902.1	1,314.3	1,314.3
Object Class	Servicing Agency	Explanation		FY2021 Actuals	FY2022 Management Plan	FY2023 Governor
3000 Services Detail Totals				902.1	1,314.3	1,314.3
3000	Education Services	Conferences, training and memberships.		21.3	22.5	22.5
3002	Legal and Judicial Services	Depositions, research costs, expert witness and consultant fees.		116.4	200.0	200.0
3003	Information Technology	Training, consulting and software licensing and maintenance. Annual maintenance fee for mission-critical information management systems.		0.4	5.0	5.0
3011	Other Services	Cost transfers and miscellaneous items within the services line (commissions, etc.).		696.1	1,010.1	1,010.1
3013	Inter-Agency Data Processing Operations Allocation	Law - Administrative Services (2164)	RSA Law, Information services, data processing investments and support.	2.2	2.4	2.4
3017	Inter-Agency Information Technology Non-Telecommunications	Admin - Department-wide	RSA Administration, Office of Information Technology computer services.	24.0	31.2	31.2
3018	Inter-Agency Information Technology Telecommunications	Admin - Department-wide	RSA Administration, Office of Information Technology telecommunications services.	3.1	3.5	3.5
3022	Inter-Agency Human Resources	Law - Administrative Services (2164)	RSA Law, Human Resources position.	5.4	5.6	5.6
3023	Inter-Agency Building Leases	Admin - Department-wide	Leased office space managed by General Services.	32.3	33.0	33.0
3026	Inter-Agency Insurance	Admin - Department-wide	RSA Administration, Risk Management.	0.4	0.4	0.4
3027	Inter-Agency Financial	Admin - Department-wide	RSA Administration, Finance	0.4	0.5	0.5

Line Item Detail (1676)
Department of Law
Services

Component: Regulatory Affairs Public Advocacy (2764)

Object Class	Servicing Agency	Explanation	FY2021 Actuals	FY2022 Management Plan	FY2023 Governor
3000 Services Detail Totals			902.1	1,314.3	1,314.3
		Chargeback (IRIS).			
3028	Inter-Agency Americans with Disabilities Act Compliance	RSA Administration - Division of Personnel and Labor Relations, Americans with Disabilities Act.	0.1	0.1	0.1

Line Item Detail (1676)
Department of Law
Commodities

Component: Regulatory Affairs Public Advocacy (2764)

Line Number	Line Name		FY2021 Actuals	FY2022 Management Plan	FY2023 Governor
4000	Commodities		5.9	18.8	18.8
Object Class	Servicing Agency	Explanation	FY2021 Actuals	FY2022 Management Plan	FY2023 Governor
4000 Commodities Detail Totals			5.9	18.8	18.8
4000	Business	Reference materials and subscriptions, including statutes, software applications, non-capital desktop refresh, and miscellaneous office supplies.	0.2	2.6	2.6
4022	Commodity Transfer	Commodity cost transfers.	5.7	16.2	16.2

Line Item Detail (1676)
Department of Law
Capital Outlay

Component: Regulatory Affairs Public Advocacy (2764)

Line Number	Line Name		FY2021 Actuals	FY2022 Management Plan	FY2023 Governor
5000	Capital Outlay		2.0	0.0	0.0
Object Class	Servicing Agency	Explanation	FY2021 Actuals	FY2022 Management Plan	FY2023 Governor
5000 Capital Outlay Detail Totals			2.0	0.0	0.0
5009	Capital Outlay Transfer	Capital cost transfers.	2.0	0.0	0.0

Revenue Detail (1681)
Department of Law

Component: Regulatory Affairs Public Advocacy (2764)

Revenue Type (OMB Fund Code)				FY2022	
Revenue Source	Component	Comment	FY2021 Actuals	Management Plan	FY2023 Governor
5141 RCA Rcpts (1141 RCA Rcpts)			2,391.1	2,475.7	2,436.2
5402 Regulatory Commission of Alaska Receipts		Regulatory Commission of Alaska - Expert technical support of Regulatory Affairs and Public Advocacy non-attorney professionals who provide accounting, engineering, economic and policy analysis for all types of regulated utilities and preparation of written testimony for hearings.	2,391.1	2,475.7	2,436.2

Inter-Agency Services (1682)
Department of Law

Component: Regulatory Affairs Public Advocacy (2764)

				FY2021 Actuals	FY2022 Management Plan	FY2023 Governor
Component Totals				67.8	76.6	76.6
With Department of Law				7.6	8.0	8.0
With Department of Administration				60.2	68.6	68.6
Object Class	Servicing Agency	Explanation		FY2021 Actuals	FY2022 Management Plan	FY2023 Governor
3013	Inter-Agency Data Processing Operations Allocation	Law - Administrative Services (2164)	RSA Law, Information services, data processing investments and support.	2.2	2.4	2.4
3017	Inter-Agency Information Technology Non-Telecommunications	Admin - Department-wide	RSA Administration, Office of Information Technology computer services.	24.0	31.2	31.2
3018	Inter-Agency Information Technology Telecommunications	Admin - Department-wide	RSA Administration, Office of Information Technology telecommunications services.	3.1	3.5	3.5
3022	Inter-Agency Human Resources	Law - Administrative Services (2164)	RSA Law, Human Resources position.	5.4	5.6	5.6
3023	Inter-Agency Building Leases	Admin - Department-wide	Leased office space managed by General Services.	32.3	33.0	33.0
3026	Inter-Agency Insurance	Admin - Department-wide	RSA Administration, Risk Management.	0.4	0.4	0.4
3027	Inter-Agency Financial	Admin - Department-wide	RSA Administration, Finance Chargeback (IRIS).	0.4	0.5	0.5

Personal Services Expenditure Detail
Department of Law

Scenario: FY2023 Governor (18673)
Component: Regulatory Affairs Public Advocacy (2764)
RDU: Civil Division (Excludes Janus) (35)

PCN	Job Class Title	Time Status	Retire Code	Barg Unit	Location	Salary Sched	Range / Step	Comp Months	Split / Count	Annual Salaries	COLA	Premium Pay	Annual Benefits	Total Costs	UGF Amount
03-0063	Law Office Assistant 1	FT	A	GP	Anchorage	200	11K / L	12.0		49,164	0	0	37,085	86,249	21,562
03-0103	Attorney 4	FT	A	XE	Anchorage	N00	24J	12.0		109,902	0	0	61,154	171,056	34,211
03-0108	Attorney 6	FT	A	XE	Anchorage	N00	26P / Q	12.0		149,262	0	0	75,650	224,912	0
03-0424	Public Aua 1	FT	A	GP	Anchorage	200	22K / L	12.0		105,341	0	0	58,000	163,341	0
03-0431	Attorney 5	FT	A	XE	Anchorage	N00	25F	12.0		114,426	0	0	62,838	177,264	0
08-6028	Public Aua 1	FT	A	GP	Anchorage	200	22N	12.0		114,407	0	0	61,375	175,782	0
08-6045	Public Aua 2	FT	A	SS	Anchorage	99	24Q	12.0		150,225	1,969	0	76,094	228,288	0
08-6071	Public Aua 1	FT	A	GP	Anchorage	200	22C / D	12.0		86,026	0	0	50,809	136,835	0
08-6073	Public Aua 1	FT	A	GP	Anchorage	200	22A / B	12.0		80,830	0	0	48,874	129,704	0
08-6079	Law Office Assistant 1	FT	A	GP	Anchorage	200	11L	12.0		50,564	0	0	37,606	88,170	26,451
													Total Salary Costs:	1,010,147	
													Total COLA:	1,969	
													Total Premium Pay:	0	
													Total Benefits:	569,485	
													Total Pre-Vacancy:	1,581,601	
													Minus Vacancy Adjustment of 2.69%:	(42,501)	
													Total Post-Vacancy:	1,539,100	
													Plus Lump Sum Premium Pay:	0	
													Personal Services Line 100:	1,539,100	

PCN Funding Sources:	Pre-Vacancy	Post-Vacancy	Percent
1004 General Fund Receipts	82,224	80,015	5.20%
1141 RCA Receipts	1,499,377	1,459,085	94.80%
Total PCN Funding:	1,581,601	1,539,100	100.00%

Note: If a position is split, an asterisk (*) will appear in the Split/Count column. If the split position is also counted in the component, two asterisks (**) will appear in this column. [No valid job title] appearing in the Job Class Title indicates that the PCN has an invalid class code or invalid range for the class code effective date of this scenario.

CIVIL DIVISION

Regulatory Affairs and Public Advocacy

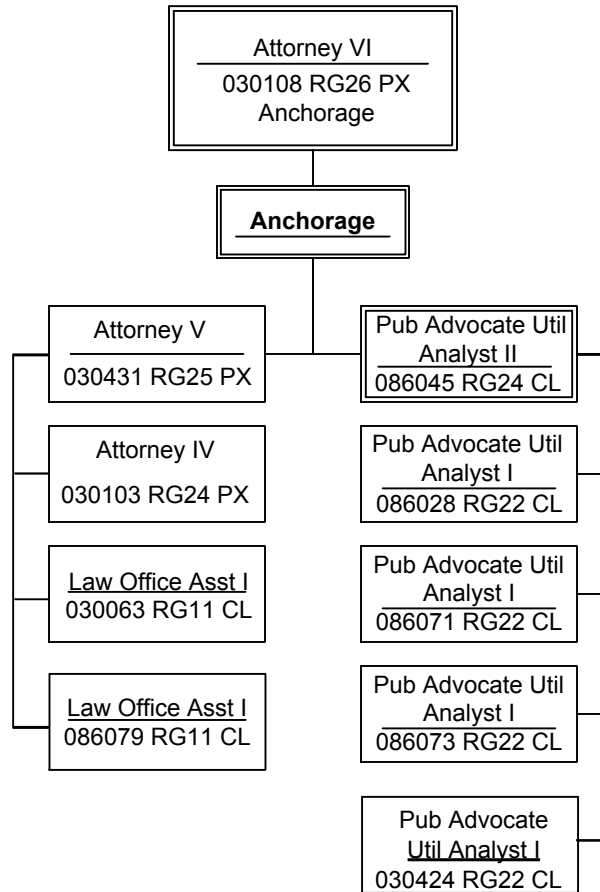

**State of Alaska
FY2023 Governor's Operating Budget**

**Department of Law
Special Litigation
Component Budget Summary**

Component: Special Litigation**Contribution to Department's Mission**

The Special Litigation Section provides specialized legal services and representation to state government, taking major civil cases to trial in state and federal court and administrative proceedings. It also enforces the state's consumer protection statutes.

Core Services

- The section enforces state consumer protection and antitrust laws and provides legal services and expertise to departments and agencies faced with major litigation involving large-scale discovery, constitutional challenges, or expedited proceedings.
- Section attorneys lead litigation teams of experienced litigators, appellate specialists, and subject matter experts from other sections to provide the state with the strongest possible representation in complex and important litigation.
- Section attorneys serve as a resource for attorneys in other sections, offering advice and assistance in all stages of litigation.

Major Component Accomplishments in 2021

The section's attorneys have led litigation teams representing a variety of state agencies, including the executive branch departments of Administration, Natural Resources, and Health and Social Services, as well as the Governor's Office and the Division of Elections.

The section continues to manage a variety of cases against pharmaceutical companies — both multistate cases involving anti-trust violations and the state's consumer protection complaints against opioid manufacturers and distributors. The section is also working with multistate groups in antitrust actions against Google, and with outside counsel to pursue price-fixing claims in the meat industry.

The Consumer Protection Unit has brought a number of successful enforcement actions this year and continues to investigate a variety of consumer complaints.

The section continues to provide litigation expertise in support of major cases in other sections.

Key Component Challenges

The purpose of the section is to provide a formal structure to the Civil Division's former ad hoc approach to team building, with the expertise of the Special Litigation team at the center. Just as the Opinions, Appeals and Ethics Section functions as a service section for other sections in the division—providing appellate specialists to handle appeals or expert appellate advice to subject matter attorneys—the Special Litigation section provides trial expertise and guidance in cases for every section.

Significant Changes in Results to be Delivered in FY2023

No changes are anticipated in the coming fiscal year.

Statutory and Regulatory Authority

AS 44.23.020

Contact Information

Contact Information

Contact: Margaret Paton-Walsh, Chief Assistant Attorney General
Phone: (907) 269-5100
E-mail: margaret.paton-walsh@alaska.gov

Special Litigation Personal Services Information				
Authorized Positions			Personal Services Costs	
	<u>FY2022</u> <u>Management</u> <u>Plan</u>	<u>FY2023</u> <u>Governor</u>		
Full-time	9	9	Annual Salaries	953,540
Part-time	0	0	COLA	675
Nonpermanent	0	0	Premium Pay	0
			Annual Benefits	536,891
			<i>Less 2.33% Vacancy Factor</i>	<i>(34,706)</i>
			Lump Sum Premium Pay	0
Totals	9	9	Total Personal Services	1,456,400

Position Classification Summary					
Job Class Title	Anchorage	Fairbanks	Juneau	Others	Total
Associate Attorney 1	1	0	0	0	1
Attorney 3	1	0	0	0	1
Attorney 4	2	0	0	0	2
Attorney 5	1	0	2	0	3
Attorney 6	1	0	0	0	1
Law Office Assistant 2	1	0	0	0	1
Totals	7	0	2	0	9

Component Detail All Funds
Department of Law

Component: Special Litigation (2213)
RDU: Civil Division (Excludes Janus) (35)

Non-Formula Component

	FY2021 Actuals	FY2022 Conference Committee	FY2022 Authorized	FY2022 Management Plan	FY2023 Governor	FY2022 Management Plan vs FY2023 Governor	
71000 Personal Services	0.0	1,497.5	1,497.5	1,489.2	1,456.4	-32.8	-2.2%
72000 Travel	0.0	13.8	13.8	13.8	13.8	0.0	0.0%
73000 Services	4.8	379.9	379.9	379.9	379.9	0.0	0.0%
74000 Commodities	0.0	27.9	27.9	27.9	27.9	0.0	0.0%
75000 Capital Outlay	0.0	0.0	0.0	0.0	0.0	0.0	0.0%
77000 Grants, Benefits	0.0	0.0	0.0	0.0	0.0	0.0	0.0%
78000 Miscellaneous	0.0	0.0	0.0	0.0	0.0	0.0	0.0%
Totals	4.8	1,919.1	1,919.1	1,910.8	1,878.0	-32.8	-1.7%
Fund Sources:							
1004 Gen Fund (UGF)	4.8	1,492.7	1,492.7	1,239.5	1,198.9	-40.6	-3.3%
1007 I/A Rcpts (Other)	0.0	426.4	426.4	671.3	679.1	7.8	1.2%
Unrestricted General (UGF)	4.8	1,492.7	1,492.7	1,239.5	1,198.9	-40.6	-3.3%
Designated General (DGF)	0.0	0.0	0.0	0.0	0.0	0.0	0.0%
Other Funds	0.0	426.4	426.4	671.3	679.1	7.8	1.2%
Federal Funds	0.0	0.0	0.0	0.0	0.0	0.0	0.0%
Positions:							
Permanent Full Time	9	9	9	9	9	0	0.0%
Permanent Part Time	0	0	0	0	0	0	0.0%
Non Permanent	0	0	0	0	0	0	0.0%

Change Record Detail - Multiple Scenarios with Descriptions
Department of Law

Component: Special Litigation (2213)
RDU: Civil Division (Excludes Janus) (35)

Scenario/Change Record Title	Trans Type	Totals	Personal Services	Travel	Services	Commodities	Capital Outlay	Grants, Benefits	Miscellaneous	Positions		NP
										PFT	PPT	
***** Changes From FY2022 Conference Committee To FY2022 Authorized *****												
FY2022 Conference Committee												
	ConfCom	1,919.1	1,497.5	13.8	379.9	27.9	0.0	0.0	0.0	9	0	0
1004 Gen Fund		1,492.7										
1007 I/A Rcpts		426.4										
Subtotal		1,919.1	1,497.5	13.8	379.9	27.9	0.0	0.0	0.0	9	0	0
***** Changes From FY2022 Authorized To FY2022 Management Plan *****												
Transfer Two Attorney Positions from Commercial and Fair Business for Required Legal Expertise												
	Trin	308.2	308.2	0.0	0.0	0.0	0.0	0.0	0.0	2	0	0
1007 I/A Rcpts		308.2										
Transfer one full-time Attorney 3 position (03-0055), range 22 and one full-time Attorney 4 position (03-0428), range 24, both located in Anchorage, from the Commercial and Fair Business component to the Special Litigation component to keep pace with the required level of legal expertise needed within the office. The remaining staff in Commercial and Fair Business are sufficient to accommodate anticipated workload.												
Transfer Attorney 4 (03-0026) to Natural Resources for Required Legal Expertise												
	Trout	-170.1	-170.1	0.0	0.0	0.0	0.0	0.0	0.0	-1	0	0
1004 Gen Fund		-136.1										
1007 I/A Rcpts		-34.0										
Transfer one full-time Attorney 4 position (03-0026), range 24, located in Anchorage, to the Natural Resources component from the Special Litigation component to keep pace with the required level of legal expertise needed within the office. The remaining staff in Special Litigation are sufficient to accommodate anticipated workload.												
Transfer Attorney 4 (03-0410) to Legislation/Regulations for Required Legal Expertise												
	Trout	-146.4	-146.4	0.0	0.0	0.0	0.0	0.0	0.0	-1	0	0
1004 Gen Fund		-117.1										
1007 I/A Rcpts		-29.3										
Transfer one full-time Attorney 4 position (03-0410), range 24, located in Anchorage, to the Legislation/Regulations component from the Special Litigation component to keep pace with the required level of legal expertise needed within the office. The remaining staff in Special Litigation are sufficient to accommodate anticipated workload.												
Transfer Law Office Assistant 2 (03-0208) from Opinions, Appeals and Ethics to Address Workload Demands												
	Trin	0.0	0.0	0.0	0.0	0.0	0.0	0.0	0.0	1	0	0
Transfer a full-time Law Office Assistant 2 (03-0208), range 13, located in Anchorage, from the Opinions, Appeals and Ethics component to the Special Litigation component to accommodate workload demands. The remaining staff in the Opinions, Appeals and Ethics are sufficient to cover the anticipated workload.												
Transfer Law Office Assistant 1 (03-0270) to Opinions, Appeals and Ethics to Address Workload Demands												

Change Record Detail - Multiple Scenarios with Descriptions
Department of Law

Component: Special Litigation (2213)
RDU: Civil Division (Excludes Janus) (35)

Scenario/Change Record Title	Trans Type	Totals	Personal Services	Travel	Services	Commodities	Capital Outlay	Grants, Benefits	Miscellaneous	Positions		
										PFT	PPT	NP
Trout		0.0	0.0	0.0	0.0	0.0	0.0	0.0	0.0	-1	0	0
Transfer a full-time Law Office Assistant 1 (03-0270), range 11, located in Anchorage, to the Opinions, Appeals and Ethics component from the Special Litigation component to accommodate workload demands. The remaining staff in the Special Litigation are sufficient to cover the anticipated workload.												
Subtotal		1,910.8	1,489.2	13.8	379.9	27.9	0.0	0.0	0.0	9	0	0
***** Changes From FY2022 Management Plan To FY2023 Governor *****												
FY2023 Salary and Benefit Adjustments												
SalAdj		0.7	0.7	0.0	0.0	0.0	0.0	0.0	0.0	0	0	0
1004 Gen Fund		0.4										
1007 I/A Rcpts		0.3										
FY2023 SU BU - Supervisory Employees (SS) 1% COLA: \$0.7												
FY2023 Executive Health Insurance, SBS, and Risk Management Rate Changes												
SalAdj		15.4	15.4	0.0	0.0	0.0	0.0	0.0	0.0	0	0	0
1004 Gen Fund		8.7										
1007 I/A Rcpts		6.7										
FY2023 Change Partially Exempt & Exempt Executive (EE) - Health Insurance from \$1,555 to \$1,685; SBS and Risk Management Rates: \$15.4												
FY2023 Supervisory Employees Health Insurance, SBS, and Risk Management Rate Changes												
SalAdj		1.7	1.7	0.0	0.0	0.0	0.0	0.0	0.0	0	0	0
1004 Gen Fund		0.9										
1007 I/A Rcpts		0.8										
FY2023 Change Supervisory Employees (SS) - Health Insurance from \$1,555 to \$1,685; SBS and Risk Management Rates: \$1.7												
FY2023 PERS Actuarial Rate Adjustment to 24.79% Ch9 SLA2021 (SB55)												
SalAdj		-50.6	-50.6	0.0	0.0	0.0	0.0	0.0	0.0	0	0	0
1004 Gen Fund		-30.1										
1007 I/A Rcpts		-20.5										
Includes: FY2023 Adjustment for PERS ARM Board Approved Rate of 24.79% (from 30.11%): \$-50.6												
Realign PERS Rate Adjustment by Fund Source Ch9 SLA2021 (SB55)												
FndChg		0.0	0.0	0.0	0.0	0.0	0.0	0.0	0.0	0	0	0
1004 Gen Fund		-20.5										
1007 I/A Rcpts		20.5										
Remove one-time UGF subsidy for rate agency assigned in SB55 fiscal note (Ch 9 SLA 2021).												

Change Record Detail - Multiple Scenarios with Descriptions
Department of Law

Component: Special Litigation (2213)
RDU: Civil Division (Excludes Janus) (35)

Scenario/Change Record Title	Trans Type	Totals	Personal Services	Travel	Services	Commodities	Capital Outlay	Grants, Benefits	Miscellaneous	Positions		
										PFT	PPT	NP
	Totals	1,878.0	1,456.4	13.8	379.9	27.9	0.0	0.0	0.0	9	0	0

Line Item Detail (1676)
Department of Law
Travel

Component: Special Litigation (2213)

Line Number	Line Name		FY2021 Actuals	FY2022 Management Plan	FY2023 Governor
2000	Travel		0.0	13.8	13.8
Object Class	Servicing Agency	Explanation	FY2021 Actuals	FY2022 Management Plan	FY2023 Governor
2000 Travel Detail Totals			0.0	13.8	13.8
2006	Other Travel Costs	Travel cost transfers.	0.0	13.8	13.8

Line Item Detail (1676)
Department of Law
Services

Component: Special Litigation (2213)

Line Number	Line Name		FY2021 Actuals	FY2022 Management Plan	FY2023 Governor
3000	Services		4.8	379.9	379.9
Object Class	Servicing Agency	Explanation	FY2021 Actuals	FY2022 Management Plan	FY2023 Governor
3000 Services Detail Totals			4.8	379.9	379.9
3000	Education Services	Conferences, training and memberships.	3.2	3.5	3.5
3002	Legal and Judicial Services	Depositions, research costs, expert witness and consultant fees.	1.6	0.0	9.5
3011	Other Services	Cost transfers and miscellaneous items within the services line (commissions, etc.).	0.0	376.4	366.9

Line Item Detail (1676)
Department of Law
Commodities

Component: Special Litigation (2213)

Line Number	Line Name		FY2021 Actuals	FY2022 Management Plan	FY2023 Governor
4000	Commodities		0.0	27.9	27.9
Object Class	Servicing Agency	Explanation	FY2021 Actuals	FY2022 Management Plan	FY2023 Governor
4000 Commodities Detail Totals			0.0	27.9	27.9
4022	Commodity Transfer	Commodity cost transfers.	0.0	27.9	27.9

Revenue Detail (1681)
Department of Law

Component: Special Litigation (2213)

Revenue Type (OMB Fund Code) Revenue Source	Component	Comment	FY2021 Actuals	FY2022 Management Plan	FY2023 Governor
5007 I/A Rcpts (1007 I/A Rcpts)			0.0	671.3	679.1
5301 Inter-Agency Receipts	Law - Dep. Attny General's Office (2205)	Special Litigation provides experienced, specialized legal services and representation to state government for litigation of a complex, specific, and/or large-scale nature. The casework is not necessarily predictable or consistent, so individual agency service costs vary from year to year depending on the volume and length of cases.	0.0	671.3	679.1

Personal Services Expenditure Detail
Department of Law

Scenario: FY2023 Governor (18673)
Component: Special Litigation (2213)
RDU: Civil Division (Excludes Janus) (35)

PCN	Job Class Title	Time Status	Retire Code	Barg Unit	Location	Salary Sched	Range / Step	Comp Months	Split / Count	Annual Salaries	COLA	Premium Pay	Annual Benefits	Total Costs	UGF Amount
03-0042	Attorney 6	FT	A	XE	Anchorage	N00	26Q	12.0		153,075	0	0	76,836	229,911	183,929
03-0055	Attorney 3	FT	A	XE	Anchorage	N00	22C / D	12.0		86,525	0	0	52,451	138,976	0
03-0141	Attorney 5	FT	A	XE	Juneau	N05	25J	12.0		124,040	0	0	66,417	190,457	190,457
03-0208	Law Office Assistant 2	FT	A	SS	Anchorage	600	13B / C	12.0		49,168	675	0	38,687	88,530	44,265
03-0231	Associate Attorney 1	FT	A	XE	Anchorage	N00	17A / B	12.0		57,701	0	0	41,719	99,420	49,710
03-0267	Attorney 4	FT	A	XE	Anchorage	N00	24F / J	12.0		106,882	0	0	60,029	166,911	83,456
03-0345	Attorney 5	FT	A	XE	Juneau	N05	25O	12.0		145,568	0	0	74,432	220,000	176,000
03-0422	Attorney 5	FT	A	XE	Anchorage	N00	25K	12.0		121,973	0	0	65,648	187,621	150,097
03-0428	Attorney 4	FT	A	XE	Anchorage	N00	24F / J	12.0		108,608	0	0	60,672	169,280	0
													Total Salary Costs:	953,540	
													Total COLA:	675	
													Total Premium Pay:	0	
													Total Benefits:	536,891	
													Total Pre-Vacancy:	1,491,106	
													Minus Vacancy Adjustment of 2.33%:	(34,706)	
													Total Post-Vacancy:	1,456,400	
													Plus Lump Sum Premium Pay:	0	
													Personal Services Line 100:	1,456,400	
		Total Component Months:	108.0												

PCN Funding Sources:	Pre-Vacancy	Post-Vacancy	Percent
1004 General Fund Receipts	877,913	857,479	58.88%
1007 Interagency Receipts	613,193	598,921	41.12%
Total PCN Funding:	1,491,106	1,456,400	100.00%

Note: If a position is split, an asterisk (*) will appear in the Split/Count column. If the split position is also counted in the component, two asterisks (**) will appear in this column. [No valid job title] appearing in the Job Class Title indicates that the PCN has an invalid class code or invalid range for the class code effective date of this scenario.

CIVIL DIVISION

Special Litigation

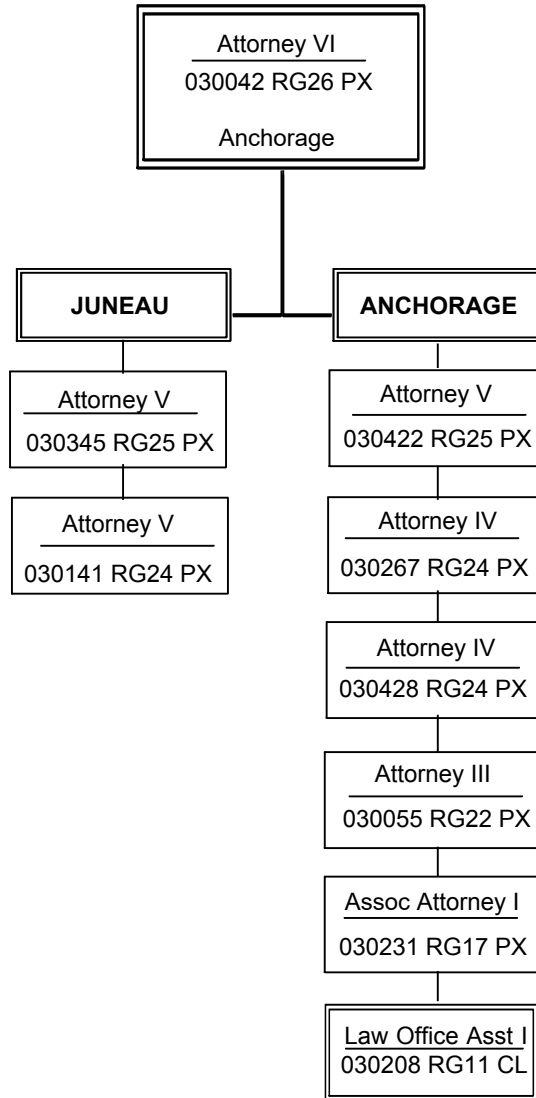

State of Alaska FY2023 Governor's Operating Budget

Department of Law Information and Project Support Component Budget Summary

Component: Information and Project Support

Contribution to Department's Mission

The Information and Project Support Section focuses on the retention, management, review, and disclosure of information in litigation, in responding to Alaska Public Records Act (APRA) requests, in conducting law enforcement and personnel investigations, and to comply with the State Records Management Act. The section recommends, customizes, and operates systems for the department's management, review, and disclosure of information (e.g., the department's electronic discovery (e-Discovery) and legal hold tools and the Civil Division's matter-management, accounting, timekeeping, and reporting system). The section also trains department personnel on using those systems, designs and maintains the department's Internet and intranet websites, and designs the department's publications, including reports and presentations.

Core Services

- Advising and representing agencies, including the Department of Law, in (1) matters concerning the retention, management, review, and disclosure of information in electronic or non-electronic form and (2) the use of technology for such purposes.
- Operating and training personnel on the department's e-Discovery and legal hold tools.
- Developing, operating, and training personnel on the Civil Division's matter-management system, including customizing applications for tracking records and reporting purposes.
- Designing and maintaining the department's Internet and intranet websites and publications.

Major Component Accomplishments in 2021

- Transparency and Records Retention: Responded to and advised and trained agencies on responding to APRA requests; advised agencies on the Open Meetings Act; and advised agencies on records retention issues.
- Protected Information: Advised and trained agencies on identifying and protecting privileged and confidential information.
- Electronic Discovery and Legal Holds: Assisted with e-Discovery and the implementation of legal holds; and operated and trained department employees on the department's e-Discovery and legal hold tools.
- Matter-management: Operated and trained division employees on the Civil Division's matter-management system.
- Internet, Intranet and Publications: Upgraded and maintained the department's Internet and intranet webpages; designed and updated department publications.

Key Component Challenges

The section's key challenges include continuing (1) to respond to and to advise and train agencies on responding to APRA requests, (2) to advise and train agencies on protecting privileged and confidential information, (3) to make e-Discovery and legal hold tools available and to assist with e-Discovery and the implementation of legal holds, (4) to operate and train employees on the division's matter-management system, and (5) to advise agencies on records retention and Open Meetings Act issues.

Significant Changes in Results to be Delivered in FY2023

No significant changes are anticipated in the next fiscal year.

Statutory and Regulatory Authority

AS 44.23.020

Contact Information
<p>Contact: Alan Birnbaum, Chief Assistant Attorney General Phone: (907) 269-5100 E-mail: alan.birnbaum@alaska.gov</p>

Information and Project Support Personal Services Information				
Authorized Positions			Personal Services Costs	
	<u>FY2022</u> <u>Management</u> <u>Plan</u>	<u>FY2023</u> <u>Governor</u>		
Full-time	18	18	Annual Salaries	1,283,052
Part-time	0	0	COLA	4,240
Nonpermanent	0	0	Premium Pay	0
			Annual Benefits	827,269
			<i>Less 3.07% Vacancy Factor</i>	(64,861)
			Lump Sum Premium Pay	0
Totals	18	18	Total Personal Services	2,049,700

Position Classification Summary					
Job Class Title	Anchorage	Fairbanks	Juneau	Others	Total
Administrative Assistant 2	1	1	0	0	2
Administrative Assistant 3	1	0	0	0	1
Admn OPS Mgr 1	1	0	0	0	1
Associate Attorney 1	0	0	1	0	1
Associate Attorney 2	1	0	0	0	1
Attorney 4	1	0	0	0	1
Attorney 6	1	0	0	0	1
Internet Specialist 2	1	0	0	0	1
Law Office Assistant 1	3	0	1	0	4
Law Office Manager 1	1	0	0	0	1
Law Office Manager 2	1	0	0	0	1
Paralegal 2	3	0	0	0	3
Totals	15	1	2	0	18

Component Detail All Funds
Department of Law

Component: Information and Project Support (2258)
RDU: Civil Division (Excludes Janus) (35)

Non-Formula Component

	FY2021 Actuals	FY2022 Conference Committee	FY2022 Authorized	FY2022 Management Plan	FY2023 Governor	FY2022 Management Plan vs FY2023 Governor	
71000 Personal Services	1,680.5	1,804.8	1,804.8	2,048.8	2,049.7	0.9	0.0%
72000 Travel	2.2	5.3	5.3	5.3	5.3	0.0	0.0%
73000 Services	411.0	154.1	154.1	154.1	104.1	-50.0	-32.4%
74000 Commodities	11.9	6.6	6.6	6.6	6.6	0.0	0.0%
75000 Capital Outlay	4.0	0.0	0.0	0.0	0.0	0.0	0.0%
77000 Grants, Benefits	0.0	0.0	0.0	0.0	0.0	0.0	0.0%
78000 Miscellaneous	0.0	0.0	0.0	0.0	0.0	0.0	0.0%
Totals	2,109.6	1,970.8	1,970.8	2,214.8	2,165.7	-49.1	-2.2%
Fund Sources:							
1004 Gen Fund (UGF)	47.1	519.4	519.4	519.4	457.6	-61.8	-11.9%
1007 I/A Rcpts (Other)	2,062.5	1,451.4	1,451.4	1,695.4	1,708.1	12.7	0.7%
Unrestricted General (UGF)	47.1	519.4	519.4	519.4	457.6	-61.8	-11.9%
Designated General (DGF)	0.0	0.0	0.0	0.0	0.0	0.0	0.0%
Other Funds	2,062.5	1,451.4	1,451.4	1,695.4	1,708.1	12.7	0.7%
Federal Funds	0.0	0.0	0.0	0.0	0.0	0.0	0.0%
Positions:							
Permanent Full Time	17	16	16	18	18	0	0.0%
Permanent Part Time	0	0	0	0	0	0	0.0%
Non Permanent	0	0	0	0	0	0	0.0%

Change Record Detail - Multiple Scenarios with Descriptions
Department of Law

Component: Information and Project Support (2258)
RDU: Civil Division (Excludes Janus) (35)

Scenario/Change Record Title	Trans Type	Totals	Personal Services	Travel	Services	Commodities	Capital Outlay	Grants, Benefits	Miscellaneous	Positions		NP
										PFT	PPT	
***** Changes From FY2022 Conference Committee To FY2022 Authorized *****												
FY2022 Conference Committee												
	ConfCom	1,970.8	1,804.8	5.3	154.1	6.6	0.0	0.0	0.0	16	0	0
1004 Gen Fund		519.4										
1007 I/A Rcpts		1,451.4										
Subtotal		1,970.8	1,804.8	5.3	154.1	6.6	0.0	0.0	0.0	16	0	0
***** Changes From FY2022 Authorized To FY2022 Management Plan *****												
Transfer Two Support Positions from Torts and Workers' Compensation to Address Workload Demands												
	Trin	73.9	73.9	0.0	0.0	0.0	0.0	0.0	0.0	2	0	0
1007 I/A Rcpts		73.9										
Transfer a full-time Associate Attorney 2 (03-0143), range 19, and a full-time Law Office Assistant 1 (03-0347), range 11, both located in Anchorage, from the Torts and Workers' Compensation component to the Information and Project Support component to accommodate workload demands. The remaining staff in Torts and Workers' Compensation are sufficient to cover the anticipated workload.												
Transfer Associate Attorney 2 (03-0321) from Torts and Workers' Compensation to Address Workload Demands												
	Trout	0.0	0.0	0.0	0.0	0.0	0.0	0.0	0.0	-1	0	0
Transfer a full-time Associate Attorney 2 (03-0321), range 19, located in Anchorage, to the Torts and Workers' Compensation component from the Information and Project Support component to accommodate workload demands. The remaining staff in Information and Project Support are sufficient to cover the anticipated workload.												
Transfer Attorney 4 (03-0082) from Commercial and Fair Business for Required Legal Expertise												
	Trin	170.1	170.1	0.0	0.0	0.0	0.0	0.0	0.0	1	0	0
1007 I/A Rcpts		170.1										
Transfer one full-time Attorney 4 position (03-0082), range 24, located in Anchorage, from the Commercial and Fair Business component to the Information and Project Support component to keep pace with the required level of legal expertise needed within the office. The remaining staff in Commercial and Fair Business are sufficient to accommodate anticipated workload.												
Subtotal		2,214.8	2,048.8	5.3	154.1	6.6	0.0	0.0	0.0	18	0	0
***** Changes From FY2022 Management Plan To FY2023 Governor *****												
FY2023 Salary and Benefit Adjustments												
	SalAdj	0.9	0.9	0.0	0.0	0.0	0.0	0.0	0.0	0	0	0
1004 Gen Fund		0.9										
FY2023 SU BU - Supervisory Employees (SS) 1% COLA: \$0.9												

Change Record Detail - Multiple Scenarios with Descriptions
Department of Law

Component: Information and Project Support (2258)
RDU: Civil Division (Excludes Janus) (35)

Scenario/Change Record Title	Trans Type	Totals	Personal Services	Travel	Services	Commodities	Capital Outlay	Grants, Benefits	Miscellaneous	Positions		NP
										PFT	PPT	
FY2023 Executive Health Insurance, SBS, and Risk Management Rate Changes												
	SalAdj	7.4	7.4	0.0	0.0	0.0	0.0	0.0	0.0	0	0	0
1004 Gen Fund		0.8										
1007 I/A Rcpts		6.6										
FY2023 Change Partially Exempt & Exempt Executive (EE) - Health Insurance from \$1,555 to \$1,685; SBS and Risk Management Rates: \$7.4												
FY2023 Supervisory Employees Health Insurance, SBS, and Risk Management Rate Changes												
	SalAdj	6.8	6.8	0.0	0.0	0.0	0.0	0.0	0.0	0	0	0
1004 Gen Fund		1.9										
1007 I/A Rcpts		4.9										
FY2023 Change Supervisory Employees (SS) - Health Insurance from \$1,555 to \$1,685; SBS and Risk Management Rates: \$6.8												
FY2023 General Government Unit SBS and Risk Management Rate Changes												
	SalAdj	1.5	1.5	0.0	0.0	0.0	0.0	0.0	0.0	0	0	0
1004 Gen Fund		0.3										
1007 I/A Rcpts		1.2										
FY2023 Change General Government Unit (GG, GP, GY, GZ) - SBS, and Risk Management Rates: \$1.5												
FY2023 PERS Actuarial Rate Adjustment to 24.79% Ch9 SLA2021 (SB55)												
	SalAdj	-65.7	-65.7	0.0	0.0	0.0	0.0	0.0	0.0	0	0	0
1004 Gen Fund		-13.1										
1007 I/A Rcpts		-52.6										
Includes: FY2023 Adjustment for PERS ARM Board Approved Rate of 24.79% (from 30.11%): \$-65.7												
Realign PERS Rate Adjustment by Fund Source Ch9 SLA2021 (SB55)												
	FndChg	0.0	0.0	0.0	0.0	0.0	0.0	0.0	0.0	0	0	0
1004 Gen Fund		-52.6										
1007 I/A Rcpts		52.6										
Remove one-time UGF subsidy for rate agency assigned in SB55 fiscal note (Ch 9 SLA 2021).												
Transfer Authority to Personal Services for Anticipated Expenditures												
	LIT	0.0	50.0	0.0	-50.0	0.0	0.0	0.0	0.0	0	0	0
Transfer authority to the personal services line from the services line for anticipated costs. The remaining services authority is anticipated to be sufficient to cover operating expenditures.												

Change Record Detail - Multiple Scenarios with Descriptions
Department of Law

Component: Information and Project Support (2258)

RDU: Civil Division (Excludes Janus) (35)

Scenario/Change Record Title	Trans Type	Totals	Personal Services	Travel	Services	Commodities	Capital Outlay	Grants, Benefits	Miscellaneous	Positions		
										PFT	PPT	NP
	Totals	2,165.7	2,049.7	5.3	104.1	6.6	0.0	0.0	0.0	18	0	0

Line Item Detail (1676)
Department of Law
Travel

Component: Information and Project Support (2258)

Line Number	Line Name		FY2021 Actuals	FY2022 Management Plan	FY2023 Governor
2000	Travel		2.2	5.3	5.3
Object Class	Servicing Agency	Explanation	FY2021 Actuals	FY2022 Management Plan	FY2023 Governor
2000 Travel Detail Totals			2.2	5.3	5.3
2000	In-State Employee Travel	Travel for attorneys to interview witnesses and attend court proceedings, as well as for necessary training for both attorneys and paraprofessionals. Includes travel for management purposes.	0.0	3.3	3.3
2006	Other Travel Costs	Travel cost transfers.	2.2	2.0	2.0

Line Item Detail (1676)
Department of Law
Services

Component: Information and Project Support (2258)

Line Number	Line Name			FY2021 Actuals	FY2022 Management Plan	FY2023 Governor
3000	Services			411.0	154.1	104.1
Object Class	Servicing Agency	Explanation		FY2021 Actuals	FY2022 Management Plan	FY2023 Governor
3000 Services Detail Totals				411.0	154.1	104.1
3000	Education Services	Conferences, training and memberships.		0.7	0.7	0.7
3003	Information Technology	Training, consulting and software licensing and maintenance. Annual maintenance fee for mission-critical information management systems.		69.8	1.7	1.7
3004	Telecommunications	Local telephone service, long distance charges and cellular phone services paid to third-party telephone utilities.		38.0	2.5	2.5
3011	Other Services	Cost transfers and miscellaneous items within the services line (commissions, etc.).		161.5	8.2	0.0
3013	Inter-Agency Data Processing Operations Allocation	Law - Administrative Services (2164)	RSA Law, Information services, data processing investments and support.	2.6	2.6	0.0
3017	Inter-Agency Information Technology Non-Telecommunications	Admin - Department-wide	RSA Administration, Office of Information Technology computer services.	27.9	27.9	7.9
3018	Inter-Agency Information Technology Telecommunications	Admin - Department-wide	RSA Administration, Office of Information Technology telecommunications services.	3.6	3.6	3.6
3021	Inter-Agency Mail	Admin - Department-wide	RSA Administration, Central Mail.	0.3	0.3	0.3
3022	Inter-Agency Human Resources	Law - Administrative Services (2164)	RSA Law, Human Resources position.	6.3	6.3	6.3
3023	Inter-Agency Building Leases	Admin - Department-wide	Leased office space managed by General Services.	99.2	99.2	80.0

Line Item Detail (1676)
Department of Law
Services

Component: Information and Project Support (2258)

Object Class		Servicing Agency	Explanation	FY2021 Actuals	FY2022 Management Plan	FY2023 Governor
3000 Services Detail Totals				411.0	154.1	104.1
3026	Inter-Agency Insurance	Admin - Department-wide	RSA Administration, Risk Management.	0.5	0.5	0.5
3027	Inter-Agency Financial	Admin - Department-wide	RSA Administration, Finance Chargeback (IRIS).	0.5	0.5	0.5
3028	Inter-Agency Americans with Disabilities Act Compliance		RSA Administration - Division of Personnel and Labor Relations, Americans with Disabilities Act.	0.1	0.1	0.1

Line Item Detail (1676)
Department of Law
Commodities

Component: Information and Project Support (2258)

Line Number	Line Name		FY2021 Actuals	FY2022 Management Plan	FY2023 Governor
4000	Commodities		11.9	6.6	6.6
Object Class	Servicing Agency	Explanation	FY2021 Actuals	FY2022 Management Plan	FY2023 Governor
4000 Commodities Detail Totals			11.9	6.6	6.6
4000	Business	Reference materials and subscriptions, including statutes, software applications, non-capital desktop refresh, and miscellaneous office supplies.	0.4	0.4	0.4
4022	Commodity Transfer	Commodity cost transfers.	11.5	6.2	6.2

Line Item Detail (1676)
Department of Law
Capital Outlay

Component: Information and Project Support (2258)

Line Number	Line Name		FY2021 Actuals	FY2022 Management Plan	FY2023 Governor
5000	Capital Outlay		4.0	0.0	0.0
Object Class	Servicing Agency	Explanation	FY2021 Actuals	FY2022 Management Plan	FY2023 Governor
5000 Capital Outlay Detail Totals			4.0	0.0	0.0
5009	Capital Outlay Transfer	Capital cost transfers.	4.0	0.0	0.0

Revenue Detail (1681)
Department of Law

Component: Information and Project Support (2258)

Revenue Type (OMB Fund Code) Revenue Source	Component	Comment	FY2021 Actuals	FY2022 Management Plan	FY2023 Governor
5007 I/A Rcpts (1007 I/A Rcpts)			2,062.5	1,695.4	1,708.1
5301 Inter-Agency Receipts	Law - Dep. Attny General's Office (2205)	RSA Law, Deputy Attorney General's Office - timekeeping and project support across the Civil Division. Program code: CV03213590.	2,062.5	1,695.4	1,708.1

Inter-Agency Services (1682)
Department of Law

Component: Information and Project Support (2258)

				FY2021 Actuals	FY2022 Management Plan	FY2023 Governor
Component Totals				140.9	140.9	99.1
With Department of Law				8.9	8.9	6.3
With Department of Administration				132.0	132.0	92.8
Object Class	Servicing Agency	Explanation	FY2021 Actuals	FY2022 Management Plan	FY2023 Governor	
3013	Inter-Agency Data Processing Operations Allocation	Law - Administrative Services (2164)	RSA Law, Information services, data processing investments and support.	2.6	2.6	0.0
3017	Inter-Agency Information Technology Non-Telecommunications	Admin - Department-wide	RSA Administration, Office of Information Technology computer services.	27.9	27.9	7.9
3018	Inter-Agency Information Technology Telecommunications	Admin - Department-wide	RSA Administration, Office of Information Technology telecommunications services.	3.6	3.6	3.6
3021	Inter-Agency Mail	Admin - Department-wide	RSA Administration, Central Mail.	0.3	0.3	0.3
3022	Inter-Agency Human Resources	Law - Administrative Services (2164)	RSA Law, Human Resources position.	6.3	6.3	6.3
3023	Inter-Agency Building Leases	Admin - Department-wide	Leased office space managed by General Services.	99.2	99.2	80.0
3026	Inter-Agency Insurance	Admin - Department-wide	RSA Administration, Risk Management.	0.5	0.5	0.5
3027	Inter-Agency Financial	Admin - Department-wide	RSA Administration, Finance Chargeback (IRIS).	0.5	0.5	0.5

Personal Services Expenditure Detail
Department of Law

Scenario: FY2023 Governor (18673)
Component: Information and Project Support (2258)
RDU: Civil Division (Excludes Janus) (35)

PCN	Job Class Title	Time Status	Retire Code	Barg Unit	Location	Salary Sched	Range / Step	Comp Months	Split / Count	Annual Salaries	COLA	Premium Pay	Annual Benefits	Total Costs	UGF Amount
03-0016	Internet Specialist 2	FT	A	GP	Anchorage	200	19M	12.0		90,344	0	0	52,416	142,760	0
03-0021	Law Office Assistant 1	FT	A	GP	Anchorage	200	11B / C	12.0		39,676	0	0	33,553	73,229	0
03-0022	Law Office Manager 1	FT	A	SS	Anchorage	200	15J / K	12.0		66,846	917	0	45,268	113,031	0
03-0032	Administrative Assistant 3	FT	A	SS	Anchorage	600	15M / N	12.0		72,437	994	0	47,350	120,781	120,781
03-0052	Administrative Assistant 2	FT	A	GP	Fairbanks	203	14A / B	12.0		47,830	0	0	36,588	84,418	0
03-0082	Attorney 4	FT	A	XE	Anchorage	N00	24C / D	12.0		97,861	0	0	56,671	154,532	0
03-0138	Paralegal 2	FT	A	GP	Anchorage	200	16J	12.0		67,197	0	0	43,799	110,996	11,100
03-0143	Associate Attorney 2	FT	A	XE	Anchorage	N00	19K / L	12.0		82,863	0	0	51,087	133,950	0
03-0145	Law Office Assistant 1	FT	A	GP	Anchorage	200	11D / E	12.0		41,789	0	0	34,339	76,128	0
03-0149	Law Office Manager 2	FT	A	SS	Anchorage	200	16F	12.0		68,078	934	0	45,727	114,739	0
03-0185	Paralegal 2	FT	A	GP	Anchorage	200	16B / C	12.0		54,321	0	0	39,005	93,326	93,326
03-0273	Paralegal 2	FT	A	GP	Anchorage	200	16M	12.0		73,964	0	0	46,318	120,282	0
03-0277	Law Office Assistant 1	FT	A	GP	Juneau	205	11E / F	12.0		46,003	0	0	35,908	81,911	0
03-0333	Admn OPS Mgr 1	FT	A	SS	Anchorage	200	22F	12.0		101,650	1,395	0	58,226	161,271	16,127
03-0347	Law Office Assistant 1	FT	A	GP	Anchorage	200	11B / C	12.0		39,865	0	0	33,623	73,488	0
03-0398	Attorney 6	FT	A	XE	Anchorage	99	26Q / R	12.0		158,096	0	0	78,398	236,494	35,474
03-1214	Administrative Assistant 2	FT	A	GP	Anchorage	200	14K / L	12.0		60,561	0	0	41,328	101,889	101,889
03-1246	Associate Attorney 1	FT	A	XE	Juneau	N05	17J / K	12.0		73,671	0	0	47,665	121,336	0

Total Positions		New	Deleted	Total Salary Costs:	1,283,052
Full Time Positions:	18	0	0	Total COLA:	4,240
Part Time Positions:	0	0	0	Total Premium Pay:	0
Non Permanent Positions:	0	0	0	Total Benefits:	827,269
Positions in Component:	18	0	0	Total Pre-Vacancy:	2,114,561
				Minus Vacancy Adjustment of 3.07%:	(64,861)
				Total Post-Vacancy:	2,049,700
Total Component Months:	216.0			Plus Lump Sum Premium Pay:	0
				Personal Services Line 100:	2,049,700

PCN Funding Sources:	Pre-Vacancy	Post-Vacancy	Percent
1004 General Fund Receipts	378,697	367,081	17.91%
1007 Interagency Receipts	1,735,864	1,682,619	82.09%
Total PCN Funding:	2,114,561	2,049,700	100.00%

Note: If a position is split, an asterisk (*) will appear in the Split/Count column. If the split position is also counted in the component, two asterisks (**) will appear in this column. [No valid job title] appearing in the Job Class Title indicates that the PCN has an invalid class code or invalid range for the class code effective date of this scenario.

CIVIL DIVISION

Information and Project Support

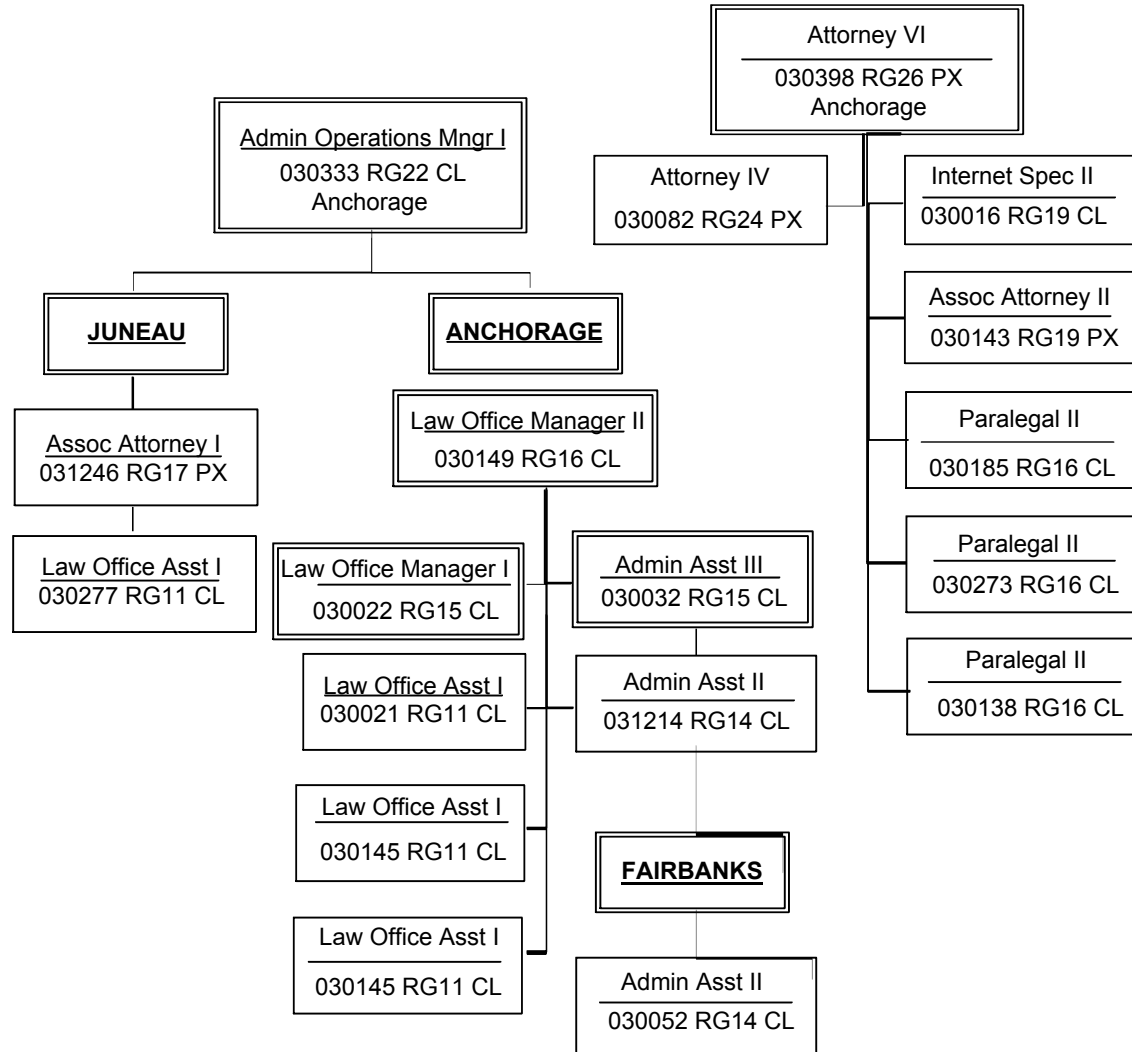

State of Alaska
FY2023 Governor's Operating Budget

Department of Law
Torts & Workers' Compensation
Component Budget Summary

Component: Torts & Workers' Compensation

Contribution to Department's Mission

The Torts and Workers' Compensation Section provides legal defense and advice in a wide range of tort lawsuits filed against state agencies and state employees, including personal injury, wrongful death, professional malpractice, property damage, and civil rights claims. It also provides advice and training to state agencies and represents the state as an employer before the Alaska Workers' Compensation Board (AWCB) and the Alaska Workers' Compensation Appeals Commission.

Core Services

- Attorneys in the Torts and Workers' Compensation section defend tort claims and civil rights claims for damages under 42 USC §1983 filed in state and federal trial and appellate courts.
- Attorneys in the section represent state agencies in workers' compensation claims filed by state employees where the State of Alaska is the employer. They advocate on behalf of the state at hearings before the AWCB and represent the state as the employer in appeals from board decisions taken to the Alaska Workers' Compensation Appeals Commission and to the Alaska Supreme Court.
- Attorneys in the section advise the Department of Corrections on legal matters and represent it in inmate post-conviction relief petitions and administrative disciplinary appeals in state court and inmate civil rights claims under 42 USC §1983 filed in state and federal trial and appellate courts.
- Attorneys in the section provide advice and training to state agencies on risk management, workers' compensation, and liability issues and provide advice to state adjusters on workers' compensation issues.

Major Component Accomplishments in 2021

On behalf of the self-insured Division of Risk Management in the Department of Administration, the section pursues aggressive motion practice, trial, or negotiation to contain the ultimate costs of tort cases filed against the State of Alaska and its employees and in workers' compensation matters involving state employees. The section represented the state and/or its employees in 107 tort cases and 192 workers' compensation cases. The section also pursues aggressive motion practice, trial or negotiation to contain costs associated with civil and administrative litigation filed by inmates against the Department of Corrections and its employees. The section represented DOC and/or its employees in 256 civil and administrative matters.

- Investigated and referred a workers' compensation case to the AWCB's fraud investigation unit, leading to a jury conviction of a former employee for defrauding the state out of more than \$250,000 in workers' compensation benefits and a two-year jail sentence. The fraud petition filed by the section with the AWCB is stayed pending appeal of the criminal felony fraud conviction and sentence.
- Defended the state as an employer in numerous hearings before the AWCB and in appeals before the Alaska Workers' Compensation Appeals Commission and the Alaska Supreme Court.
- Won an appeal in the Alaska Supreme Court reversing the trial court's order directing the release of DOC investigatory records because the records are shielded from disclosure by the invasion of privacy exemption to the Alaska Public Records Act.
- After years of briefing and remand from the Alaska Supreme Court, won dismissal of the third party allocation of fault claim against the state for alleged sexual assault of a minor. This case is on appeal for the third time to the Alaska Supreme Court.
- Won an appeal in the Ninth Circuit Court of Appeals affirming dismissal of a wrongful death lawsuit filed against the state on the grounds the Alaska State Troopers' conduct was entitled to qualified immunity.
- Won an appeal in the Alaska Supreme Court affirming summary judgment and dismissal of an inmate's medical malpractice lawsuit against the state and its mental health providers.

- Won an appeal to the Alaska Supreme Court affirming dismissal of an inmate's civil rights lawsuit against the state on the grounds the state appropriately restricted the inmate's visitation rights due to prison security concerns.
- Won summary judgment and dismissal of a wrongful death lawsuit against the state based upon the licensing and monitoring of an assisted living center.
- Won summary judgment and dismissal of several medical malpractice cases.
- The section briefed significant issues about the scope of discovery of confidential child protection, mental health, medical, and other records of third parties not directly involved in litigation, and protection of privacy interests.
- Prevailed on dispositive motions to dismiss or for summary judgment in a number of other cases, and obtained attorney fee awards as prevailing party. In addition, motions filed by the section assisted in settlement negotiations and in resolving cases on favorable terms. The section also succeeded in obtaining voluntary dismissal of numerous tort and DOC civil lawsuits, where the state paid nothing and each side assumed its own expenses.
- Provided training on civil law and liability to multiple training academies for correctional and probation officers. The section also provided training for the state's independent workers' compensation adjusters.

Key Component Challenges

One key component challenge stems from the Alaska standard for summary judgment. Summary judgment is a useful tool for concluding civil litigation short of trial. However, Alaska law precludes the grant of summary judgment if there are any material issues in dispute. The court may not evaluate the overwhelming weight of the evidence in support of the motion, nor may it make credibility judgments even when the plaintiff's assertions as to material facts are unsubstantiated. The result is that where the court denies summary judgment, the section must consider the substantial cost of taking the case to trial in determining whether a settlement might be a more economical use of state resources.

Another continuing key challenge involves defending lawsuits brought by unrepresented plaintiffs. Because these cases take more time, a disproportionate amount of the section's resources is channeled to defending these lawsuits.

The section continues to deal with a high volume of matters referred for legal assistance from the Third-Party Administrator for the workers' compensation program of the Division of Risk Management. Keeping up with the workers' compensation caseload will likely remain a challenge.

Significant Changes in Results to be Delivered in FY2023

No significant changes are anticipated in the next fiscal year.

Statutory and Regulatory Authority

AS 44.23.020

Contact Information
Contact: Patti Shake, Chief Assistant Attorney General Phone: (907) 269-5100 E-mail: patti.shake@alaska.gov

Torts & Workers' Compensation Personal Services Information				
Authorized Positions			Personal Services Costs	
	<u>FY2022</u> <u>Management</u> <u>Plan</u>	<u>FY2023</u> <u>Governor</u>		
Full-time	33	32	Annual Salaries	2,681,038
Part-time	0	0	COLA	2,066
Nonpermanent	0	0	Premium Pay	0
			Annual Benefits	1,622,987
			<i>Less 0.70% Vacancy Factor</i>	(30,291)
			Lump Sum Premium Pay	0
Totals	33	32	Total Personal Services	4,275,800

Position Classification Summary					
Job Class Title	Anchorage	Fairbanks	Juneau	Others	Total
Associate Attorney 1	1	0	1	0	2
Associate Attorney 2	1	0	0	0	1
Attorney 2	2	0	0	0	2
Attorney 3	2	0	0	0	2
Attorney 4	6	0	1	0	7
Attorney 5	4	1	0	0	5
Attorney 6	1	0	0	0	1
Law Office Assistant 1	3	1	0	0	4
Law Office Assistant 2	2	0	1	0	3
Paralegal 1	1	0	0	0	1
Paralegal 2	3	1	0	0	4
Totals	26	3	3	0	32

Component Detail All Funds
Department of Law

Component: Torts & Workers' Compensation (2719)
RDU: Civil Division (Excludes Janus) (35)

Non-Formula Component

	FY2021 Actuals	FY2022 Conference Committee	FY2022 Authorized	FY2022 Management Plan	FY2023 Governor	FY2022 Management Plan vs FY2023 Governor	
71000 Personal Services	3,123.4	4,449.1	4,449.1	4,375.2	4,275.8	-99.4	-2.3%
72000 Travel	7.2	17.2	17.2	17.2	17.2	0.0	0.0%
73000 Services	621.4	93.7	93.7	93.7	93.7	0.0	0.0%
74000 Commodities	36.1	33.6	33.6	33.6	33.6	0.0	0.0%
75000 Capital Outlay	12.5	0.0	0.0	0.0	0.0	0.0	0.0%
77000 Grants, Benefits	0.0	0.0	0.0	0.0	0.0	0.0	0.0%
78000 Miscellaneous	0.0	0.0	0.0	0.0	0.0	0.0	0.0%
Totals	3,800.6	4,593.6	4,593.6	4,519.7	4,420.3	-99.4	-2.2%
Fund Sources:							
1004 Gen Fund (UGF)	10.6	219.6	219.6	219.6	75.4	-144.2	-65.7%
1007 I/A Rcpts (Other)	3,790.0	4,374.0	4,374.0	4,300.1	4,344.9	44.8	1.0%
Unrestricted General (UGF)	10.6	219.6	219.6	219.6	75.4	-144.2	-65.7%
Designated General (DGF)	0.0	0.0	0.0	0.0	0.0	0.0	0.0%
Other Funds	3,790.0	4,374.0	4,374.0	4,300.1	4,344.9	44.8	1.0%
Federal Funds	0.0	0.0	0.0	0.0	0.0	0.0	0.0%
Positions:							
Permanent Full Time	33	34	34	33	32	-1	-3.0%
Permanent Part Time	0	0	0	0	0	0	0.0%
Non Permanent	0	0	0	0	0	0	0.0%

Change Record Detail - Multiple Scenarios with Descriptions
Department of Law

Component: Torts & Workers' Compensation (2719)
RDU: Civil Division (Excludes Janus) (35)

Scenario/Change Record Title	Trans Type	Totals	Personal Services	Travel	Services	Commodities	Capital Outlay	Grants, Benefits	Miscellaneous	Positions		NP
										PFT	PPT	
***** Changes From FY2022 Conference Committee To FY2022 Authorized *****												
FY2022 Conference Committee												
ConfCom		4,593.6	4,449.1	17.2	93.7	33.6	0.0	0.0	0.0	34	0	0
1004 Gen Fund		219.6										
1007 I/A Rcpts		4,374.0										
Subtotal		4,593.6	4,449.1	17.2	93.7	33.6	0.0	0.0	0.0	34	0	0
***** Changes From FY2022 Authorized To FY2022 Management Plan *****												
Transfer Law Office Assistant 1 (03-0171) from Transportation to Address Workload Demands												
Trin		0.0	0.0	0.0	0.0	0.0	0.0	0.0	0.0	1	0	0
Transfer a full-time Law Office Assistant 1 (03-0171), range 11, located in Fairbanks, from the Transportation component to the Torts and Workers' Compensation component to accommodate workload demands. The remaining staff in Transportation are sufficient to cover the anticipated workload.												
Transfer Two Support Positions to Information and Project Support to Address Workload Demands												
Trout		-73.9	-73.9	0.0	0.0	0.0	0.0	0.0	0.0	-2	0	0
1007 I/A Rcpts		-73.9										
Transfer a full-time Associate Attorney 2 (03-0143), range 19, and a full-time Law Office Assistant 1 (03-0347), range 11, both located in Anchorage, to the Information and Project Support component from the Torts and Workers' Compensation component to accommodate workload demands. The remaining staff in Torts and Workers' Compensation are sufficient to cover the anticipated workload.												
Transfer Associate Attorney 2 (03-0321) from Information and Project Support to Address Workload Demands												
Trin		0.0	0.0	0.0	0.0	0.0	0.0	0.0	0.0	1	0	0
Transfer a full-time Associate Attorney 2 (03-0321), range 19, located in Anchorage, from the Information and Project Support component to the Torts and Workers' Compensation component to accommodate workload demands. The remaining staff in Information and Project Support are sufficient to cover the anticipated workload.												
Transfer Paralegal 1 (03-0397) to Labor and State Affairs to Address Workload Demands												
Trout		0.0	0.0	0.0	0.0	0.0	0.0	0.0	0.0	-1	0	0
Transfer a full-time Paralegal 1 (03-0397), range 14, located in Juneau, from the Torts and Workers' Compensation component to the Labor and State Affairs component accommodate workload demands. The remaining staff in Torts and Workers' Compensation are sufficient to cover the anticipated workload.												
Subtotal		4,519.7	4,375.2	17.2	93.7	33.6	0.0	0.0	0.0	33	0	0
***** Changes From FY2022 Management Plan To FY2023 Governor *****												
FY2023 Salary and Benefit Adjustments												
SalAdj		2.1	2.1	0.0	0.0	0.0	0.0	0.0	0.0	0	0	0

Change Record Detail - Multiple Scenarios with Descriptions
Department of Law

Component: Torts & Workers' Compensation (2719)
RDU: Civil Division (Excludes Janus) (35)

Scenario/Change Record Title	Trans Type	Totals	Personal Services	Travel	Services	Commodities	Capital Outlay	Grants, Benefits	Miscellaneous	Positions		NP
										PFT	PPT	
1004 Gen Fund		0.1										
1007 I/A Rcpts		2.0										
FY2023 SU BU - Supervisory Employees (SS) 1% COLA: \$2.1												
FY2023 Executive Health Insurance, SBS, and Risk Management Rate Changes												
	SalAdj	37.0	37.0	0.0	0.0	0.0	0.0	0.0	0.0	0	0	0
1007 I/A Rcpts		37.0										
FY2023 Change Partially Exempt & Exempt Executive (EE) - Health Insurance from \$1,555 to \$1,685; SBS and Risk Management Rates: \$37.0												
FY2023 Supervisory Employees Health Insurance, SBS, and Risk Management Rate Changes												
	SalAdj	5.0	5.0	0.0	0.0	0.0	0.0	0.0	0.0	0	0	0
1004 Gen Fund		0.3										
1007 I/A Rcpts		4.7										
FY2023 Change Supervisory Employees (SS) - Health Insurance from \$1,555 to \$1,685; SBS and Risk Management Rates: \$5.0												
FY2023 General Government Unit SBS and Risk Management Rate Changes												
	SalAdj	1.2	1.2	0.0	0.0	0.0	0.0	0.0	0.0	0	0	0
1004 Gen Fund		0.1										
1007 I/A Rcpts		1.1										
FY2023 Change General Government Unit (GG, GP, GY, GZ) - SBS, and Risk Management Rates: \$1.2												
FY2023 PERS Actuarial Rate Adjustment to 24.79% Ch9 SLA2021 (SB55)												
	SalAdj	-144.7	-144.7	0.0	0.0	0.0	0.0	0.0	0.0	0	0	0
1004 Gen Fund		-2.4										
1007 I/A Rcpts		-142.3										
Includes: FY2023 Adjustment for PERS ARM Board Approved Rate of 24.79% (from 30.11%): \$-144.7												
Transfer Attorney 4 (03-0142) from Commercial and Fair Business for Required Legal Expertise												
	Trin	0.0	0.0	0.0	0.0	0.0	0.0	0.0	0.0	1	0	0
Transfer one full-time Attorney 4 position (03-0142), range 24, located in Anchorage, to the Torts and Workers' Compensation component from the Commercial and Fair Business component to keep pace with the required level of legal expertise needed within the office. The remaining staff in Commercial and Fair Business are sufficient to accommodate anticipated workload.												
Transfer Attorney 5 (03-0315) to Commercial and Fair Business for Required Legal Expertise												
	Trout	0.0	0.0	0.0	0.0	0.0	0.0	0.0	0.0	-1	0	0

Change Record Detail - Multiple Scenarios with Descriptions
Department of Law

Component: Torts & Workers' Compensation (2719)
RDU: Civil Division (Excludes Janus) (35)

Scenario/Change Record Title	Trans Type	Totals	Personal Services	Travel	Services	Commodities	Capital Outlay	Grants, Benefits	Miscellaneous	Positions		NP
										PFT	PPT	
Transfer one full-time Attorney 5 position (03-0315), range 25, located in Anchorage, to the Commercial and Fair Business component from the Torts and Workers' Compensation component to keep pace with the required level of legal expertise needed within the office. The remaining staff in Torts and Workers' Compensation are sufficient to accommodate anticipated workload.												
Transfer Law Office Assistant (03-0204) to Transportation to Address Workload Demands												
	Trout	0.0	0.0	0.0	0.0	0.0	0.0	0.0	0.0	-1	0	0
Transfer a full-time Law Office Assistant 1 (03-0204), range 11, located in Anchorage, to the Transportation component from the Torts and Workers' Compensation component to accommodate workload demands. The remaining staff in Torts and Workers' Compensation are sufficient to cover the anticipated workload.												
Realign PERS Rate Adjustment by Fund Source Ch9 SLA2021 (SB55)												
	FndChg	0.0	0.0	0.0	0.0	0.0	0.0	0.0	0.0	0	0	0
1004 Gen Fund		-142.3										
1007 I/A Rcpts		142.3										
Remove one-time UGF subsidy for rate agency assigned in SB55 fiscal note (Ch 9 SLA 2021).												
Totals		4,420.3	4,275.8	17.2	93.7	33.6	0.0	0.0	0.0	32	0	0

Line Item Detail (1676)
Department of Law
Travel

Component: Torts & Workers' Compensation (2719)

Line Number	Line Name		FY2021 Actuals	FY2022 Management Plan	FY2023 Governor
2000	Travel		7.2	17.2	17.2
Object Class	Servicing Agency	Explanation	FY2021 Actuals	FY2022 Management Plan	FY2023 Governor
2000 Travel Detail Totals			7.2	17.2	17.2
2000	In-State Employee Travel	Travel for attorneys to interview witnesses and attend court proceedings, as well as for necessary training for both attorneys and paraprofessionals. Includes travel for management purposes.	0.2	13.5	13.5
2001	In-State Non-Employee Travel	Travel costs for witnesses to testify in court.	0.0	1.0	1.0
2002	Out of State Employee Travel	Travel costs and expenses for out-of-state travel for conferences, training, etc.	0.0	1.7	1.7
2006	Other Travel Costs	Travel cost transfers.	7.0	1.0	1.0

Line Item Detail (1676)
Department of Law
Services

Component: Torts & Workers' Compensation (2719)

Line Number	Line Name		FY2021 Actuals	FY2022 Management Plan	FY2023 Governor
3000	Services		621.4	93.7	93.7
Object Class	Servicing Agency	Explanation	FY2021 Actuals	FY2022 Management Plan	FY2023 Governor
3000 Services Detail Totals			621.4	93.7	93.7
3000	Education Services	Conferences, training and memberships.	10.6	10.6	10.6
3002	Legal and Judicial Services	Depositions, research costs, expert witness and consultant fees.	105.3	25.0	25.0
3006	Delivery Services	Freight, courier, postage, and transportation of trial exhibit materials.	0.9	0.9	0.9
3011	Other Services	Cost transfers and miscellaneous items within the services line (commissions, etc.).	504.6	57.2	57.2

Line Item Detail (1676)
Department of Law
Commodities

Component: Torts & Workers' Compensation (2719)

Line Number	Line Name		FY2021 Actuals	FY2022 Management Plan	FY2023 Governor
4000	Commodities		36.1	33.6	33.6
Object Class	Servicing Agency	Explanation	FY2021 Actuals	FY2022 Management Plan	FY2023 Governor
4000 Commodities Detail Totals			36.1	33.6	33.6
4000	Business	Reference materials and subscriptions, including statutes, software applications, non-capital desktop refresh, and miscellaneous office supplies.	0.0	1.0	1.0
4022	Commodity Transfer	Commodity cost transfers.	36.1	32.6	32.6

Line Item Detail (1676)

**Department of Law
Capital Outlay**

Component: Torts & Workers' Compensation (2719)

Line Number	Line Name		FY2021 Actuals	FY2022 Management Plan	FY2023 Governor
5000	Capital Outlay		12.5	0.0	0.0
Object Class	Servicing Agency	Explanation	FY2021 Actuals	FY2022 Management Plan	FY2023 Governor
5000 Capital Outlay Detail Totals			12.5	0.0	0.0
5009	Capital Outlay Transfer	Capital cost transfers.	12.5	0.0	0.0

Revenue Detail (1681)
Department of Law

Component: Torts & Workers' Compensation (2719)

Revenue Type (OMB Fund Code) Revenue Source	Component	Comment	FY2021 Actuals	FY2022 Management Plan	FY2023 Governor
5007 I/A Rcpts (1007 I/A Rcpts)			3,790.0	4,300.1	4,344.9
5301 Inter-Agency Receipts	Admin - Department-wide	RSA Administration, Risk Management - legal services regarding personal injury litigation. Program code: CV03214539.	3,290.7	3,800.1	3,844.9
5301 Inter-Agency Receipts	Correct - Department-wide	RSA Corrections, Department-wide - legal services. Program code: CV03214550.	499.3	500.0	500.0

Personal Services Expenditure Detail
Department of Law

Scenario: FY2023 Governor (18673)
Component: Torts & Workers' Compensation (2719)
RDU: Civil Division (Excludes Janus) (35)

PCN	Job Class Title	Time Status	Retire Code	Barg Unit	Location	Salary Sched	Range / Step	Comp Months	Split / Count	Annual Salaries	COLA	Premium Pay	Annual Benefits	Total Costs	UGF Amount
03-0030	Attorney 4	FT	A	XE	Juneau	N05	24F	12.0		111,774	0	0	61,851	173,625	0
03-0043	Attorney 5	FT	A	XE	Anchorage	N00	25L	12.0		125,931	0	0	67,121	193,052	0
03-0089	Attorney 6	FT	A	XE	Anchorage	N00	26Q / R	12.0		158,067	0	0	78,389	236,456	0
03-0109	Associate Attorney 1	FT	A	XE	Juneau	N05	17L	12.0		76,947	0	0	48,885	125,832	0
03-0127	Law Office Assistant 1	FT	A	GP	Anchorage	200	11B / C	12.0		38,969	0	0	33,290	72,259	0
03-0132	Paralegal 2	FT	A	GP	Fairbanks	203	16L	6.0	**	36,894	0	0	23,126	60,020	0
03-0142	Attorney 4	FT	A	XE	Anchorage	N00	24F	12.0		106,451	0	0	59,869	166,320	0
03-0171	Law Office Assistant 1	FT	A	GP	Fairbanks	203	11C / D	12.0		41,420	0	0	34,202	75,622	0
03-0201	Law Office Assistant 1	FT	A	GP	Anchorage	200	11B / C	12.0		39,016	0	0	33,307	72,323	0
03-0214	Paralegal 2	FT	A	GP	Anchorage	200	16A / B	12.0		53,193	0	0	38,585	91,778	0
03-0218	Paralegal 2	FT	A	GP	Anchorage	200	16K	12.0		69,381	0	0	44,612	113,993	0
03-0230	Attorney 5	FT	A	XE	Anchorage	N00	25P	12.0		143,130	0	0	73,525	216,655	0
03-0238	Attorney 2	FT	A	XE	Anchorage	N00	20F	12.0		81,393	0	0	50,540	131,933	0
03-0241	Attorney 4	FT	A	XE	Anchorage	N00	24C / D	12.0		98,312	0	0	56,839	155,151	0
03-0248	Law Office Assistant 2	FT	A	SS	Anchorage	600	13B / C	12.0		48,007	659	0	38,254	86,920	0
03-0255	Attorney 4	FT	A	XE	Anchorage	N00	24K	12.0		113,490	0	0	62,490	175,980	0
03-0286	Attorney 4	FT	A	XE	Anchorage	N00	24F / J	12.0		109,327	0	0	60,940	170,267	0
03-0287	Law Office Assistant 2	FT	A	SS	Anchorage	600	13B / C	12.0		48,541	666	0	38,453	87,660	0
03-0297	Law Office Assistant 1	FT	A	GP	Anchorage	200	11B / C	12.0		39,601	0	0	33,525	73,126	0
03-0300	Attorney 4	FT	A	XE	Anchorage	N00	24J	12.0		109,902	0	0	61,154	171,056	0
03-0321	Associate Attorney 2	FT	A	XE	Anchorage	N00	19D / E	12.0		72,199	0	0	47,117	119,316	0
03-0346	Paralegal 1	FT	A	GP	Anchorage	200	14A / B	12.0		47,093	0	0	36,314	83,407	0
03-0364	Attorney 5	FT	A	XE	Anchorage	N00	25K	12.0		121,973	0	0	65,648	187,621	0
03-0375	Attorney 2	FT	A	XE	Anchorage	N00	20C / D	12.0		75,379	0	0	48,301	123,680	0
03-0376	Associate Attorney 1	FT	A	XE	Anchorage	N00	17K	12.0		71,000	0	0	46,671	117,671	0
03-0384	Attorney 3	FT	A	XE	Anchorage	N00	22E / F	12.0		91,482	0	0	54,296	145,778	0
03-0427	Paralegal 2	FT	A	GP	Anchorage	200	16C / D	12.0		57,047	0	0	40,020	97,067	0
03-0430	Attorney 3	FT	A	XE	Anchorage	N00	22A / B	12.0		80,909	0	0	50,360	131,269	0
03-1038	Attorney 5	FT	A	XE	Fairbanks	N03	25N	12.0		138,294	0	0	71,724	210,018	0
03-1047	Law Office Assistant 2	FT	A	SS	Juneau	605	13D / E	12.0		54,020	741	0	40,493	95,254	0
03-1231	Attorney 4	FT	A	XE	Anchorage	N00	24F	12.0		106,451	0	0	59,869	166,320	0
06-0517	Attorney 5	FT	A	XE	Anchorage	N00	25F / J	12.0		115,445	0	0	63,217	178,662	0

Note: If a position is split, an asterisk (*) will appear in the Split/Count column. If the split position is also counted in the component, two asterisks (**) will appear in this column. [No valid job title] appearing in the Job Class Title indicates that the PCN has an invalid class code or invalid range for the class code effective date of this scenario.

Personal Services Expenditure Detail
Department of Law

Scenario: FY2023 Governor (18673)
Component: Torts & Workers' Compensation (2719)
RDU: Civil Division (Excludes Janus) (35)

PCN	Job Class Title	Time Status	Retire Code	Barg Unit	Location	Salary Sched	Range / Step	Comp Months	Split / Count	Annual Salaries	COLA	Premium Pay	Annual Benefits	Total Costs	UGF Amount
		Total Positions	New	Deleted										Total Salary Costs:	2,681,038
														Total COLA:	2,066
	Full Time Positions:	32	0	0										Total Premium Pay:	0
	Part Time Positions:	0	0	0										Total Benefits:	1,622,987
	Non Permanent Positions:	0	0	0											
	Positions in Component:	32	0	0											
	Total Component Months:	378.0												Total Pre-Vacancy:	4,306,091
														Minus Vacancy Adjustment of 0.70%:	(30,291)
														Total Post-Vacancy:	4,275,800
														Plus Lump Sum Premium Pay:	0
														Personal Services Line 100:	4,275,800

PCN Funding Sources:	Pre-Vacancy	Post-Vacancy	Percent
1007 Interagency Receipts	4,306,091	4,275,800	100.00%
Total PCN Funding:	4,306,091	4,275,800	100.00%

Note: If a position is split, an asterisk (*) will appear in the Split/Count column. If the split position is also counted in the component, two asterisks (**) will appear in this column. [No valid job title] appearing in the Job Class Title indicates that the PCN has an invalid class code or invalid range for the class code effective date of this scenario.

CIVIL DIVISION

Torts and Workers' Compensation

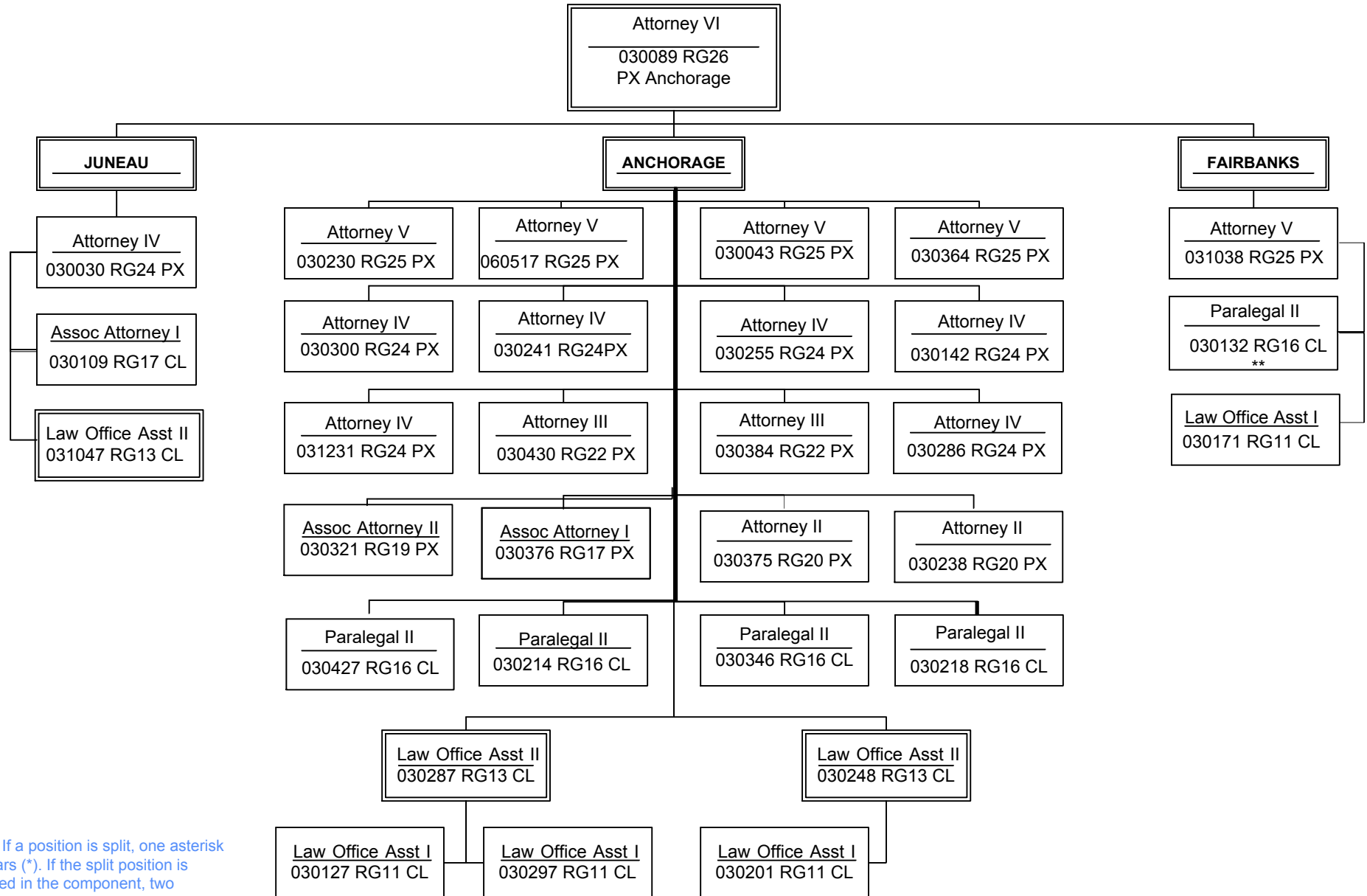

Note: If a position is split, one asterisk appears (*). If the split position is counted in the component, two asterisks (**) appear.

State of Alaska FY2023 Governor's Operating Budget

Department of Law Transportation Section Component Budget Summary

Component: Transportation Section**Contribution to Department's Mission**

The Transportation Section provides advice and legal representation to state agencies on all aspects of the construction and operation of the state's public facilities, including highways, international and rural airports, ferries, buildings, harbors, and other public works. The Department of Transportation and Public Facilities (DOTPF) generates a high percentage of the section's work.

Core Services

- Assist agencies with project development, including compliance with project planning and environmental laws.
- Assist agencies with project execution, including funding issues, land acquisition, procurement of contractors, and resolution of claims by contractors.
- Assist agencies with management and operation of completed facilities.
- Provide advice and representation on myriad issues daily confronting agencies related to development and operation of public infrastructure.
- Advise DOTPF in negotiations and disputes with federal funding agencies.

Major Component Accomplishments in 2021

Section attorneys provided legal support for DOTPF land acquisition for highway and airport projects throughout Alaska and defended multiple contractor claims filed against DOTPF. Included among the larger cases were claims arising from road construction and airport projects in DOTPF's Central and Southcoast regions. Land acquisitions were associated with major projects on the Parks, Glenn, Seward, and Richardson Highways, Knik-Goose Bay Road, and in the City of Fairbanks. Among these matters is the ongoing litigation against federal agencies regarding the proposed road between the communities of King Cove and Cold Bay. Section attorneys also assist DOTPF in the management of highway rights-of-way, and recovering repair costs following incidents where bridges or overpasses are seriously damaged by vehicle collisions.

Key Component Challenges

The section will continue assisting with implementation of the state's transportation and infrastructure programs. The section will continue helping state agencies with project development, including the resolution of environmental issues, land ownership and acquisition issues, contract specification and procurement issues, and any necessary changes to laws or regulations. The section will continue to advise and represent state agencies with eminent domain, bid protests, and construction claims. The section will help agencies manage and operate completed facilities, including ferry, international and rural airports, and highway facilities. Workload for the section is projected to grow due to the increased federal funding that is being made available for DOTPF infrastructure projects.

Significant Changes in Results to be Delivered in FY2023

No significant changes in results to be delivered.

Statutory and Regulatory Authority

AS 44.23.020

Contact Information

Contact: Max Garner, Chief Assistant Attorney General
Phone: (907) 269-5100
E-mail: max.garner@alaska.gov

Transportation Section Personal Services Information				
Authorized Positions			Personal Services Costs	
	<u>FY2022</u> <u>Management</u> <u>Plan</u>	<u>FY2023</u> <u>Governor</u>		
Full-time	14	14	Annual Salaries	1,505,112
Part-time	0	0	Premium Pay	0
Nonpermanent	0	0	Annual Benefits	836,805
			<i>Less 2.77% Vacancy Factor</i>	(64,817)
			Lump Sum Premium Pay	0
Totals	14	14	Total Personal Services	2,277,100

Position Classification Summary					
Job Class Title	Anchorage	Fairbanks	Juneau	Others	Total
Associate Attorney 1	1	0	0	0	1
Attorney 4	2	1	1	0	4
Attorney 5	2	0	3	0	5
Attorney 6	1	0	0	0	1
Law Office Assistant 1	1	1	1	0	3
Totals	7	2	5	0	14

Component Detail All Funds
Department of Law

Component: Transportation Section (2214)
RDU: Civil Division (Excludes Janus) (35)

Non-Formula Component

	FY2021 Actuals	FY2022 Conference Committee	FY2022 Authorized	FY2022 Management Plan	FY2023 Governor	FY2022 Management Plan vs FY2023 Governor	
71000 Personal Services	1,420.7	2,219.3	2,219.3	2,567.1	2,277.1	-290.0	-11.3%
72000 Travel	7.5	19.2	19.2	19.2	19.2	0.0	0.0%
73000 Services	535.9	481.0	481.0	481.0	481.0	0.0	0.0%
74000 Commodities	16.4	28.4	28.4	28.4	28.4	0.0	0.0%
75000 Capital Outlay	5.7	0.0	0.0	0.0	0.0	0.0	0.0%
77000 Grants, Benefits	0.0	0.0	0.0	0.0	0.0	0.0	0.0%
78000 Miscellaneous	0.0	0.0	0.0	0.0	0.0	0.0	0.0%
Totals	1,986.2	2,747.9	2,747.9	3,095.7	2,805.7	-290.0	-9.4%
Fund Sources:							
1004 Gen Fund (UGF)	4.6	112.5	112.5	112.5	26.2	-86.3	-76.7%
1007 I/A Rcpts (Other)	1,827.1	2,435.8	2,435.8	2,783.6	2,579.9	-203.7	-7.3%
1061 CIP Rcpts (Other)	154.5	199.6	199.6	199.6	199.6	0.0	0.0%
Unrestricted General (UGF)	4.6	112.5	112.5	112.5	26.2	-86.3	-76.7%
Designated General (DGF)	0.0	0.0	0.0	0.0	0.0	0.0	0.0%
Other Funds	1,981.6	2,635.4	2,635.4	2,983.2	2,779.5	-203.7	-6.8%
Federal Funds	0.0	0.0	0.0	0.0	0.0	0.0	0.0%
Positions:							
Permanent Full Time	13	13	13	14	14	0	0.0%
Permanent Part Time	0	0	0	0	0	0	0.0%
Non Permanent	0	0	0	0	0	0	0.0%

Change Record Detail - Multiple Scenarios with Descriptions
Department of Law

Component: Transportation Section (2214)
RDU: Civil Division (Excludes Janus) (35)

Scenario/Change Record Title	Trans Type	Totals	Personal Services	Travel	Services	Commodities	Capital Outlay	Grants, Benefits	Miscellaneous	Positions		NP
										PFT	PPT	
***** Changes From FY2022 Conference Committee To FY2022 Authorized *****												
FY2022 Conference Committee												
	ConfCom	2,747.9	2,219.3	19.2	481.0	28.4	0.0	0.0	0.0	13	0	0
1004 Gen Fund		112.5										
1007 I/A Rcpts		2,435.8										
1061 CIP Rcpts		199.6										
Subtotal		2,747.9	2,219.3	19.2	481.0	28.4	0.0	0.0	0.0	13	0	0
***** Changes From FY2022 Authorized To FY2022 Management Plan *****												
Transfer Two Attorney Positions from Commercial and Fair Business for Required Legal Expertise												
	Trin	347.8	347.8	0.0	0.0	0.0	0.0	0.0	0.0	2	0	0
1007 I/A Rcpts		347.8										
Transfer two full-time Attorney 4 positions (03-0044 and 03-0094), range 24, located in Juneau and Anchorage, from the Commercial and Fair Business component to the Transportation component to keep pace with the required level of legal expertise needed within the office. The remaining staff in Commercial and Fair Business are sufficient to accommodate anticipated workload.												
Transfer Law Office Assistant 1 (03-0171) to Torts and Workers' Compensation to Address Workload Demands												
	Trout	0.0	0.0	0.0	0.0	0.0	0.0	0.0	0.0	-1	0	0
Transfer a full-time Law Office Assistant 1 (03-0171), range 11, located in Fairbanks, to the Torts and Workers' Compensation component from the Transportation component to accommodate workload demands. The remaining staff in Transportation are sufficient to cover the anticipated workload.												
Subtotal		3,095.7	2,567.1	19.2	481.0	28.4	0.0	0.0	0.0	14	0	0
***** Changes From FY2022 Management Plan To FY2023 Governor *****												
FY2023 Executive Health Insurance, SBS, and Risk Management Rate Changes												
	SalAdj	21.7	21.7	0.0	0.0	0.0	0.0	0.0	0.0	0	0	0
1007 I/A Rcpts		21.7										
FY2023 Change Partially Exempt & Exempt Executive (EE) - Health Insurance from \$1,555 to \$1,685; SBS and Risk Management Rates: \$21.7												
FY2023 General Government Unit SBS and Risk Management Rate Changes												
	SalAdj	0.6	0.6	0.0	0.0	0.0	0.0	0.0	0.0	0	0	0
1007 I/A Rcpts		0.6										
FY2023 Change General Government Unit (GG, GP, GY, GZ) - SBS, and Risk Management Rates: \$0.6												
FY2023 PERS Actuarial Rate Adjustment to 24.79% Ch9 SLA2021 (SB55)												
	SalAdj	-86.3	-86.3	0.0	0.0	0.0	0.0	0.0	0.0	0	0	0

Change Record Detail - Multiple Scenarios with Descriptions
Department of Law

Component: Transportation Section (2214)
RDU: Civil Division (Excludes Janus) (35)

Scenario/Change Record Title	Trans Type	Totals	Personal Services	Travel	Services	Commodities	Capital Outlay	Grants, Benefits	Miscellaneous	Positions		NP	
										PFT	PPT		
1007 I/A Rcpts		-86.3											
Includes: FY2023 Adjustment for PERS ARM Board Approved Rate of 24.79% (from 30.11%): \$-86.3													
Transfer Law Office Assistant (03-0204) from Torts and Workers' Compensation to Address Workload Demands													
	Trin	0.0	0.0	0.0	0.0	0.0	0.0	0.0	0.0	0.0	1	0	0
Transfer a full-time Law Office Assistant 1 (03-0204), range 11, located in Anchorage, from the Torts and Workers' Compensation component to the Transportation component to accommodate workload demands. The remaining staff in Torts and Workers' Compensation are sufficient to cover the anticipated workload.													
Transfer Attorney 5 (03-0069) to Commercial and Fair Business for Required Legal Expertise													
	Trout	-226.0	-226.0	0.0	0.0	0.0	0.0	0.0	0.0	0.0	-1	0	0
1007 I/A Rcpts		-226.0											
Transfer one full-time Attorney 5 position (03-0069), range 25, located in Anchorage, to the Commercial and Fair Business component from the Transportation component to keep pace with the required level of legal expertise needed within the office. The remaining staff in Transportation are sufficient to accommodate anticipated workload.													
Realign PERS Rate Adjustment by Fund Source Ch9 SLA2021 (SB55)													
	FndChg	0.0	0.0	0.0	0.0	0.0	0.0	0.0	0.0	0.0	0	0	0
1004 Gen Fund		-86.3											
1007 I/A Rcpts		86.3											
Remove one-time UGF subsidy for rate agency assigned in SB55 fiscal note (Ch 9 SLA 2021).													
Totals		2,805.7	2,277.1	19.2	481.0	28.4	0.0	0.0	0.0	0.0	14	0	0

Line Item Detail (1676)
Department of Law
Travel

Component: Transportation Section (2214)

Line Number	Line Name		FY2021 Actuals	FY2022 Management Plan	FY2023 Governor
2000	Travel		7.5	19.2	19.2
Object Class	Servicing Agency	Explanation	FY2021 Actuals	FY2022 Management Plan	FY2023 Governor
2000 Travel Detail Totals			7.5	19.2	19.2
2000	In-State Employee Travel	Travel for attorneys to interview witnesses and attend court proceedings, as well as for necessary training for both attorneys and paraprofessionals. Includes travel for management purposes.	2.5	6.1	6.1
2001	In-State Non-Employee Travel	Travel costs for witnesses to testify in court.	0.0	5.0	5.0
2002	Out of State Employee Travel	Travel costs and expenses for out-of-state travel for conferences, training, etc.	1.8	6.1	6.1
2006	Other Travel Costs	Travel cost transfers.	3.2	2.0	2.0

Line Item Detail (1676)
Department of Law
Services

Component: Transportation Section (2214)

Line Number	Line Name		FY2021 Actuals	FY2022 Management Plan	FY2023 Governor
3000	Services		535.9	481.0	481.0
Object Class	Servicing Agency	Explanation	FY2021 Actuals	FY2022 Management Plan	FY2023 Governor
3000 Services Detail Totals			535.9	481.0	481.0
3000	Education Services	Conferences, training and memberships.	5.5	3.0	3.0
3002	Legal and Judicial Services	Depositions, research costs, expert witness and consultant fees.	299.3	299.3	299.3
3006	Delivery Services	Freight, courier, postage, and transportation of trial exhibit materials.	0.2	1.8	1.8
3011	Other Services	Cost transfers and miscellaneous items within the services line (commissions, etc.).	230.4	175.9	175.9
3029	Inter-Agency Education/Training	Classes and training offered by another state department.	0.5	1.0	1.0

Line Item Detail (1676)
Department of Law
Commodities

Component: Transportation Section (2214)

Line Number	Line Name		FY2021 Actuals	FY2022 Management Plan	FY2023 Governor
4000	Commodities		16.4	28.4	28.4
Object Class	Servicing Agency	Explanation	FY2021 Actuals	FY2022 Management Plan	FY2023 Governor
4000 Commodities Detail Totals			16.4	28.4	28.4
4000	Business	Reference materials and subscriptions, including statutes, software applications, non-capital desktop refresh, and miscellaneous office supplies.	0.0	1.7	1.7
4022	Commodity Transfer	Commodity cost transfers.	16.4	26.7	26.7

Line Item Detail (1676)
Department of Law
Capital Outlay

Component: Transportation Section (2214)

Line Number	Line Name		FY2021 Actuals	FY2022 Management Plan	FY2023 Governor
5000	Capital Outlay		5.7	0.0	0.0
Object Class	Servicing Agency	Explanation	FY2021 Actuals	FY2022 Management Plan	FY2023 Governor
5000 Capital Outlay Detail Totals			5.7	0.0	0.0
5009	Capital Outlay Transfer	Capital cost transfers.	5.7	0.0	0.0

Revenue Detail (1681)
Department of Law

Component: Transportation Section (2214)

Revenue Type (OMB Fund Code) Revenue Source	Component	Comment	FY2021 Actuals	FY2022 Management Plan	FY2023 Governor
5007 I/A Rcpts (1007 I/A Rcpts)			1,827.1	2,783.6	2,579.9
5301 Inter-Agency Receipts	Trans - Department-wide	RSA Transportation, Department-wide - legal services. Program code: CV03215522.	1,364.2	2,233.6	1,885.8
5301 Inter-Agency Receipts	Trans - Department-wide	RSA Transportation, Alaska International Airport System - legal services for the Anchorage and Fairbanks international airports. Program code: CV03215538.	298.4	300.0	347.1
5301 Inter-Agency Receipts	Trans - Department-wide	RSA Transportation, Alaska Marine Highway System - legal services. Program code: CV03215546.	164.5	250.0	347.0
5061 CIP Rcpts (1061 CIP Rcpts)			154.5	199.6	199.6
5351 Capital Improvement Project Inter-Agency	NatRes - Department-wide	RSA Natural Resources, Parks and Outdoor Recreation - legal services for the Denali State Park claim. Program code: CV03215550.	14.4	49.6	49.6
5351 Capital Improvement Project Inter-Agency	Trans - Department-wide	RSA Transportation, Shelter Cove Road legal services (Arcadis). Program code: CV03215645.	96.3	100.0	100.0
5351 Capital Improvement Project Inter-Agency	Trans - Department-wide	RSA Transportation - legal services related to stormwater permitting and compliance. Program code: CVTRA25001.	43.8	50.0	50.0

Personal Services Expenditure Detail
Department of Law

Scenario: FY2023 Governor (18673)
Component: Transportation Section (2214)
RDU: Civil Division (Excludes Janus) (35)

PCN	Job Class Title	Time Status	Retire Code	Barg Unit	Location	Salary Sched	Range / Step	Comp Months	Split / Count	Annual Salaries	COLA	Premium Pay	Annual Benefits	Total Costs	UGF Amount
03-0044	Attorney 4	FT	A	XE	Juneau	N05	24F	12.0		111,774	0	0	61,851	173,625	0
03-0065	Law Office Assistant 1	FT	A	GP	Anchorage	200	11B	12.0		38,922	0	0	33,272	72,194	0
03-0084	Associate Attorney 1	FT	A	GP	Anchorage	200	17O / P	12.0		84,620	0	0	50,285	134,905	0
03-0094	Attorney 4	FT	A	XE	Anchorage	N00	24F	12.0		106,451	0	0	59,869	166,320	0
03-0115	Attorney 5	FT	A	XE	Anchorage	N00	25F	12.0		114,426	0	0	62,838	177,264	0
03-0132	Paralegal 2	FT	A	GP	Fairbanks	203	16L	6.0	*	36,894	0	0	23,126	60,020	0
03-0169	Attorney 6	FT	A	XE	Anchorage	N00	26L	12.0		156,824	0	0	78,002	234,826	0
03-0204	Law Office Assistant 1	FT	A	GP	Fairbanks	203	11B	6.0	**	20,144	0	0	16,890	37,034	0
03-0207	Attorney 4	FT	A	XE	Anchorage	N00	24F / J	12.0		109,844	0	0	61,132	170,976	0
03-0217	Law Office Assistant 1	FT	A	GP	Juneau	205	11D / E	12.0		43,469	0	0	34,965	78,434	0
03-0294	Attorney 5	FT	A	XE	Juneau	99	25P / Q	12.0		153,633	0	0	77,010	230,643	0
03-0312	Attorney 5	FT	A	XE	Juneau	N05	25K	12.0		128,076	0	0	67,920	195,996	0
03-0314	Attorney 4	FT	A	XE	Fairbanks	99	24O	12.0		140,041	0	0	72,375	212,416	0
03-0391	Attorney 5	FT	A	XE	Juneau	N05	25O	12.0		145,568	0	0	74,432	220,000	0
03-1211	Attorney 5	FT	A	XE	Anchorage	N00	25F	12.0		114,426	0	0	62,838	177,264	0

	Total Positions	New	Deleted		Total Salary Costs:	1,505,112
					Total COLA:	0
Full Time Positions:	14	0	0		Total Premium Pay:	0
Part Time Positions:	0	0	0		Total Benefits:	836,805
Non Permanent Positions:	0	0	0			
Positions in Component:	14	0	0		Total Pre-Vacancy:	2,341,917
					Minus Vacancy Adjustment of 2.77%:	(64,817)
					Total Post-Vacancy:	2,277,100
Total Component Months:	168.0				Plus Lump Sum Premium Pay:	0
					Personal Services Line 100:	2,277,100

PCN Funding Sources:	Pre-Vacancy	Post-Vacancy	Percent
1007 Interagency Receipts	2,341,917	2,277,100	100.00%
Total PCN Funding:	2,341,917	2,277,100	100.00%

Note: If a position is split, an asterisk (*) will appear in the Split/Count column. If the split position is also counted in the component, two asterisks (**) will appear in this column. [No valid job title] appearing in the Job Class Title indicates that the PCN has an invalid class code or invalid range for the class code effective date of this scenario.

CIVIL DIVISION

Transportation Section

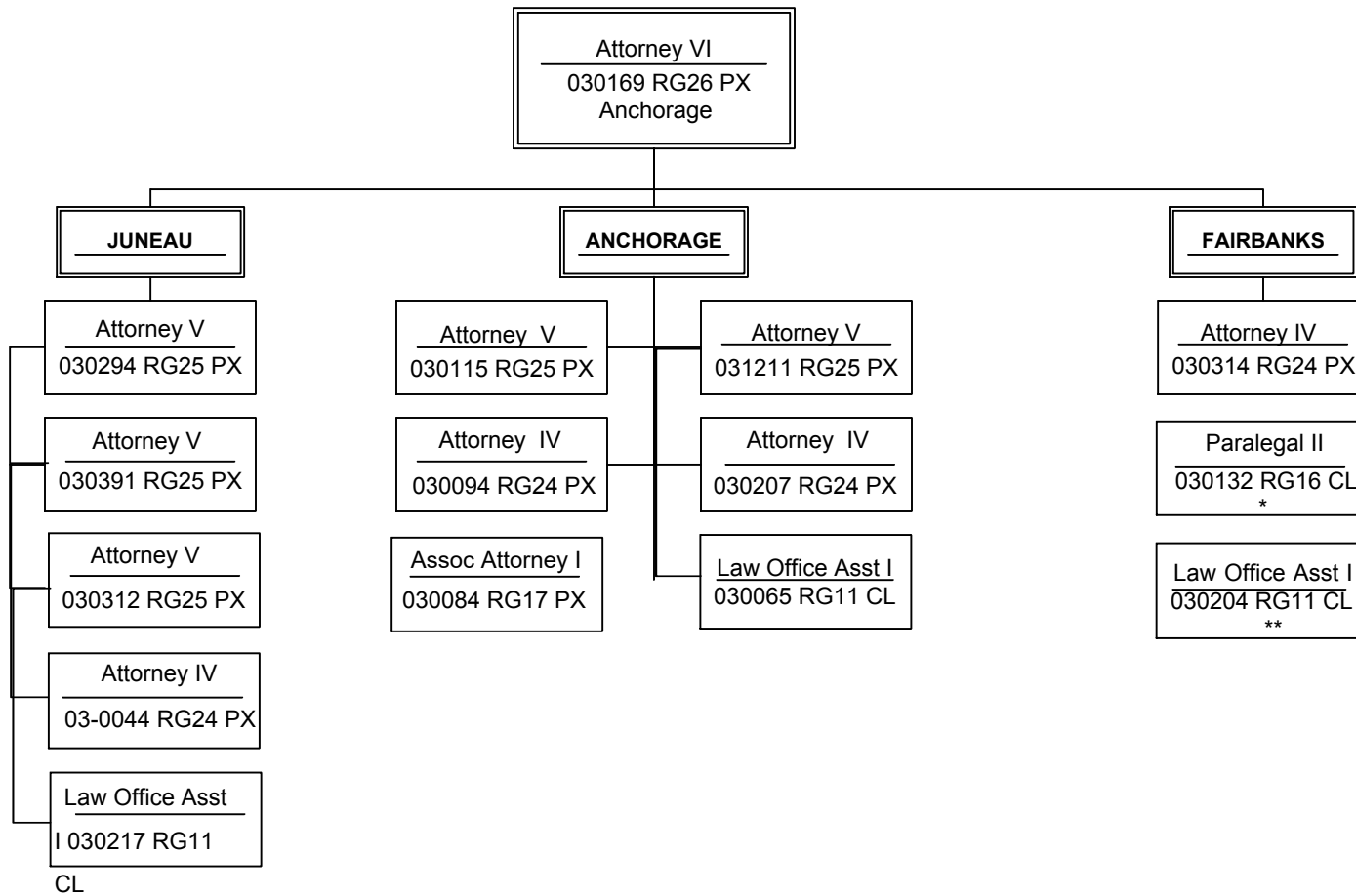

State of Alaska
FY2023 Governor's Operating Budget

Department of Law
Administration and Support
Results Delivery Unit Budget Summary

Administration and Support Results Delivery Unit

Contribution to Department's Mission

The mission of Administration and Support is to provide leadership, support, and oversight of department operations in the furtherance of the department's mission to provide legal services to state agencies, to ensure that civil and criminal laws of the state are followed, to defend the state in legal actions, and to implement the Executive Branch Ethics Act.

Core Services

- Protecting the safety and physical and financial well-being of Alaskans.
- Fostering the conditions for economic opportunity and responsible development and use of our natural resources.
- Protecting the fiscal integrity of the State of Alaska.
- Promoting and defending good governance.

Major RDU Accomplishments in 2021

Major accomplishments are included at the department level and at the Administrative Services component level.

Key RDU Challenges

Key challenges are included at the department level and at the Administrative Services component level.

Significant Changes in Results to be Delivered in FY2023

Changes in results to be delivered are included at the department level and at the Administrative Services component level.

Contact Information

Contact: Ed Sniffen, Acting Attorney General
Phone: (907) 269-5100
E-mail: ed.sniffen@alaska.gov

**Administration and Support
RDU Financial Summary by Component**

All dollars shown in thousands

	FY2021 Actuals				FY2022 Management Plan				FY2023 Governor			
	UGF+DGF Funds	Other Funds	Federal Funds	Total Funds	UGF+DGF Funds	Other Funds	Federal Funds	Total Funds	UGF+DGF Funds	Other Funds	Federal Funds	Total Funds
Formula Expenditures None.												
Non-Formula Expenditures												
Office of the Attorney General	344.3	658.5	0.0	1,002.8	551.6	188.5	0.0	740.1	534.6	190.8	0.0	725.4
Administrative Services	1,109.1	1,178.0	0.0	2,287.1	1,323.6	1,948.5	0.0	3,272.1	1,282.9	1,939.5	0.0	3,222.4
Dept of Law State Facilities Rnt	846.3	0.0	0.0	846.3	846.3	0.0	0.0	846.3	846.3	0.0	0.0	846.3
Totals	2,299.7	1,836.5	0.0	4,136.2	2,721.5	2,137.0	0.0	4,858.5	2,663.8	2,130.3	0.0	4,794.1

Administration and Support
Summary of RDU Budget Changes by Component
From FY2022 Management Plan to FY2023 Governor

All dollars shown in thousands

	<u>Unrestricted Gen (UGF)</u>	<u>Designated Gen (DGF)</u>	<u>Other Funds</u>	<u>Federal Funds</u>	<u>Total Funds</u>
FY2022 Management Plan	2,721.5	0.0	2,137.0	0.0	4,858.5
Adjustments which continue current level of service:					
-Office of the Attorney General	-17.0	0.0	2.3	0.0	-14.7
-Administrative Services	-40.7	0.0	-9.0	0.0	-49.7
FY2023 Governor	2,663.8	0.0	2,130.3	0.0	4,794.1

State of Alaska FY2023 Governor's Operating Budget

Department of Law Office of the Attorney General Component Budget Summary

Component: Office of the Attorney General

Contribution to Department's Mission

The Attorney General is the state's chief law enforcement officer, overseeing the state's involvement in all civil matters and criminal prosecutions, and leading over 500 attorneys and staff in the Department of Law's twelve offices throughout the state. The Attorney General serves as co-chair with the Chief Justice of the Alaska Supreme Court of the Alaska Criminal Justice Working Group and trustee on the Exxon Valdez Oil Spill Trustee Council.

Core Services

- Protecting the safety and physical and financial well-being of Alaskans.
- Fostering the conditions for economic opportunity and for the responsible development and use of our natural resources.
- Protecting the fiscal integrity of the State of Alaska.
- Promoting and defending good governance.

Major Component Accomplishments in 2021

Major accomplishments are shown at the department level.

Key Component Challenges

Key component challenges are shown at the department level.

Significant Changes in Results to be Delivered in FY2023

Changes in results are shown at the department level.

Statutory and Regulatory Authority

AS 44.23.020

Contact Information

Contact: Treg Taylor, Attorney General
Phone: (907) 269-5100
E-mail: treg.taylor@alaska.gov

Office of the Attorney General Personal Services Information				
Authorized Positions			Personal Services Costs	
	<u>FY2022</u> <u>Management</u> <u>Plan</u>	<u>FY2023</u> <u>Governor</u>		
Full-time	4	4	Annual Salaries	430,532
Part-time	0	0	Premium Pay	0
Nonpermanent	0	0	Annual Benefits	239,826
			<i>Less 1.65% Vacancy Factor</i>	(11,058)
			Lump Sum Premium Pay	0
Totals	4	4	Total Personal Services	659,300

Position Classification Summary					
Job Class Title	Anchorage	Fairbanks	Juneau	Others	Total
Commissioner	1	0	0	0	1
Executive Secretary 3	1	0	0	0	1
Sp Asst Commr 2	2	0	0	0	2
Totals	4	0	0	0	4

Component Detail All Funds
Department of Law

Component: Office of the Attorney General (2162)
RDU: Administration and Support (280)

Non-Formula Component

	FY2021 Actuals	FY2022 Conference Committee	FY2022 Authorized	FY2022 Management Plan	FY2023 Governor	FY2022 Management Plan vs FY2023 Governor	
71000 Personal Services	665.1	649.0	649.0	664.0	659.3	-4.7	-0.7%
72000 Travel	10.5	39.3	39.3	39.3	39.3	0.0	0.0%
73000 Services	243.2	38.8	38.8	23.8	13.8	-10.0	-42.0%
74000 Commodities	30.1	13.0	13.0	13.0	13.0	0.0	0.0%
75000 Capital Outlay	53.9	0.0	0.0	0.0	0.0	0.0	0.0%
77000 Grants, Benefits	0.0	0.0	0.0	0.0	0.0	0.0	0.0%
78000 Miscellaneous	0.0	0.0	0.0	0.0	0.0	0.0	0.0%
Totals	1,002.8	740.1	740.1	740.1	725.4	-14.7	-2.0%
Fund Sources:							
1004 Gen Fund (UGF)	344.3	551.6	551.6	551.6	534.6	-17.0	-3.1%
1007 I/A Rcpts (Other)	658.5	188.5	188.5	188.5	190.8	2.3	1.2%
Unrestricted General (UGF)	344.3	551.6	551.6	551.6	534.6	-17.0	-3.1%
Designated General (DGF)	0.0	0.0	0.0	0.0	0.0	0.0	0.0%
Other Funds	658.5	188.5	188.5	188.5	190.8	2.3	1.2%
Federal Funds	0.0	0.0	0.0	0.0	0.0	0.0	0.0%
Positions:							
Permanent Full Time	5	4	4	4	4	0	0.0%
Permanent Part Time	0	0	0	0	0	0	0.0%
Non Permanent	0	0	0	0	0	0	0.0%

Change Record Detail - Multiple Scenarios with Descriptions
Department of Law

Component: Office of the Attorney General (2162)
RDU: Administration and Support (280)

Scenario/Change Record Title	Trans Type	Totals	Personal Services	Travel	Services	Commodities	Capital Outlay	Grants, Benefits	Miscellaneous	Positions		NP
										PFT	PPT	
***** Changes From FY2022 Conference Committee To FY2022 Authorized *****												
FY2022 Conference Committee												
	ConfCom	740.1	649.0	39.3	38.8	13.0	0.0	0.0	0.0	4	0	0
1004 Gen Fund		551.6										
1007 I/A Rcpts		188.5										
Subtotal		740.1	649.0	39.3	38.8	13.0	0.0	0.0	0.0	4	0	0
***** Changes From FY2022 Authorized To FY2022 Management Plan *****												
Transfer Authority from Services for Anticipated Personal Service Expenditures												
	LIT	0.0	15.0	0.0	-15.0	0.0	0.0	0.0	0.0	0	0	0
Transfer authority from the services line to the personal services line for anticipated personal services costs. The remaining services authority is anticipated to be sufficient to cover operating expenditures.												
Subtotal		740.1	664.0	39.3	23.8	13.0	0.0	0.0	0.0	4	0	0
***** Changes From FY2022 Management Plan To FY2023 Governor *****												
FY2023 Executive Health Insurance, SBS, and Risk Management Rate Changes												
	SalAdj	7.6	7.6	0.0	0.0	0.0	0.0	0.0	0.0	0	0	0
1004 Gen Fund		5.3										
1007 I/A Rcpts		2.3										
FY2023 Change Partially Exempt & Exempt Executive (EE) - Health Insurance from \$1,555 to \$1,685; SBS and Risk Management Rates: \$7.6												
FY2023 PERS Actuarial Rate Adjustment to 24.79% Ch9 SLA2021 (SB55)												
	SalAdj	-22.3	-22.3	0.0	0.0	0.0	0.0	0.0	0.0	0	0	0
1004 Gen Fund		-16.1										
1007 I/A Rcpts		-6.2										
Includes: FY2023 Adjustment for PERS ARM Board Approved Rate of 24.79% (from 30.11%): \$-22.3												
Realign PERS Rate Adjustment by Fund Source Ch9 SLA2021 (SB55)												
	FndChg	0.0	0.0	0.0	0.0	0.0	0.0	0.0	0.0	0	0	0
1004 Gen Fund		-6.2										
1007 I/A Rcpts		6.2										
Remove one-time UGF subsidy for rate agency assigned in SB55 fiscal note (Ch 9 SLA 2021).												
Transfer Authority to Personal Services for Anticipated Expenditures												
	LIT	0.0	10.0	0.0	-10.0	0.0	0.0	0.0	0.0	0	0	0

Change Record Detail - Multiple Scenarios with Descriptions
Department of Law

Component: Office of the Attorney General (2162)
RDU: Administration and Support (280)

Scenario/Change Record Title	Trans Type	Totals	Personal Services	Travel	Services	Commodities	Capital Outlay	Grants, Benefits	Miscellaneous	Positions		
										PFT	PPT	NP
Transfer authority to the personal services line from the services line for anticipated costs. The remaining services authority is anticipated to be sufficient to cover operating expenditures.												
	Totals	725.4	659.3	39.3	13.8	13.0	0.0	0.0	0.0	4	0	0

Line Item Detail (1676)
Department of Law
Travel

Component: Office of the Attorney General (2162)

Line Number	Line Name		FY2021 Actuals	FY2022 Management Plan	FY2023 Governor
2000	Travel		10.5	39.3	39.3
Object Class	Servicing Agency	Explanation	FY2021 Actuals	FY2022 Management Plan	FY2023 Governor
2000 Travel Detail Totals			10.5	39.3	39.3
2000	In-State Employee Travel	Travel for attorneys to interview witnesses and attend court proceedings, as well as for necessary training for both attorneys and paraprofessionals. Includes travel for management purposes.	10.5	24.3	24.3
2002	Out of State Employee Travel	Travel costs and expenses for out-of-state travel for conferences, training, etc.	0.0	15.0	15.0

Line Item Detail (1676)
Department of Law
Services

Component: Office of the Attorney General (2162)

Line Number	Line Name		FY2021 Actuals	FY2022 Management Plan	FY2023 Governor
3000	Services		243.2	23.8	13.8
Object Class	Servicing Agency	Explanation	FY2021 Actuals	FY2022 Management Plan	FY2023 Governor
3000 Services Detail Totals			243.2	23.8	13.8
3000	Education Services	Conferences, training and memberships.	32.8	3.9	3.9
3002	Legal and Judicial Services	Depositions, research costs, expert witness and consultant fees.	9.6	0.6	0.6
3003	Information Technology	Training, consulting and software licensing and maintenance. Annual maintenance fee for mission-critical information management systems.	102.3	10.1	0.1
3004	Telecommunications	Local telephone service, long distance charges and cellular phone services paid to third-party telephone utilities.	5.9	1.8	1.8
3007	Advertising and Promotions	Publication of legal notices.	0.1	0.1	0.1
3009	Structure/Infrastructure/Land	Rentals/leases - records and evidence storage.	0.1	0.1	0.1
3011	Other Services	Cost transfers and miscellaneous items within the services line (commissions, etc.).	0.1	0.1	0.1
3013	Inter-Agency Data Processing Operations Allocation	Law - Administrative Services (2164) RSA Law, Information services, data processing investments and support.	1.9	0.1	0.1
3017	Inter-Agency Information Technology Non-Telecommunications	Admin - Department-wide RSA Administration, Office of Information Technology computer services.	20.0	1.9	1.9
3018	Inter-Agency Information Technology Telecommunications	Admin - Department-wide RSA Administration, Office of Information Technology telecommunications services.	2.6	1.1	1.1

Line Item Detail (1676)
Department of Law
Services

Component: Office of the Attorney General (2162)

Object Class	Servicing Agency	Explanation	FY2021 Actuals	FY2022 Management Plan	FY2023 Governor
3000 Services Detail Totals			243.2	23.8	13.8
3022	Inter-Agency Human Resources	Law - Administrative Services (2164) RSA Law, Human Resources position.	4.6	2.7	2.7
3023	Inter-Agency Building Leases	Admin - Department-wide Leased office space managed by General Services.	47.1	0.5	0.5
3026	Inter-Agency Insurance	Admin - Department-wide RSA Administration, Risk Management.	15.3	0.1	0.1
3027	Inter-Agency Financial	Admin - Department-wide RSA Administration, Finance Chargeback (IRIS).	0.8	0.7	0.7

Line Item Detail (1676)

**Department of Law
Commodities**

Component: Office of the Attorney General (2162)

Line Number	Line Name		FY2021 Actuals	FY2022 Management Plan	FY2023 Governor
4000	Commodities		30.1	13.0	13.0
Object Class	Servicing Agency	Explanation	FY2021 Actuals	FY2022 Management Plan	FY2023 Governor
4000 Commodities Detail Totals			30.1	13.0	13.0
4000	Business	Reference materials and subscriptions, including statutes, software applications, non-capital desktop refresh, and miscellaneous office supplies.	30.0	12.5	12.5
4002	Household/Institutional	Institutional supplies for cleaning and maintenance.	0.1	0.5	0.5

Line Item Detail (1676)
Department of Law
Capital Outlay

Component: Office of the Attorney General (2162)

Line Number	Line Name		FY2021 Actuals	FY2022 Management Plan	FY2023 Governor
5000	Capital Outlay		53.9	0.0	0.0
Object Class	Servicing Agency	Explanation	FY2021 Actuals	FY2022 Management Plan	FY2023 Governor
5000 Capital Outlay Detail Totals			53.9	0.0	0.0
5004	Equipment	Equipment purchases.	53.9	0.0	0.0

Revenue Detail (1681)
Department of Law

Component: Office of the Attorney General (2162)

Revenue Type (OMB Fund Code) Revenue Source	Component	Comment	FY2021 Actuals	FY2022 Management Plan	FY2023 Governor
5007 I/A Rcpts (1007 I/A Rcpts)			658.5	188.5	190.8
5301 Inter-Agency Receipts	Law - Dep. Attny General's Office (2205)	RSA Law - Deputy Attorney General's Office - legal support services for the Civil Division. Program code: AG03501655.	472.5	188.5	190.8
5301 Inter-Agency Receipts	Law - Information and Project Support (2258)	RSA Law - Information and Project Support	186.0	0.0	0.0

Inter-Agency Services (1682)
Department of Law

Component: Office of the Attorney General (2162)

				FY2021 Actuals	FY2022 Management Plan	FY2023 Governor
Component Totals				92.3	7.1	7.1
With Department of Law				6.5	2.8	2.8
With Department of Administration				85.8	4.3	4.3
Object Class	Servicing Agency	Explanation	FY2021 Actuals	FY2022 Management Plan	FY2023 Governor	
3013	Inter-Agency Data Processing Operations Allocation	Law - Administrative Services (2164)	RSA Law, Information services, data processing investments and support.	1.9	0.1	0.1
3017	Inter-Agency Information Technology Non-Telecommunications	Admin - Department-wide	RSA Administration, Office of Information Technology computer services.	20.0	1.9	1.9
3018	Inter-Agency Information Technology Telecommunications	Admin - Department-wide	RSA Administration, Office of Information Technology telecommunications services.	2.6	1.1	1.1
3022	Inter-Agency Human Resources	Law - Administrative Services (2164)	RSA Law, Human Resources position.	4.6	2.7	2.7
3023	Inter-Agency Building Leases	Admin - Department-wide	Leased office space managed by General Services.	47.1	0.5	0.5
3026	Inter-Agency Insurance	Admin - Department-wide	RSA Administration, Risk Management.	15.3	0.1	0.1
3027	Inter-Agency Financial	Admin - Department-wide	RSA Administration, Finance Chargeback (IRIS).	0.8	0.7	0.7

Personal Services Expenditure Detail
Department of Law

Scenario: FY2023 Governor (18673)
Component: Office of the Attorney General (2162)
RDU: Administration and Support (280)

PCN	Job Class Title	Time Status	Retire Code	Barg Unit	Location	Salary Sched	Range / Step	Comp Months	Split / Count	Annual Salaries	COLA	Premium Pay	Annual Benefits	Total Costs	UGF Amount
03-0001	Commissioner	FT	A	XE	Anchorage	N00	0	12.0		169,709	0	0	82,010	251,719	251,719
03-0012	Executive Secretary 3	FT	A	XE	Anchorage	N00	16J	12.0		64,292	0	0	44,173	108,465	108,465
03-0310	Sp Asst Commr 2	FT	A	XE	Anchorage	N00	23K	12.0		106,256	0	0	59,796	166,052	119,557
03-0371	Sp Asst Commr 2	FT	A	XE	Anchorage	N00	23C / D	12.0		90,275	0	0	53,847	144,122	0
													Total Salary Costs:	430,532	
													Total COLA:	0	
													Total Premium Pay:	0	
													Total Benefits:	239,826	
													Total Pre-Vacancy:	670,358	
													Minus Vacancy Adjustment of 1.65%:	(11,058)	
													Total Post-Vacancy:	659,300	
													Plus Lump Sum Premium Pay:	0	
													Personal Services Line 100:	659,300	
Total Component Months:		48.0													

PCN Funding Sources:	Pre-Vacancy	Post-Vacancy	Percent
1004 General Fund Receipts	479,741	471,828	71.56%
1007 Interagency Receipts	190,617	187,472	28.44%
Total PCN Funding:	670,358	659,300	100.00%

Note: If a position is split, an asterisk (*) will appear in the Split/Count column. If the split position is also counted in the component, two asterisks (**) will appear in this column. [No valid job title] appearing in the Job Class Title indicates that the PCN has an invalid class code or invalid range for the class code effective date of this scenario.

Administration and Support

Office of the Attorney General

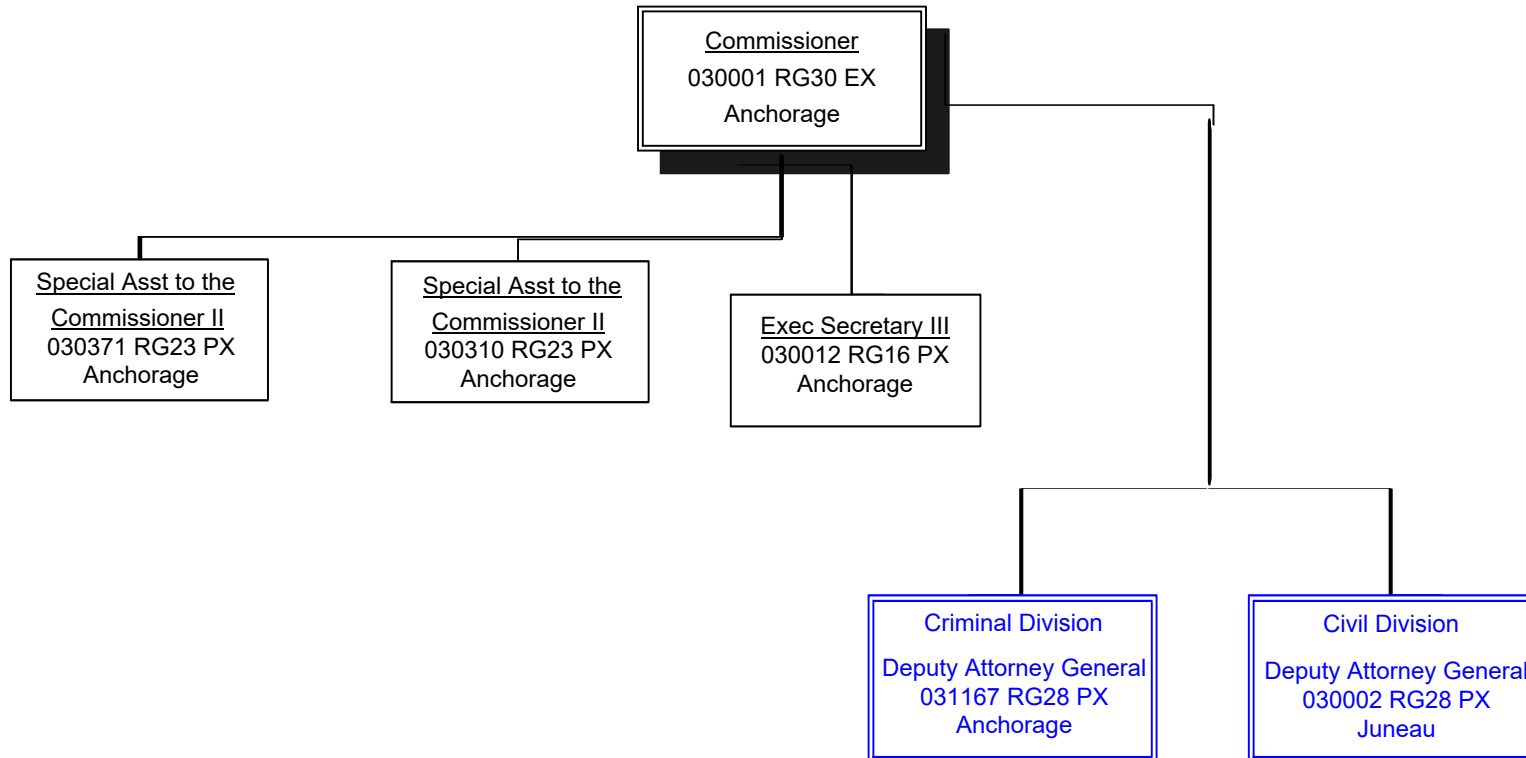

State of Alaska FY2023 Governor's Operating Budget

Department of Law Administrative Services Component Budget Summary

Component: Administrative Services**Contribution to Department's Mission**

The Administrative Services section provides budgeting, accounting, procurement, computing services and human resources to the Department of Law. These services enable the department to achieve its mission of providing legal services to state agencies and prosecuting crime.

Core Services

- Financial Management and Forecasting
- Budgeting
- Fiscal and Accounting
- Procurement and Contracts
- Information Services (in cooperation with the Department of Administration, Office of Information Technology)
- Timekeeping and Billing
- Cost Allocation
- Mail Services and Supply
- Human Resources

Major Component Accomplishments in 2021

The section provided financial, procurement, human resources, and information technology support to the department, including the following:

- Continued to revise, adapt, and implement department-level financial, procurement and human resource processes to further integrate administrative functions into the multi-faceted consolidation efforts within the Department of Administration.
- Building on existing resources, increased and enhanced mobile work platforms that allow prosecutors and support staff to operate successfully under widespread telework conditions and rural access challenges.
- Partnered with other agencies to increase the likelihood of a successful transition of the state's collections functions to an outside contractor under the shared services initiative in the Department of Administration.

Key Component Challenges

- Continuing to guide and support the transition of identified commodity services to various functional areas of the Department of Administration, including the Shared Services Division, Office of Procurement and Property Management, Division of Personnel and Labor Relations, and the Office of Information Technology.
- In concert with other stakeholders, working to identify business processes that will need to be altered or added as a result of further centralization of commodity services, such as procurement and human resource management, transitioning from individual executive branch agencies to the Department of Administration.
- Leveraging existing technologies to increase productivity and efficiency in an effort to make technology and telework resources perform better under the centralized Office of Information Technology framework.

Significant Changes in Results to be Delivered in FY2023

The state's shared services initiative will change the core portfolio of services provided by the Department of Law's (Law) Administrative Services component. As line-of-business financial functions transition to the Shared Services Division in the Department of Administration, Law's Administrative Services component will focus on delivering business intelligence products that allow for more resource-aware and increasingly strategic decision making by

department leadership. Law's Administrative Services component will further refine its role as a strategic partner as additional line-of-business functions, including day-to-day procurement and human resource tasks, are also consolidated under the Department of Administration. In addition, Law's Administrative Services component will work to maximize the efficiency and effectiveness of line-of-business services that are unique to the administrative challenges of civil litigation and prosecutorial work.

Statutory and Regulatory Authority

AS 44.23.020

Contact Information
<p>Contact: Amber LeBlanc, Director Phone: (907) 269-5100 E-mail: amber.leblanc@alaska.gov</p>

Administrative Services Personal Services Information				
Authorized Positions			Personal Services Costs	
	<u>FY2022</u> <u>Management</u> <u>Plan</u>	<u>FY2023</u> <u>Governor</u>		
Full-time	14	14	Annual Salaries	1,139,069
Part-time	0	0	COLA	4,264
Nonpermanent	0	0	Premium Pay	0
			Annual Benefits	693,413
			<i>Less 1.97% Vacancy Factor</i>	(36,246)
			Lump Sum Premium Pay	0
Totals	14	14	Total Personal Services	1,800,500

Position Classification Summary					
Job Class Title	Anchorage	Fairbanks	Juneau	Others	Total
Accountant 3	0	0	1	0	1
Accountant 5	0	0	1	0	1
Accounting Technician 1	0	0	1	0	1
Accounting Technician 2	0	0	2	0	2
Accounting Technician 3	0	0	2	0	2
Administrative Officer 2	0	0	1	0	1
Admn OPS Mgr 1	0	0	1	0	1
Analyst/Programmer 5	2	0	0	0	2
Budget Analyst 3	0	0	1	0	1
Human Resource Consultant 3	1	0	0	0	1
Procurement Specialist 1	0	0	1	0	1
Totals	3	0	11	0	14

Component Detail All Funds
Department of Law

Component: Administrative Services (2164)
RDU: Administration and Support (280)

Non-Formula Component

	FY2021 Actuals	FY2022 Conference Committee	FY2022 Authorized	FY2022 Management Plan	FY2023 Governor	FY2022 Management Plan vs FY2023 Governor	
71000 Personal Services	1,729.5	1,700.2	1,700.2	1,800.2	1,800.5	0.3	0.0%
72000 Travel	0.0	5.0	5.0	5.0	5.0	0.0	0.0%
73000 Services	470.3	1,566.9	1,566.9	1,466.9	1,416.9	-50.0	-3.4%
74000 Commodities	87.3	0.0	0.0	0.0	0.0	0.0	0.0%
75000 Capital Outlay	0.0	0.0	0.0	0.0	0.0	0.0	0.0%
77000 Grants, Benefits	0.0	0.0	0.0	0.0	0.0	0.0	0.0%
78000 Miscellaneous	0.0	0.0	0.0	0.0	0.0	0.0	0.0%
Totals	2,287.1	3,272.1	3,272.1	3,272.1	3,222.4	-49.7	-1.5%
Fund Sources:							
1004 Gen Fund (UGF)	1,109.1	1,323.6	1,323.6	1,323.6	1,282.9	-40.7	-3.1%
1007 I/A Rcpts (Other)	1,178.0	1,842.3	1,842.3	1,842.3	1,833.3	-9.0	-0.5%
1061 CIP Rcpts (Other)	0.0	106.2	106.2	106.2	106.2	0.0	0.0%
Unrestricted General (UGF)	1,109.1	1,323.6	1,323.6	1,323.6	1,282.9	-40.7	-3.1%
Designated General (DGF)	0.0	0.0	0.0	0.0	0.0	0.0	0.0%
Other Funds	1,178.0	1,948.5	1,948.5	1,948.5	1,939.5	-9.0	-0.5%
Federal Funds	0.0	0.0	0.0	0.0	0.0	0.0	0.0%
Positions:							
Permanent Full Time	15	13	13	14	14	0	0.0%
Permanent Part Time	0	0	0	0	0	0	0.0%
Non Permanent	0	0	0	0	0	0	0.0%

Change Record Detail - Multiple Scenarios with Descriptions
Department of Law

Component: Administrative Services (2164)
RDU: Administration and Support (280)

Scenario/Change Record Title	Trans Type	Totals	Personal Services	Travel	Services	Commodities	Capital Outlay	Grants, Benefits	Miscellaneous	Positions		NP
										PFT	PPT	
***** Changes From FY2022 Conference Committee To FY2022 Authorized *****												
FY2022 Conference Committee												
	ConfCom	3,272.1	1,700.2	5.0	1,566.9	0.0	0.0	0.0	0.0	13	0	0
1004 Gen Fund		1,323.6										
1007 I/A Rcpts		1,842.3										
1061 CIP Rcpts		106.2										
Subtotal		3,272.1	1,700.2	5.0	1,566.9	0.0	0.0	0.0	0.0	13	0	0
***** Changes From FY2022 Authorized To FY2022 Management Plan *****												
Transfer Authority from Services for Anticipated Personal Service Expenditures												
	LIT	0.0	100.0	0.0	-100.0	0.0	0.0	0.0	0.0	0	0	0
Transfer authority from the services line to the personal services line for anticipated personal services costs. The remaining services authority is anticipated to be sufficient to cover operating expenditures.												
Transfer Procurement Staff from Department of Administration for Procurement Consolidation Reversal												
	Atrin	0.0	0.0	0.0	0.0	0.0	0.0	0.0	0.0	1	0	0
Transfer procurement staff from the Department of Administration, Office of Procurement and Property Management to the Department of Law due to schedule adjustments to procurement consolidation.												
Subtotal		3,272.1	1,800.2	5.0	1,466.9	0.0	0.0	0.0	0.0	14	0	0
***** Changes From FY2022 Management Plan To FY2023 Governor *****												
FY2023 Supervisory Employees Health Insurance, SBS, and Risk Management Rate Changes												
	SalAdj	5.4	5.4	0.0	0.0	0.0	0.0	0.0	0.0	0	0	0
1004 Gen Fund		4.1										
1007 I/A Rcpts		1.3										
FY2023 Change Supervisory Employees (SS) - Health Insurance from \$1,555 to \$1,685; SBS and Risk Management Rates: \$5.4												
FY2023 Confidential Employees Association Health Insurance, SBS, and Risk Management Rate Changes												
	SalAdj	1.7	1.7	0.0	0.0	0.0	0.0	0.0	0.0	0	0	0
1007 I/A Rcpts		1.7										
FY2023 Change Confidential Employees Association CEA (KK) - Health Insurance from \$1,555 to \$1,685 per member; SBS, and Risk Management Rates: \$1.7												
FY2023 General Government Unit SBS and Risk Management Rate Changes												
	SalAdj	2.1	2.1	0.0	0.0	0.0	0.0	0.0	0.0	0	0	0
1004 Gen Fund		1.1										

Change Record Detail - Multiple Scenarios with Descriptions
Department of Law

Component: Administrative Services (2164)
RDU: Administration and Support (280)

Scenario/Change Record Title	Trans Type	Totals	Personal Services	Travel	Services	Commodities	Capital Outlay	Grants, Benefits	Miscellaneous	Positions		NP
										PFT	PPT	
1007 I/A Rcpts		1.0										
FY2023 Change General Government Unit (GG, GP, GY, GZ) - SBS, and Risk Management Rates: \$2.1												
FY2023 PERS Actuarial Rate Adjustment to 24.79% Ch9 SLA2021 (SB55)												
	SalAdj	-58.9	-58.9	0.0	0.0	0.0	0.0	0.0	0.0	0	0	0
1004 Gen Fund		-31.8										
1007 I/A Rcpts		-27.1										
Includes: FY2023 Adjustment for PERS ARM Board Approved Rate of 24.79% (from 30.11%): \$-58.9												
Realign PERS Rate Adjustment by Fund Source Ch9 SLA2021 (SB55)												
	FndChg	0.0	0.0	0.0	0.0	0.0	0.0	0.0	0.0	0	0	0
1004 Gen Fund		-14.1										
1007 I/A Rcpts		14.1										
Remove one-time UGF subsidy for rate agency assigned in SB55 fiscal note (Ch 9 SLA 2021).												
Transfer Authority to Personal Services for Anticipated Expenditures												
	LIT	0.0	50.0	0.0	-50.0	0.0	0.0	0.0	0.0	0	0	0
Transfer authority to the personal services line from the services line for anticipated costs. The remaining services authority is anticipated to be sufficient to cover operating expenditures.												
Totals		3,222.4	1,800.5	5.0	1,416.9	0.0	0.0	0.0	0.0	14	0	0

Line Item Detail (1676)
Department of Law
Travel

Component: Administrative Services (2164)

Line Number	Line Name		FY2021 Actuals	FY2022 Management Plan	FY2023 Governor
2000	Travel		0.0	5.0	5.0
Object Class	Servicing Agency	Explanation	FY2021 Actuals	FY2022 Management Plan	FY2023 Governor
2000 Travel Detail Totals			0.0	5.0	5.0
2000	In-State Employee Travel	Travel for attorneys to interview witnesses and attend court proceedings, as well as for necessary training for both attorneys and paraprofessionals. Includes travel for management purposes.	0.0	4.0	4.0
2002	Out of State Employee Travel	Travel costs and expenses for out-of-state travel for conferences, training, etc.	0.0	1.0	1.0

Line Item Detail (1676)
Department of Law
Services

Component: Administrative Services (2164)

Line Number	Line Name		FY2021 Actuals	FY2022 Management Plan	FY2023 Governor
3000	Services		470.3	1,466.9	1,416.9
Object Class	Servicing Agency	Explanation	FY2021 Actuals	FY2022 Management Plan	FY2023 Governor
3000 Services Detail Totals			470.3	1,466.9	1,416.9
3001	Financial Services	Bankcard service fees.	0.1	0.1	0.1
3003	Information Technology	Training, consulting and software licensing and maintenance. Annual maintenance fee for mission-critical information management systems.	115.5	166.6	146.6
3004	Telecommunications	Local telephone service, long distance charges and cellular phone services paid to third-party telephone utilities.	2.6	5.0	5.0
3006	Delivery Services	Freight, courier, postage, and transportation of trial exhibit materials.	3.5	5.0	5.0
3009	Structure/Infrastructure/Land	Rentals/leases - records and evidence storage.	3.2	4.2	4.2
3013	Inter-Agency Data Processing Operations Allocation	Law - Administrative Services (2164) RSA Law, Information services, data processing investments and support.	5.6	10.0	10.0
3017	Inter-Agency Information Technology Non-Telecommunications	Admin - Department-wide RSA Administration, Office of Information Technology computer services.	60.9	958.0	928.0
3018	Inter-Agency Information Technology Telecommunications	Admin - Department-wide RSA Administration, Office of Information Technology telecommunications services.	7.9	10.0	10.0
3021	Inter-Agency Mail	Admin - Department-wide RSA Administration, Central Mail.	3.4	5.0	5.0
3022	Inter-Agency Human Resources	Law - Administrative Services (2164) RSA Law, Human Resources position.	12.7	18.0	18.0
3023	Inter-Agency Building Leases	Admin - Department-wide Leased office space managed by	80.0	100.0	100.0

Line Item Detail (1676)
Department of Law
Services

Component: Administrative Services (2164)

Object Class		Servicing Agency	Explanation	FY2021 Actuals	FY2022 Management Plan	FY2023 Governor
			3000 Services Detail Totals	470.3	1,466.9	1,416.9
			General Services.			
3026	Inter-Agency Insurance	Admin - Department-wide	RSA Administration, Risk Management.	1.5	1.5	1.5
3027	Inter-Agency Financial	Admin - Department-wide	RSA Administration, Finance Chargeback (IRIS).	2.4	3.0	3.0
3028	Inter-Agency Americans with Disabilities Act Compliance	Admin - Department-wide	RSA Administration - Division of Personnel and Labor Relations, Americans with Disabilities Act.	0.1	0.5	0.5
3038	Inter-Agency Management/Consulting	Gov - Department-wide	RSA Law, Information services, project and management support.	170.9	180.0	180.0

Line Item Detail (1676)
Department of Law
Commodities

Component: Administrative Services (2164)

Line Number	Line Name		FY2021 Actuals	FY2022 Management Plan	FY2023 Governor
4000	Commodities		87.3	0.0	0.0
Object Class	Servicing Agency	Explanation	FY2021 Actuals	FY2022 Management Plan	FY2023 Governor
		4000 Commodities Detail Totals	87.3	0.0	0.0
4000	Business	Reference materials and subscriptions, including statutes, software applications, non-capital desktop refresh, and miscellaneous office supplies.	87.3	0.0	0.0

Revenue Detail (1681)
Department of Law

Component: Administrative Services (2164)

Revenue Type (OMB Fund Code) Revenue Source	Component	Comment	FY2021 Actuals	FY2022 Management Plan	FY2023 Governor
5007 I/A Rcpts (1007 I/A Rcpts)			1,178.0	1,842.3	1,833.3
5301 Inter-Agency Receipts	Law - Office of the Attorney General (2162)	Department-wide intra-agency funding for Human Resource Consultant position. Program code: AS03501666.	178.6	200.0	200.0
5301 Inter-Agency Receipts	Law - Office of the Attorney General (2162)	Department-wide intra-agency funding for information technology, fiscal and procurement positions and support. Program code: AS03502733.	199.4	792.3	783.3
5301 Inter-Agency Receipts	Law - Office of the Attorney General (2162)	Department-wide intra-agency funding for timekeeping and payroll administration and support. Program code: AS03502648.	800.0	850.0	850.0
5061 CIP Rcpts (1061 CIP Rcpts)			0.0	106.2	106.2
5351 Capital Improvement Project Inter-Agency		Personal services associated with administrative support and management of capital projects.	0.0	106.2	106.2

Inter-Agency Services (1682)
Department of Law

Component: Administrative Services (2164)

				FY2021 Actuals	FY2022 Management Plan	FY2023 Governor
Component Totals				345.4	1,286.0	1,256.0
With Department of Law				18.3	28.0	28.0
With Department of Administration				156.2	1,078.0	1,048.0
With Office of the Governor				170.9	180.0	180.0
Object Class	Servicing Agency	Explanation	FY2021 Actuals	FY2022 Management Plan	FY2023 Governor	
3013	Inter-Agency Data Processing Operations Allocation	Law - Administrative Services (2164)	RSA Law, Information services, data processing investments and support.	5.6	10.0	10.0
3017	Inter-Agency Information Technology Non-Telecommunications	Admin - Department-wide	RSA Administration, Office of Information Technology computer services.	60.9	958.0	928.0
3018	Inter-Agency Information Technology Telecommunications	Admin - Department-wide	RSA Administration, Office of Information Technology telecommunications services.	7.9	10.0	10.0
3021	Inter-Agency Mail	Admin - Department-wide	RSA Administration, Central Mail.	3.4	5.0	5.0
3022	Inter-Agency Human Resources	Law - Administrative Services (2164)	RSA Law, Human Resources position.	12.7	18.0	18.0
3023	Inter-Agency Building Leases	Admin - Department-wide	Leased office space managed by General Services.	80.0	100.0	100.0
3026	Inter-Agency Insurance	Admin - Department-wide	RSA Administration, Risk Management.	1.5	1.5	1.5
3027	Inter-Agency Financial	Admin - Department-wide	RSA Administration, Finance Chargeback (IRIS).	2.4	3.0	3.0
3028	Inter-Agency Americans with Disabilities Act Compliance	Admin - Department-wide	RSA Administration - Division of Personnel and Labor Relations, Americans with Disabilities Act.	0.1	0.5	0.5
3038	Inter-Agency Management/Consulting	Gov - Department-wide	RSA Law, Information services, project and management support.	170.9	180.0	180.0

Personal Services Expenditure Detail
Department of Law

Scenario: FY2023 Governor (18673)
Component: Administrative Services (2164)
RDU: Administration and Support (280)

PCN	Job Class Title	Time Status	Retire Code	Barg Unit	Location	Salary Sched	Range / Step	Comp Months	Split / Count	Annual Salaries	COLA	Premium Pay	Annual Benefits	Total Costs	UGF Amount
03-0011	Admn OPS Mgr 1	FT	A	SS	Juneau	205	22F	12.0		106,725	1,465	0	60,115	168,305	126,229
03-0038	Accountant 5	FT	A	SS	Juneau	205	22J / K	12.0		112,297	1,541	0	62,189	176,027	132,020
03-0088	Accountant 3	FT	A	GP	Juneau	205	18J	12.0		80,652	0	0	48,808	129,460	97,095
03-0135	Accounting Technician 3	FT	A	GP	Juneau	99	16O	12.0		83,168	0	0	49,745	132,913	0
03-0136	Accounting Technician 2	FT	A	GP	Juneau	205	14L / M	12.0		66,180	0	0	43,420	109,600	109,600
03-0144	Accounting Technician 1	FT	A	GP	Juneau	205	12A / B	12.0		42,705	0	0	34,680	77,385	77,385
03-0240	Analyst/Programmer 5	FT	A	GP	Anchorage	200	22E / F	12.0		91,884	0	0	52,990	144,874	36,219
03-0249	Procurement Specialist 1	FT	A	GP	Juneau	205	14M	12.0		67,431	0	0	43,886	111,317	111,317
03-0261	Accounting Technician 2	FT	A	GP	Juneau	205	14G / J	12.0		59,308	0	0	40,862	100,170	40,068
03-0323	Analyst/Programmer 5	FT	A	GP	Anchorage	99	22M / M	12.0		108,238	0	0	59,078	167,316	0
03-0340	Accounting Technician 3	FT	A	GP	Juneau	205	16D / E	12.0		61,664	0	0	41,739	103,403	0
03-0361	Budget Analyst 3	FT	A	GP	Juneau	205	21G / J	12.0		97,676	0	0	55,146	152,822	152,822
03-6527	Administrative Officer 2	FT	A	SS	Juneau	205	19L / M	12.0		91,638	1,258	0	54,498	147,394	110,546
06-6158	Human Resource Consultant 3	FT	A	KK	Anchorage	200	19A / B	12.0		69,503	0	0	46,257	115,760	0

	Total Positions	New	Deleted	Total Salary Costs:	Total COLA:	Total Premium Pay:	Total Benefits:
				1,139,069	4,264	0	693,413
Full Time Positions:	14	0	0				
Part Time Positions:	0	0	0				
Non Permanent Positions:	0	0	0				
Positions in Component:	14	0	0				
				Total Pre-Vacancy:	1,836,746		
				Minus Vacancy Adjustment of 1.97%:	(36,246)		
				Total Post-Vacancy:	1,800,500		
				Plus Lump Sum Premium Pay:	0		
				Personal Services Line 100:	1,800,500		

PCN Funding Sources:	Pre-Vacancy	Post-Vacancy	Percent
1004 General Fund Receipts	993,300	973,698	54.08%
1007 Interagency Receipts	843,446	826,802	45.92%
Total PCN Funding:	1,836,746	1,800,500	100.00%

Note: If a position is split, an asterisk (*) will appear in the Split/Count column. If the split position is also counted in the component, two asterisks (**) will appear in this column. [No valid job title] appearing in the Job Class Title indicates that the PCN has an invalid class code or invalid range for the class code effective date of this scenario.

Administration and Support Administrative Services

Positions shown below have been transferred to the Office of Information Technology in the Department of Administration, effective 10/01/2017. PCN 03-0257 was transferred during FY2017.

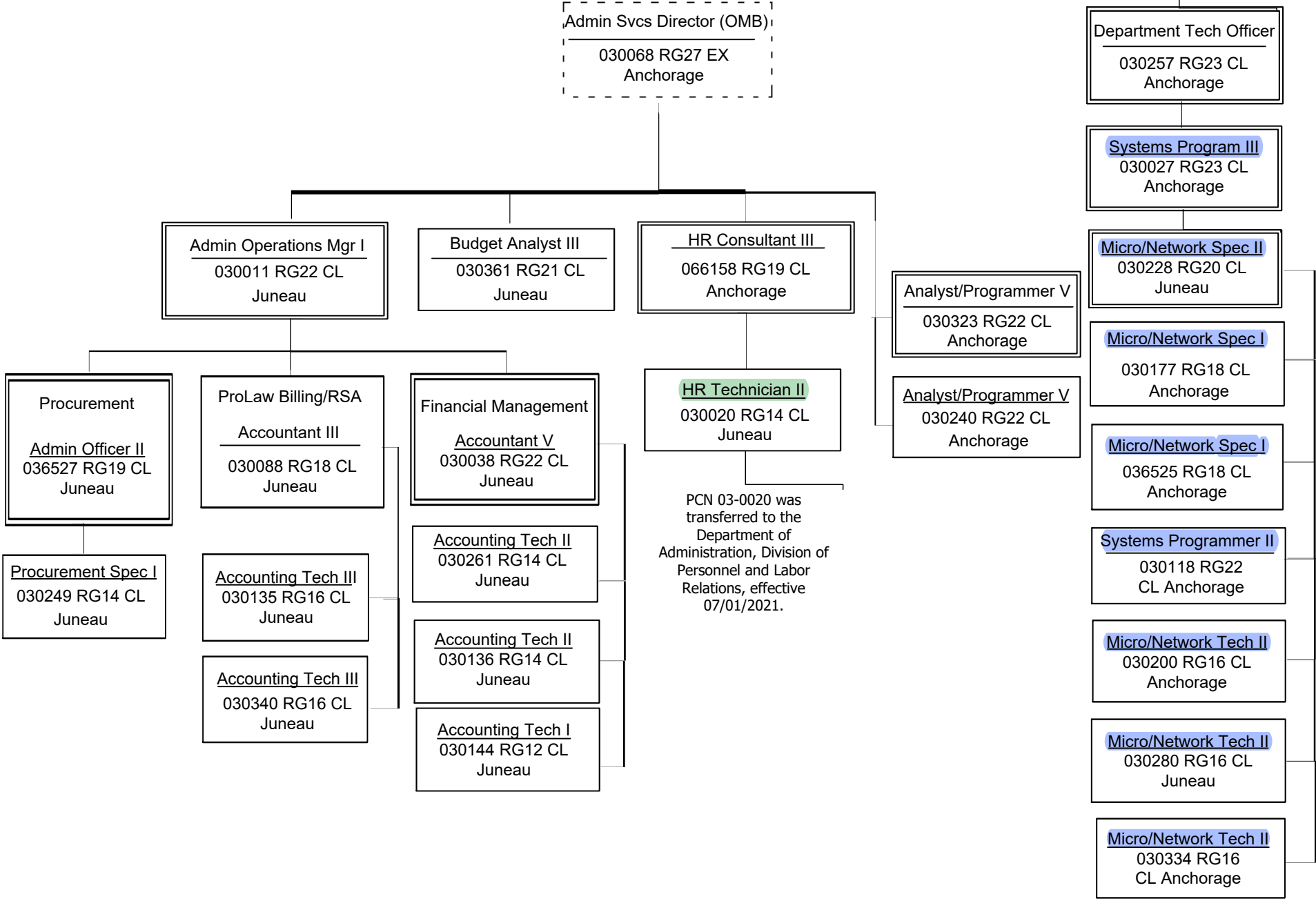

State of Alaska FY2023 Governor's Operating Budget

Department of Law Department of Law State Facilities Rent Component Budget Summary

Component: Department of Law State Facilities Rent

Contribution to Department's Mission

No mission statement.

Major Component Accomplishments in 2021

No major accomplishments.

Key Component Challenges

No key component challenges.

Significant Changes in Results to be Delivered in FY2023

No changes in results delivered.

Statutory and Regulatory Authority

No statutes and regulations.

Contact Information

Contact: Amber LeBlanc, Director
Phone: (907) 260-5100
E-mail: amber.leblanc@alaska.gov

Component Detail All Funds
Department of Law

Component: Department of Law State Facilities Rent (2852)
RDU: Administration and Support (280)

Non-Formula Component

	FY2021 Actuals	FY2022 Conference Committee	FY2022 Authorized	FY2022 Management Plan	FY2023 Governor	FY2022 Management Plan vs FY2023 Governor	
71000 Personal Services	0.0	0.0	0.0	0.0	0.0	0.0	0.0%
72000 Travel	0.0	0.0	0.0	0.0	0.0	0.0	0.0%
73000 Services	846.3	846.3	846.3	846.3	846.3	0.0	0.0%
74000 Commodities	0.0	0.0	0.0	0.0	0.0	0.0	0.0%
75000 Capital Outlay	0.0	0.0	0.0	0.0	0.0	0.0	0.0%
77000 Grants, Benefits	0.0	0.0	0.0	0.0	0.0	0.0	0.0%
78000 Miscellaneous	0.0	0.0	0.0	0.0	0.0	0.0	0.0%
Totals	846.3	846.3	846.3	846.3	846.3	0.0	0.0%
Fund Sources:							
1004 Gen Fund (UGF)	846.3	846.3	846.3	846.3	846.3	0.0	0.0%
Unrestricted General (UGF)	846.3	846.3	846.3	846.3	846.3	0.0	0.0%
Designated General (DGF)	0.0	0.0	0.0	0.0	0.0	0.0	0.0%
Other Funds	0.0	0.0	0.0	0.0	0.0	0.0	0.0%
Federal Funds	0.0	0.0	0.0	0.0	0.0	0.0	0.0%
Positions:							
Permanent Full Time	0	0	0	0	0	0	0.0%
Permanent Part Time	0	0	0	0	0	0	0.0%
Non Permanent	0	0	0	0	0	0	0.0%

Change Record Detail - Multiple Scenarios with Descriptions
Department of Law

Component: Department of Law State Facilities Rent (2852)
RDU: Administration and Support (280)

Scenario/Change Record Title	Trans Type	Totals	Personal Services	Travel	Services	Commodities	Capital Outlay	Grants, Benefits	Miscellaneous	Positions		NP
										PFT	PPT	
***** Changes From FY2022 Conference Committee To FY2022 Authorized *****												
FY2022 Conference Committee	ConfCom	846.3	0.0	0.0	846.3	0.0	0.0	0.0	0.0	0	0	0
1004 Gen Fund		846.3										
Subtotal		846.3	0.0	0.0	846.3	0.0	0.0	0.0	0.0	0	0	0
***** Changes From FY2022 Management Plan To FY2023 Governor *****												
Totals		846.3	0.0	0.0	846.3	0.0	0.0	0.0	0.0	0	0	0

Line Item Detail (1676)
Department of Law
Services

Component: Department of Law State Facilities Rent (2852)

Line Number	Line Name			FY2021 Actuals	FY2022 Management Plan	FY2023 Governor
3000	Services			846.3	846.3	846.3
Object Class		Servicing Agency	Explanation	FY2021 Actuals	FY2022 Management Plan	FY2023 Governor
3000 Services Detail Totals				846.3	846.3	846.3
3023	Inter-Agency Building Leases	Admin - Department-wide	Leased office space managed by General Services.	846.3	846.3	846.3

Inter-Agency Services (1682)
Department of Law

Component: Department of Law State Facilities Rent (2852)

				FY2021 Actuals	FY2022 Management Plan	FY2023 Governor
Component Totals				846.3	846.3	846.3
With Department of Administration				846.3	846.3	846.3
Object Class	Servicing Agency	Explanation		FY2021 Actuals	FY2022 Management Plan	FY2023 Governor
3023 Inter-Agency Building Leases	Admin - Department-wide	Leased office space managed by General Services.		846.3	846.3	846.3

State of Alaska
FY2023 Governor's Operating Budget

Department of Law
Legal Contracts Janus v AFSCME Decision
RDU/Component Budget Summary

RDU/Component: Legal Contracts Janus v AFSCME Decision

Contribution to Department's Mission

No mission statement.

Major Component Accomplishments in 2021

No major accomplishments.

Key Component Challenges

No key component challenges.

Significant Changes in Results to be Delivered in FY2023

No changes in results delivered.

Statutory and Regulatory Authority

No statutes and regulations.

Contact Information

Contact: Unknown, Unknown
Phone: () -
E-mail: Unknown

Component Detail All Funds
Department of Law

Component: Legal Contracts Janus v AFSCME Decision (3286)
RDU: Legal Contracts Janus v AFSCME Decision (708)

Non-Formula Component

	FY2021 Actuals	FY2022 Conference Committee	FY2022 Authorized	FY2022 Management Plan	FY2023 Governor	FY2022 Management Plan vs FY2023 Governor
71000 Personal Services	0.0	0.0	0.0	0.0	0.0	0.0 0.0%
72000 Travel	0.0	0.0	0.0	0.0	0.0	0.0 0.0%
73000 Services	0.0	20.0	0.0	0.0	0.0	0.0 0.0%
74000 Commodities	0.0	0.0	0.0	0.0	0.0	0.0 0.0%
75000 Capital Outlay	0.0	0.0	0.0	0.0	0.0	0.0 0.0%
77000 Grants, Benefits	0.0	0.0	0.0	0.0	0.0	0.0 0.0%
78000 Miscellaneous	0.0	0.0	0.0	0.0	0.0	0.0 0.0%
Totals	0.0	20.0	0.0	0.0	0.0	0.0 0.0%
Fund Sources:						
1004 Gen Fund (UGF)	0.0	20.0	0.0	0.0	0.0	0.0 0.0%
Unrestricted General (UGF)	0.0	20.0	0.0	0.0	0.0	0.0 0.0%
Designated General (DGF)	0.0	0.0	0.0	0.0	0.0	0.0 0.0%
Other Funds	0.0	0.0	0.0	0.0	0.0	0.0 0.0%
Federal Funds	0.0	0.0	0.0	0.0	0.0	0.0 0.0%
Positions:						
Permanent Full Time	0	0	0	0	0	0 0.0%
Permanent Part Time	0	0	0	0	0	0 0.0%
Non Permanent	0	0	0	0	0	0 0.0%

Change Record Detail - Multiple Scenarios with Descriptions
Department of Law

Component: Legal Contracts Janus v AFSCME Decision (3286)

RDU: Legal Contracts Janus v AFSCME Decision (708)

Scenario/Change Record Title	Trans Type	Totals	Personal Services	Travel	Services	Commodities	Capital Outlay	Grants, Benefits	Miscellaneous	Positions		NP
										PFT	PPT	
***** Changes From FY2022 Conference Committee To FY2022 Authorized *****												
FY2022 Conference Committee												
	ConfCom	20.0	0.0	0.0	20.0	0.0	0.0	0.0	0.0	0	0	0
1004 Gen Fund		20.0										
Legal Contracts Relating to Interpretation of Janus v. AFSCME Decision Sec1 Ch1 SSSLA2021 (HB69)												
	Veto	-20.0	0.0	0.0	-20.0	0.0	0.0	0.0	0.0	0	0	0
1004 Gen Fund		-20.0										
This veto eliminates a new appropriation: Legal Contracts Relating to Interpretation of Janus v AFSCME Decision and funding. This was an addition by the Legislature and was not requested by the Department of Law.												
Subtotal		0.0	0.0	0.0	0.0	0.0	0.0	0.0	0.0	0	0	0
***** Changes From FY2022 Management Plan To FY2023 Governor *****												
Totals		0.0	0.0	0.0	0.0	0.0	0.0	0.0	0.0	0	0	0