

State of Alaska FY2024 Governor's Operating Budget

**Department of Administration
Office of Public Advocacy
Component Budget Summary**

Component: Office of Public Advocacy

Contribution to Department's Mission

Provide legal advocacy and guardian services to vulnerable Alaskans.

Results

(Additional performance information is available on the web at <https://omb.alaska.gov/results>.)

Core Services

- Guardianship Services.
- Guardian Ad Litem Services.
- Elder Fraud Litigation

Measures by Core Service

(Additional performance information is available on the web at <https://omb.alaska.gov/results>.)

1. Guardianship Services.

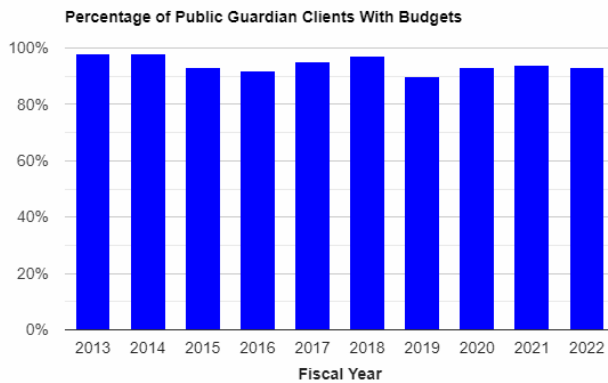
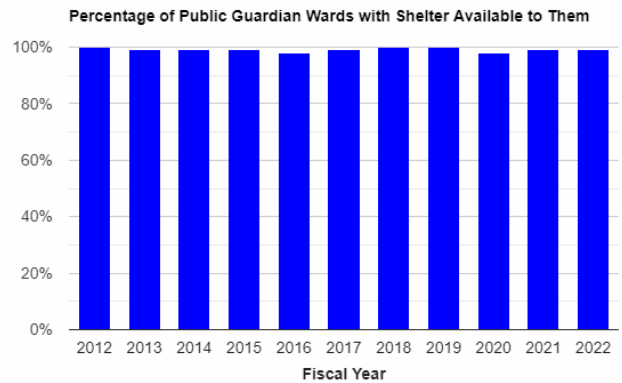

2. Guardian Ad Litem Services.

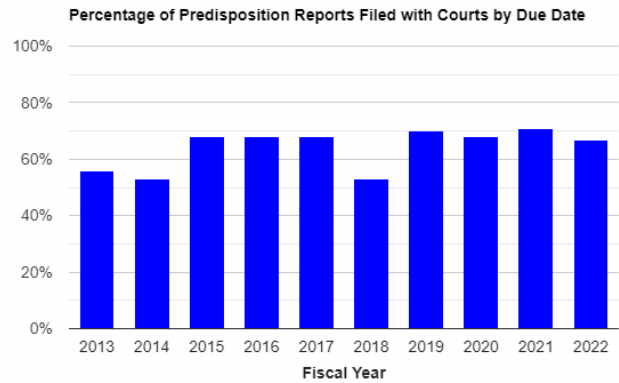
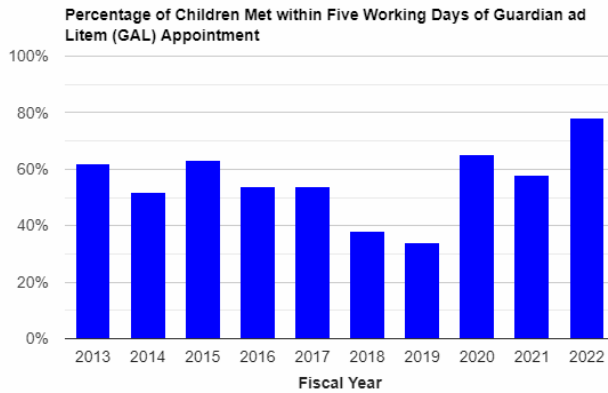

3. Elder Fraud Litigation

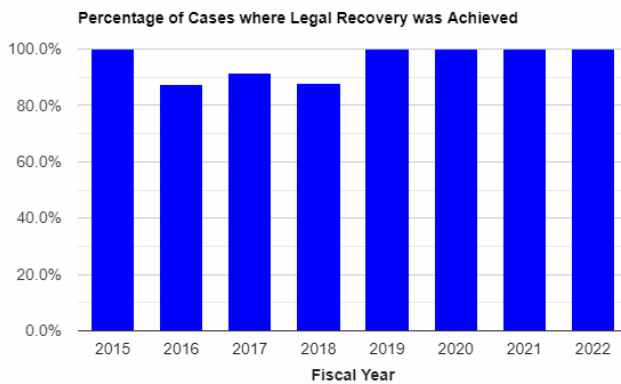

Major Component Accomplishments in 2022

- Minimized attrition during a pandemic with a tight labor market and large trial case backlog.
- Drastically increased the number of class A and unclassified felony cases that were kept in-house, as opposed to being contracted to outside attorneys, to reduce criminal contractor costs.
- Completed the reorganization of the public guardian section to increase efficiency.
- Actively and successfully continued to challenge improper appointments by the Court.

Key Component Challenges

Growing Caseload – Due to the inherently unpredictable nature of the multiple types of caseloads, it is a significant challenge to maintain and provide core services to clients as efficiently as possible. Office of Public Advocacy (OPA) is primarily a “down flow” agency in that it reacts to the actions of the other state agencies and systems (i.e., the Public Defender Agency, the Office of Children’s Services, Adult Protective Services, the Attorney General Human Services Section, the District Attorney’s Office, the Court System, and other public and private entities). As a result, the unpredictability of caseload assignments makes it difficult to accurately forecast caseload increases and costs for upcoming budget years.

Criminal trial cases – OPA experienced a substantial increase in criminal trial caseload due to the COVID case backlog. This, combined with various recently passed crime bills, will continue to strain the agency. OPA is working to keep as many cases in-house as possible, but volume of cases necessitates use of private contract attorneys due to conflicts of interest and case overloads. OPA cannot legally refuse cases.

Increase in Juvenile Delinquency cases – There has been an unexpected increase in juvenile delinquency cases over the last several years. OPA’s delinquency cases more than doubled between FY2020 and FY2021 and then

almost doubled again between FY2021 and FY2022 – overall quadrupling since FY2019.

- OPAs Juvenile delinquency case numbers are: FY2019 – 35; FY2020 – 40; FY2021 – 87; FY2022 – 148
- The increase from 35 cases to 148 cases is a 323% increase.
- The increase since FY2020, 40 cases to 148 cases, is a 270% increase.

If this trend remains consistent, or increases, it will outstrip the agency's ability to place cases within existing resources.

Significant Caseload Increases for Public Guardians – The Public Guardian section continued to experience significant caseload increases. Since the start of 2013, the caseload has steadily increased totaling an additional 285 clients annually. Currently, the agency is approaching 1,800 wards. Many Guardians still carry caseloads more than 80 cases with the senior Guardians carrying caseloads hovering at 100 wards. Moreover, as the Alaskan population ages (silver tidal wave), the number of wards assigned to the agency will expand every year for the foreseeable future. The COVID Federal Health Emergency Declaration is being lifted mid-January 2023. This declaration drastically reduced the need for renewal applications to be filed as benefit for wards expired. OPA eligibility technicians will soon be tasked with filing an additional 290 benefit renewal applications on top of their current workload.

Thus, increased ward/case numbers will remain a challenge for FY2024. To help address this challenge, OPA has reorganized its Public Guardian section by creating a multi-tiered single job class while simultaneously restructuring how the section is supervised. This growth is also straining OPA criminal and CINA attorneys who are also required to represent any person who is potentially being placed under a guardianship. OPA has requested additional funding to add Public Guardian positions in FY2024 to address this growing need.

Excessive Burden on Guardians Ad Litem (GALs) – Increased appointments from the court system may be related to budgetary concerns. For example, the court system recently cut its custody investigator program. OPA is concerned that GALs may be improperly substituted by the court to fill this role. OPA has continued to see increased appointments of GALs in civil non-CINA cases into FY2023.

Significant Changes in Results to be Delivered in FY2024

Cost Efficiency Matters – OPA has strict cost control procedures in place requiring Director or Deputy approval for virtually all expenditures. All expenditures whether for supplies, investigators or expert witnesses must be clearly justified to be approved. OPA closely reviews all appointments received and works to limit the number of cases sent to private contractors which in turn helps stabilize the budget and reduce overall expenses. OPA actively files motions to vacate inappropriate appointments sent by the Court.

Child Advocacy Caseloads – The agency will continue entering appropriate partnerships with community groups to expand the National Court Appointed Special Advocate (CASA) program and specifically target Alaska Native CASA volunteers for recruitment to continue to assist the GAL with their increased caseloads. OPA is currently in discussions with several tribes to forge a collaborative arrangement and recruit CASA volunteers for both state and tribal courts.

Should the Office of Child Services (OCS) increase its filings, then GAL caseloads will necessarily increase. OPA is also concerned with improper GAL appointments by the court, particularly in civil custody cases as discussed above. Any appointments outside of OPAs enabling statute must be challenged to prevent straining already limited resources. It is challenging to predict caseloads for FY2024 as OCS and Attorney General (AG) staffing challenges continue to impact how resource intensive CINA litigation will be in the near future. Some jurisdictions have become exceedingly litigious and adversarial while others are able to resolve cases in a timelier manner.

Criminal Defense Caseloads – In an effort to address the COVID case backlog, the court system has scheduled numerous jury trials well into FY2024. The increase in trial cases hampers OPA's small section's ability to meet the obligations of current and incoming cases. OPA will continue to strive to meet its constitutional obligations and will continue to work diligently with the Department of Administration Commissioner and Deputy Commissioner to face these challenges and find creative solutions whenever possible.

Statutory and Regulatory Authority

AS 44.21.400 et seq. Office of Public Advocacy
2 AAC 60 et seq. Office of Public Advocacy

Contact Information
<p>Contact: James Stinson, Director Phone: (907) 269-3500 E-mail: james.stinson@alaska.gov</p>

Office of Public Advocacy Personal Services Information					
Authorized Positions			Personal Services Costs		
	FY2023 Management Plan	FY2024 Governor			
Full-time	162	167	Annual Salaries		17,068,904
Part-time	2	2	COLA		186,181
Nonpermanent	12	12	Premium Pay		20,267
			Annual Benefits		9,713,100
			Less 5.73% Vacancy Factor		(1,546,552)
			Lump Sum Premium Pay		0
Totals	176	181	Total Personal Services		25,441,900

Position Classification Summary					
Job Class Title	Anchorage	Fairbanks	Juneau	Others	Total
Accountant 4	1	0	0	0	1
Accounting Technician 1	2	0	0	0	2
Accounting Technician 3	2	0	0	0	2
Administrative Assistant 1	1	0	0	0	1
Administrative Officer 1	1	0	0	0	1
Associate Attorney 1	1	0	0	0	1
Associate Attorney 2	13	3	2	4	22
Attorney 1	1	0	0	0	1
Attorney 2	1	1	0	2	4
Attorney 3	7	0	0	2	9
Attorney 4	22	5	1	5	33
Attorney 5	9	3	2	4	18
Attorney 6	2	0	0	0	2
Division Director - Px	1	0	0	0	1
Eligibility Technician 2	2	0	0	0	2
Investigator 2	1	1	0	0	2
Investigator 3	4	1	1	1	7
Law Office Assistant 1	3	1	1	0	5
Law Office Assistant 2	6	2	1	3	12
Law Office Assistant 3	1	0	0	0	1
Office Assistant 1	1	0	0	2	3
Office Assistant 2	2	0	0	0	2
Paralegal 1	6	0	1	1	8
Paralegal 2	4	3	0	3	10
Program Coordinator 1	1	0	0	0	1
Project Assistant	1	1	1	1	4
Public Guardian 1	2	0	0	0	2
Public Guardian 2	13	2	2	2	19
Public Guardian 3	3	0	0	1	4
Public Guardian 4	1	0	0	0	1
Totals	115	23	12	31	181

Component Detail All Funds
Department of Administration

Component: Office of Public Advocacy (43)
RDU: Legal and Advocacy Services (11)

Non-Formula Component

	FY2022 Actuals	FY2023 Conference Committee	FY2023 Authorized	FY2023 Management Plan	FY2024 Governor	FY2023 Management Plan vs FY2024 Governor	
71000 Personal Services	22,389.8	22,828.6	24,159.2	24,367.9	25,441.9	1,074.0	4.4%
72000 Travel	155.6	329.8	329.8	329.8	337.2	7.4	2.2%
73000 Services	9,456.4	8,402.5	7,647.3	7,438.6	8,783.4	1,344.8	18.1%
74000 Commodities	210.1	232.4	232.4	232.4	239.0	6.6	2.8%
75000 Capital Outlay	0.0	0.0	0.0	0.0	0.0	0.0	0.0%
77000 Grants, Benefits	0.0	0.0	0.0	0.0	0.0	0.0	0.0%
78000 Miscellaneous	0.0	0.0	0.0	0.0	0.0	0.0	0.0%
Totals	32,211.9	31,793.3	32,368.7	32,368.7	34,801.5	2,432.8	7.5%
Fund Sources:							
1002 Fed Rcpts (Fed)	229.5	264.0	264.0	264.0	264.0	0.0	0.0%
1003 G/F Match (UGF)	250.0	250.0	250.0	250.0	250.0	0.0	0.0%
1004 Gen Fund (UGF)	6,755.4	16,645.5	17,013.8	17,013.8	29,267.9	12,254.1	72.0%
1005 GF/Prgm (DGF)	1,935.9	1,935.9	1,935.9	1,935.9	1,935.9	0.0	0.0%
1007 I/A Rcpts (Other)	806.4	597.9	599.3	599.3	613.1	13.8	2.3%
1037 GF/MH (UGF)	2,044.0	2,009.0	2,214.7	2,214.7	2,244.3	29.6	1.3%
1092 MHTAAR (Other)	95.6	91.0	91.0	91.0	226.3	135.3	148.7%
1108 Stat Desig (Other)	95.3	0.0	0.0	0.0	0.0	0.0	0.0%
1271 ARPA Rev R (UGF)	19,999.8	10,000.0	10,000.0	10,000.0	0.0	-10,000.0	-100.0%
Unrestricted General (UGF)	29,049.2	28,904.5	29,478.5	29,478.5	31,762.2	2,283.7	7.7%
Designated General (DGF)	1,935.9	1,935.9	1,935.9	1,935.9	1,935.9	0.0	0.0%
Other Funds	997.3	688.9	690.3	690.3	839.4	149.1	21.6%
Federal Funds	229.5	264.0	264.0	264.0	264.0	0.0	0.0%
Positions:							
Permanent Full Time	162	162	162	162	167	5	3.1%
Permanent Part Time	2	2	2	2	2	0	0.0%
Non Permanent	12	12	12	12	12	0	0.0%

Change Record Detail - Multiple Scenarios with Descriptions
Department of Administration

Component: Office of Public Advocacy (43)
RDU: Legal and Advocacy Services (11)

Scenario/Change Record Title	Trans Type	Totals	Personal Services	Travel	Services	Commodities	Capital Outlay	Grants, Benefits	Miscellaneous	Positions		NP
										PFT	PPT	
***** Changes From FY2023 Conference Committee To FY2023 Authorized *****												
FY2023 Conference Committee												
ConfCom		31,793.3	22,828.6	329.8	8,402.5	232.4	0.0	0.0	0.0	162	2	12
1002 Fed Rcpts		264.0										
1003 G/F Match		250.0										
1004 Gen Fund		16,645.5										
1005 GF/Prgm		1,935.9										
1007 I/A Rcpts		597.9										
1037 GF/MH		2,009.0										
1092 MHTAAR		91.0										
1271 ARPA Rev R		10,000.0										
Align Authority for Unallocated Rates Adjustments												
Unalloc		99.2	0.0	0.0	99.2	0.0	0.0	0.0	0.0	0	0	0
1004 Gen Fund		99.2										
In FY2023 unallocated rates adjustments were appropriated to the Department of Administration to provide funding for the following rates adjustments:												
FY2023 Administrative Systems Rate Adjusted Base Change \$-43.9												
FY2023 Administrative Systems Upgrade Ongoing Costs Increases \$96.5												
FY2023 Human Resources Rate Adjusted Base Change \$-10.7												
FY2023 Human Resources Rate AspireAlaska \$35.7												
FY2023 Office of Information Technology Core Services Rate Adjusted Base Rate Change \$37.5												
FY2023 Office of Information Technology Core Services Rate Infrastructure Upkeep Increase \$107.0												
FY2023 Office of Information Technology Core Services Rate Software Increases \$238.5												
FY2023 Office of Information Technology Mainframe Increases \$8.1												
FY2023 Office of Information Technology Other Non-Core Adjusted Base \$201.2												
FY2023 Travel and Accounts Payable Rate Adjusted Base Change \$-61.3												
This is the distribution of those unallocated rates to the divisions within the Department.												
Retention Bonuses												
Veto		-968.4	-968.4	0.0	0.0	0.0	0.0	0.0	0.0	0	0	0
1004 Gen Fund		-968.4										
Court System Provide Visitors & Experts Ch21 SLA2022 (HB155) (Sec2 Ch11 SLA2022 P46 L27 (HB281))												
FisNot		-854.4	0.0	0.0	-854.4	0.0	0.0	0.0	0.0	0	0	0
1004 Gen Fund		-854.4										
FY2023 15% Attorney & Administrative Law Judge COLA												
SalAdj		1,650.2	1,650.2	0.0	0.0	0.0	0.0	0.0	0.0	0	0	0
1004 Gen Fund		1,499.5										

Change Record Detail - Multiple Scenarios with Descriptions
Department of Administration

Component: Office of Public Advocacy (43)
RDU: Legal and Advocacy Services (11)

Scenario/Change Record Title	Trans Type	Totals	Personal Services	Travel	Services	Commodities	Capital Outlay	Grants, Benefits	Miscellaneous	Positions		
										PFT	PPT	NP
1037 GF/MH		150.7										
FY2023 15% Attorney & Administrative Law Judge COLA: \$1,612.3												
FY2023 Exempt 5% COLA												
	SalAdj	648.8	648.8	0.0	0.0	0.0	0.0	0.0	0.0	0	0	0
1004 Gen Fund		592.4										
1007 I/A Rcpts		1.4										
1037 GF/MH		55.0										
FY2023 Exempt 5% COLA: \$648.8												
Subtotal		32,368.7	24,159.2	329.8	7,647.3	232.4	0.0	0.0	0.0	162	2	12
***** Changes From FY2023 Authorized To FY2023 Management Plan *****												
Align Authority with Anticipated Personal Services Costs												
	LIT	0.0	208.7	0.0	-208.7	0.0	0.0	0.0	0.0	0	0	0
Transfer authority from services to cover anticipated personal services costs. The remaining services authority is sufficient to cover anticipated expenditures.												
Subtotal		32,368.7	24,367.9	329.8	7,438.6	232.4	0.0	0.0	0.0	162	2	12
***** Changes From FY2023 Management Plan To FY2024 Governor *****												
Correct FY2023 GGU COLA & HI Increase												
	FndChg	0.0	0.0	0.0	0.0	0.0	0.0	0.0	0.0	0	0	0
1037 GF/MH		2.4										
1092 MHTAAR		-2.4										
FY2023 GGU 3% COLA: \$194.8												
FY2023 GGU \$12.50 HI Increase: \$11.0												
Reverse Restore One-Time Fund Source Change to Utilize ARPA Revenue Replacement												
	OTI	0.0	0.0	0.0	0.0	0.0	0.0	0.0	0.0	0	0	0
1004 Gen Fund		10,000.0										
1271 ARPA Rev R		-10,000.0										
Reverse MH Trust: Public Guardian Position												
	OTI	-91.5	-89.5	-2.0	0.0	0.0	0.0	0.0	0.0	0	0	0
1092 MHTAAR		-91.5										

Change Record Detail - Multiple Scenarios with Descriptions
Department of Administration

Component: Office of Public Advocacy (43)
RDU: Legal and Advocacy Services (11)

Scenario/Change Record Title	Trans Type	Totals	Personal Services	Travel	Services	Commodities	Capital Outlay	Grants, Benefits	Miscellaneous	Positions		
										PFT	PPT	NP

Support a public guardian position in the Office of Public Advocacy located in Anchorage and serving the Western Alaska region including Bethel, Dillingham, Naknek, and surrounding communities. This position supports the Office of Public Advocacy's strategic plan to bring down current public guardian caseloads from approximately 100 cases per public guardian to the recommended national maximum of 40 cases per public guardian, resulting in improved services, supports, and overall management of Trust beneficiaries.

Public guardians serve adult Trust beneficiaries found to be incapacitated by the Superior Court. Public guardians are required to maintain benefits, manage finances, make medical decisions, and ensure suitable housing for each Trust beneficiary. Assisting Trust beneficiaries with these needs improves public protection and State resource management by giving them the ability to live safely in their communities rather than in State hospitals or even correctional institutions.

HB325 Domestic Violence/Sexual Offenses/Consent Fiscal Note

	FisNot	1,964.2	627.5	2.4	1,327.7	6.6	0.0	0.0	0.0	4	0	0
1004 Gen Fund		1,964.2										

This provides authority required to increase services as requested in an unsuccessful fiscal note for SLA 2022 House Bill 325. Effective January 1, 2023, HB 325 changes the definition of consent as it relates to sex assault allegations, which will have significant impacts on the way sexual assault cases are litigated and will require additional positions for the Legal Advocacy Services agencies to complete the workload resulting from these changes.

Fiscal notes were completed by the Department of Administration (DOA) for the original legislation in HB5; however, that bill was rolled into HB 325 in the final hours of the legislative session. DOA completed updated fiscal notes for HB 325; however, they were not properly attached to the bill prior to its passage.

These legal agencies are already understaffed and experiencing difficulty with recruitment and retention due to the high stress environment. The increase in serious felony level case filings continues while agency attorneys and staff face a mounting backlog of cases post trial suspensions because of the pandemic. This legislation will result in a significant increase in sexual assault cases filed and increase litigation in these cases. These positions are needed to maintain pace with the constitutionally mandated annual caseload activity.

Full-time Law Office Assistant 1/2 flex (02-#152), range 11/13, located in Palmer
 Full-time Law Office Assistant 1/2 flex (02-#153), range 11/13, located in Fairbanks
 Full-time Investigator 1/2/3 flex (02-#154), range 14/16/18, located in Fairbanks
 Full-time Investigator 1/2/3 flex (02-#155), range 14/16/18, located in Juneau

FY2024 Salary and Health Insurance Increases

	SalAdj	175.5	175.5	0.0	0.0	0.0	0.0	0.0	0.0	0	0	0
1004 Gen Fund		145.7										
1007 I/A Rcpts		12.7										
1037 GF/MH		15.1										
1092 MHTAAR		2.0										

FY2024 Salary and Health Insurance Increases: \$175.5FY2024 GGU cost of living increase 2.5%: \$158.7

FY2024 SU cost of living increase 1%: \$5.7

Change Record Detail - Multiple Scenarios with Descriptions
Department of Administration

Component: Office of Public Advocacy (43)
RDU: Legal and Advocacy Services (11)

Scenario/Change Record Title	Trans Type	Totals	Personal Services	Travel	Services	Commodities	Capital Outlay	Grants, Benefits	Miscellaneous	Positions		NP
										PFT	PPT	
FY2024 AlaskaCare insurance from \$1,685 to \$1,793 per member per month.: \$6.2												
FY2024 GGU health insurance increase from \$1,567.50 to \$1,573.50 per member per month.: \$4.9												
FY2024 PERS Rate Adjustment												
	SalAdj	46.5	46.5	0.0	0.0	0.0	0.0	0.0	0.0	0	0	0
1004 Gen Fund		40.9										
1007 I/A Rcpts		1.1										
1037 GF/MH		4.3										
1092 MHTAAR		0.2										
FY2024 PERS rate adjustment to 25.10%: \$46.5												
FY2024 AlaskaCare Health Insurance Increase - Exempt and Partially Exempt												
	SalAdj	111.1	111.1	0.0	0.0	0.0	0.0	0.0	0.0	0	0	0
1004 Gen Fund		103.3										
1037 GF/MH		7.8										
FY2024 AlaskaCare health insurance increase for exempt and partially exempt employees from \$1,685 to \$1,793 per member per month.: \$111.1												
MH Trust: Public Guardian Position for Office of Child Services Transition (FY24-FY27)												
	IncT	135.5	113.4	5.0	17.1	0.0	0.0	0.0	0.0	1	0	0
1092 MHTAAR		135.5										
Trust funds will be used to support a full-time Public Guardian position in the Department of Administration, Office of Public Advocacy. Public guardians serve adult Trust beneficiaries found to be incapacitated by the Superior court. Public guardians are required to maintain benefits, manage finances, make medical decisions, and ensure suitable housing for each Trust beneficiary. Assisting Trust beneficiaries with these needs improves public protection and State resource management by giving them the ability to live safely in their communities rather than in State hospitals or correctional institutions. The position is located in Anchorage and works statewide with Trust beneficiaries who are aging out of the Office of Child Services system. This position supports the Office of Public Advocacy's strategic plan to bring down current public guardian caseloads from approximately 100 cases per public guardian to the recommended national maximum of 40 case per public guardian, resulting in improved services, supports, and overall management of Trust beneficiaries.												
Full-time Public Guardian 2 (02-#145), range 18, located in Anchorage												
MH Trust: Public Guardian Position (FY19-FY25)												
	IncT	91.5	89.5	2.0	0.0	0.0	0.0	0.0	0.0	0	0	0
1092 MHTAAR		91.5										
Trust funds will be used to support a full-time Public Guardian position in the Department of Administration, Office of Public Advocacy. The position is located in Anchorage and serves the Western Alaska region including Bethel, Dillingham, Naknek, and surrounding communities. Public guardians serve adult Trust beneficiaries found to be incapacitated by the Superior court. Public guardians are required to maintain benefits, manage finances, make medical decisions, and ensure suitable housing for each Trust beneficiary. Assisting Trust beneficiaries with these needs improves public protection and State resource management by												

Change Record Detail - Multiple Scenarios with Descriptions
Department of Administration

Component: Office of Public Advocacy (43)
RDU: Legal and Advocacy Services (11)

Scenario/Change Record Title	Trans Type	Totals	Personal Services	Travel	Services	Commodities	Capital Outlay	Grants, Benefits	Miscellaneous	Positions		
										PFT	PPT	NP
giving them the ability to live safely in their communities rather than in State hospitals or even correctional institutions. This position supports the Office of Public Advocacy's strategic plan to bring down current public guardian caseloads from approximately 100 cases per public guardian to the recommended national maximum of 40 cases per public guardian, resulting in improved services, supports, and overall management of Trust beneficiaries.												
	Totals	34,801.5	25,441.9	337.2	8,783.4	239.0	0.0	0.0	0.0	167	2	12

Line Item Detail (1676)
Department of Administration
Travel

Component: Office of Public Advocacy (43)

Line Number	Line Name		FY2022 Actuals	FY2023 Management Plan	FY2024 Governor
2000	Travel		155.6	329.8	337.2
Object Class	Servicing Agency	Explanation	FY2022 Actuals	FY2023 Management Plan	FY2024 Governor
2000 Travel Detail Totals			155.6	329.8	337.2
2000	In-State Employee Travel	Transportation costs for travel relating to administration, training, conventions and meetings, boards and commissions	149.7	300.0	307.0
2001	In-State Non-Employee Travel	Transportation costs for travel relating to meetings and boards for non-employees	4.2	25.0	25.0
2002	Out of State Employee Travel	Transportation costs for staff travel out of state to national organization meetings, conferences, and training	1.7	4.8	5.2

Line Item Detail (1676)
Department of Administration
Services

Component: Office of Public Advocacy (43)

Line Number	Line Name		FY2022 Actuals	FY2023 Management Plan	FY2024 Governor
3000	Services		9,456.4	7,438.6	8,783.4
Object Class	Servicing Agency	Explanation	FY2022 Actuals	FY2023 Management Plan	FY2024 Governor
3000 Services Detail Totals			9,456.4	7,438.6	8,783.4
3000	Education Services	Training, educational conferences, agency memberships, and employee tuition	58.5	57.0	56.2
3002	Legal and Judicial Services	Legal and judicial services, including costs to conduct hearings and mediation	6,117.6	3,566.9	4,696.1
3003	Information Technology	Software licensing and maintenance, training, and consulting	58.7	91.9	91.9
3004	Telecommunications	Local, long distance, and cellular telephone charges, television, data/network, telecommunication equipment, and other wireless charges from outside vendors	50.3	55.3	56.0
3006	Delivery Services	Freight, courier services, and postage	92.3	95.3	98.0
3008	Utilities	Electricity, heating fuel, water, sewage, and disposal services	13.3	16.2	16.2
3009	Structure/Infrastructure/Land	Structure, infrastructure and land repairs, maintenance, rental, and leases	199.2	207.5	208.0
3010	Equipment/Machinery	Machinery, furniture and office equipment purchase, repairs, maintenance, rentals, and leases	26.9	148.3	149.0
3011	Other Services	Miscellaneous services including interpreter services, fingerprinting	62.6	60.0	60.0
3017	Inter-Agency Information Technology Non-Telecommunications	Admin - Alaska Division of IT (3141) OIT Core Services	520.2	550.0	560.0

Line Item Detail (1676)
Department of Administration
Services

Component: Office of Public Advocacy (43)

Object Class	Servicing Agency	Explanation	FY2022 Actuals	FY2023 Management Plan	FY2024 Governor	
3000 Services Detail Totals			9,456.4	7,438.6	8,783.4	
3017	Inter-Agency Information Technology Non-Telecommunications	Admin - Alaska Division of IT (3141)	OIT Server Hosting & SQL	13.1	43.0	40.0
3017	Inter-Agency Information Technology Non-Telecommunications	Admin - Alaska Division of IT (3141)	OIT Microsoft License Pass-Through Billing	3.0	3.0	3.0
3018	Inter-Agency Information Technology Telecommunications	Admin - Alaska Division of IT (3141)	OIT Telecommunications (CISCO device config, deployment, maintenance, replacements, and other telephone line services)	53.4	70.0	75.0
3021	Inter-Agency Mail	Admin - Print Services (2333)	Centralized mail services chargeback	6.4	7.0	8.0
3022	Inter-Agency Human Resources	Admin - Personnel (56)	Centralized Human Resource chargeback	113.5	120.0	125.0
3023	Inter-Agency Building Leases	Admin - OFC of Procure. Property. Mngmt. (3291)	State Owned Leasing	151.5	160.0	165.0
3023	Inter-Agency Building Leases	Admin - OFC of Procure. Property. Mngmt. (3291)	Private Owned Leasing	1,105.2	1,200.0	1,380.0
3024	Inter-Agency Legal	Courts - Department-wide	Dept of Law / Public Guardian Legal Services	0.0	20.0	15.0
3024	Inter-Agency Legal	H&SS - Department-wide	(Dept) Reimbursement for HCS Guardianship clients Federal funding	250.0	250.0	250.0
3024	Inter-Agency Legal	Law - Department-wide	(Dept) Dept of Law Appellate and Grand Jury Transcripts	72.5	140.0	140.0
3026	Inter-Agency Insurance	Admin - Risk Management (71)	(Dept) Division of Risk Management - Risk Management Insurance Charges	0.0	16.5	17.0
3027	Inter-Agency Financial	Admin - Accounting (3134)	(Dept) SSoA Accounts Payable and Travel chargeback	42.0	45.0	47.0
3027	Inter-Agency Financial	Admin - Finance (59)	Division of Finance Chargeback for IRIS FIN, HRM, and ALDER	37.2	88.7	90.0
3028	Inter-Agency Americans with Disabilities Act Compliance	Admin - Accounting (3134)	Americans with Disabilities Act (ADA) Chargeback	1.8	2.0	2.0

Line Item Detail (1676)
Department of Administration
Services

Component: Office of Public Advocacy (43)

Object Class		Servicing Agency	Explanation	FY2022 Actuals	FY2023 Management Plan	FY2024 Governor
3000 Services Detail Totals				9,456.4	7,438.6	8,783.4
3038	Inter-Agency Management/Consulting	Admin - Administrative Services (46)	(Dept) Administrative chargeback	184.2	190.0	195.0
3038	Inter-Agency Management/Consulting	Admin - OFC of Procure. Property. Mngmt. (3291)	(Dept) SSoA Procurement chargeback	23.2	25.0	25.0
3038	Inter-Agency Management/Consulting	Admin - Office of the Commissioner (45)	(Dept) Commissioner's Office chargeback	199.8	210.0	215.0

Line Item Detail (1676)
Department of Administration
Commodities

Component: Office of Public Advocacy (43)

Line Number	Line Name		FY2022 Actuals	FY2023 Management Plan	FY2024 Governor
4000	Commodities		210.1	232.4	239.0
Object Class	Servicing Agency	Explanation	FY2022 Actuals	FY2023 Management Plan	FY2024 Governor
4000 Commodities Detail Totals			210.1	232.4	239.0
4000	Business	General business supplies such as office consumables, furniture, and computer equipment	209.8	232.4	239.0
4002	Household/Institutional	Cleaning, food and other household supplies	0.3	0.0	0.0

Revenue Detail (1681)
Department of Administration

Component: Office of Public Advocacy (43)

Revenue Type (OMB Fund Code) Revenue Source	Component	Comment	FY2022 Actuals	FY2023 Management Plan	FY2024 Governor
5002 Fed Rcpts (1002 Fed Rcpts)			229.5	264.0	50.0
5013 Federal Public Protection - Victims of Crime Act		Court Appointed Special Advocates (CASA) - Federal Grant Nat'l CASA	160.7	0.0	0.0
5014 Federal Public Protection - Miscellaneous Grants		Court Appointed Special Advocates (CASA) - Federal Grant Valley	3.2	0.0	0.0
5014 Federal Public Protection - Miscellaneous Grants		Court Appointed Special Advocates (CASA) - Federal Grant Juneau	5.6	0.0	0.0
5014 Federal Public Protection - Miscellaneous Grants		Court Appointed Special Advocates (CASA) - Federal Core Model Grant	60.0	0.0	0.0
5014 Federal Public Protection - Miscellaneous Grants		Uncollectible Federal Receipts	0.0	264.0	50.0
5005 GF/Prgm (1005 GF/Prgm)			2,212.2	2,085.9	2,085.9
5102 Program Receipts Public Protection - Fines and Forfeitures		Reimbursement of fees collected by the Department of Law (Rule 39).	276.3	150.0	150.0
5103 Program Receipts - Charges for Services		Public Guardian fees	1,935.9	1,935.9	1,935.9
5007 I/A Rcpts (1007 I/A Rcpts)			900.0	1,000.0	1,000.0
5301 Inter-Agency Receipts	FCS - Department-wide	Reimbursable Services Agreement for Title IV Federal reimbursement	400.0	500.0	500.0
5301 Inter-Agency Receipts	H&SS - Department-wide	Reimbursable Services Agreement for HCS Support for Guardianship Clients	500.0	500.0	500.0
5108 Stat Desig (1108 Stat Desig)			95.3	0.0	0.0
5209 Statutory Designated Program Receipts - Gifts/Grants/Bequest		Court Appointed Special Advocates (CASA) - Municipality of Anchorage Alcohol Sales Tax Grant	95.3	0.0	0.0
6004 Gen Fund (1004 Gen Fund)			4.1	2.0	2.0
6046 General Fund - Prior Year Reimbursement Recovery		Prior year recovery	4.1	2.0	2.0

Inter-Agency Services (1682)
Department of Administration

Component: Office of Public Advocacy (43)

				FY2022 Actuals	FY2023 Management Plan	FY2024 Governor
Component Totals				2,777.0	3,140.2	3,352.0
With Department of Administration				2,454.5	2,730.2	2,947.0
With Judiciary				0.0	20.0	15.0
With Department of Health & Social Services				250.0	250.0	250.0
With Department of Law				72.5	140.0	140.0
Object Class	Servicing Agency	Explanation		FY2022 Actuals	FY2023 Management Plan	FY2024 Governor
3017	Inter-Agency Information Technology Non-Telecommunications	Admin - Alaska Division of IT (3141)	OIT Core Services	520.2	550.0	560.0
3017	Inter-Agency Information Technology Non-Telecommunications	Admin - Alaska Division of IT (3141)	OIT Server Hosting & SQL	13.1	43.0	40.0
3017	Inter-Agency Information Technology Non-Telecommunications	Admin - Alaska Division of IT (3141)	OIT Microsoft License Pass-Through Billing	3.0	3.0	3.0
3018	Inter-Agency Information Technology Telecommunications	Admin - Alaska Division of IT (3141)	OIT Telecommunications (CISCO device config, deployment, maintenance, replacements, and other telephone line services)	53.4	70.0	75.0
3021	Inter-Agency Mail	Admin - Print Services (2333)	Centralized mail services chargeback	6.4	7.0	8.0
3022	Inter-Agency Human Resources	Admin - Personnel (56)	Centralized Human Resource chargeback	113.5	120.0	125.0
3023	Inter-Agency Building Leases	Admin - OFC of Procure. Property. Mngmt. (3291)	State Owned Leasing	151.5	160.0	165.0
3023	Inter-Agency Building Leases	Admin - OFC of Procure. Property. Mngmt. (3291)	Private Owned Leasing	1,105.2	1,200.0	1,380.0
3024	Inter-Agency Legal	Courts - Department-wide	Dept of Law / Public Guardian Legal Services	0.0	20.0	15.0
3024	Inter-Agency Legal	H&SS - Department-wide	(Dept) Reimbursement for HCS Guardianship clients Federal funding	250.0	250.0	250.0
3024	Inter-Agency Legal	Law - Department-wide	(Dept) Dept of Law Appellate and Grand Jury Transcripts	72.5	140.0	140.0

Inter-Agency Services (1682)
Department of Administration

Component: Office of Public Advocacy (43)

Object Class	Servicing Agency	Explanation	FY2022 Actuals	FY2023 Management Plan	FY2024 Governor
3026 Inter-Agency Insurance	Admin - Risk Management (71)	(Dept) Division of Risk Management - Risk Management Insurance Charges	0.0	16.5	17.0
3027 Inter-Agency Financial	Admin - Accounting (3134)	(Dept) SSoA Accounts Payable and Travel chargeback	42.0	45.0	47.0
3027 Inter-Agency Financial	Admin - Finance (59)	Division of Finance Chargeback for IRIS FIN, HRM, and ALDER	37.2	88.7	90.0
3028 Inter-Agency Americans with Disabilities Act Compliance	Admin - Accounting (3134)	Americans with Disabilities Act (ADA) Chargeback	1.8	2.0	2.0
3038 Inter-Agency Management/Consulting	Admin - Administrative Services (46)	(Dept) Administrative chargeback	184.2	190.0	195.0
3038 Inter-Agency Management/Consulting	Admin - OFC of Procure. Property. Mngmt. (3291)	(Dept) SSoA Procurement chargeback	23.2	25.0	25.0
3038 Inter-Agency Management/Consulting	Admin - Office of the Commissioner (45)	(Dept) Commissioner's Office chargeback	199.8	210.0	215.0

Personal Services Expenditure Detail
Department of Administration

Scenario: FY2024 Governor (19867)
Component: Office of Public Advocacy (43)
RDU: Legal and Advocacy Services (11)

PCN	Job Class Title	Time Status	Retire Code	Barg Unit	Location	Salary Sched	Range / Step	Comp Months	Split / Count	Annual Salaries	COLA	Premium Pay	Annual Benefits	Total Costs	UGF Amount
02-#145	Public Guardian 2	FT	A	GG	Anchorage	200	18C	12.0		66,456	2,302	511	44,125	113,394	98,185
02-#152	Law Office Assistant 2	FT	A	GG	Palmer	200	13A	12.0		43,953	1,511	0	35,490	80,954	80,954
02-#153	Law Office Assistant 2	FT	A	GG	Fairbanks	203	13A	12.0		45,279	1,557	0	35,987	82,823	82,823
02-#154	Investigator 3	FT	A	GG	Fairbanks	203	18C	12.0		68,445	2,353	0	44,679	115,477	115,477
02-#155	Investigator 3	FT	A	GG	Juneau	105	18C	12.0		71,136	2,446	0	45,689	119,271	119,271
02-1136	Investigator 3	FT	A	SS	Anchorage	600	18F / J	12.0		82,014	1,128	0	52,444	135,586	135,586
02-1257	Attorney 4	FT	A	XE	Palmer	A00	24E / F	12.0		124,561	0	0	68,264	192,825	192,825
02-1387	Attorney 4	FT	A	XE	Fairbanks	A03	24F / J	12.0		135,265	0	0	72,280	207,545	207,545
02-1600	Division Director - Px	FT	A	XE	Anchorage	A00	27R	12.0		198,023	0	0	93,508	291,531	291,531
02-1601	Investigator 3	FT	A	GP	Anchorage	200	18B / C	12.0		64,436	2,215	0	43,175	109,826	109,826
02-1602	Paralegal 1	FT	A	GP	Anchorage	200	14B / C	12.0		49,998	1,757	1,119	38,178	91,052	91,052
02-1603	Law Office Assistant 1	FT	A	GP	Anchorage	200	11C / D	12.0		42,392	1,457	0	34,904	78,753	78,753
02-1604	Associate Attorney 2	FT	A	XE	Anchorage	N00	19K	12.0		85,274	0	0	53,523	138,797	138,797
02-1605	Associate Attorney 2	FT	A	XE	Fairbanks	99	19O	12.0		96,457	0	0	57,719	154,176	154,176
02-1606	Attorney 5	FT	A	XE	Fairbanks	A03	25Q	12.0		183,788	0	0	89,040	272,828	272,828
02-1607	Attorney 5	FT	A	XE	Anchorage	99	25P	12.0		145,224	0	0	76,017	221,241	221,241
02-1608	Attorney 5	FT	A	XE	Juneau	A05	25L / M	12.0		162,043	0	0	82,214	244,257	244,257
02-1609	Attorney 5	FT	A	XE	Anchorage	99	25P	12.0		145,226	0	0	76,017	221,243	221,243
02-1610	Attorney 4	FT	A	XE	Palmer	A00	24K / L	12.0		139,916	0	0	74,025	213,941	213,941
02-1611	Attorney 2	FT	A	XE	Fairbanks	A03	20A / B	12.0		88,242	0	0	54,637	142,879	142,879
02-1612	Attorney 4	FT	A	XE	Anchorage	A00	24C / D	12.0		116,350	0	0	65,183	181,533	181,533
02-1613	Paralegal 2	FT	A	GP	Fairbanks	203	16K / L	12.0		75,278	2,588	0	47,243	125,109	125,109
02-1614	Attorney 5	FT	A	XE	Fairbanks	A03	25L / M	12.0		157,260	0	0	80,533	237,793	237,793
02-1615	Paralegal 2	FT	A	GP	Anchorage	200	16A / B	12.0		55,499	1,908	0	39,822	97,229	97,229
02-1620	Accounting Technician 1	FT	A	GP	Anchorage	200	12B / C	12.0		43,680	1,502	0	35,387	80,569	80,569
02-1621	Public Guardian 3	FT	A	GP	Anchorage	200	20N / O	12.0		104,007	3,603	790	58,318	166,718	144,356
02-1622	Associate Attorney 2	FT	A	XE	Anchorage	N00	19M / N	12.0		91,156	0	0	55,730	146,886	146,886
02-1623	Eligibility Technician 2	FT	A	GP	Anchorage	200	14C / D	12.0		51,227	1,774	385	38,363	91,749	73,289
02-1625	Public Guardian 2	FT	A	GP	Anchorage	200	18L	12.0		84,338	2,922	648	50,885	138,793	120,177
02-1626	Public Guardian 2	FT	A	GP	Fairbanks	203	18C / D	12.0		69,991	2,424	526	45,457	118,398	102,517
02-1627	Public Guardian 2	FT	A	GP	Juneau	205	18C	12.0		69,771	2,417	536	45,378	118,102	94,340
02-1630	Associate Attorney 2	FT	A	XE	Anchorage	99	19N	12.0		89,837	0	0	55,235	145,072	145,072
02-1631	Paralegal 2	FT	A	GP	Fairbanks	203	16K / L	12.0		74,525	2,562	0	46,960	124,047	124,047
02-1632	Accounting Technician 1	FT	A	GP	Anchorage	200	12A / B	12.0		42,001	1,444	0	34,757	78,202	78,202
02-1633	Office Assistant 2	FT	A	GP	Anchorage	200	10B / C	12.0		38,454	1,322	0	33,427	73,203	73,203
02-1634	Associate Attorney 2	FT	A	XE	Anchorage	N00	19D / E	12.0		77,162	0	0	50,480	127,642	127,642
02-1635	Public Guardian 2	FT	A	GP	Anchorage	200	18E / F	12.0		73,103	2,532	546	46,632	122,813	31,813
02-1637	Associate Attorney 2	FT	A	XE	Anchorage	N00	19F / J	12.0		81,718	0	0	52,189	133,907	133,907

Note: If a position is split, an asterisk (*) will appear in the Split/Count column. If the split position is also counted in the component, two asterisks (**) will appear in this column. [No valid job title] appearing in the Job Class Title indicates that the PCN has an invalid class code or invalid range for the class code effective date of this scenario.

Personal Services Expenditure Detail
Department of Administration

Scenario: FY2024 Governor (19867)
Component: Office of Public Advocacy (43)
RDU: Legal and Advocacy Services (11)

PCN	Job Class Title	Time Status	Retire Code	Barg Unit	Location	Salary Sched	Range / Step	Comp Months	Split / Count	Annual Salaries	COLA	Premium Pay	Annual Benefits	Total Costs	UGF Amount
02-1638	Public Guardian 2	FT	A	GP	Palmer	200	18J / K	12.0		80,828	2,800	608	49,553	133,789	115,844
02-1639	Attorney 2	FT	A	XE	Anchorage	A00	20E / F	12.0		94,946	0	0	57,152	152,098	152,098
02-1640	Public Guardian 3	FT	A	GP	Anchorage	200	20M / N	12.0		101,193	3,505	765	57,253	162,716	140,891
02-1641	Public Guardian 2	FT	A	GP	Anchorage	200	18C / D	12.0		67,587	2,341	511	44,549	114,988	99,565
02-1642	Public Guardian 2	FT	A	GP	Juneau	205	18K	12.0		85,761	2,971	659	51,423	140,814	121,927
02-1643	Accountant 4	FT	A	SS	Anchorage	200	20K / L	12.0		98,686	1,357	0	58,700	158,743	158,743
02-1644	Associate Attorney 2	FT	A	XE	Anchorage	N00	19F	12.0		79,989	0	0	51,540	131,529	131,529
02-1645	Attorney 5	FT	A	XE	Anchorage	99	25Q	12.0		157,083	0	0	80,466	237,549	237,549
02-1646	Attorney 4	FT	A	XE	Anchorage	A00	24L / M	12.0		145,499	0	0	76,120	221,619	221,619
02-1647	Public Guardian 3	FT	A	GP	Palmer	200	20L / M	12.0		98,004	3,395	741	56,048	158,188	136,970
02-1648	Associate Attorney 2	FT	A	XE	Anchorage	N00	19F / J	12.0		82,258	0	0	52,392	134,650	134,650
02-1649	Attorney 6	FT	A	XE	Anchorage	A00	26P / Q	12.0		183,388	0	0	88,914	272,302	272,302
02-1650	Attorney 5	FT	A	XE	Juneau	A05	25K / L	12.0		159,457	0	0	81,357	240,814	240,814
02-1651	Attorney 3	FT	A	XE	Bethel	A50	22F	12.0		168,363	0	0	84,198	252,561	252,561
02-1652	Associate Attorney 2	FT	A	XE	Anchorage	N00	19D / E	12.0		76,291	0	0	50,153	126,444	126,444
02-1653	Associate Attorney 2	FT	A	XE	Anchorage	N00	19B / C	12.0		71,659	0	0	48,415	120,074	120,074
02-1654	Attorney 4	FT	A	XE	Fairbanks	A03	24C / D	12.0		121,935	0	0	67,279	189,214	189,214
02-1655	Public Guardian 3	FT	A	GP	Anchorage	200	20O	12.0		106,119	3,676	816	59,121	169,732	146,966
02-1656	Attorney 4	FT	A	XE	Anchorage	99	24N	12.0		125,514	0	0	68,621	194,135	194,135
02-1657	Associate Attorney 2	FT	A	XE	Anchorage	N00	19F / J	12.0		82,366	0	0	52,432	134,798	134,798
02-1658	Associate Attorney 2	FT	A	XE	Anchorage	99	19N	12.0		89,837	0	0	55,235	145,072	145,072
02-1659	Paralegal 2	FT	A	GP	Anchorage	200	16O	12.0		78,839	2,710	0	48,579	130,128	130,128
02-1660	Public Guardian 4	FT	A	SS	Anchorage	200	22Q	12.0		132,600	1,824	0	71,424	205,848	178,238
02-1661	Attorney 4	FT	A	XE	Anchorage	A00	24L / M	12.0		143,582	0	0	75,401	218,983	218,983
02-1664	Attorney 4	FT	A	XE	Anchorage	A00	24F	12.0		128,544	0	0	69,758	198,302	198,302
02-1665	Associate Attorney 2	FT	A	XE	Anchorage	N00	19E / F	12.0		78,929	0	0	51,143	130,072	130,072
02-1666	Paralegal 2	FT	A	GP	Kenai	200	16B / C	12.0		56,854	1,955	0	40,330	99,139	99,139
02-1667	Associate Attorney 2	FT	A	XE	Fairbanks	N03	19C / D	12.0		75,411	0	0	49,823	125,234	125,234
02-1668	Public Guardian 2	FT	A	GP	Anchorage	200	18C / D	12.0		67,587	2,341	511	44,549	114,988	99,565
02-1669	Paralegal 2	FT	A	SS	Anchorage	600	16J	12.0		70,262	987	1,521	48,606	121,376	121,376
02-1670	Administrative Assistant 1	FT	A	GP	Anchorage	200	12C / D	12.0		44,121	1,517	0	35,553	81,191	81,191
02-1671	Attorney 5	FT	A	XE	Palmer	A00	25J / K	12.0		143,223	0	0	75,266	218,489	218,489
02-1672	Attorney 4	FT	A	XE	Anchorage	A00	24B / C	12.0		113,927	0	0	64,274	178,201	178,201
02-1673	Paralegal 2	FT	A	GP	Palmer	200	16G / J	12.0		68,633	2,360	0	44,750	115,743	115,743
02-1674	Accounting Technician 3	FT	A	GP	Anchorage	200	16N	12.0		78,644	2,704	0	48,506	129,854	129,854
02-1676	Public Guardian 1	FT	A	GP	Anchorage	200	16B / C	12.0		56,301	1,950	429	40,284	98,964	98,964
02-1677	Paralegal 2	FT	A	GP	Anchorage	200	16G / J	12.0		67,854	2,333	0	44,457	114,644	114,644
02-1678	Paralegal 1	FT	A	GP	Bethel	250	14K	12.0		93,074	3,200	0	53,920	150,194	150,194

Note: If a position is split, an asterisk (*) will appear in the Split/Count column. If the split position is also counted in the component, two asterisks (**) will appear in this column. [No valid job title] appearing in the Job Class Title indicates that the PCN has an invalid class code or invalid range for the class code effective date of this scenario.

Personal Services Expenditure Detail
Department of Administration

Scenario: FY2024 Governor (19867)
Component: Office of Public Advocacy (43)
RDU: Legal and Advocacy Services (11)

PCN	Job Class Title	Time Status	Retire Code	Barg Unit	Location	Salary Sched	Range / Step	Comp Months	Split / Count	Annual Salaries	COLA	Premium Pay	Annual Benefits	Total Costs	UGF Amount
02-1679	Attorney 5	FT	A	XE	Bethel	A50	25O	12.0		251,063	0	0	110,158	361,221	361,221
02-1680	Attorney 5	FT	A	XE	Palmer	99	25O	12.0		167,369	0	0	83,886	251,255	251,255
02-1681	Attorney 5	FT	A	XE	Anchorage	99	25O	12.0		139,970	0	0	74,045	214,015	214,015
02-1682	Attorney 3	FT	A	XE	Anchorage	A00	22C / D	12.0		102,433	0	0	59,961	162,394	162,394
02-1683	Public Guardian 2	FT	A	GP	Anchorage	200	18D / E	12.0		69,794	2,418	528	45,383	118,123	102,279
02-1684	Attorney 5	FT	A	XE	Anchorage	A00	25L / M	12.0		153,870	0	0	79,261	233,131	233,131
02-1686	Attorney 4	FT	A	XE	Anchorage	A00	24K	12.0		137,027	0	0	72,941	209,968	209,968
02-1687	Investigator 3	FT	A	GP	Palmer	200	18M / N	12.0		88,619	3,047	0	52,249	143,915	143,915
02-1688	Attorney 4	FT	A	XE	Palmer	A00	24F	12.0		128,544	0	0	69,758	198,302	198,302
02-1689	Administrative Officer 1	FT	A	SS	Anchorage	200	17E / F	12.0		71,177	979	0	48,378	120,534	120,534
02-1690	Accounting Technician 3	FT	A	GP	Anchorage	200	16C / D	12.0		59,027	2,029	0	41,146	102,202	102,202
02-1691	Law Office Assistant 1	FT	A	GP	Anchorage	200	11B / C	12.0		41,038	1,411	0	34,396	76,845	76,845
02-1693	Attorney 4	FT	A	XE	Anchorage	A00	24C / D	12.0		119,881	0	0	66,508	186,389	186,389
02-1694	Attorney 4	FT	A	XE	Anchorage	A00	24K	12.0		137,027	0	0	72,941	209,968	209,968
02-1695	Attorney 5	FT	A	XE	Anchorage	A00	25L / M	12.0		152,842	0	0	78,875	231,717	231,717
02-1696	Attorney 4	FT	A	XE	Anchorage	A00	24B / C	12.0		112,710	0	0	63,817	176,527	176,527
02-1697	Attorney 5	FT	A	XE	Fairbanks	A03	25F	12.0		142,311	0	0	74,924	217,235	217,235
02-1698	Attorney 4	FT	A	XE	Fairbanks	A03	24J	12.0		136,695	0	0	72,817	209,512	209,512
02-1699	Paralegal 2	FT	A	GP	Fairbanks	203	16M	12.0		78,449	2,697	0	48,433	129,579	129,579
02-1700	Associate Attorney 2	FT	A	XE	Palmer	N00	19F	12.0		79,989	0	0	51,540	131,529	131,529
02-1701	Associate Attorney 2	FT	A	XE	Juneau	N05	19K / L	12.0		90,609	0	0	55,525	146,134	146,134
02-1702	Paralegal 1	FT	A	GP	Anchorage	200	14C / D	12.0		50,244	1,727	0	37,850	89,821	89,821
02-1703	Paralegal 1	FT	A	GP	Juneau	205	14C	12.0		52,650	1,810	0	38,753	93,213	93,213
02-1704	Law Office Assistant 2	FT	A	GP	Anchorage	200	13B / C	12.0		45,645	1,569	0	36,125	83,339	83,339
02-1705	Public Guardian 2	FT	A	GP	Anchorage	200	18D / E	12.0		68,851	2,385	528	45,030	116,794	93,295
02-1706	Office Assistant 2	FT	A	GP	Anchorage	200	10A / B	12.0		37,336	1,284	0	33,007	71,627	71,627
02-1707	Associate Attorney 2	FT	A	XE	Palmer	99	19N	12.0		89,837	0	0	55,235	145,072	145,072
02-1708	Law Office Assistant 2	FT	A	GP	Fairbanks	203	13B / C	12.0		47,373	1,629	0	36,773	85,775	85,775
02-1709	Investigator 3	FT	A	GP	Anchorage	200	18D / E	12.0		70,774	2,433	0	45,553	118,760	118,760
02-1710	Public Guardian 2	FT	A	GP	Anchorage	200	18C / D	12.0		68,584	2,375	511	44,923	116,393	92,975
02-1711	Law Office Assistant 2	FT	A	GP	Anchorage	200	13C / D	12.0		48,150	1,655	0	37,065	86,870	86,870
02-1712	Attorney 5	FT	A	XE	Anchorage	A00	25E / F	12.0		137,786	0	0	73,226	211,012	211,012
02-1713	Attorney 3	FT	A	XE	Anchorage	A00	22D	12.0		104,969	0	0	60,913	165,882	165,882
02-1714	Attorney 4	FT	A	XE	Fairbanks	A03	24A / B	12.0		115,049	0	0	64,695	179,744	179,744
02-1715	Law Office Assistant 2	FT	A	GP	Palmer	200	13G / J	12.0		55,784	1,918	0	39,929	97,631	97,631
02-1716	Attorney 4	FT	A	XE	Anchorage	99	24N	12.0		125,519	0	0	68,623	194,142	194,142
02-1717	Attorney 4	FT	A	XE	Anchorage	A00	24L / M	12.0		142,240	0	0	74,897	217,137	217,137
02-1718	Paralegal 2	FT	A	GP	Palmer	200	16L / M	12.0		74,808	2,572	0	47,067	124,447	124,447

Note: If a position is split, an asterisk (*) will appear in the Split/Count column. If the split position is also counted in the component, two asterisks (**) will appear in this column. [No valid job title] appearing in the Job Class Title indicates that the PCN has an invalid class code or invalid range for the class code effective date of this scenario.

Personal Services Expenditure Detail
Department of Administration

Scenario: FY2024 Governor (19867)
Component: Office of Public Advocacy (43)
RDU: Legal and Advocacy Services (11)

PCN	Job Class Title	Time Status	Retire Code	Barg Unit	Location	Salary Sched	Range / Step	Comp Months	Split / Count	Annual Salaries	COLA	Premium Pay	Annual Benefits	Total Costs	UGF Amount
02-1719	Attorney 6	FT	A	XE	Anchorage	A00	26L / M	12.0		158,162	0	0	80,871	239,033	239,033
02-1720	Attorney 4	FT	A	XE	Anchorage	A00	24F / J	12.0		131,500	0	0	70,867	202,367	202,367
02-1721	Attorney 3	FT	A	XE	Anchorage	A00	22B / C	12.0		162,884	0	0	82,478	245,362	245,362
02-1722	Paralegal 1	FT	A	GP	Anchorage	200	14B	12.0		48,497	1,667	0	37,195	87,359	87,359
02-1723	Law Office Assistant 2	FT	A	GP	Anchorage	200	13C	12.0		46,898	1,612	0	36,595	85,105	85,105
02-1724	Law Office Assistant 2	FT	A	GP	Juneau	205	13F / G	12.0		55,738	1,916	0	39,912	97,566	97,566
02-1725	Investigator 3	FT	A	GP	Anchorage	200	18J	12.0		79,112	2,720	0	48,681	130,513	130,513
02-1726	Public Guardian 2	FT	A	GP	Anchorage	200	18G	12.0		75,972	2,632	584	47,722	126,910	101,376
02-1727	Public Guardian 1	FT	A	GP	Anchorage	200	16B / C	12.0		56,301	1,950	429	40,284	98,964	98,964
02-1728	Attorney 4	FT	A	XE	Anchorage	99	24Q	12.0		140,191	0	0	74,128	214,319	214,319
02-1729	Public Guardian 2	FT	A	GP	Anchorage	200	18C / D	12.0		67,587	2,341	511	44,549	114,988	91,852
02-1730	Attorney 4	FT	A	XE	Anchorage	A00	24L	12.0		141,473	0	0	74,609	216,082	216,082
02-1731	Law Office Assistant 2	FT	A	GP	Anchorage	200	13G	12.0		53,859	1,852	0	39,207	94,918	94,918
02-1733	Project Assistant	PT	A	GP	Palmer	200	16B / C	12.0		41,355	1,422	0	25,016	67,793	67,793
02-1734	Project Assistant	PT	A	GP	Fairbanks	203	16A / B	12.0		28,211	970	0	20,084	49,265	49,265
02-1735	Associate Attorney 1	FT	A	XE	Anchorage	N00	17M / N	12.0		79,784	0	0	51,464	131,248	131,248
02-1736	Attorney 5	FT	A	XE	Kenai	A00	25K / L	12.0		233,357	0	0	104,600	337,957	337,957
02-1737	Associate Attorney 2	FT	A	XE	Palmer	N00	19J	12.0		82,583	0	0	52,514	135,097	135,097
02-1738	Attorney 4	FT	A	XE	Anchorage	A00	24J / K	12.0		133,794	0	0	71,728	205,522	205,522
02-1739	Attorney 3	FT	A	XE	Palmer	A00	22B / C	12.0		98,431	0	0	58,460	156,891	156,891
02-1740	Attorney 3	FT	A	XE	Anchorage	A00	22E / F	12.0		111,272	0	0	63,278	174,550	174,550
02-1741	Attorney 3	FT	A	XE	Anchorage	A00	22F	12.0		112,242	0	0	63,642	175,884	175,884
02-1742	Public Guardian 2	FT	A	GP	Fairbanks	203	18C / D	12.0		70,071	2,427	526	45,487	118,511	102,615
02-1743	Public Guardian 2	FT	A	GP	Palmer	200	18E / F	12.0		72,993	2,528	546	46,590	122,657	106,205
02-1744	Public Guardian 2	FT	A	GP	Anchorage	200	18D / E	12.0		68,851	2,385	528	45,030	116,794	101,128
02-1745	Attorney 3	FT	A	XE	Anchorage	A00	22D	12.0		104,969	0	0	60,913	165,882	165,882
02-1746	Eligibility Technician 2	FT	A	GP	Anchorage	200	14P	12.0		72,813	2,523	560	46,528	122,424	97,792
02-1747	Public Guardian 2	FT	A	GP	Anchorage	200	18J / K	12.0		80,935	2,803	608	49,594	133,940	106,991
02-1748	Law Office Assistant 3	FT	A	SS	Anchorage	600	14D / E	12.0		56,968	783	0	43,047	100,798	100,798
02-1749	Associate Attorney 2	FT	A	XE	Fairbanks	N03	19B / C	12.0		72,681	0	0	48,799	121,480	121,480
02-1750	Associate Attorney 2	FT	A	XE	Palmer	N00	19K / L	12.0		87,004	0	0	54,173	141,177	141,177
02-1751	Associate Attorney 2	FT	A	XE	Juneau	N05	19B / C	12.0		73,988	0	0	49,289	123,277	123,277
02-1752	Associate Attorney 2	FT	A	XE	Anchorage	N00	19F / J	12.0		82,258	0	0	52,392	134,650	134,650
02-1753	Attorney 4	FT	A	XE	Anchorage	A00	24F	12.0		128,544	0	0	69,758	198,302	198,302
02-1754	Attorney 4	FT	A	XE	Fairbanks	A03	24M	12.0		150,462	0	0	77,982	228,444	228,444
02-1755	Attorney 4	FT	A	XE	Anchorage	A00	24J	12.0		132,717	0	0	71,324	204,041	204,041
02-1756	Attorney 4	FT	A	XE	Juneau	A05	24F	12.0		134,979	0	0	72,173	207,152	207,152
02-1757	Attorney 2	FT	A	XE	Kenai	A00	20C	12.0		88,745	0	0	54,826	143,571	143,571

Note: If a position is split, an asterisk (*) will appear in the Split/Count column. If the split position is also counted in the component, two asterisks (**) will appear in this column. [No valid job title] appearing in the Job Class Title indicates that the PCN has an invalid class code or invalid range for the class code effective date of this scenario.

Personal Services Expenditure Detail
Department of Administration

Scenario: FY2024 Governor (19867)
Component: Office of Public Advocacy (43)
RDU: Legal and Advocacy Services (11)

PCN	Job Class Title	Time Status	Retire Code	Barg Unit	Location	Salary Sched	Range / Step	Comp Months	Split / Count	Annual Salaries	COLA	Premium Pay	Annual Benefits	Total Costs	UGF Amount
02-1758	Law Office Assistant 2	FT	A	GP	Anchorage	200	13C / D	12.0		47,337	1,627	0	36,759	85,723	85,723
02-1759	Law Office Assistant 2	FT	A	GP	Anchorage	200	13B / C	12.0		46,138	1,586	0	36,310	84,034	84,034
02-1760	Attorney 4	FT	A	XE	Palmer	A00	24C	12.0		115,986	0	0	65,047	181,033	181,033
02-1761	Attorney 5	FT	A	XE	Anchorage	A00	25F / J	12.0		140,213	0	0	74,137	214,350	214,350
02-1762	Paralegal 1	FT	A	GP	Anchorage	200	14C / D	12.0		50,291	1,729	0	37,868	89,888	89,888
02-1763	Attorney 4	FT	A	XE	Anchorage	A00	24C / D	12.0		118,789	0	0	66,098	184,887	184,887
02-1764	Investigator 2	FT	A	GP	Anchorage	200	16C / D	12.0		58,699	2,018	0	41,023	101,740	101,740
02-1765	Attorney 4	FT	A	XE	Anchorage	A00	24J / K	12.0		134,692	0	0	72,065	206,757	206,757
02-1766	Law Office Assistant 2	FT	A	GP	Palmer	200	13A / B	12.0		90,724	3,119	0	53,038	146,881	146,881
02-1767	Public Guardian 2	FT	A	GP	Anchorage	200	18C / D	12.0		68,584	2,375	511	44,923	116,393	92,975
02-1768	Attorney 5	FT	A	XE	Anchorage	A00	25M	12.0		156,995	0	0	80,433	237,428	237,428
02-1769	Attorney 4	FT	A	XE	Anchorage	A00	24J	12.0		132,717	0	0	71,324	204,041	204,041
02-1770	Attorney 4	FT	A	XE	Anchorage	A00	24N / O	12.0		154,973	0	0	79,674	234,647	234,647
02-1771	Paralegal 1	FT	A	GP	Anchorage	200	14B / C	12.0		50,107	1,761	1,119	38,219	91,206	91,206
02-1772	Project Assistant	FT	A	GP	Anchorage	200	16C / D	12.0		58,408	2,008	0	40,913	101,329	101,329
02-1773	Attorney 4	FT	A	XE	Bethel	A50	24F	12.0		192,816	0	0	91,874	284,690	284,690
02-4119	Attorney 3	FT	A	XE	Anchorage	A00	22E / F	12.0		108,847	0	0	62,368	171,215	171,215
02-N07051	Office Assistant 1	NP	N	GP	Anchorage	200	8A / A	12.0		115,023	3,166	0	11,629	129,818	129,818
02-N07052	Law Office Assistant 1	NP	N	GP	Anchorage	200	11A / A	12.0		107,892	2,970	0	10,908	121,770	121,770
02-N13014	Paralegal 1	NP	N	GP	Anchorage	200	14C / C	12.0		55,534	1,561	1,156	5,731	63,982	63,982
02-N15020	Law Office Assistant 1	NP	N	GP	Juneau	205	11A / A	12.0		40,911	1,126	0	4,136	46,173	46,173
02-N19012	Program Coordinator 1	NP	N	GP	Anchorage	200	18A / A	12.0		62,049	1,744	0	26,705	90,498	90,498
02-N19041	Law Office Assistant 1	NP	N	GP	Fairbanks	203	11A / A	12.0		40,131	1,105	0	4,057	45,293	45,293
02-N20006	Office Assistant 1	NP	N	GP	Kenai	200	8A / A	12.0		32,507	895	0	3,286	36,688	36,688
02-N20019	Investigator 2	NP	N	GP	Fairbanks	203	16A / A	12.0		55,478	1,559	0	25,889	82,926	82,926
02-N21014	Project Assistant	NP	N	GP	Juneau	205	16A / A	12.0		56,550	1,589	0	26,022	84,161	84,161
02-N21015	Office Assistant 1	NP	N	GP	Bethel	250	8A / A	12.0		4,502	124	0	455	5,081	5,081
02-TPX003	Attorney 1	NP	N	XE	Anchorage	A00	18A / A	12.0		72,618	0	0	7,342	79,960	79,960
02-TPX006	Attorney 2	NP	N	XE	Palmer	A00	20A / A	12.0		76,536	0	0	31,034	107,570	107,570

Note: If a position is split, an asterisk (*) will appear in the Split/Count column. If the split position is also counted in the component, two asterisks (**) will appear in this column. [No valid job title] appearing in the Job Class Title indicates that the PCN has an invalid class code or invalid range for the class code effective date of this scenario.

Personal Services Expenditure Detail
Department of Administration

Scenario: FY2024 Governor (19867)
Component: Office of Public Advocacy (43)
RDU: Legal and Advocacy Services (11)

PCN	Job Class Title	Time Status	Retire Code	Barg Unit	Location	Salary Sched	Range / Step	Comp Months	Split / Count	Annual Salaries	COLA	Premium Pay	Annual Benefits	Total Costs	UGF Amount
		Total Positions	New	Deleted										Total Salary Costs:	17,068,904
														Total COLA:	186,181
	Full Time Positions:	167	5	0										Total Premium Pay:	20,267
	Part Time Positions:	2	0	0										Total Benefits:	9,713,100
	Non Permanent Positions:	12	0	0											
	Positions in Component:	181	5	0											
	Total Component Months:	2,172.0													
														Total Pre-Vacancy:	26,988,452
														Minus Vacancy Adjustment of 5.73%:	(1,546,552)
														Total Post-Vacancy:	25,441,900
														Plus Lump Sum Premium Pay:	0
														Personal Services Line 100:	25,441,900

PCN Funding Sources:	Pre-Vacancy	Post-Vacancy	Percent
1004 General Fund Receipts	24,137,178	22,754,016	89.44%
1007 Interagency Receipts	509,832	480,617	1.89%
1037 General Fund / Mental Health	2,250,442	2,121,482	8.34%
1092 Mental Health Trust Authority Authorized Receipts	91,000	85,785	0.34%
Total PCN Funding:	26,988,452	25,441,900	100.00%

Note: If a position is split, an asterisk (*) will appear in the Split/Count column. If the split position is also counted in the component, two asterisks (**) will appear in this column. [No valid job title] appearing in the Job Class Title indicates that the PCN has an invalid class code or invalid range for the class code effective date of this scenario.

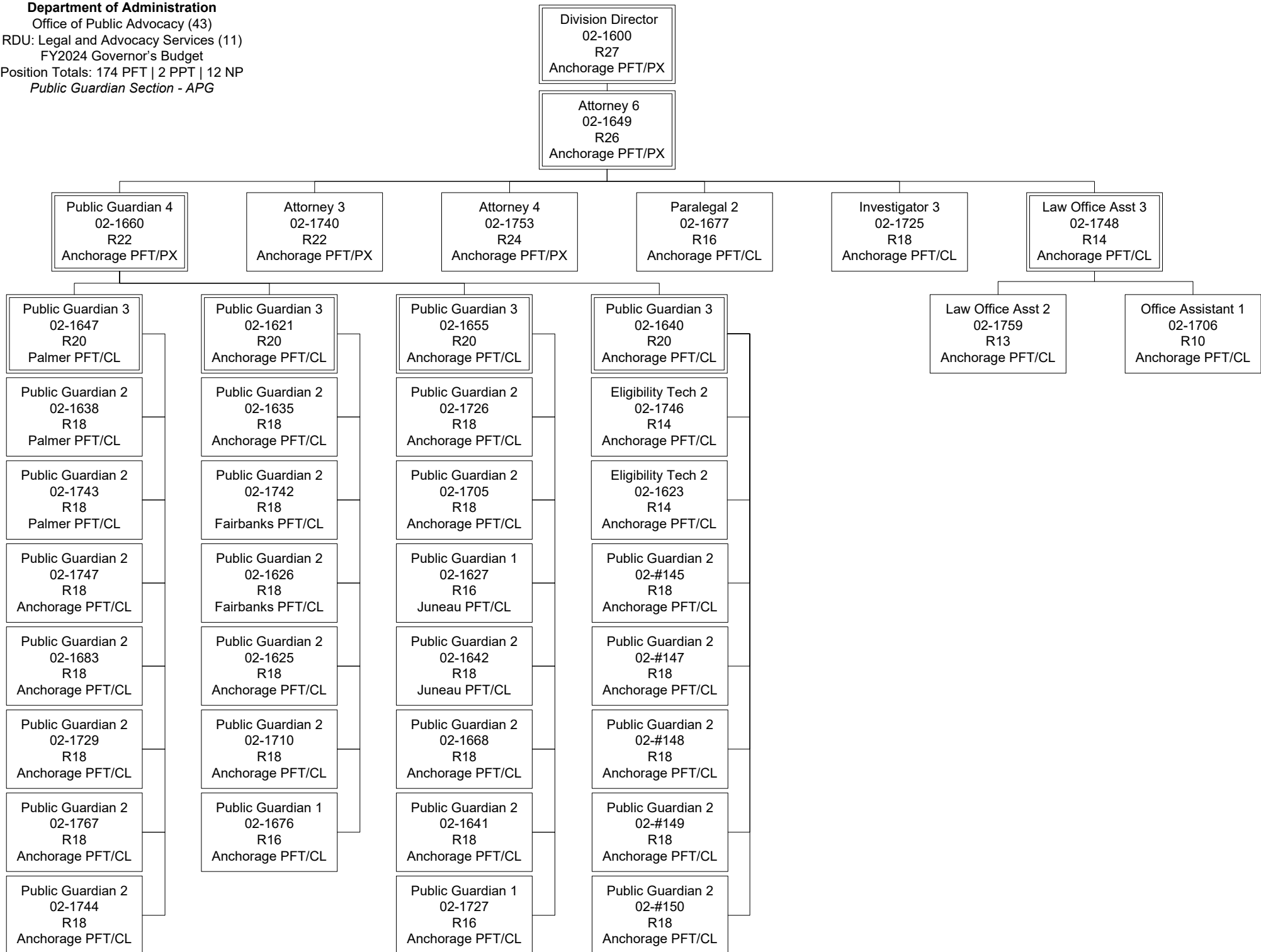

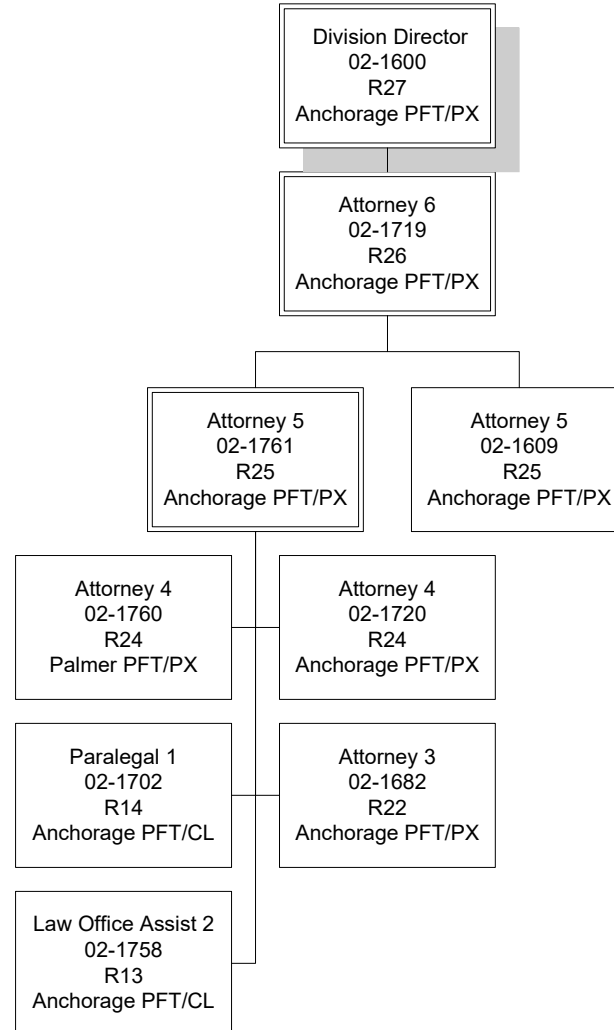

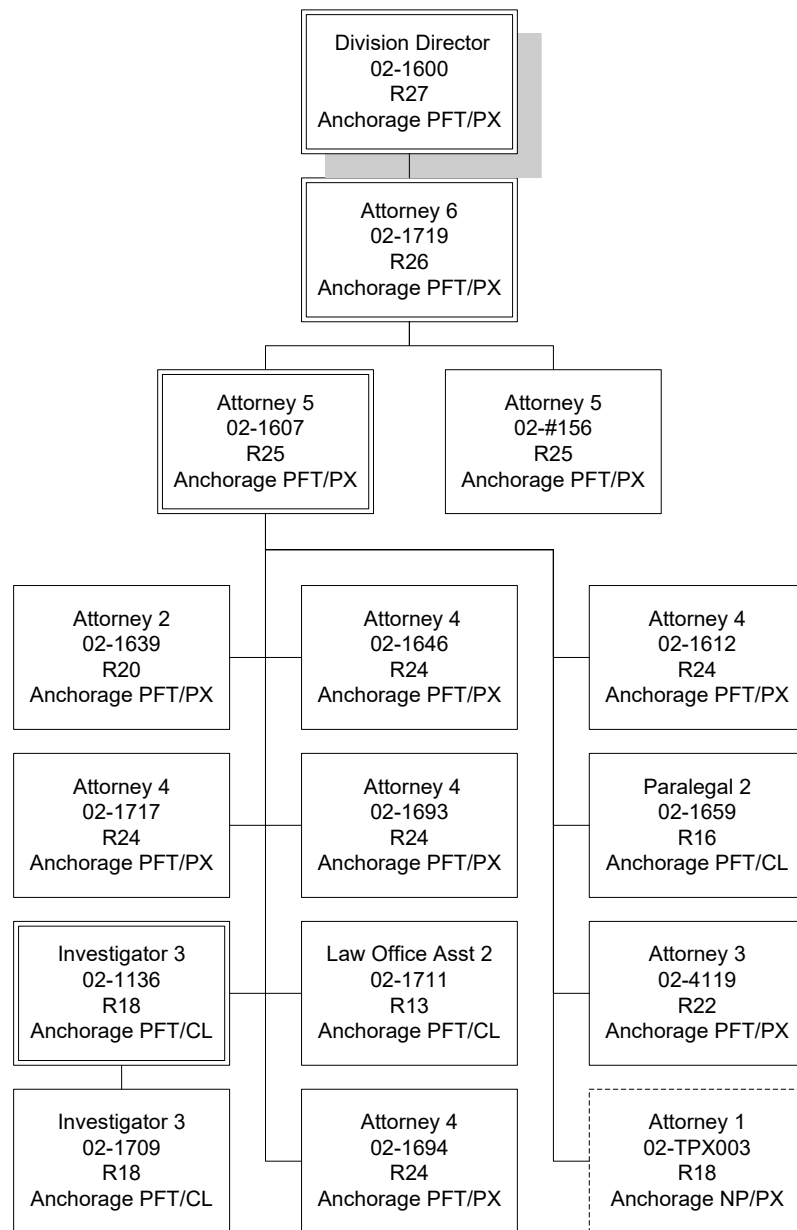

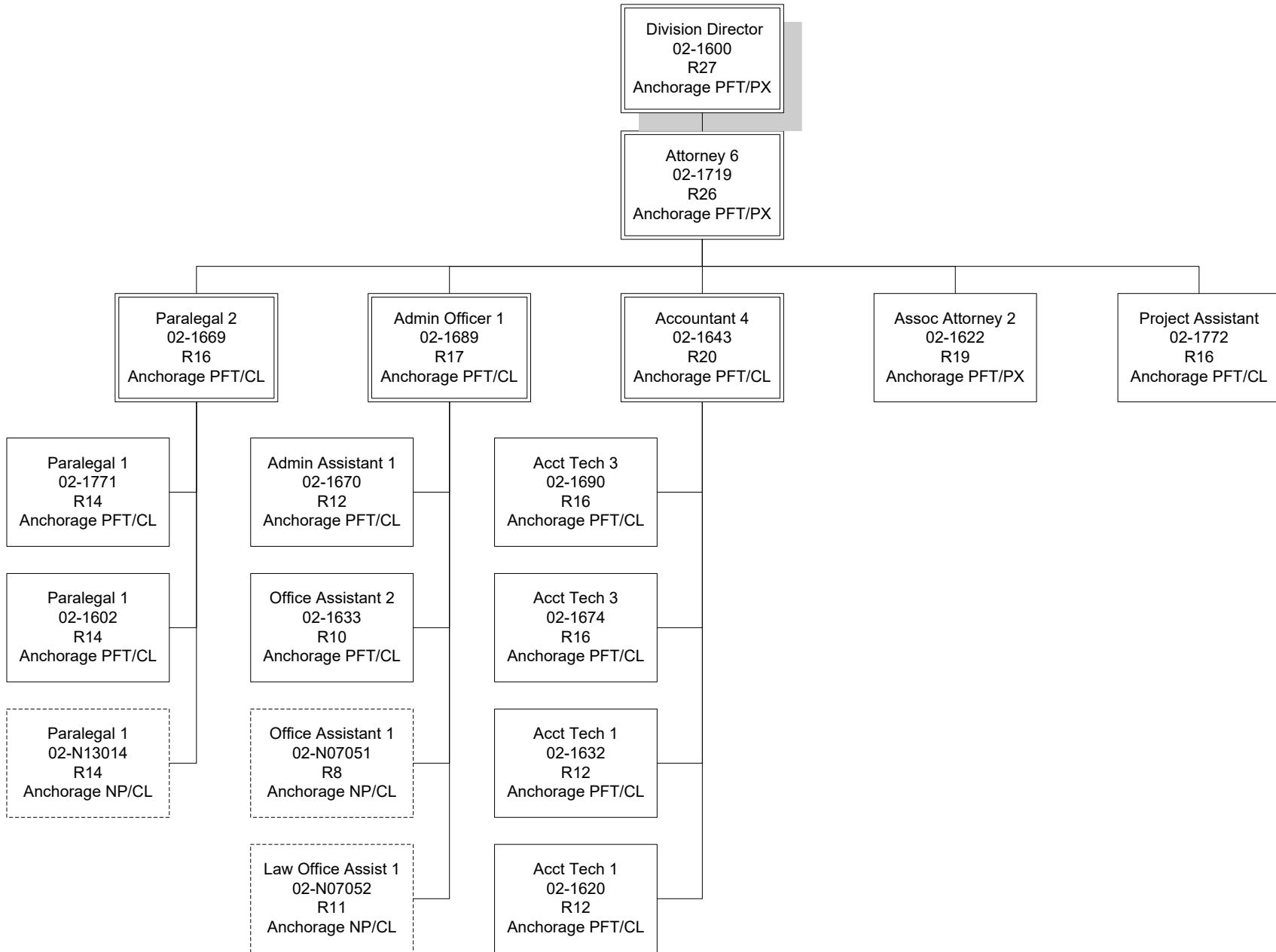

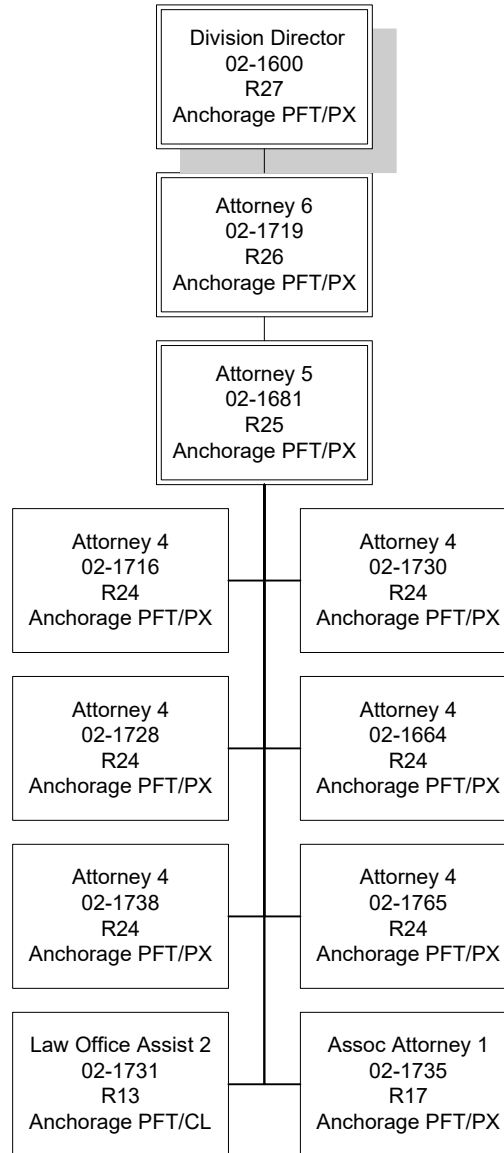

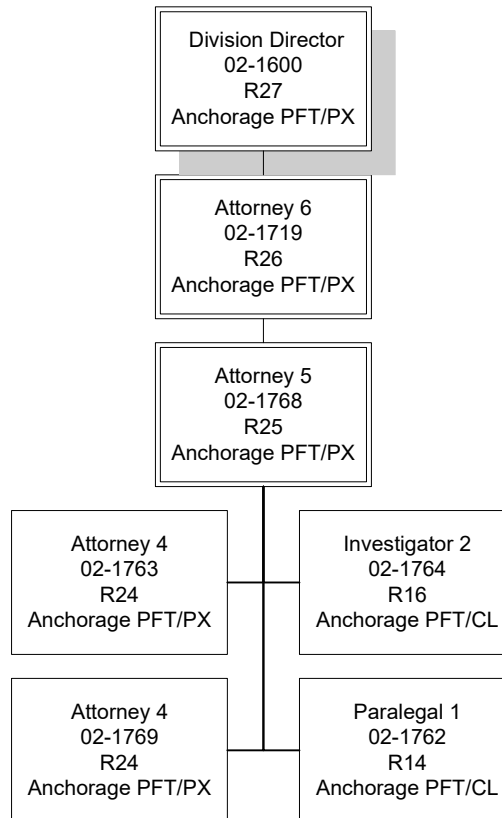

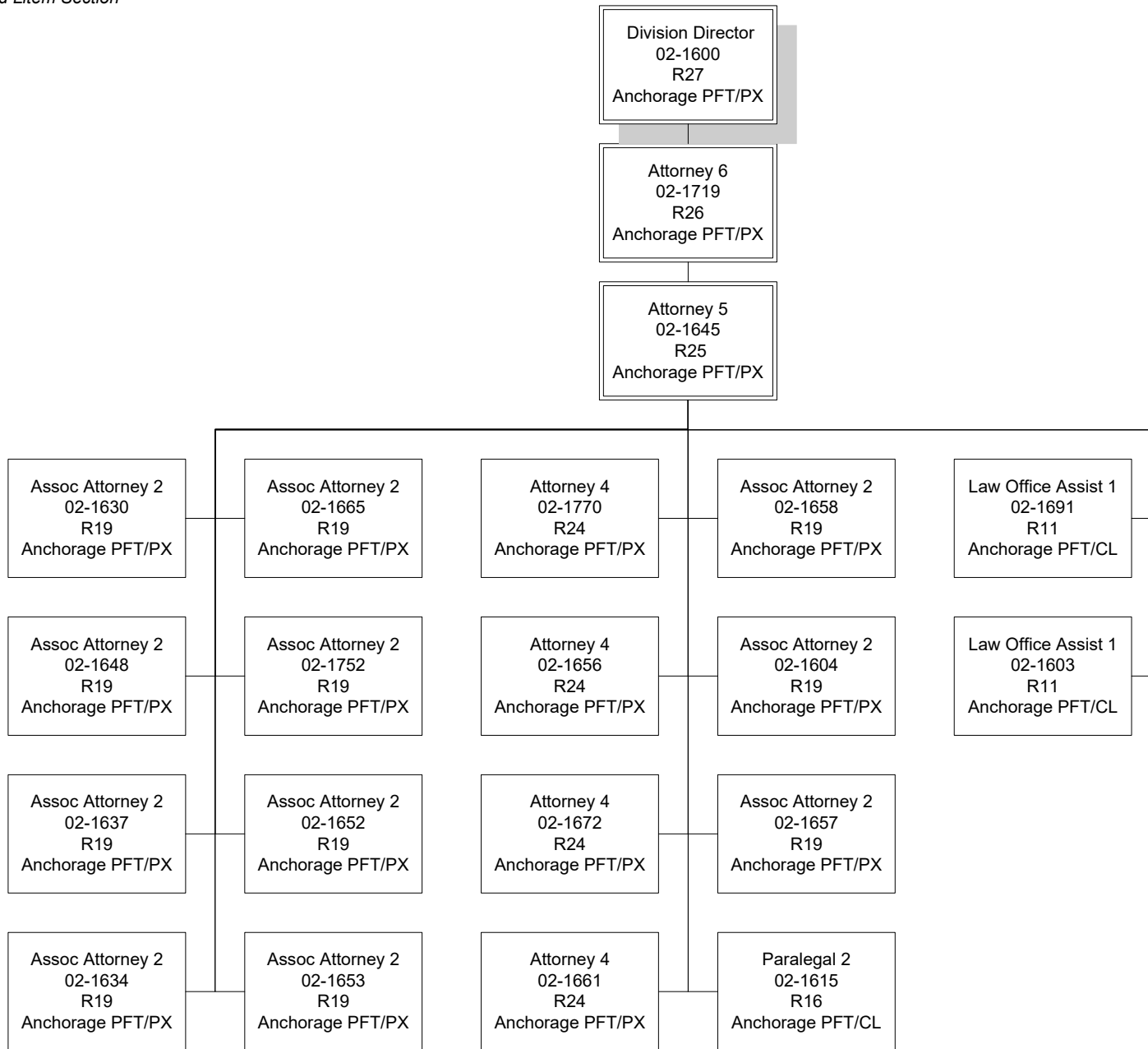

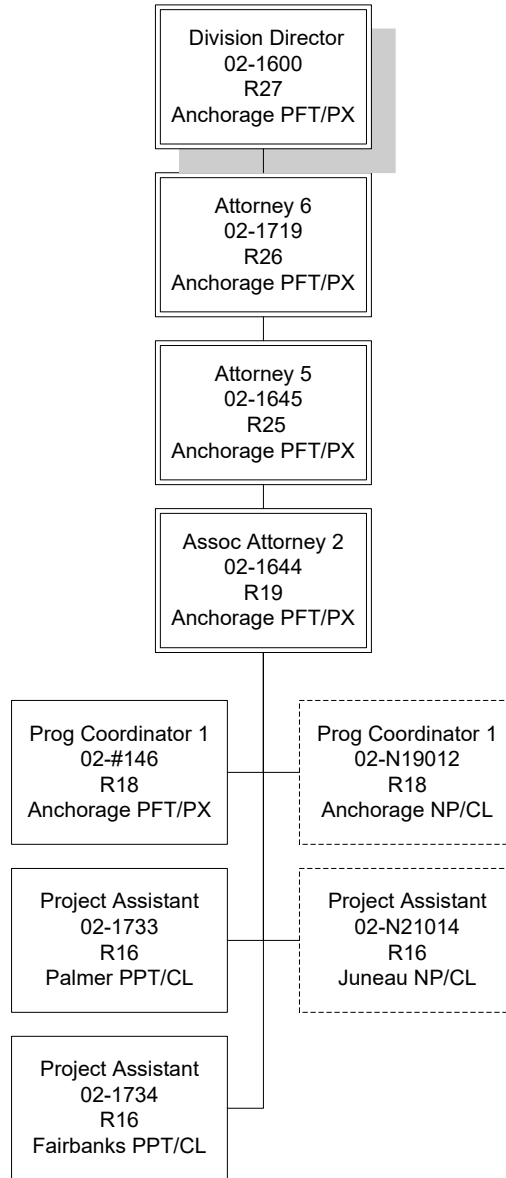

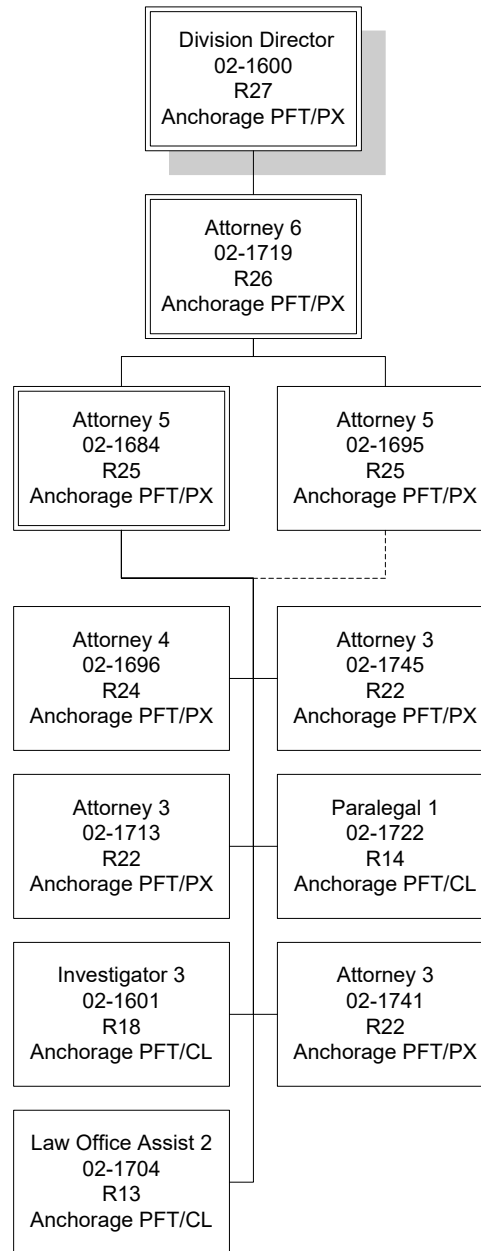

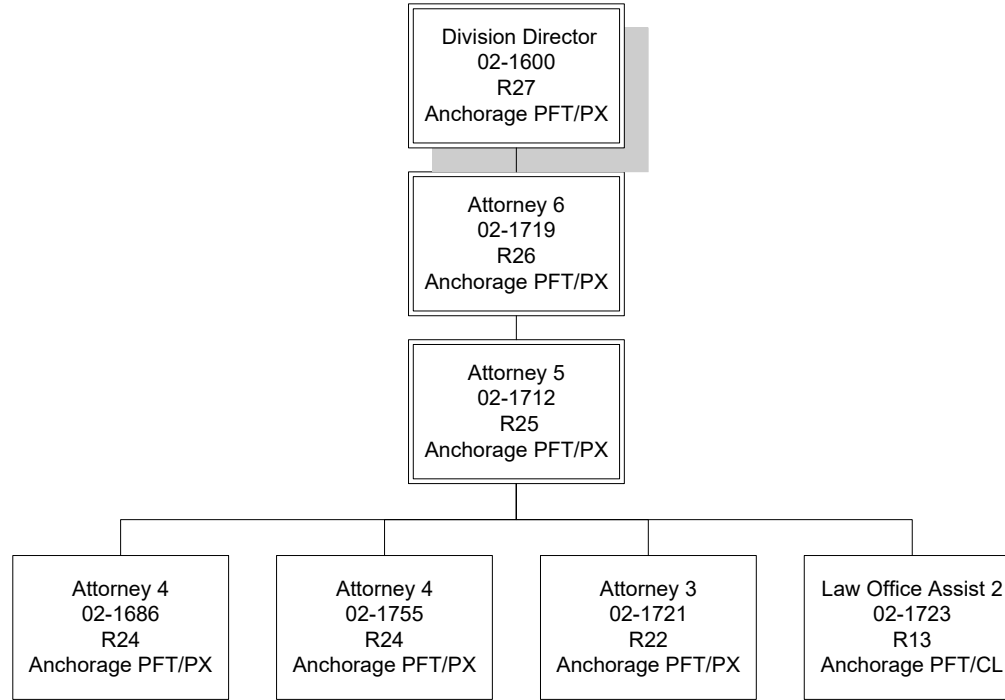

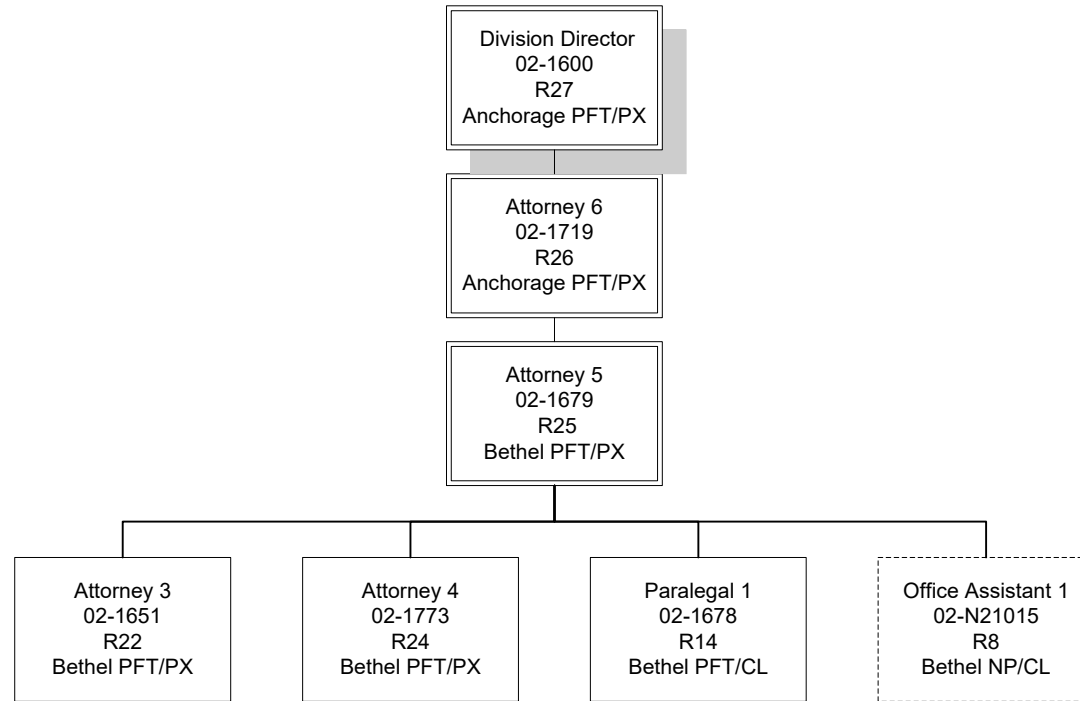

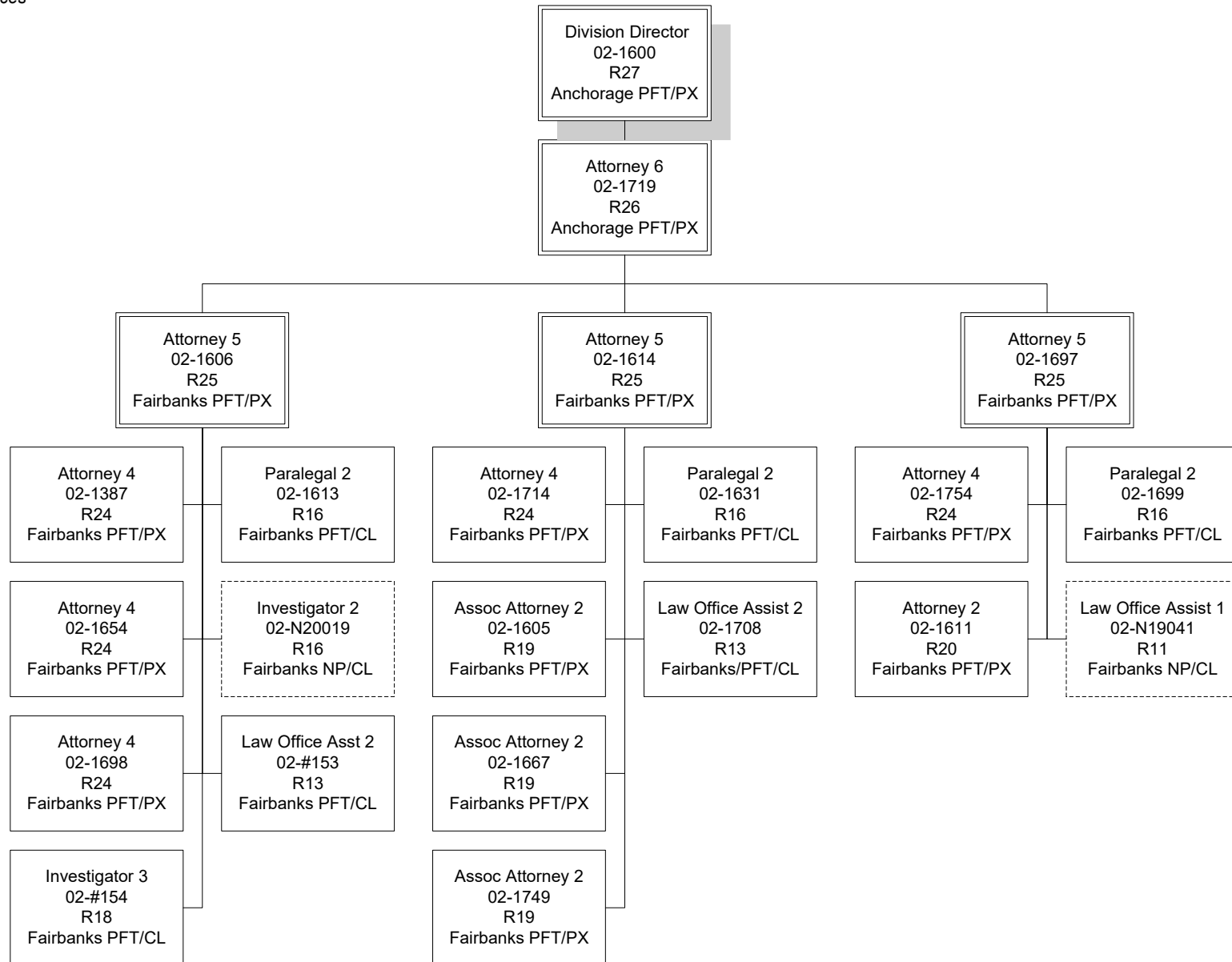

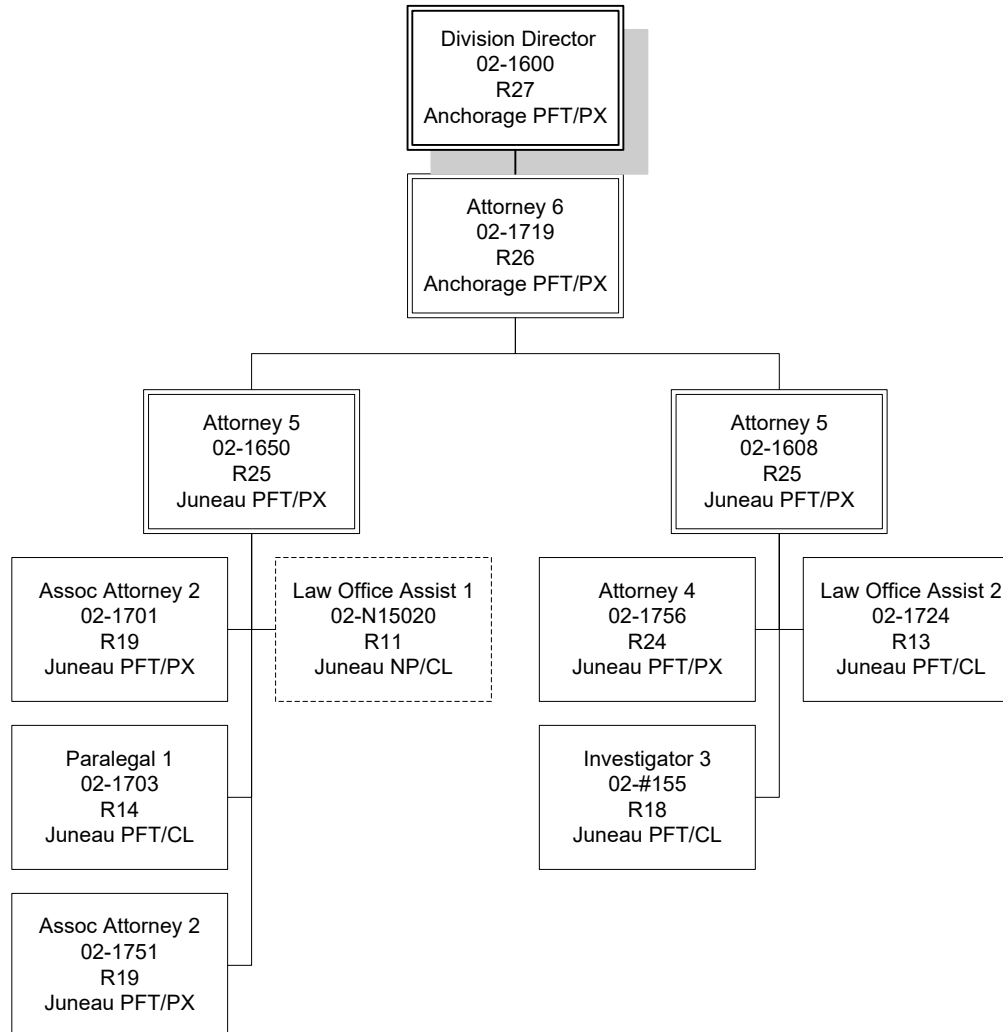

Department of Administration
Office of Public Advocacy (43)
Kenai Criminal and Parental Representation

