

State of Alaska
FY2024 Governor's Operating Budget

Department of Health
Senior and Disabilities Services Administration
Component Budget Summary

Component: Senior and Disabilities Services Administration**Contribution to Department's Mission**

Provide administrative and logistics support and services to division leadership and program staff as well as provide oversight of grant and Medicaid waiver programs for Alaska's seniors and disabled.

Core Services

- Provide administrative, fiscal, program, and logistical support and services to the Division of Senior and Disabilities Services staff.
- Determine program eligibility for Medicaid waiver and personal care assistance services as well as nursing home authorizations and transitions.
- Oversee quality assurance, adult protective services, technical assistance, crisis management, and care coordination.
- Work with division and outside agency personnel to determine policy governing the planning and implementation of services and supports for Alaskans with physical and/or developmental disabilities, aging Alaskans, children with complex medical conditions, Alaskans with traumatic brain injuries or Alzheimer's disease and related disorders, and infants 0-3 with developmental delay.
- Provide guidance in procurement, development, and management of contracts and grants for community-based services, accounting, payroll, and personnel supporting division activity.
- Conduct thorough research and analysis of program data to complete required reports, and to provide factual support of management decisions for the division's various programs and activities.
- Develop the division's annual budget, legislative position papers, fiscal notes, briefing documents, and budget materials for the division's programs and components.

Major Component Accomplishments in 2022

- Senior and Disabilities Services staff assisted recipients and providers of services with guidance and support as the COVID-19 pandemic persisted through FY2022. The federally approved flexibilities through federal Appendix K and 1135 authorities remained in place through FY2022. Changes to regulations were made to make some service flexibilities permanent after the public health emergency has ended.
- Additional regulations projects completed in FY2022 were Employment Services and Provider Certification Updates.
- The division supported a total of 4,892 people in receipt of services through the five Home and Community Based Waivers.
- The division supported 2,904 people to receive supports through Community First Choice and State Plan Personal Care Services.
- Late in FY2021, Congress passed the American Rescue Plan Act (ARPA), which included a provision for states to apply for and receive an enhanced Federal Medical Assistance Percentage in exchange for improvements to the state's home and community-based services. The division embarked on two approved plans (1) to reimburse service providers for COVID-19 and workforce related expenditures including recruitment and retention bonuses, COVID-19 related overtime, and personal protective equipment. The division has paid out close to \$7 million to service providers to date. (2) The division is working alongside the Center for Human Development on a direct support professional training certification program pilot. This pilot was recently launched, and it is hoped it will lead to increased direct support professional retention and job satisfaction.
- In February 2022, the state's electronic visit verification system was certified by the Centers for Medicare and Medicaid Services (CMS). Certification is a critical requirement for state Medicaid agencies to receive reimbursement for implementation and operational costs associated with Electronic Visit Verification. Alaska is on track to meet the federal deadline for home health care services electronic visit verification implementation by January 1, 2023, without requesting a one-year good faith effort extension.

- The division received funding from the Mental Health Trust Authority to hire a care coordinator liaison and support staff. This staff is working closely to strengthen the communication between the division and community care coordinators through “open hours,” technical assistance, information sharing, and problem solving.
- Division staff worked closely with the Office of Rate Review on rate rebasing home and community based services and state plan providers this year. Regulations are currently out for public comment.
- Division staff participated in the Dementia Action Collaborative which published a resource guide for caregivers of people who experience dementia and Alzheimer’s disease.
- The Central Intake Unit received and processed 34,880 reports in FY2022. This number has steadily grown over the past few years, which is evidence of successful outreach and training to providers and communities on the importance of timely reporting and mandated reporting. Reports resulted in 281 investigations conducted by the Quality Assurance Unit, 2,626 investigations conducted by Adult Protective Services, and referrals to Health Care Services for Residential Licensing Investigations.
- The Adult Protective Services Unit launched three new assessment tools this year to better inform investigations and outcomes: a screening assessment, a safety assessment, and a strength and needs assessment.

Key Component Challenges

- Agencies and individuals providing home and community-based services report that workforce shortages and staffing needs are the most severe they have seen. Care coordinators have steadily decreased in number over the past several years. Agencies employing direct services professionals, who work in assisted living homes, provide personal care services, offer respite to family caregivers, and perform other direct tasks, are reporting increasing turnover and challenges in recruitment that are leaving many vulnerable Alaskans without these critical supports and ultimately more likely to need higher levels of care. Throughout the federal public health emergency, family members or those with a legal duty to support have been allowed to be paid caregivers, however once the public health emergency is over, that provision will expire and the need for direct care professionals will be acute.
- Growth in Alaska’s population aged 60 and older is continuing, with the fastest growth among those aged 80 and older. Alaska has one of the top growth rates in the United States for the senior population, as Alaska is experiencing twice the national growth rate. Planning for greater capacity and infrastructure across the spectrum of senior services, including home and community-based services as well as long-term care, is critical, especially to ensure that older seniors and those with dementia will have the care they need.
- Alaska continues to be challenged in meeting the service needs for individuals with complex behaviors who also have disabilities. Such individuals have long-term support and service needs that are not appropriately met in hospitals or correctional facilities; yet Alaska’s communities lack the housing, staffing, and other infrastructure that can help them live in homes where they, their families, and neighbors can be assured of safety and health.
- The division is developing a plan to eliminate the waitlist for the Intellectual and Developmental Disabilities Waiver and to prevent future waitlists from occurring. The Individualized Supports Waiver is also nearing capacity and will be included in a plan to eliminate both over a five-year period. The plan is due to the legislature by December 20, 2022.

Significant Changes in Results to be Delivered in FY2024

- The Critical Incident Trending and Analysis system that will allow the state to use data-mining techniques to proactively identify unreported and underreported critical incidents and trends in critical incidents (those that jeopardize the health and safety of service recipients) will be implemented in spring 2023. Identifying potential incidents in this way is expected to lead to a more targeted and systemic approach to preventing future incidents from occurring.
- In FY2022 the division received notice that it had been awarded technical assistance from the National Center on Advancing Person-Centered Practices and Systems to help build the state’s person-centered vision, planning, and practice to support people with disabilities and older adults with long-term service and support needs. The division anticipates that recommendations from this technical assistance will point the way toward needed changes to better align with the “shared vision” for individuals with developmental disabilities embedded in Alaska statute in 2018, in which each person directs their own

supports, based on their strengths and abilities, toward a meaningful life in their homes, jobs, and communities.

- The division is working with the Division of Health Care Services to implement electronic visit verification for home health services by January 2, 2023.
- In FY2023 the division is implementing a new learning management system to better serve direct service professionals, program administrators, and others who need to have evidence of training and credentialing. With the advent of the new system, providers will be able to track and monitor their learning needs and have more flexibility in accessing courses. Training highly qualified direct support professionals and paraprofessionals remains a core tenet of building, enhancing, and sustaining the division's early intervention and home and community based systems. Senior and Disabilities Services also hopes the learning management system can eventually be accessed by families and the individuals who receive services.

Statutory and Regulatory Authority

AS 44.29.020	State Government; Department of Health
AS 47.24	Welfare, Social Services, and Institutions; Protection of Vulnerable Adults
AS 47.33	Welfare, Social Services, and Institutions; Assisted Living Homes
AS 47.65	Welfare, Social Services, and Institutions; Service Programs for Older Alaskans and Other Adults
AS 47.80	Welfare, Social Services, and Institutions; Persons with Disabilities
7 AAC 43	Medical Assistance
7 AAC 72	Civil Commitment
7 AAC 78	Grant Programs
PL 98-459	Public Law, Title III Older Americans Act, as Amended
42 CFR, Part 440	Public Health; Medical Assistance Programs
45 CFR, Part 1321	Public Welfare; Grants to State and Community Programs on Aging

Contact Information
<p>Contact: Sylvan Robb, Division Director Phone: (907) 465-1630 E-mail: sylvan.robbs@alaska.gov</p>

Senior and Disabilities Services Administration Personal Services Information				
Authorized Positions			Personal Services Costs	
	FY2023 Management Plan	FY2024 Governor		
Full-time	163	163	Annual Salaries	12,971,145
Part-time	0	0	COLA	354,767
Nonpermanent	5	5	Premium Pay	0
			Annual Benefits	8,060,173
			<i>Less 4.41% Vacancy Factor</i>	<i>(942,185)</i>
			Lump Sum Premium Pay	0
Totals	168	168	Total Personal Services	20,443,900

Position Classification Summary					
Job Class Title	Anchorage	Fairbanks	Juneau	Others	Total
Accountant 3	0	0	1	0	1
Administrative Assistant 2	2	0	1	0	3
Administrative Officer 1	1	0	0	0	1
Administrative Officer 2	0	0	1	0	1
Admn OPS Mgr 2	0	0	1	0	1
Division Director - Px	1	0	0	0	1
Division Operations Manager	0	0	1	0	1
Health Program Associate	3	0	0	0	3
Health Program Manager 1	16	1	0	0	17
Health Program Manager 2	41	3	7	0	51
Health Program Manager 3	6	0	2	0	8
Health Program Manager 4	2	1	0	0	3
Medicaid Program Specialist 1	7	0	0	0	7
Medicaid Program Specialist 3	6	0	0	0	6
Medicaid Program Specialist 4	1	0	0	0	1
Nurse 2	6	0	0	0	6
Nurse 3	1	0	0	0	1
Office Assistant 1	1	0	0	0	1
Office Assistant 2	9	0	0	0	9
Pro Svcs Sp 2	6	0	0	0	6
Pro Svcs Sp 3	9	2	1	0	12
Pro Svcs Sp 4	2	1	0	0	3
Program Coordinator 1	1	0	1	0	2
Project Assistant	2	0	0	0	2
Protective Services Manager 1	1	0	0	0	1
Research Analyst 1	1	0	0	0	1
Research Analyst 3	2	0	0	0	2
Research Analyst 4	1	1	0	0	2
Senior Services Technician	11	0	0	0	11
Training Specialist 1	1	0	0	0	1
Training Specialist 2	2	0	0	0	2
Training Specialist 3	1	0	0	0	1
Totals	143	9	16	0	168

Component Detail All Funds
Department of Health

Component: Senior and Disabilities Services Administration (2663)
RDU: Senior and Disabilities Services (487)

Non-Formula Component

	FY2022 Actuals	FY2023 Conference Committee	FY2023 Authorized	FY2023 Management Plan	FY2024 Governor	FY2023 Management Plan vs FY2024 Governor	
71000 Personal Services	19,542.8	19,996.7	20,005.4	20,005.4	20,443.9	438.5	2.2%
72000 Travel	67.0	371.2	371.2	344.8	347.2	2.4	0.7%
73000 Services	5,522.9	4,505.7	4,505.7	4,532.1	4,681.6	149.5	3.3%
74000 Commodities	313.2	187.0	187.0	187.0	182.6	-4.4	-2.4%
75000 Capital Outlay	156.0	332.5	332.5	332.5	332.5	0.0	0.0%
77000 Grants, Benefits	0.0	0.0	0.0	0.0	0.0	0.0	0.0%
78000 Miscellaneous	0.0	0.0	0.0	0.0	0.0	0.0	0.0%
Totals	25,601.9	25,393.1	25,401.8	25,401.8	25,987.8	586.0	2.3%
Fund Sources:							
1002 Fed Rcpts (Fed)	11,764.9	0.0	0.0	0.0	0.0	0.0	0.0%
1003 G/F Match (UGF)	11,189.8	0.0	0.0	0.0	0.0	0.0	0.0%
1007 I/A Rcpts (Other)	245.4	0.0	0.0	0.0	0.0	0.0	0.0%
1037 GF/MH (UGF)	1,558.6	0.0	0.0	0.0	0.0	0.0	0.0%
1061 CIP Rcpts (Other)	616.0	0.0	0.0	0.0	0.0	0.0	0.0%
1092 MHTAAR (Other)	227.2	0.0	0.0	0.0	0.0	0.0	0.0%
1002 Fed Rcpts (Fed)	0.0	12,643.6	12,647.9	12,647.9	13,012.9	365.0	2.9%
1003 G/F Match (UGF)	0.0	9,949.9	9,954.3	9,954.3	10,210.1	255.8	2.6%
1007 I/A Rcpts (Other)	0.0	899.3	899.3	899.3	909.6	10.3	1.1%
1037 GF/MH (UGF)	0.0	1,605.5	1,605.5	1,605.5	1,561.9	-43.6	-2.7%
1092 MHTAAR (Other)	0.0	294.8	294.8	294.8	293.3	-1.5	-0.5%
Unrestricted General (UGF)	12,748.4	11,555.4	11,559.8	11,559.8	11,772.0	212.2	1.8%
Designated General (DGF)	0.0	0.0	0.0	0.0	0.0	0.0	0.0%
Other Funds	1,088.6	1,194.1	1,194.1	1,194.1	1,202.9	8.8	0.7%
Federal Funds	11,764.9	12,643.6	12,647.9	12,647.9	13,012.9	365.0	2.9%
Positions:							
Permanent Full Time	163	163	163	163	163	0	0.0%
Permanent Part Time	0	0	0	0	0	0	0.0%
Non Permanent	8	8	8	5	5	0	0.0%

Change Record Detail - Multiple Scenarios with Descriptions
Department of Health

Component: Senior and Disabilities Services Administration (2663)

RDU: Senior and Disabilities Services (487)

Scenario/Change Record Title	Trans Type	Totals	Personal Services	Travel	Services	Commodities	Capital Outlay	Grants, Benefits	Miscellaneous	Positions		NP
										PFT	PPT	
***** Changes From FY2023 Conference Committee To FY2023 Authorized *****												
FY2023 Conference Committee												
	ConfCom	25,393.1	19,996.7	371.2	4,505.7	187.0	332.5	0.0	0.0	163	0	8
1002 Fed Rcpts		12,643.6										
1003 G/F Match		9,949.9										
1007 I/A Rcpts		899.3										
1037 GF/MH		1,605.5										
1092 MHTAAR		294.8										
FY2023 Exempt 5% COLA												
	SalAdj	8.7	8.7	0.0	0.0	0.0	0.0	0.0	0.0	0	0	0
1002 Fed Rcpts		4.3										
1003 G/F Match		4.4										
FY2023 Exempt 5% COLA: \$8.7												
Subtotal		25,401.8	20,005.4	371.2	4,505.7	187.0	332.5	0.0	0.0	163	0	8
***** Changes From FY2023 Authorized To FY2023 Management Plan *****												
Align Authority with Anticipated Expenditures												
	LIT	0.0	0.0	-26.4	26.4	0.0	0.0	0.0	0.0	0	0	0
Transfer authority from travel to cover anticipated services costs. The remaining travel authority is sufficient to cover anticipated expenditures.												
Delete Non-Permanent Health Prog Mgr 2 (06-N18002), Research Analyst 2 (06-N20019), and Medicaid Prog Spec 1 (06-N16006)												
	PosAdj	0.0	0.0	0.0	0.0	0.0	0.0	0.0	0.0	0	0	-3
Delete a long-term vacant non-permanent, range 19, Health Program Manager 2 (06-N18002) in Anchorage.												
Delete a non-permanent Research Analyst 2 (06-N20019), range 16, located in Anchorage due to the completion of an adult protective services project that was the sole focus of this position.												
Delete a non-permanent Medicaid Program Specialist 1 (06-N16006), range 16, located in Anchorage. The responsibilities of this position will now be performed by the telehealth coordinator, a full-time Medicaid Program Specialist 2 (16-#117), range 18, located in Anchorage.												
Subtotal		25,401.8	20,005.4	344.8	4,532.1	187.0	332.5	0.0	0.0	163	0	5
***** Changes From FY2023 Management Plan To FY2024 Governor *****												
Transfer from Administrative Support Services for FY2023 Unallocated Rates Adjustment												
	Trin	213.2	0.0	0.0	213.2	0.0	0.0	0.0	0.0	0	0	0
1002 Fed Rcpts		142.8										

Change Record Detail - Multiple Scenarios with Descriptions
Department of Health

Component: Senior and Disabilities Services Administration (2663)

RDU: Senior and Disabilities Services (487)

Scenario/Change Record Title	Trans Type	Totals	Personal Services	Travel	Services	Commodities	Capital Outlay	Grants, Benefits	Miscellaneous	Positions		NP
										PFT	PPT	
1003 G/F Match		70.4										

In FY2023, the unallocated rates adjustment was distributed throughout the department to the divisions that will use the fund sources. Departmental Support Services used the federal receipts and general fund match to reduce chargebacks to the divisions in FY2023 and is allocating that authority to the divisions in FY2024.

The total amount allocated to Departmental Support Services; Administrative Support Services for FY2023 was:

- \$984.4 Federal Receipts -- Departmental Support Services; Administrative Support Services
- \$492.0 GF Match -- Departmental Support Services; Administrative Support Services

The FY2023 unallocated rates adjustment will be allocated in FY2024 as follows:

- \$140.1 total -- \$93.8 Federal -- \$46.3 GF Match -- Behavioral Health, Behavioral Health Administration
- \$142.1 total -- \$95.2 Federal -- \$46.9 GF Match -- Health Care Services, Medical Assistance Administration
- \$483.9 total -- \$324.2 Federal -- \$159.7 GF Match -- Public Assistance, Public Assistance Field Services
- \$340.8 total -- \$228.3 Federal -- \$112.5 GF Match -- Public Health, Public Health Administrative Services
- \$213.2 total -- \$142.8 Federal -- \$70.4 GF Match -- Senior and Disability Services, Senior and Disability Services Administration
- \$156.3 total -- \$100.1 Federal -- \$56.2 GF Match -- Departmental Support Services, Administrative Support Services

Reverse MH Trust: Develop Targeted Outcome Data

	OTI	Totals	Personal Services	Travel	Services	Commodities	Capital Outlay	Grants, Benefits	Miscellaneous	PFT	PPT	NP
1092 MHTAAR		-80.0	0.0	0.0	-80.0	0.0	0.0	0.0	0.0	0	0	0

The implementation of National Core Indicators will be advanced. These National Core Indicators represent a major effort among states to standardize the collection of performance and outcome measures for home and community-based services. Standard data collection allows states to compare results and provides data for the establishment of national benchmarks. Data is gathered from a variety of surveys directed at consumers, families, and providers and is frequently used as part of quality assurance programs for Home and Community Based Services waivers. Including Alaska, 46 other states participate in the National Core Indicator program.

Reverse MH Trust: Protective Services Specialist 3 for Institutional Discharge Planning

	OTI	Totals	Personal Services	Travel	Services	Commodities	Capital Outlay	Grants, Benefits	Miscellaneous	PFT	PPT	NP
1092 MHTAAR		-75.0	-65.0	0.0	-10.0	0.0	0.0	0.0	0.0	0	0	0

This will be a dedicated position responsible for assisting with institutional discharge planning from hospitals, Department of Corrections, the Alaska Psychiatric Institute, and petitions for guardianship, which will significantly improve discharge planning.

Reverse MH Trust: Research and Capacity Improvements: InterRAI

	OTI	Totals	Personal Services	Travel	Services	Commodities	Capital Outlay	Grants, Benefits	Miscellaneous	PFT	PPT	NP
1092 MHTAAR		-55.3	-55.3	0.0	0.0	0.0	0.0	0.0	0.0	0	0	0

Senior and Disabilities Services (SDS) will dedicate positions to include a Medicaid program specialist and research assistant as part of a system operations team. This team will help manage the implementation and integration of a new consumer assessment and resource allocation tool. Additional staff are necessary to incorporate use of these tools in the division processes and the existing case management system. This team will ensure the division can evaluate the tools

Change Record Detail - Multiple Scenarios with Descriptions
Department of Health

Component: Senior and Disabilities Services Administration (2663)

RDU: Senior and Disabilities Services (487)

Scenario/Change Record Title	Trans Type	Totals	Personal Services	Travel	Services	Commodities	Capital Outlay	Grants, Benefits	Miscellaneous	Positions		NP
										PFT	PPT	
effectively and use data to improve services. Implementing a new consumer assessment and resource allocation tool will allow the division to improve the benefit determination and service planning process for home and community-based services.												
Reverse MH Trust: Rural Home and Community-Based Services Coordinator												
1092 MHTAAR	OTI	-81.0	-71.0	-5.0	0.0	-5.0	0.0	0.0	0.0	0	0	0
The Rural Home and Community Based Services (HCBS) Coordinator will engage in a comprehensive and coordinated approach to long-term care development for seniors that addresses the serious infrastructure gaps in Alaska's smaller communities and rural villages. The goal is to assist with the development of sufficient home and community-based services so Mental Health Trust beneficiaries do not have to leave their community when they have extensive care needs their families cannot provide. The incumbent in this position will provide outreach, education, and intensive community-based technical assistance work to assist in meeting the needs of people with Alzheimer's disease, related dementias, and other related cognitive disabling conditions, as well as with elders with co-occurring behavioral health conditions and/or addictions.												
Reverse MH Trust: IT Application/Telehealth Service System Improvements												
1037 GF/MH	OTI	-63.0	0.0	0.0	-63.0	0.0	0.0	0.0	0.0	0	0	0
Senior and Disabilities Services (SDS) will dedicate a full-time staff member to the telehealth project to support operating infrastructure. Individuals who receive personal care assistance or Medicaid waiver services require an annual reassessment conducted by a SDS nurse assessor to continue being eligible for services. Service recipients who live outside of the regional hub communities can experience difficulties getting timely assessments due to staff availability, weather, flight schedules, unexpected travel, individual medical needs, or other unexpected events. Delayed assessments are inefficient and can result in higher costs associated with travel and rescheduling. Through telehealth, reassessments are conducted with the individual service recipient participating at their local clinic through collaboration with the regional health organization. This position will explore the possibility of other services or functions using telehealth to meet with individuals, family, or community members to improve access and timeliness of receiving services. Telehealth increases access to services through timely assessments, internal efficiencies, and ability to shift high travel costs.												
Reverse FY2023 GGU COLA & HI Increase												
1092 MHTAAR	OTI	-3.1	-3.1	0.0	0.0	0.0	0.0	0.0	0.0	0	0	0
Reverse Mental Trust Authority Authorized Receipts for FY2023 GGU 3% COLA & \$12.50 HI Increase: -\$3.1												
Reverse FY2023 General Government Unit SBS and Risk Management Rate Changes												
1092 MHTAAR	OTI	-0.4	-0.4	0.0	0.0	0.0	0.0	0.0	0.0	0	0	0
Reverse Mental Trust Authority Authorized Receipts for FY2023 Change General Government Unit (GG, GP, GY, GZ) - SBS, and Risk Management Rates: -0.4												
FY2024 PERS Rate Adjustment												
1002 Fed Rcpts	SalAdj	19.1	37.8	0.0	0.0	0.0	0.0	0.0	0.0	0	0	0

Change Record Detail - Multiple Scenarios with Descriptions
Department of Health

Component: Senior and Disabilities Services Administration (2663)

RDU: Senior and Disabilities Services (487)

Scenario/Change Record Title	Trans Type	Totals	Personal Services	Travel	Services	Commodities	Capital Outlay	Grants, Benefits	Miscellaneous	Positions		NP
										PFT	PPT	
1003 G/F Match		16.3										
1007 I/A Rcpts		0.7										
1037 GF/MH		1.7										
FY2024 PERS rate adjustment to 25.10%: \$37.8												
FY2024 Salary and Health Insurance Increases												
	SalAdj	400.3	400.3	0.0	0.0	0.0	0.0	0.0	0.0	0	0	0
1002 Fed Rcpts		202.5										
1003 G/F Match		168.5										
1007 I/A Rcpts		9.6										
1037 GF/MH		17.7										
1092 MHTAAR		2.0										
FY2024 Salary and Health Insurance Increases: \$400.3												
FY2024 GGU cost of living increase 2.5%: \$299.6												
FY2024 SU cost of living increase 1%: \$46.7												
FY2024 AlaskaCare insurance from \$1,685 to \$1,793 per member per month.: \$44.8												
FY2024 GGU health insurance increase from \$1,567.50 to \$1,573.50 per member per month.: \$9.2												
FY2024 AlaskaCare Health Insurance Increase - Exempt and Partially Exempt												
	SalAdj	1.2	1.2	0.0	0.0	0.0	0.0	0.0	0.0	0	0	0
1002 Fed Rcpts		0.6										
1003 G/F Match		0.6										
FY2024 AlaskaCare health insurance increase for exempt and partially exempt employees from \$1,685 to \$1,793 per member per month.: \$1.2												
MH Trust: Develop Targeted Outcome Data (FY18-FY25)												
	IncT	80.0	0.0	0.0	80.0	0.0	0.0	0.0	0.0	0	0	0
1092 MHTAAR		80.0										

The Department of Health, Division of Senior and Disabilities Services will use these funds to advance the state's implementation and use of the National Core Indicators. The National Core Indicators represents a major effort among states to standardize the collection of performance and outcome measures for home and community-based services. Standard data collection allows states to compare results with other states and provides data for the establishment of national benchmarks. Data is gathered from a variety of surveys directed at consumers, families, and providers and is frequently used as part of quality assurance programs for home and community-based services waivers.

MH Trust: Adult Protective Services 3 (FY21-FY25)

Change Record Detail - Multiple Scenarios with Descriptions
Department of Health

Component: Senior and Disabilities Services Administration (2663)

RDU: Senior and Disabilities Services (487)

Scenario/Change Record Title	Trans Type	Totals	Personal Services	Travel	Services	Commodities	Capital Outlay	Grants, Benefits	Miscellaneous	Positions		
										PFT	PPT	NP
1092 MHTAAR	IncT	75.0	73.0	1.0	1.0	0.0	0.0	0.0	0.0	0	0	0
<p>The Adult Protective Services (APS) 3 position supports state operating infrastructure. This position is dedicated to coordinating with the discharge planning teams from medical hospitals, the Alaska Psychiatric Institute, and the Department of Corrections to improve the institutional or inpatient discharge process. The Adult Protective Services 3 will assist the discharge teams with petitions for guardianship for people who lack the capacity to make their own decisions and need the support of a guardian to successfully return to the community.</p>												
MH Trust: Care Coordination Support (FY22-FY25)												
1092 MHTAAR	IncT	55.3	45.9	2.4	6.7	0.3	0.0	0.0	0.0	0	0	0
<p>Care Coordination Support provides funding toward the Care Coordination Liaison position at Senior and Disabilities Services (SDS) supporting state operating infrastructure. The goal of this project is to assist with the support and development of care coordination services, so Trust beneficiaries have access to home and community-based services. The Care Coordination Liaison will provide outreach, education, and technical assistance to support care coordinators. This position will help care coordinators navigate quality assurance, the Harmony database, the 1115 waiver services, support planning, and other direct service or administrative support needs. This position will work with SDS to identify opportunities to improve the establishment of care coordinators in rural Alaska, assist with gathering the information needed to evaluate a rate increase for this service, and other system changes that can improve the care coordination service.</p>												
MH Trust: Rural Home and Community-Based Services Coordinator (FY21-FY25)												
1092 MHTAAR	IncT	81.0	75.1	4.0	1.6	0.3	0.0	0.0	0.0	0	0	0
<p>The Rural Home and Community Based Services (HCBS) Coordinator supports state operating infrastructure. The coordinator position will engage in a comprehensive and coordinated approach to long-term care development for seniors and people with disabilities that address the serious infrastructure gaps in Alaska's smaller communities and rural villages. The goal is to assist with the development of sufficient home and community-based services so Trust beneficiaries do not have to leave their community when they have extensive care needs their families cannot provide. The incumbent in this position will provide outreach, education, and intensive community-based technical assistance work to assist in meeting the needs of people with Alzheimer's disease and related dementias and other related cognitive disabling conditions, as well as with elders with co-occurring behavioral health conditions and/or addictions.</p>												
Totals		25,987.8	20,443.9	347.2	4,681.6	182.6	332.5	0.0	0.0	163	0	5

Line Item Detail (1676)
Department of Health & Social Services
Travel

Component: Senior and Disabilities Services Administration (2663)

Line Number	Line Name		FY2022 Actuals	FY2023 Management Plan	FY2024 Governor
2000	Travel		67.0	0.0	0.0
Object Class	Servicing Agency	Explanation	FY2022 Actuals	FY2023 Management Plan	FY2024 Governor
2000 Travel Detail Totals			67.0	0.0	0.0
2000	In-State Employee Travel	In-state travel costs for administrative purposes and for division staff to attend departmental meetings and briefings, monitor and evaluate grantee services, attend conferences and training. Field travel costs for program staff to visit provider agencies to provide technical assistance and oversight of state and federal programs for Alaska beneficiaries.	59.4	0.0	0.0
2001	In-State Non-Employee Travel	In-state non-employee travel for Adult Protective Services clients.	3.5	0.0	0.0
2002	Out of State Employee Travel	Out-of-state travel for administrative purposes and for division staff to attend meetings and training as required.	4.1	0.0	0.0

Line Item Detail (1676)
Department of Health & Social Services
Services

Component: Senior and Disabilities Services Administration (2663)

Line Number	Line Name		FY2022 Actuals	FY2023 Management Plan	FY2024 Governor
3000	Services		5,522.9	0.0	0.0
Object Class	Servicing Agency	Explanation	FY2022 Actuals	FY2023 Management Plan	FY2024 Governor
3000 Services Detail Totals			5,522.9	0.0	0.0
3000	Education Services	Training, educational conferences, agency memberships, tuition, books and fees for work-related courses.	32.8	0.0	0.0
3001	Financial Services	State Travel Office fees, accounting, auditing, management consulting and grantee monitoring.	11.9	0.0	0.0
3003	Information Technology	Software licensing renewal and maintenance costs including Harmony, Thread, Brookes Publishing, Zoom, Survey Monkey, LogMe In.	718.1	0.0	0.0
3004	Telecommunications	Communication costs to outside vendors for long distance charges, teleconference fees, data circuits, television, cellular and other wireless phone costs.	44.4	0.0	0.0
3006	Delivery Services	Delivery costs to include postage for the division's mail outs (including mass mail out prepaid envelopes for clients), freight, and messenger or courier delivery costs.	35.6	0.0	0.0
3007	Advertising and Promotions	Advertising, printing, and binding costs.	15.5	0.0	0.0
3008	Utilities	Waste disposal costs incurred to destroy confidential records. Recycling and other assorted utility costs.	4.0	0.0	0.0
3009	Structure/Infrastructure/Land	Architect/Engineer services related	175.9	0.0	0.0

Line Item Detail (1676)
Department of Health & Social Services
Services

Component: Senior and Disabilities Services Administration (2663)

Object Class	Servicing Agency	Explanation	FY2022 Actuals	FY2023 Management Plan	FY2024 Governor
3000 Services Detail Totals			5,522.9	0.0	0.0
		to office move and design			
3010	Equipment/Machinery	Annual NeoPost mail machine maintenance	9.7	0.0	0.0
3011	Other Services	Various contracts: Senior and Disabilities Level of Care Reassessment Denial Reviews RMS Software Social Assistance Management System Database Harmony Administrative Support On-Demand Interpreter/Translation Services Home and Community Based Services 1915(i) and 1915(k) new assessment tool and any software changes for data management system. Senior and Disabilities Regulations Writer Home Assessments National Core Indicators Consultant Electronic Visit Verification Maintenance & Operations Home and Community Based Services Strategies Consultant Statewide Independent Living Council (SILC)	1,027.8	0.0	0.0
3017	Inter-Agency Information Technology Non-Telecommunications	Admin - Department-wide Reimbursable Services Agreement Department of Administration, Office of Information Technology Core Services Chargeback includes Computer Resources Enterprise Productivity Rate, Virtual Private Network telecommunications, Computer Resources, select Adobe licensing, select Microsoft licensing,	572.5	0.0	0.0

Line Item Detail (1676)
Department of Health & Social Services
Services

Component: Senior and Disabilities Services Administration (2663)

Object Class	Servicing Agency	Explanation	FY2022 Actuals	FY2023 Management Plan	FY2024 Governor
3000 Services Detail Totals			5,522.9	0.0	0.0
		other software costs.			
3018	Inter-Agency Information Technology Telecommunications	Admin - Department-wide Reimbursable Services Agreement Department of Administration, Office of Information Technology Microsoft Exchange.	83.8	0.0	0.0
3021	Inter-Agency Mail	Admin - Department-wide Reimbursable Services Agreement Department of Administration, postage, and mail service costs.	1.1	0.0	0.0
3022	Inter-Agency Human Resources	Admin - Department-wide Reimbursable Services Agreement Department of Administration, Administrative Services Division, Human Resource Services. The cost to provide standardized, consistent, and quality services in all areas of human resource services.	103.5	0.0	0.0
3023	Inter-Agency Building Leases	Trans - Department-wide	859.9	0.0	0.0
3024	Inter-Agency Legal	Law - Department-wide Reimbursable Services Agreement Department of Law, Civil Division, Regulation Review, Legal Services Costs for review and transmittal of administrative regulations	2.5	0.0	0.0
3026	Inter-Agency Insurance	Admin - Department-wide Reimbursable Services Agreement Department of Administration, Risk Management.	22.3	0.0	0.0
3027	Inter-Agency Financial	Admin - Department-wide Inter-agency financial services	2.1	0.0	0.0
3028	Inter-Agency Americans with Disabilities Act Compliance	Admin - Department-wide Reimbursable Services Agreement Department of Administration, Americans with Disabilities Act chargeback. Cost incurred to comply with the Americans with Disabilities Act to ensure services, programs, and activities are readily accessible to and usable by individuals with disabilities.	1.7	0.0	0.0

Line Item Detail (1676)
Department of Health & Social Services
Services

Component: Senior and Disabilities Services Administration (2663)

Object Class		Servicing Agency	Explanation	FY2022 Actuals	FY2023 Management Plan	FY2024 Governor
3000 Services Detail Totals				5,522.9	0.0	0.0
3029	Inter-Agency Education/Training	H&SS - Commission on Aging (2674)	Reimbursable Services Agreement with Alaska Commission on Aging	191.9	0.0	0.0
3030	Inter-Agency Hearing/Mediation	Admin - Department-wide	Reimbursable Services Agreement Department of Administration, Centralized Administrative Services, Hearing Officer Services for Senior and Disabilities Services.	2.5	0.0	0.0
3032	Inter-Agency Health	H&SS - Governor's Cncl/Disabilities (2023)	Reimbursable Services Agreement Division of Senior and Disabilities Administration for the Interagency Coordinating Council reimbursable services agreement.	100.0	0.0	0.0
3032	Inter-Agency Health	Rev - Department-wide	Reimbursable Services Agreement Department of Revenue, Alaska Mental Health Trust Authority, Long Term Ombudsman Office. Costs incurred to administer the Long Term Ombudsman Care office.	475.6	0.0	0.0
3032	Inter-Agency Health	Univ - Department-wide	Reimbursable Services Agreement with the University of Alaska	232.3	0.0	0.0
3037	State Equipment Fleet	Trans - Department-wide	Department of Transportation and Public Facilities, State Equipment Fleet services.	31.0	0.0	0.0
3038	Inter-Agency Management/Consulting	H&SS - Information Technology Services (2754)	Reimbursable Services Agreement Department Wide, Infant Learning Program Application, Unique Object Framework Eradication	764.5	0.0	0.0

Line Item Detail (1676)
Department of Health & Social Services
Commodities

Component: Senior and Disabilities Services Administration (2663)

Line Number	Line Name		FY2022 Actuals	FY2023 Management Plan	FY2024 Governor
4000	Commodities		313.2	0.0	0.0
Object Class	Servicing Agency	Explanation	FY2022 Actuals	FY2023 Management Plan	FY2024 Governor
		4000 Commodities Detail Totals	313.2	0.0	0.0
4000	Business	General office supplies necessary to support programs and activities. Includes educational materials, duplicating, copying and information technology supplies. Also includes office and computer equipment, furniture and tools with a cost or value of less than \$5,000.	313.2	0.0	0.0

Line Item Detail (1676)
Department of Health & Social Services
Capital Outlay

Component: Senior and Disabilities Services Administration (2663)

Line Number	Line Name		FY2022 Actuals	FY2023 Management Plan	FY2024 Governor
5000	Capital Outlay		156.0	0.0	0.0
Object Class	Servicing Agency	Explanation	FY2022 Actuals	FY2023 Management Plan	FY2024 Governor
5000 Capital Outlay Detail Totals			156.0	0.0	0.0
5004	Equipment	Information technology costs related to database system implementation maintenance and operations.	156.0	0.0	0.0

Line Item Detail (1676)
Department of Health
Travel

Component: Senior and Disabilities Services Administration (2663)

Line Number	Line Name		FY2022 Actuals	FY2023 Management Plan	FY2024 Governor
2000	Travel		0.0	344.8	347.2
Object Class	Servicing Agency	Explanation	FY2022 Actuals	FY2023 Management Plan	FY2024 Governor
2000 Travel Detail Totals			0.0	344.8	347.2
2000	In-State Employee Travel	In-state travel costs for administrative purposes and for division staff to attend departmental meetings and briefings, monitor and evaluate grantee services, attend conferences and training. Field travel costs for program staff to visit provider agencies to provide technical assistance and oversight of state and federal programs for Alaska beneficiaries.	0.0	279.4	281.8
2001	In-State Non-Employee Travel	In-state non-employee travel for Adult Protective Services clients.	0.0	0.0	0.0
2002	Out of State Employee Travel	Out-of-state travel for administrative purposes and for division staff to attend meetings and training as required.	0.0	65.4	65.4

Line Item Detail (1676)
Department of Health
Services

Component: Senior and Disabilities Services Administration (2663)

Line Number	Line Name		FY2022 Actuals	FY2023 Management Plan	FY2024 Governor
3000	Services		0.0	4,532.1	4,681.6
Object Class	Servicing Agency	Explanation	FY2022 Actuals	FY2023 Management Plan	FY2024 Governor
3000 Services Detail Totals			0.0	4,532.1	4,681.6
3000	Education Services	Training, educational conferences, agency memberships, tuition, books and fees for work-related courses.	0.0	40.0	40.0
3001	Financial Services	State Travel Office fees, accounting, auditing, management consulting and grantee monitoring.	0.0	21.9	50.0
3002	Legal and Judicial Services	Fair Hearing and Mediation costs.	0.0	20.0	20.0
3003	Information Technology	Software licensing renewal and maintenance costs including Harmony, Thread, Brookes Publishing, Zoom, Survey Monkey, LogMe In.	0.0	718.1	718.1
3004	Telecommunications	Communication costs to outside vendors for long distance charges, teleconference fees, data circuits, television, cellular and other wireless phone costs.	0.0	50.0	50.0
3006	Delivery Services	Delivery costs to include postage for the division's mail outs (including mass mail out prepaid envelopes for clients), freight, and messenger or courier delivery costs.	0.0	80.0	80.0
3007	Advertising and Promotions	Advertising, printing, and binding costs.	0.0	15.0	15.0
3008	Utilities	Waste disposal costs incurred to destroy confidential records. Recycling and other assorted utility costs.	0.0	10.0	10.0

Line Item Detail (1676)
Department of Health
Services

Component: Senior and Disabilities Services Administration (2663)

Object Class		Servicing Agency	Explanation	FY2022 Actuals	FY2023 Management Plan	FY2024 Governor
			3000 Services Detail Totals	0.0	4,532.1	4,681.6
3009	Structure/Infrastructure/Land		Architect/Engineer services related to office move and design	0.0	30.0	10.0
3010	Equipment/Machinery		Annual NeoPost mail machine maintenance	0.0	10.0	10.0
3010	Equipment/Machinery		Repair and maintenance of office furniture and equipment. Reconfiguration of office space costs along with the costs associated with office copier, fax machine and other equipment maintenance agreement costs.	0.0	10.0	10.0
3011	Other Services		Various contracts: Senior and Disabilities Level of Care Reassessment Denial Reviews RMS Software Social Assistance Management System Database Harmony Administrative Support On-Demand Interpreter/Translation Services Home and Community Based Services 1915(i) and 1915(k) new assessment tool and any software changes for data management system. Senior and Disabilities Regulations Writer Home Assessments National Core Indicators Consultant Electronic Visit Verification Maintenance & Operations Home and Community Based Services Strategies Consultant Statewide Independent Living Council (SILC)	0.0	571.4	657.9

Line Item Detail (1676)
Department of Health
Services

Component: Senior and Disabilities Services Administration (2663)

Object Class		Servicing Agency	Explanation	FY2022 Actuals	FY2023 Management Plan	FY2024 Governor
3000 Services Detail Totals				0.0	4,532.1	4,681.6
3017	Inter-Agency Information Technology Non-Telecommunications	Admin - Department-wide	Reimbursable Services Agreement Department of Administration, Office of Information Technology Core Services Chargeback includes Computer Resources Enterprise Productivity Rate, Virtual Private Network telecommunications, Computer Resources, select Adobe licensing, select Microsoft licensing, other software costs.	0.0	80.0	80.0
3017	Inter-Agency Information Technology Non-Telecommunications	H&SS - Information Technology Services (2754)	Reimbursable Services Agreement Department Wide: Information Technology Network Services Chargeback	0.0	150.0	150.0
3017	Inter-Agency Information Technology Non-Telecommunications	H&SS - Information Technology Services (2754)	Reimbursable Services Agreement Department Wide: Information Technology Customer Services Chargeback	0.0	261.0	261.0
3017	Inter-Agency Information Technology Non-Telecommunications	H&SS - Information Technology Services (2754)	Reimbursable Services Agreement Department Wide: Business Apps Chargeback	0.0	183.0	183.0
3017	Inter-Agency Information Technology Non-Telecommunications	H&SS - Information Technology Services (2754)	Reimbursable Services Agreement Infant Learning Program Business Apps Chargeback	0.0	7.0	7.0
3018	Inter-Agency Information Technology Telecommunications	Admin - Department-wide	Reimbursable Services Agreement Department of Administration, Office of Information Technology Microsoft Exchange.	0.0	20.0	20.0
3020	Inter-Agency Building Maintenance	Trans - Department-wide	Reimbursable Services Agreement Department of Transportation and Public Facilities for building maintenance.	0.0	50.0	50.0
3021	Inter-Agency Mail	Admin - Department-wide	Reimbursable Services Agreement Department of Administration,	0.0	1.8	1.8

Line Item Detail (1676)
Department of Health
Services

Component: Senior and Disabilities Services Administration (2663)

Object Class	Servicing Agency	Explanation	FY2022 Actuals	FY2023 Management Plan	FY2024 Governor
3000 Services Detail Totals			0.0	4,532.1	4,681.6
		postage, and mail service costs.			
3022	Inter-Agency Human Resources	Admin - Department-wide			
		Reimbursable Services Agreement Department of Administration, Administrative Services Division, Human Resource Services. The cost to provide standardized, consistent, and quality services in all areas of human resource services.	0.0	123.0	123.0
3023	Inter-Agency Building Leases	Admin - Department-wide			
		Reimbursable Services Agreement Department of Administration, Division of General Services, Building Lease Costs:	0.0	545.1	600.0
		Anchorage Lease #2078 Fairbanks Lease #2531 Juneau Lease #4012 Anchorage Atwood Bldg.			
3024	Inter-Agency Legal	Law - Department-wide			
		Reimbursable Services Agreement Department of Law, Civil Division, Regulation Review, Legal Services Costs for review and transmittal of administrative regulations	0.0	1.6	1.6
3025	Inter-Agency Auditing	H&SS - Administrative Support Svcs (320)			
		Reimbursable Services Agreement Department Wide: Audit Support from Finance & Management Services	0.0	30.0	30.0
3026	Inter-Agency Insurance	Admin - Department-wide			
		Reimbursable Services Agreement Department of Administration, Risk Management.	0.0	24.0	24.0
3028	Inter-Agency Americans with Disabilities Act Compliance	Admin - Department-wide			
		Reimbursable Services Agreement Department of Administration, Americans with Disabilities Act chargeback. Cost incurred to comply with the Americans with Disabilities Act to ensure services, programs,	0.0	1.7	1.7

Line Item Detail (1676)
Department of Health
Services

Component: Senior and Disabilities Services Administration (2663)

Object Class	Servicing Agency	Explanation	FY2022 Actuals	FY2023 Management Plan	FY2024 Governor
3000 Services Detail Totals			0.0	4,532.1	4,681.6
		and activities are readily accessible to and usable by individuals with disabilities.			
3029	Inter-Agency Education/Training	H&SS - Commission on Aging (2674) Reimbursable Services Agreement with Alaska Commission on Aging	0.0	0.0	0.0
3030	Inter-Agency Hearing/Mediation	Admin - Department-wide Reimbursable Services Agreement Department of Administration, Centralized Administrative Services, Hearing Officer Services for Senior and Disabilities Services.	0.0	10.0	10.0
3032	Inter-Agency Health	H&SS - Commission on Aging (2674) Reimbursable Services Agreement Department of Health & Social Services, Alaska Commission on Aging, Services to Senior and Disabilities Services. Cost to provide coordinated services to seniors.	0.0	214.0	214.0
3032	Inter-Agency Health	H&SS - Governor's Cncl/Disabilities (2023) Reimbursable Services Agreement Division of Senior and Disabilities Administration for the Interagency Coordinating Council reimbursable services agreement.	0.0	100.0	100.0
3032	Inter-Agency Health	Rev - Department-wide Reimbursable Services Agreement Department of Revenue, Alaska Mental Health Trust Authority, Long Term Ombudsman Office. Costs incurred to administer the Long Term Ombudsman Care office.	0.0	498.1	498.1
3032	Inter-Agency Health	Univ - Department-wide Reimbursable Services Agreement with the University of Alaska	0.0	0.0	0.0
3036	Inter-Agency Safety	Admin - Department-wide Reimbursable Services Agreement Department of Administration, General Services Division, Parking Security Services.	0.0	0.7	0.7
3037	State Equipment Fleet	Trans - Department-wide Department of Transportation and	0.0	30.0	30.0

Line Item Detail (1676)
Department of Health
Services

Component: Senior and Disabilities Services Administration (2663)

Object Class		Servicing Agency	Explanation	FY2022 Actuals	FY2023 Management Plan	FY2024 Governor
3000 Services Detail Totals				0.0	4,532.1	4,681.6
			Public Facilities, State Equipment Fleet services.			
3038	Inter-Agency Management/Consulting	H&SS - Information Technology Services (2754)	Reimbursable Services Agreement Department Wide, Infant Learning Program Application, Unique Object Framework Eradication	0.0	35.0	35.0
3038	Inter-Agency Management/Consulting	Univ - Department-wide	Reimbursable Services Agreement University of Alaska Anchorage, Child Welfare Academy, Infant Learning Program, Professional Development In-Service Activities	0.0	150.0	150.0
3038	Inter-Agency Management/Consulting	H&SS - Administrative Support Svcs (320)	Reimbursable Services Agreement Department Wide: Finance and Management Services support	0.0	73.0	73.0
3038	Inter-Agency Management/Consulting	H&SS - Bureau of Vital Statistics (961)	Reimbursable Services Agreement Vital Statistics Data Reporting	0.0	3.0	3.0
3038	Inter-Agency Management/Consulting	H&SS - Commissioner's Office (317)	Reimbursable Services Agreement Department Wide: Commissioner's Office Services	0.0	14.0	14.0
3038	Inter-Agency Management/Consulting	H&SS - Information Technology Services (2754)	Reimbursable Services Agreement Department of Health and Social Services, Finance and Management Services, Inter-Agency Management and Consulting Services.	0.0	24.7	24.7
3038	Inter-Agency Management/Consulting	Univ - Department-wide	Reimbursable Services Agreement University of Alaska Anchorage, Center for Human Development, Infant Learning Program, Early Intervention Research and Evaluation	0.0	120.0	120.0
3038	Inter-Agency Management/Consulting	H&SS - Public Affairs (2874)	Reimbursable Services Agreement Department Wide: Public Affairs Support	0.0	205.0	205.0

Line Item Detail (1676)
Department of Health
Commodities

Component: Senior and Disabilities Services Administration (2663)

Line Number	Line Name		FY2022 Actuals	FY2023 Management Plan	FY2024 Governor
4000	Commodities		0.0	187.0	182.6
Object Class	Servicing Agency	Explanation	FY2022 Actuals	FY2023 Management Plan	FY2024 Governor
4000 Commodities Detail Totals			0.0	187.0	182.6
4000	Business	General office supplies necessary to support programs and activities. Includes educational materials, duplicating, copying and information technology supplies. Also includes office and computer equipment, furniture and tools with a cost or value of less than \$5,000.	0.0	178.0	173.6
4002	Household/Institutional	Household and institutional supplies to include cleaning, food and nonfood supplies.	0.0	2.0	2.0
4015	Parts and Supplies	Repair and maintenance of office furniture and equipment.	0.0	7.0	7.0

Line Item Detail (1676)
Department of Health
Capital Outlay

Component: Senior and Disabilities Services Administration (2663)

Line Number	Line Name		FY2022 Actuals	FY2023 Management Plan	FY2024 Governor
5000	Capital Outlay		0.0	332.5	332.5
Object Class	Servicing Agency	Explanation	FY2022 Actuals	FY2023 Management Plan	FY2024 Governor
5000 Capital Outlay Detail Totals			0.0	332.5	332.5
5002	Structures and Infrastructure	Installation of phone/data runs	0.0	0.0	10.0
5004	Equipment	Information technology costs related to database system implementation maintenance and operations.	0.0	332.5	322.5

Revenue Detail (1681)
Department of Health & Social Services

Component: Senior and Disabilities Services Administration (2663)

Revenue Type (OMB Fund Code) Revenue Source	Component	Comment	FY2022 Actuals	FY2023 Management Plan	FY2024 Governor
5002 Fed Rcpts (1002 Fed Rcpts)			11,764.9	0.0	0.0
5006 Federal Health and Human Services - Title XIX Grants		Medicaid Administration	11,764.9	0.0	0.0
5007 I/A Rcpts (1007 I/A Rcpts)			245.4	0.0	0.0
5301 Inter-Agency Receipts	H&SS - Governor's Cncl/Disabilities (2023)	RSA: Funding for the Division of Senior and Disabilities Services to perform work related to the Governor's Council on Disabilities and Special Education Administration for Community Living - Living Well Grant.	94.2	0.0	0.0
5301 Inter-Agency Receipts	H&SS - Public Assistance Field Svc (236)	RSA: Funding for the Division of Senior and Disabilities Services to complete TEFRA Medicaid level of care decisions per 7 AAC 140.600 and 7 AAC 130.205 for TEFRA Medicaid applicants and recipients pursuing eligibility in the Intermediate Care Facility for individuals with Intellectual Disabilities (ICF/IID) level of care category.	151.2	0.0	0.0
5061 CIP Rcpts (1061 CIP Rcpts)			616.0	0.0	0.0
5351 Capital Improvement Project Inter-Agency	H&SS - Facilities Management (2020)		616.0	0.0	0.0

Revenue Detail (1681)
Department of Health

Component: Senior and Disabilities Services Administration (2663)

Revenue Type (OMB Fund Code) Revenue Source	Component	Comment	FY2022 Actuals	FY2023 Management Plan	FY2024 Governor
5002 Fed Rcpts (1002 Fed Rcpts)			0.0	12,647.9	13,012.9
5002 Federal General Government - Miscellaneous Grants		Medicare Improvements for Patients and Providers Priority 1, 2, 3	0.0	81.5	101.8
5006 Federal Health and Human Services - Title XIX Grants		Medicaid Administration	0.0	11,452.6	11,760.3
5007 Federal Health and Human Services - Miscellaneous Grants		Title III B, C1, and LTCO Administration	0.0	623.1	640.1
5007 Federal Health and Human Services - Miscellaneous Grants		Senior Medicare Patrol Admin	0.0	258.2	268.2
5007 Federal Health and Human Services - Miscellaneous Grants		State Health Insurance Assistance Program Admin	0.0	232.5	242.5
5007 I/A Rcpts (1007 I/A Rcpts)			0.0	899.3	909.6
5301 Inter-Agency Receipts		Excess Interagency Receipt Authority	0.0	634.3	644.6
5301 Inter-Agency Receipts	H&SS - Governor's Cncl/Disabilities (2023)	RSA: Funding for the Division of Senior and Disabilities Services to perform work related to the Governor's Council on Disabilities and Special Education Administration for Community Living - Living Well Grant.	0.0	100.0	100.0
5301 Inter-Agency Receipts	H&SS - Public Assistance Field Svcs (236)	RSA: Funding for the Division of Senior and Disabilities Services to complete TEFRA Medicaid level of care decisions per 7 AAC 140.600 and 7 AAC 130.205 for TEFRA Medicaid applicants and recipients pursuing eligibility in the Intermediate Care Facility for individuals with Intellectual Disabilities (ICF/IID) level of care category.	0.0	165.0	165.0
6003 G/F Match (1003 G/F Match)			0.0	9,954.3	10,210.1

Revenue Detail (1681)
Department of Health

Component: Senior and Disabilities Services Administration (2663)

Revenue Type (OMB Fund Code) Revenue Source	Component	Comment	FY2022 Actuals	FY2023 Management Plan	FY2024 Governor
6103 Match - Miscellaneous		General Fund Match	0.0	9,954.3	10,210.1
6037 GF/MH (1037 GF/MH)			0.0	1,605.5	1,561.9
6123 General Fund Mental Health - Miscellaneous		General Fund Mental Health Authority	0.0	1,605.5	1,561.9
6092 MHTAAR (1092 MHTAAR)			0.0	294.8	293.3
6691 Mental Health Trust Auth Auth Rec - Miscellaneous		Excess Mental Health Trust Authority Authorized Receipts	0.0	3.5	2.0
6691 Mental Health Trust Auth Auth Rec - Miscellaneous		Research and Capacity Improvements: InterRai	0.0	55.3	55.3
6691 Mental Health Trust Auth Auth Rec - Miscellaneous		Develop Targeted Outcome Data (National Core Indicators)	0.0	80.0	80.0
6691 Mental Health Trust Auth Auth Rec - Miscellaneous		Rural Home and Community Based Services (HCBS) Coordinator Position	0.0	81.0	81.0
6691 Mental Health Trust Auth Auth Rec - Miscellaneous		Protective Services Specialist 3 Long Term Non-Permanent Position Adult Protective Services	0.0	75.0	75.0

Inter-Agency Services (1682)
Department of Health & Social Services

Component: Senior and Disabilities Services Administration (2663)

				FY2022 Actuals	FY2023 Management Plan	FY2024 Governor
Component Totals				3,447.2	0.0	0.0
With Department of Administration				789.5	806.3	861.2
With Department of Transportation/Public Facilities				890.9	80.0	80.0
With Department of Law				2.5	1.6	1.6
With Department of Health				1,056.4	1,299.7	1,299.7
With Department of Revenue				475.6	498.1	498.1
With University of Alaska				232.3	270.0	270.0
Object Class	Servicing Agency	Explanation		FY2022 Actuals	FY2023 Management Plan	FY2024 Governor
3017	Inter-Agency Information Technology Non-Telecommunications	Admin - Department-wide	Reimbursable Services Agreement Department of Administration, Office of Information Technology Core Services Chargeback includes Computer Resources Enterprise Productivity Rate, Virtual Private Network telecommunications, Computer Resources, select Adobe licensing, select Microsoft licensing, other software costs.	572.5	0.0	0.0
3018	Inter-Agency Information Technology Telecommunications	Admin - Department-wide	Reimbursable Services Agreement Department of Administration, Office of Information Technology Microsoft Exchange.	83.8	0.0	0.0
3021	Inter-Agency Mail	Admin - Department-wide	Reimbursable Services Agreement Department of Administration, postage, and mail service costs.	1.1	0.0	0.0
3022	Inter-Agency Human Resources	Admin - Department-wide	Reimbursable Services Agreement Department of Administration, Administrative Services Division, Human Resource Services. The cost to provide standardized, consistent, and quality services in all areas of human resource services.	103.5	0.0	0.0
3023	Inter-Agency Building Leases	Trans - Department-wide		859.9	0.0	0.0

Inter-Agency Services (1682)
Department of Health & Social Services

Component: Senior and Disabilities Services Administration (2663)

Object Class		Servicing Agency	Explanation	FY2022 Actuals	FY2023 Management Plan	FY2024 Governor
3024	Inter-Agency Legal	Law - Department-wide	Reimbursable Services Agreement Department of Law, Civil Division, Regulation Review, Legal Services Costs for review and transmittal of administrative regulations	2.5	0.0	0.0
3026	Inter-Agency Insurance	Admin - Department-wide	Reimbursable Services Agreement Department of Administration, Risk Management.	22.3	0.0	0.0
3027	Inter-Agency Financial	Admin - Department-wide	Inter-agency financial services	2.1	0.0	0.0
3028	Inter-Agency Americans with Disabilities Act Compliance	Admin - Department-wide	Reimbursable Services Agreement Department of Administration, Americans with Disabilities Act chargeback. Cost incurred to comply with the Americans with Disabilities Act to ensure services, programs, and activities are readily accessible to and usable by individuals with disabilities.	1.7	0.0	0.0
3029	Inter-Agency Education/Training	H&SS - Commission on Aging (2674)	Reimbursable Services Agreement with Alaska Commission on Aging	191.9	0.0	0.0
3030	Inter-Agency Hearing/Mediation	Admin - Department-wide	Reimbursable Services Agreement Department of Administration, Centralized Administrative Services, Hearing Officer Services for Senior and Disabilities Services.	2.5	0.0	0.0
3032	Inter-Agency Health	H&SS - Governor's Cncl/Disabilities (2023)	Reimbursable Services Agreement Division of Senior and Disabilities Administration for the Interagency Coordinating Council reimbursable services agreement.	100.0	0.0	0.0
3032	Inter-Agency Health	Rev - Department-wide	Reimbursable Services Agreement Department of Revenue, Alaska Mental Health Trust Authority, Long Term Ombudsman Office. Costs incurred to administer the Long Term Ombudsman Care office.	475.6	0.0	0.0

Inter-Agency Services (1682)
Department of Health & Social Services

Component: Senior and Disabilities Services Administration (2663)

Object Class		Servicing Agency	Explanation	FY2022 Actuals	FY2023 Management Plan	FY2024 Governor
3032	Inter-Agency Health	Univ - Department-wide	Reimbursable Services Agreement with the University of Alaska	232.3	0.0	0.0
3037	State Equipment Fleet	Trans - Department-wide	Department of Transportation and Public Facilities, State Equipment Fleet services.	31.0	0.0	0.0
3038	Inter-Agency Management/Consulting	H&SS - Information Technology Services (2754)	Reimbursable Services Agreement Department Wide, Infant Learning Program Application, Unique Object Framework Eradication	764.5	0.0	0.0
3017	Inter-Agency Information Technology Non-Telecommunications	Admin - Department-wide	Reimbursable Services Agreement Department of Administration, Office of Information Technology Core Services Chargeback includes Computer Resources Enterprise Productivity Rate, Virtual Private Network telecommunications, Computer Resources, select Adobe licensing, select Microsoft licensing, other software costs.	0.0	80.0	80.0
3017	Inter-Agency Information Technology Non-Telecommunications	H&SS - Information Technology Services (2754)	Reimbursable Services Agreement Department Wide: Information Technology Network Services Chargeback	0.0	150.0	150.0
3017	Inter-Agency Information Technology Non-Telecommunications	H&SS - Information Technology Services (2754)	Reimbursable Services Agreement Department Wide: Information Technology Customer Services Chargeback	0.0	261.0	261.0
3017	Inter-Agency Information Technology Non-Telecommunications	H&SS - Information Technology Services (2754)	Reimbursable Services Agreement Department Wide: Business Apps Chargeback	0.0	183.0	183.0
3017	Inter-Agency Information Technology Non-Telecommunications	H&SS - Information Technology Services (2754)	Reimbursable Services Agreement Infant Learning Program Business Apps Chargeback	0.0	7.0	7.0
3018	Inter-Agency Information Technology Telecommunications	Admin - Department-wide	Reimbursable Services Agreement Department of Administration, Office of Information Technology Microsoft	0.0	20.0	20.0

Inter-Agency Services (1682)
Department of Health & Social Services

Component: Senior and Disabilities Services Administration (2663)

Object Class		Servicing Agency	Explanation	FY2022 Actuals	FY2023 Management Plan	FY2024 Governor
3020	Inter-Agency Building Maintenance	Trans - Department-wide	Exchange. Reimbursable Services Agreement Department of Transportation and Public Facilities for building maintenance.	0.0	50.0	50.0
3021	Inter-Agency Mail	Admin - Department-wide	Reimbursable Services Agreement Department of Administration, postage, and mail service costs.	0.0	1.8	1.8
3022	Inter-Agency Human Resources	Admin - Department-wide	Reimbursable Services Agreement Department of Administration, Administrative Services Division, Human Resource Services. The cost to provide standardized, consistent, and quality services in all areas of human resource services.	0.0	123.0	123.0
3023	Inter-Agency Building Leases	Admin - Department-wide	Reimbursable Services Agreement Department of Administration, Division of General Services, Building Lease Costs: Anchorage Lease #2078 Fairbanks Lease #2531 Juneau Lease #4012 Anchorage Atwood Bldg.	0.0	545.1	600.0
3024	Inter-Agency Legal	Law - Department-wide	Reimbursable Services Agreement Department of Law, Civil Division, Regulation Review, Legal Services Costs for review and transmittal of administrative regulations	0.0	1.6	1.6
3025	Inter-Agency Auditing	H&SS - Administrative Support Svcs (320)	Reimbursable Services Agreement Department Wide: Audit Support from Finance & Management Services	0.0	30.0	30.0
3026	Inter-Agency Insurance	Admin - Department-wide	Reimbursable Services Agreement Department of Administration, Risk Management.	0.0	24.0	24.0

Inter-Agency Services (1682)
Department of Health & Social Services

Component: Senior and Disabilities Services Administration (2663)

Object Class	Servicing Agency	Explanation	FY2022 Actuals	FY2023 Management Plan	FY2024 Governor	
3028	Inter-Agency Americans with Disabilities Act Compliance	Admin - Department-wide	Reimbursable Services Agreement Department of Administration, Americans with Disabilities Act chargeback. Cost incurred to comply with the Americans with Disabilities Act to ensure services, programs, and activities are readily accessible to and usable by individuals with disabilities.	0.0	1.7	1.7
3030	Inter-Agency Hearing/Mediation	Admin - Department-wide	Reimbursable Services Agreement Department of Administration, Centralized Administrative Services, Hearing Officer Services for Senior and Disabilities Services.	0.0	10.0	10.0
3032	Inter-Agency Health	H&SS - Commission on Aging (2674)	Reimbursable Services Agreement Department of Health & Social Services, Alaska Commission on Aging, Services to Senior and Disabilities Services. Cost to provide coordinated services to seniors.	0.0	214.0	214.0
3032	Inter-Agency Health	H&SS - Governor's Cncl/Disabilities (2023)	Reimbursable Services Agreement Division of Senior and Disabilities Administration for the Interagency Coordinating Council reimbursable services agreement.	0.0	100.0	100.0
3032	Inter-Agency Health	Rev - Department-wide	Reimbursable Services Agreement Department of Revenue, Alaska Mental Health Trust Authority, Long Term Ombudsman Office. Costs incurred to administer the Long Term Ombudsman Care office.	0.0	498.1	498.1
3036	Inter-Agency Safety	Admin - Department-wide	Reimbursable Services Agreement Department of Administration, General Services Division, Parking Security Services.	0.0	0.7	0.7
3037	State Equipment Fleet	Trans - Department-wide	Department of Transportation and Public Facilities, State Equipment	0.0	30.0	30.0

Inter-Agency Services (1682)
Department of Health & Social Services

Component: Senior and Disabilities Services Administration (2663)

Object Class		Servicing Agency	Explanation	FY2022 Actuals	FY2023 Management Plan	FY2024 Governor
3038	Inter-Agency Management/Consulting	H&SS - Information Technology Services (2754)	Fleet services. Reimbursable Services Agreement Department Wide, Infant Learning Program Application, Unique Object Framework Eradication	0.0	35.0	35.0
3038	Inter-Agency Management/Consulting	Univ - Department-wide	Reimbursable Services Agreement University of Alaska Anchorage, Child Welfare Academy, Infant Learning Program, Professional Development In-Service Activities	0.0	150.0	150.0
3038	Inter-Agency Management/Consulting	H&SS - Administrative Support Svcs (320)	Reimbursable Services Agreement Department Wide: Finance and Management Services support	0.0	73.0	73.0
3038	Inter-Agency Management/Consulting	H&SS - Bureau of Vital Statistics (961)	Reimbursable Services Agreement Vital Statistics Data Reporting	0.0	3.0	3.0
3038	Inter-Agency Management/Consulting	H&SS - Commissioner's Office (317)	Reimbursable Services Agreement Department Wide: Commissioner's Office Services	0.0	14.0	14.0
3038	Inter-Agency Management/Consulting	H&SS - Information Technology Services (2754)	Reimbursable Services Agreement Department of Health and Social Services, Finance and Management Services, Inter-Agency Management and Consulting Services.	0.0	24.7	24.7
3038	Inter-Agency Management/Consulting	Univ - Department-wide	Reimbursable Services Agreement University of Alaska Anchorage, Center for Human Development, Infant Learning Program, Early Intervention Research and Evaluation	0.0	120.0	120.0
3038	Inter-Agency Management/Consulting	H&SS - Public Affairs (2874)	Reimbursable Services Agreement Department Wide: Public Affairs Support	0.0	205.0	205.0

Personal Services Expenditure Detail
Department of Health

Scenario: FY2024 Governor (19867)
Component: Senior and Disabilities Services Administration (2663)
RDU: Senior and Disabilities Services (487)

PCN	Job Class Title	Time Status	Retire Code	Barg Unit	Location	Salary Sched	Range / Step	Comp Months	Split / Count	Annual Salaries	COLA	Premium Pay	Annual Benefits	Total Costs	UGF Amount
02-1502	Health Program Manager 3	FT	A	SS	Juneau	205	21F	12.0		100,797	1,386	0	59,522	161,705	80,853
02-1515	Health Program Manager 2	FT	A	GP	Juneau	205	19D / E	12.0		79,775	2,743	0	48,954	131,472	32,868
02-1522	Office Assistant 1	FT	A	GP	Anchorage	200	8J	12.0		40,599	1,396	0	34,244	76,239	38,120
02-1533	Senior Services Technician	FT	A	GP	Anchorage	200	12E / F	12.0		46,964	1,615	0	36,634	85,213	85,213
02-1535	Health Program Manager 2	FT	A	GP	Anchorage	200	19G	12.0		81,159	2,791	0	49,474	133,424	66,712
02-1538	Health Program Manager 3	FT	A	SS	Anchorage	200	21K	12.0		102,336	1,408	0	60,100	163,844	81,922
02-1539	Health Program Manager 1	FT	A	GP	Anchorage	200	17E / F	12.0		67,127	2,308	0	44,205	113,640	56,820
02-1540	Administrative Assistant 2	FT	A	GP	Anchorage	200	14A	12.0		46,898	1,613	0	36,609	85,120	42,560
02-1541	Health Program Manager 1	FT	A	GP	Anchorage	200	17L	12.0		78,819	2,710	0	48,595	130,124	65,062
02-1543	Medicaid Program Specialist 1	FT	A	GP	Anchorage	200	16F / G	12.0		64,436	2,216	0	43,194	109,846	54,923
02-1545	Protective Services Manager 1	FT	A	SS	Anchorage	200	21M / N	12.0		110,275	1,517	0	63,081	174,873	87,437
02-1546	Health Program Manager 2	FT	A	GP	Anchorage	200	19F / G	12.0		78,880	2,712	0	48,618	130,210	65,105
02-1548	Medicaid Program Specialist 1	FT	A	GP	Anchorage	200	16C / D	12.0		59,027	2,030	0	41,163	102,220	51,110
02-1550	Pro Svcs Sp 2	FT	A	GP	Anchorage	200	17G / J	12.0		73,822	2,539	0	46,719	123,080	61,540
02-1551	Senior Services Technician	FT	A	GP	Anchorage	200	12C / D	12.0		44,424	1,528	0	35,680	81,632	81,632
02-1553	Office Assistant 2	FT	A	GP	Anchorage	200	10G	12.0		43,953	1,511	0	35,503	80,967	40,484
02-1808	Senior Services Technician	FT	A	GP	Anchorage	200	12A / B	12.0		42,530	1,463	0	34,969	78,962	39,481
02-1809	Health Program Manager 1	FT	A	GP	Anchorage	200	17C / D	12.0		64,106	2,204	0	43,070	109,380	54,690
02-1810	Medicaid Program Specialist 1	FT	A	GP	Anchorage	200	16N	12.0		78,644	2,704	0	48,529	129,877	64,939
02-1815	Health Program Manager 3	FT	A	SS	Anchorage	200	21L / M	12.0		105,807	1,455	0	61,403	168,665	84,333
02-1816	Pro Svcs Sp 4	FT	A	SS	Fairbanks	203	20N	12.0		105,747	1,455	0	61,381	168,583	84,292
02-1818	Administrative Assistant 2	FT	A	GP	Anchorage	200	14G / J	12.0		59,185	2,035	0	41,223	102,443	51,222
02-1819	Health Program Manager 2	FT	A	GP	Anchorage	200	19G / J	12.0		83,914	2,886	0	50,508	137,308	68,654
02-1821	Health Program Manager 2	FT	A	GP	Anchorage	200	19K	12.0		87,282	3,001	0	51,773	142,056	47,352
02-1822	Senior Services Technician	FT	A	GP	Anchorage	200	12B / C	12.0		43,004	1,479	0	35,147	79,630	79,630
02-7001	Division Director - Px	FT	A	XE	Anchorage	N00	27J / J	12.0		126,984	0	0	69,211	196,195	98,098
02-7013	Office Assistant 2	FT	A	GP	Anchorage	200	10E / F	12.0		41,685	1,433	0	34,651	77,769	77,769
02-7324	Administrative Officer 1	FT	A	SS	Anchorage	200	17J / K	12.0		77,075	1,060	0	50,614	128,749	64,375
02-7409	Office Assistant 2	FT	A	GP	Anchorage	200	10E / F	12.0		41,685	1,433	0	34,651	77,769	77,769
02-7444	Program Coordinator 1	FT	A	SS	Anchorage	200	18J / K	12.0		83,467	1,148	0	53,014	137,629	0
02-7481	Administrative Officer 2	FT	A	SS	Juneau	205	19E / F	12.0		88,201	1,213	0	54,792	144,206	72,103
02-7498	Pro Svcs Sp 3	FT	A	GP	Juneau	205	19L	12.0		94,614	3,254	0	54,526	152,394	76,197
02-7575	Health Program Manager 2	FT	A	GP	Juneau	205	19D / E	12.0		79,470	2,733	0	48,840	131,043	65,522
02-7599	Health Program Manager 2	FT	A	SS	Anchorage	200	19F	12.0		84,157	1,158	0	53,274	138,589	69,295
06-0341	Pro Svcs Sp 3	FT	A	GP	Anchorage	200	19B / C	12.0		69,888	2,403	0	45,242	117,533	58,767

Note: If a position is split, an asterisk (*) will appear in the Split/Count column. If the split position is also counted in the component, two asterisks (**) will appear in this column. [No valid job title] appearing in the Job Class Title indicates that the PCN has an invalid class code or invalid range for the class code effective date of this scenario.

Personal Services Expenditure Detail
Department of Health

Scenario: FY2024 Governor (19867)
Component: Senior and Disabilities Services Administration (2663)
RDU: Senior and Disabilities Services (487)

PCN	Job Class Title	Time Status	Retire Code	Barg Unit	Location	Salary Sched	Range / Step	Comp Months	Split / Count	Annual Salaries	COLA	Premium Pay	Annual Benefits	Total Costs	UGF Amount
06-0515	Health Program Manager 2	FT	A	GP	Anchorage	200	19D / E	12.0		75,102	2,583	0	47,199	124,884	62,442
06-0520	Office Assistant 2	FT	A	GP	Anchorage	200	10K / L	12.0		47,955	1,649	0	37,006	86,610	43,305
06-1211	Admn OPS Mgr 2	FT	A	SS	Juneau	205	23K	12.0		123,178	1,694	0	67,926	192,798	96,399
06-1469	Office Assistant 2	FT	A	GP	Anchorage	200	10G	12.0		43,953	1,511	0	35,503	80,967	40,484
06-1492	Medicaid Program Specialist 3	FT	A	GP	Anchorage	200	20J / K	12.0		91,035	3,130	0	53,182	147,347	73,674
06-1494	Health Program Manager 4	FT	A	SS	Anchorage	200	23K	12.0		117,312	1,614	0	65,723	184,649	123,098
06-1616	Pro Svcs Sp 3	FT	A	GP	Anchorage	200	19F / G	12.0		79,560	2,736	0	48,873	131,169	65,585
06-1639	Research Analyst 3	FT	A	GP	Anchorage	200	18D / E	12.0		70,548	2,426	0	45,489	118,463	59,232
06-1640	Health Program Manager 2	FT	A	GP	Anchorage	200	19D / E	12.0		74,908	2,576	0	47,127	124,611	0
06-1649	Health Program Manager 2	FT	A	GP	Anchorage	200	19B / C	12.0		69,888	2,403	0	45,242	117,533	0
06-1828	Accountant 3	FT	A	GP	Juneau	205	18G / J	12.0		82,658	2,842	0	50,037	135,537	67,769
06-1938	Health Program Manager 2	FT	A	GP	Anchorage	200	19D / E	12.0		73,942	2,543	0	46,764	123,249	0
06-1968	Health Program Manager 4	FT	A	SS	Fairbanks	203	23Q / R	12.0		147,283	2,026	0	76,977	226,286	84,857
06-1974	Senior Services Technician	FT	A	GP	Anchorage	200	12J	12.0		52,260	1,797	0	38,622	92,679	46,340
06-2020	Health Program Manager 4	FT	A	SS	Anchorage	200	23M / N	12.0		128,430	1,767	0	69,898	200,095	100,048
06-2027	Health Program Manager 1	FT	P	GP	Fairbanks	203	17M	12.0		83,811	2,882	0	50,470	137,163	68,582
06-2194	Health Program Manager 1	FT	A	GP	Anchorage	200	17J	12.0		73,944	2,543	0	46,765	123,252	61,626
06-2233	Health Program Manager 2	FT	A	GP	Juneau	205	19D / E	12.0		79,165	2,722	0	48,725	130,612	65,306
06-2240	Health Program Manager 2	FT	A	GP	Juneau	205	19F / G	12.0		84,586	2,909	0	50,761	138,256	46,085
06-2241	Health Program Manager 2	FT	A	SS	Fairbanks	203	19K / L	12.0		93,499	1,286	0	56,781	151,566	75,783
06-2250	Nurse 3	FT	A	SS	Anchorage	200	24Q / R	12.0		152,272	2,095	0	78,851	233,218	116,609
06-2253	Health Program Manager 3	FT	A	SS	Anchorage	200	21K	12.0		102,336	1,408	0	60,100	163,844	81,922
06-2256	Medicaid Program Specialist 1	FT	A	GP	Anchorage	200	16C / D	12.0		58,990	2,029	0	41,149	102,168	51,084
06-2259	Health Program Manager 1	FT	A	GP	Anchorage	200	17C / D	12.0		62,526	2,150	0	42,477	107,153	53,577
06-2260	Health Program Manager 1	FT	A	GP	Anchorage	200	17J / K	12.0		76,243	2,622	0	47,628	126,493	63,247
06-2261	Health Program Manager 1	FT	A	GP	Anchorage	200	17K / L	12.0		77,168	2,654	0	47,975	127,797	63,899
06-2263	Senior Services Technician	FT	A	GP	Anchorage	200	12E / F	12.0		47,271	1,626	0	36,749	85,646	42,823
06-2265	Health Program Manager 2	FT	A	GP	Juneau	205	19G / J	12.0		86,516	2,975	0	51,485	140,976	70,488
06-2266	Administrative Assistant 2	FT	A	GP	Juneau	205	14D / E	12.0		55,998	1,926	0	40,026	97,950	48,975
06-2267	Health Program Manager 2	FT	A	SS	Anchorage	200	19C / D	12.0		77,382	1,064	0	50,730	129,176	64,588
06-2272	Health Program Manager 3	FT	A	SS	Juneau	205	21J	12.0		104,062	1,431	0	60,748	166,241	83,121
06-2273	Health Program Manager 2	FT	A	GP	Anchorage	100	19B / C	12.0		70,512	2,425	0	45,476	118,413	59,207
06-2326	Project Assistant	FT	A	GP	Anchorage	200	16N / O	12.0		79,389	2,730	0	48,809	130,928	0
06-2339	Health Program Manager 2	FT	A	SS	Anchorage	200	19J / K	12.0		89,239	1,227	0	55,182	145,648	72,824
06-2340	Training Specialist 1	FT	A	GP	Anchorage	200	16K	12.0		71,448	2,457	0	45,827	119,732	59,866
06-2341	Health Program Manager 2	FT	A	SS	Anchorage	200	19D / E	12.0		80,855	1,112	0	52,034	134,001	67,001
06-2342	Health Program Manager 2	FT	A	GP	Juneau	205	19C / D	12.0		76,760	2,640	0	47,822	127,222	63,611

Note: If a position is split, an asterisk (*) will appear in the Split/Count column. If the split position is also counted in the component, two asterisks (**) will appear in this column. [No valid job title] appearing in the Job Class Title indicates that the PCN has an invalid class code or invalid range for the class code effective date of this scenario.

Personal Services Expenditure Detail
Department of Health

Scenario: FY2024 Governor (19867)
Component: Senior and Disabilities Services Administration (2663)
RDU: Senior and Disabilities Services (487)

PCN	Job Class Title	Time Status	Retire Code	Barg Unit	Location	Salary Sched	Range / Step	Comp Months	Split / Count	Annual Salaries	COLA	Premium Pay	Annual Benefits	Total Costs	UGF Amount
06-2343	Health Program Manager 1	FT	A	GP	Anchorage	200	17L / M	12.0		80,841	2,780	0	49,354	132,975	66,488
06-2344	Health Program Manager 1	FT	A	GP	Anchorage	200	17F / G	12.0		68,946	2,371	0	44,888	116,205	58,103
06-2345	Health Program Manager 1	FT	A	GP	Anchorage	200	17E / F	12.0		68,661	2,361	0	44,781	115,803	57,902
06-2346	Health Program Manager 1	FT	A	GP	Anchorage	200	17C / D	12.0		62,490	2,149	0	42,464	107,103	53,552
06-2347	Pro Svcs Sp 2	FT	A	GP	Anchorage	200	17B / C	12.0		61,847	2,127	0	42,222	106,196	53,098
06-2350	Medicaid Program Specialist 3	FT	A	GP	Anchorage	200	20O	12.0		106,119	3,649	0	58,846	168,614	84,307
06-2351	Medicaid Program Specialist 1	FT	A	GP	Anchorage	200	16B / C	12.0		56,765	1,952	0	40,314	99,031	49,516
06-2358	Health Program Manager 2	FT	A	GP	Anchorage	200	19D / E	12.0		75,779	2,606	0	47,454	125,839	62,920
06-2359	Health Program Manager 1	FT	A	GP	Anchorage	200	17D / E	12.0		64,895	2,232	0	43,367	110,494	55,247
06-2361	Pro Svcs Sp 4	FT	A	SS	Anchorage	99	20M / N	12.0		101,650	1,398	0	59,842	162,890	81,445
06-2362	Health Program Associate	FT	A	SS	Anchorage	200	16E / F	12.0		67,406	927	0	46,984	115,317	115,317
06-2363	Training Specialist 2	FT	A	GP	Anchorage	200	18A / B	12.0		63,775	2,193	0	42,946	108,914	54,457
06-2364	Health Program Manager 2	FT	A	GP	Anchorage	200	19B / C	12.0		69,341	2,384	0	45,036	116,761	58,381
06-2365	Senior Services Technician	FT	A	GP	Anchorage	200	12E / F	12.0		48,163	1,656	0	37,084	86,903	86,903
06-2368	Pro Svcs Sp 3	FT	A	GP	Anchorage	200	19J	12.0		84,533	2,907	0	50,741	138,181	69,091
06-2369	Health Program Manager 1	FT	A	GP	Anchorage	200	17B / C	12.0		60,764	2,090	0	41,816	104,670	52,335
06-2371	Health Program Manager 1	FT	A	GP	Anchorage	200	17K / L	12.0		76,446	2,629	0	47,704	126,779	63,390
06-2372	Health Program Manager 1	FT	A	GP	Anchorage	200	17C / D	12.0		63,206	2,173	0	42,733	108,112	54,056
06-2373	Office Assistant 2	FT	A	GP	Anchorage	200	10B / C	12.0		38,781	1,334	0	33,561	73,676	36,838
06-2374	Office Assistant 2	FT	A	GP	Anchorage	200	10B / C	12.0		38,855	1,336	0	33,589	73,780	36,890
06-2375	Senior Services Technician	FT	A	GP	Anchorage	200	12G	12.0		50,135	1,724	0	37,824	89,683	44,842
06-2376	Senior Services Technician	FT	A	GP	Anchorage	200	12F / G	12.0		49,179	1,691	0	37,465	88,335	44,168
06-2377	Health Program Associate	FT	A	SS	Anchorage	200	16E / F	12.0		68,474	942	0	47,385	116,801	116,801
06-2378	Pro Svcs Sp 3	FT	A	GP	Fairbanks	203	19D / E	12.0		77,394	2,661	0	48,060	128,115	64,058
06-2379	Pro Svcs Sp 3	FT	A	GP	Anchorage	200	19K / L	12.0		89,638	3,082	0	52,658	145,378	72,689
06-2380	Health Program Manager 3	FT	A	SS	Anchorage	200	21F / J	12.0		97,812	1,345	0	58,401	157,558	52,519
06-2381	Medicaid Program Specialist 1	FT	A	GP	Anchorage	200	16C / D	12.0		58,371	2,007	0	40,917	101,295	50,648
06-2386	Senior Services Technician	FT	A	GP	Anchorage	200	12B / C	12.0		43,241	1,487	0	35,236	79,964	39,982
06-2387	Training Specialist 2	FT	A	GP	Anchorage	200	18C / D	12.0		67,357	2,316	0	44,291	113,964	56,982
06-2388	Nurse 2	FT	A	GP	Anchorage	200	22F / G	12.0		101,440	0	0	57,089	158,529	79,265
06-2390	Research Analyst 4	FT	A	GP	Fairbanks	203	21B / C	12.0		83,287	2,864	0	50,273	136,424	0
06-2392	Division Operations Manager	FT	A	SS	Juneau	205	24P / Q	12.0		155,275	2,136	0	79,978	237,389	118,695
06-2393	Health Program Manager 2	FT	A	GP	Anchorage	200	19J	12.0		84,533	2,907	0	50,741	138,181	69,091
06-2394	Health Program Manager 2	FT	A	GP	Anchorage	200	19C / D	12.0		73,652	2,533	0	46,655	122,840	61,420
06-2395	Health Program Manager 2	FT	A	GP	Anchorage	200	19L	12.0		90,110	3,099	0	52,835	146,044	73,022

Note: If a position is split, an asterisk (*) will appear in the Split/Count column. If the split position is also counted in the component, two asterisks (**) will appear in this column. [No valid job title] appearing in the Job Class Title indicates that the PCN has an invalid class code or invalid range for the class code effective date of this scenario.

Personal Services Expenditure Detail
Department of Health

Scenario: FY2024 Governor (19867)
Component: Senior and Disabilities Services Administration (2663)
RDU: Senior and Disabilities Services (487)

PCN	Job Class Title	Time Status	Retire Code	Barg Unit	Location	Salary Sched	Range / Step	Comp Months	Split / Count	Annual Salaries	COLA	Premium Pay	Annual Benefits	Total Costs	UGF Amount
06-2396	Health Program Associate	FT	A	SS	Anchorage	200	16C / D	12.0		63,224	870	0	45,413	109,507	54,754
06-2397	Health Program Manager 2	FT	A	GP	Anchorage	200	19D / E	12.0		73,903	2,541	0	46,749	123,193	61,597
06-2398	Health Program Manager 2	FT	A	GP	Juneau	205	19D / E	12.0		79,673	2,740	0	48,916	131,329	65,665
06-2399	Health Program Manager 3	FT	A	SS	Anchorage	200	21D / E	12.0		91,146	1,254	0	55,898	148,298	74,149
06-2400	Nurse 2	FT	A	GP	Anchorage	200	22E / F	12.0		94,352	3,245	0	54,428	152,025	76,013
06-2401	Health Program Manager 2	FT	A	GP	Anchorage	200	19G / J	12.0		81,749	2,811	0	49,695	134,255	67,128
06-2402	Health Program Manager 2	FT	A	GP	Anchorage	200	19G / J	12.0		83,127	2,859	0	50,213	136,199	68,100
06-2403	Health Program Manager 2	FT	A	GP	Anchorage	200	19D / E	12.0		75,141	2,584	0	47,214	124,939	62,470
06-2404	Nurse 2	FT	A	GP	Anchorage	200	22B / C	12.0		84,256	2,897	0	50,637	137,790	68,895
06-2406	Pro Svcs Sp 2	FT	A	GP	Anchorage	200	17L / M	12.0		80,841	2,780	0	49,354	132,975	66,488
06-2407	Medicaid Program Specialist 4	FT	A	SS	Anchorage	200	21L / M	12.0		107,380	1,477	0	61,994	170,851	42,713
06-2409	Pro Svcs Sp 3	FT	A	GP	Anchorage	200	19B / C	12.0		70,378	2,420	0	45,426	118,224	59,112
06-2410	Pro Svcs Sp 3	FT	A	GP	Anchorage	200	19K	12.0		87,282	3,001	0	51,773	142,056	71,028
06-2411	Health Program Manager 2	FT	A	GP	Anchorage	200	19F / G	12.0		80,559	2,770	0	49,249	132,578	66,289
06-2412	Health Program Manager 2	FT	A	GP	Fairbanks	203	19C / D	12.0		73,913	2,542	0	46,753	123,208	61,604
06-2413	Health Program Manager 2	FT	A	SS	Anchorage	200	19M / N	12.0		96,930	1,333	0	58,070	156,333	78,167
06-2414	Health Program Manager 2	FT	A	SS	Anchorage	200	19J	12.0		86,882	1,195	0	54,297	142,374	71,187
06-2416	Medicaid Program Specialist 3	FT	N	GP	Anchorage	200	20E / F	12.0		84,123	2,365	0	29,472	115,960	57,980
06-2417	Nurse 2	FT	A	GP	Anchorage	200	22J	12.0		109,376	0	0	60,069	169,445	84,723
06-2418	Health Program Manager 2	FT	A	GP	Anchorage	200	19F / G	12.0		79,260	2,726	0	48,761	130,747	65,374
06-2419	Health Program Manager 2	FT	A	GP	Anchorage	200	19A / B	12.0		68,431	2,353	0	44,694	115,478	57,739
06-2420	Health Program Manager 2	FT	A	GP	Anchorage	200	19M	12.0		93,035	3,199	0	53,933	150,167	50,055
06-2431	Senior Services Technician	FT	A	GP	Anchorage	200	12A / B	12.0		42,255	1,453	0	34,865	78,573	26,191
06-2432	Office Assistant 2	FT	A	GP	Anchorage	200	10D / E	12.0		40,414	1,390	0	34,174	75,978	37,989
06-2433	Health Program Manager 2	FT	A	GP	Anchorage	200	19C / D	12.0		71,546	2,460	0	45,864	119,870	59,935
06-2434	Pro Svcs Sp 2	FT	A	GP	Anchorage	200	17E / F	12.0		68,661	2,361	0	44,781	115,803	57,902
06-2435	Health Program Manager 1	FT	A	GP	Anchorage	200	17C / D	12.0		62,600	2,153	0	42,505	107,258	53,629
06-2436	Nurse 2	FT	A	GP	Anchorage	200	22B / C	12.0		86,245	2,966	0	51,384	140,595	70,298
06-2437	Training Specialist 3	FT	A	SS	Anchorage	200	20N	12.0		105,498	1,451	0	61,287	168,236	84,118
06-2438	Health Program Manager 2	FT	A	GP	Anchorage	200	19B / C	12.0		69,002	2,373	0	44,909	116,284	58,142
06-2439	Health Program Manager 2	FT	A	GP	Anchorage	200	19B / C	12.0		70,529	2,425	0	45,482	118,436	59,218
06-2440	Health Program Manager 2	FT	A	GP	Anchorage	200	19J	12.0		84,533	2,907	0	50,741	138,181	69,091
06-2441	Health Program Manager 2	FT	A	GP	Anchorage	200	19B / C	12.0		70,529	2,425	0	45,482	118,436	59,218
06-2442	Health Program Manager 2	FT	A	GP	Anchorage	200	19G / J	12.0		82,565	2,839	0	50,002	135,406	45,135
06-2443	Medicaid Program Specialist 1	FT	A	GP	Anchorage	200	16C / D	12.0		58,390	2,008	0	40,924	101,322	50,661
06-2445	Health Program Manager 2	FT	A	GP	Anchorage	200	19G	12.0		81,159	2,791	0	49,474	133,424	66,712

Note: If a position is split, an asterisk (*) will appear in the Split/Count column. If the split position is also counted in the component, two asterisks (**) will appear in this column. [No valid job title] appearing in the Job Class Title indicates that the PCN has an invalid class code or invalid range for the class code effective date of this scenario.

Personal Services Expenditure Detail
Department of Health

Scenario: FY2024 Governor (19867)
Component: Senior and Disabilities Services Administration (2663)
RDU: Senior and Disabilities Services (487)

PCN	Job Class Title	Time Status	Retire Code	Barg Unit	Location	Salary Sched	Range / Step	Comp Months	Split / Count	Annual Salaries	COLA	Premium Pay	Annual Benefits	Total Costs	UGF Amount
06-2446	Health Program Manager 2	FT	A	GP	Anchorage	200	19C / D	12.0		72,445	2,491	0	46,202	121,138	60,569
06-2447	Health Program Manager 2	FT	A	GP	Anchorage	200	19F / G	12.0		79,860	2,746	0	48,986	131,592	65,796
06-2553	Health Program Manager 3	FT	A	SS	Anchorage	200	21E / F	12.0		93,858	1,291	0	56,916	152,065	152,065
06-2554	Medicaid Program Specialist 3	FT	A	GP	Anchorage	200	20O	12.0		106,119	3,649	0	58,846	168,614	84,307
06-2555	Medicaid Program Specialist 3	FT	A	GP	Anchorage	200	20E / F	12.0		82,246	2,828	0	49,882	134,956	67,478
06-2566	Pro Svcs Sp 2	FT	A	GP	Anchorage	200	17N	12.0		84,026	2,889	0	50,550	137,465	68,733
06-2575	Office Assistant 2	FT	A	GP	Anchorage	200	10C / D	12.0		39,253	1,350	0	33,738	74,341	0
06-3426	Pro Svcs Sp 3	FT	A	GP	Anchorage	200	19B / C	12.0		69,888	2,403	0	45,242	117,533	58,767
06-3714	Pro Svcs Sp 3	FT	A	GP	Anchorage	200	19B / C	12.0		69,831	2,401	0	45,220	117,452	58,726
06-3725	Pro Svcs Sp 4	FT	A	SS	Anchorage	200	20B / C	12.0		79,934	1,099	0	51,688	132,721	66,361
06-3904	Health Program Manager 2	FT	A	GP	Anchorage	200	19M	12.0		93,035	3,199	0	53,933	150,167	75,084
06-4006	Research Analyst 3	FT	A	GP	Anchorage	200	18C / D	12.0		67,165	2,310	0	44,219	113,694	56,847
06-4014	Health Program Manager 2	FT	A	SS	Anchorage	200	19E / F	12.0		81,786	1,125	0	52,383	135,294	67,647
06-4061	Medicaid Program Specialist 3	FT	A	GP	Anchorage	200	20C / D	12.0		78,180	2,688	0	48,355	129,223	64,612
06-4082	Pro Svcs Sp 2	FT	A	GP	Anchorage	200	17E / F	12.0		67,894	2,335	0	44,493	114,722	57,361
06-4090	Research Analyst 4	FT	A	SS	Anchorage	200	21L	12.0		105,664	1,453	0	61,349	168,466	84,233
06-4105	Health Program Manager 2	FT	A	SS	Anchorage	200	19F / J	12.0		85,292	1,173	0	53,700	140,165	70,083
06-8466	Pro Svcs Sp 3	FT	A	GP	Fairbanks	203	19E / F	12.0		79,090	2,720	0	48,697	130,507	65,254
06-8539	Nurse 2	FT	A	GP	Anchorage	200	22F	12.0		105,924	0	0	58,773	164,697	82,349
06-8623	Health Program Manager 2	FT	A	GP	Anchorage	200	19G / J	12.0		84,392	2,902	0	50,688	137,982	45,994
06-N18045	Research Analyst 1	NP	N	GP	Anchorage	200	13B / C	12.0		46,898	1,318	0	24,837	73,053	36,527
06-N19018	Health Program Manager 2	NP	N	GP	Fairbanks	203	19B / C	12.0		73,145	2,056	0	28,105	103,306	0
06-N21001	Program Coordinator 1	NP	N	GP	Juneau	205	18B / C	12.0		69,771	1,961	0	27,685	99,417	49,709
06-N21002	Project Assistant	NP	N	GP	Anchorage	200	16B / C	12.0		57,662	1,621	0	26,178	85,461	0
06-N21033	Pro Svcs Sp 3	NP	N	GP	Anchorage	200	19B / C	12.0		71,019	1,997	0	27,841	100,857	0

Note: If a position is split, an asterisk (*) will appear in the Split/Count column. If the split position is also counted in the component, two asterisks (**) will appear in this column. [No valid job title] appearing in the Job Class Title indicates that the PCN has an invalid class code or invalid range for the class code effective date of this scenario.

Personal Services Expenditure Detail
Department of Health

Scenario: FY2024 Governor (19867)
Component: Senior and Disabilities Services Administration (2663)
RDU: Senior and Disabilities Services (487)

PCN	Job Class Title	Time Status	Retire Code	Barg Unit	Location	Salary Sched	Range / Step	Comp Months	Split / Count	Annual Salaries	COLA	Premium Pay	Annual Benefits	Total Costs	UGF Amount
		Total Positions	New	Deleted										Total Salary Costs:	12,971,145
														Total COLA:	354,767
	Full Time Positions:	163	0	0										Total Premium Pay:	0
	Part Time Positions:	0	0	0										Total Benefits:	8,060,173
	Non Permanent Positions:	5	0	0											
	Positions in Component:	168	0	0											
	Total Component Months:	2,016.0													
														Total Pre-Vacancy:	21,386,085
														Minus Vacancy Adjustment of 4.41%:	(942,185)
														Total Post-Vacancy:	20,443,900
														Plus Lump Sum Premium Pay:	0
														Personal Services Line 100:	20,443,900

PCN Funding Sources:	Pre-Vacancy	Post-Vacancy	Percent
1002 Federal Receipts	10,536,643	10,072,441	49.27%
1003 General Fund Match	9,340,033	8,928,548	43.67%
1007 Interagency Receipts	416,644	398,288	1.95%
1037 General Fund / Mental Health	992,628	948,897	4.64%
1092 Mental Health Trust Authority Authorized Receipts	100,137	95,725	0.47%
Total PCN Funding:	21,386,085	20,443,900	100.00%

Note: If a position is split, an asterisk (*) will appear in the Split/Count column. If the split position is also counted in the component, two asterisks (**) will appear in this column. [No valid job title] appearing in the Job Class Title indicates that the PCN has an invalid class code or invalid range for the class code effective date of this scenario.

FY2024 Governor
 Department of Health
 Senior and Disabilities Services
 Senior and Disabilities Services Administration

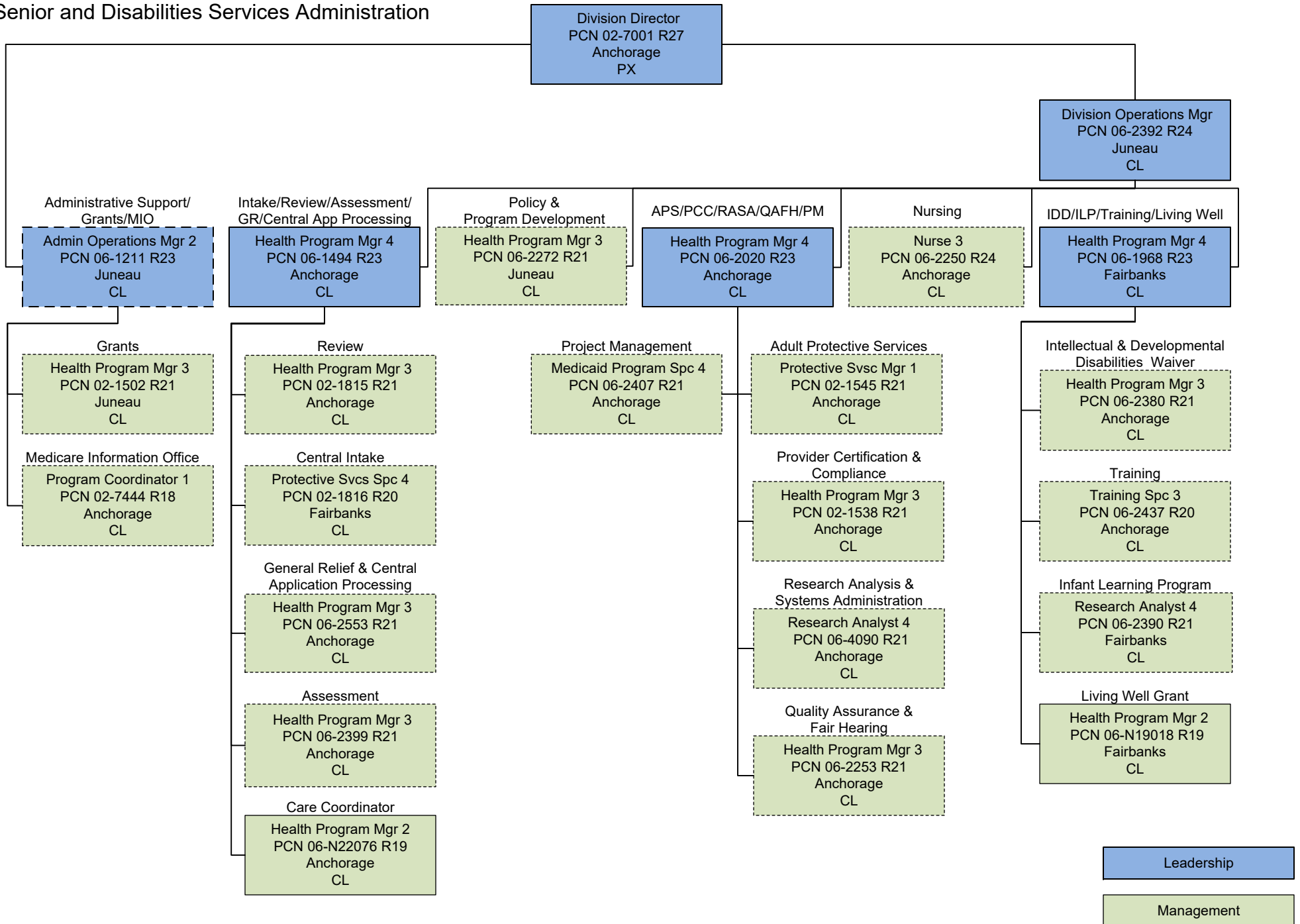

FY2024 Governor
 Department of Health
 Senior and Disabilities Services
 Senior and Disabilities Services Administration
 Quality Assurance and Fair Hearing

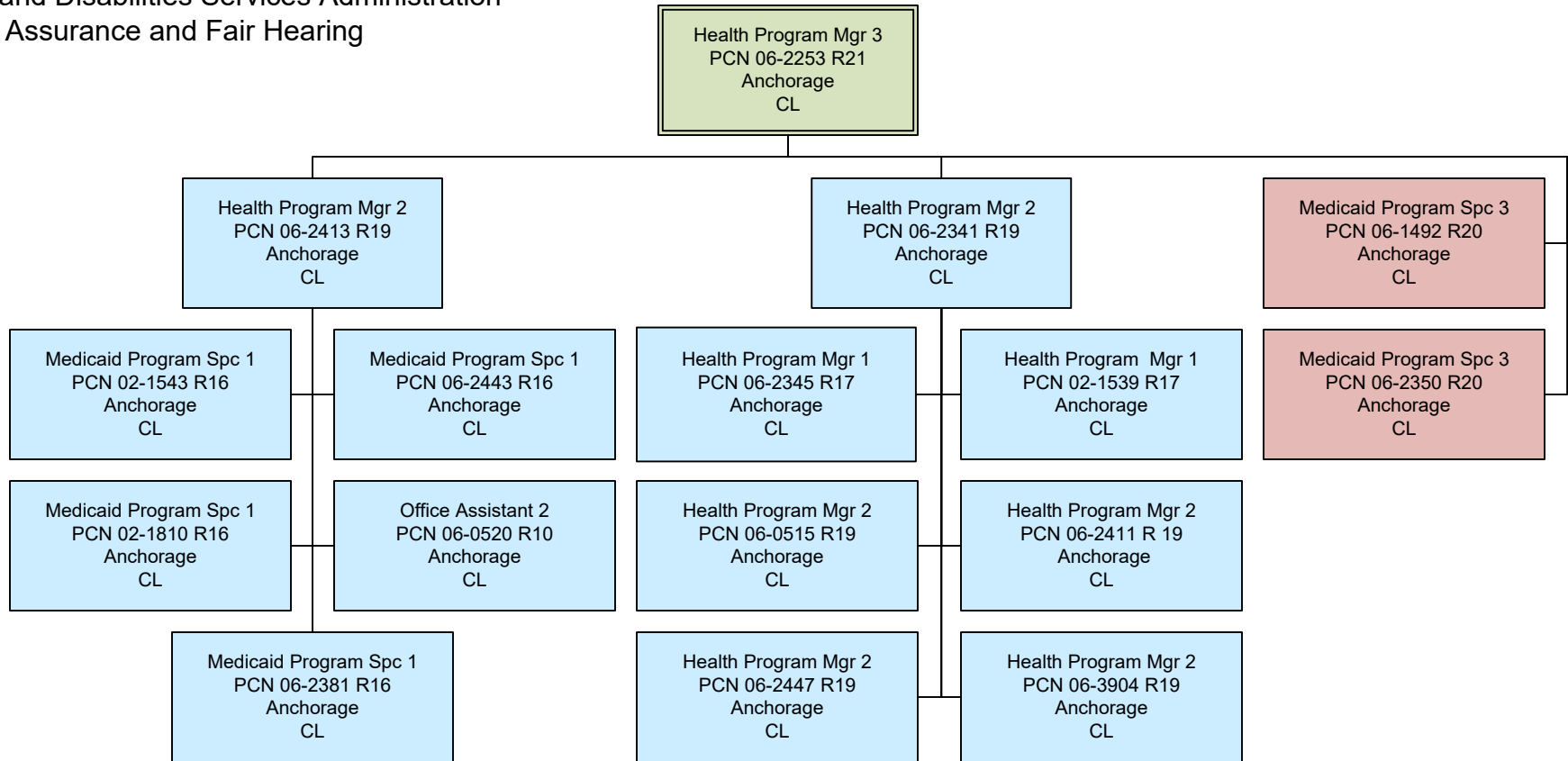

Fair Hearing

Quality Assurance

FY2024 Governor
Department of Health
Senior and Disabilities Services
Senior and Disabilities Services Administration
Provider Certification and Compliance

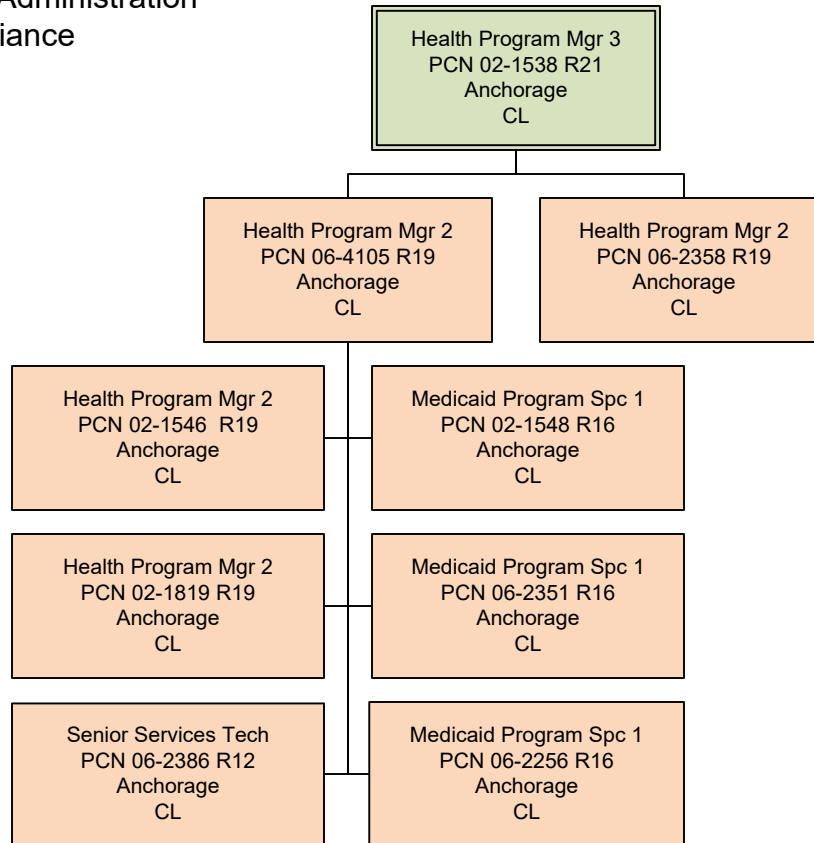

FY2024 Governor
Department of Health
Senior and Disabilities Services
Senior and Disabilities Services Administration
Research and Analysis
Systems Administration

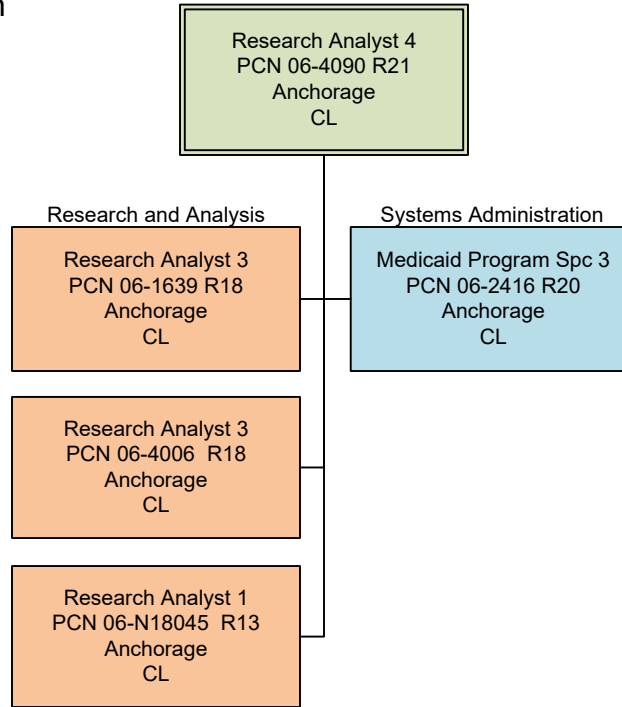

Research and Analysis

Systems Administration

FY2024 Governor
Department of Health
Senior and Disabilities Services
Senior and Disabilities Services Administration
Central Intake

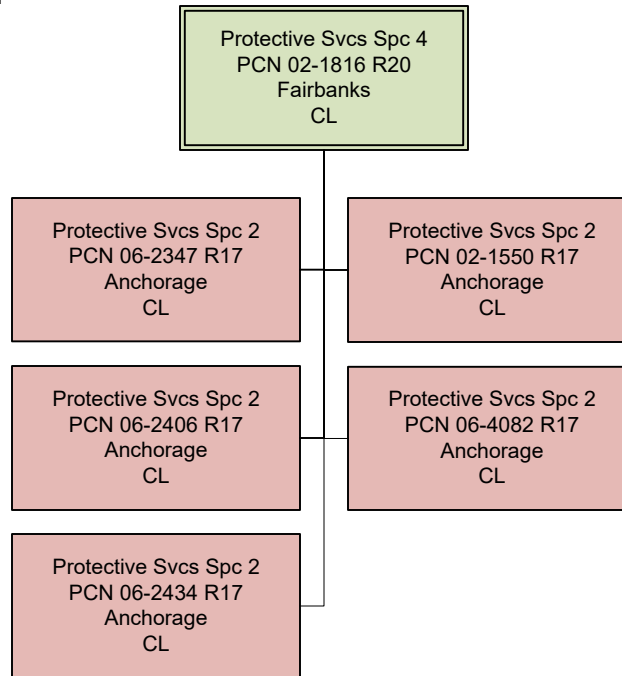

FY2024 Governor
Department of Health
Senior and Disabilities Services
Senior and Disabilities Services Administration
Adult Protective Services

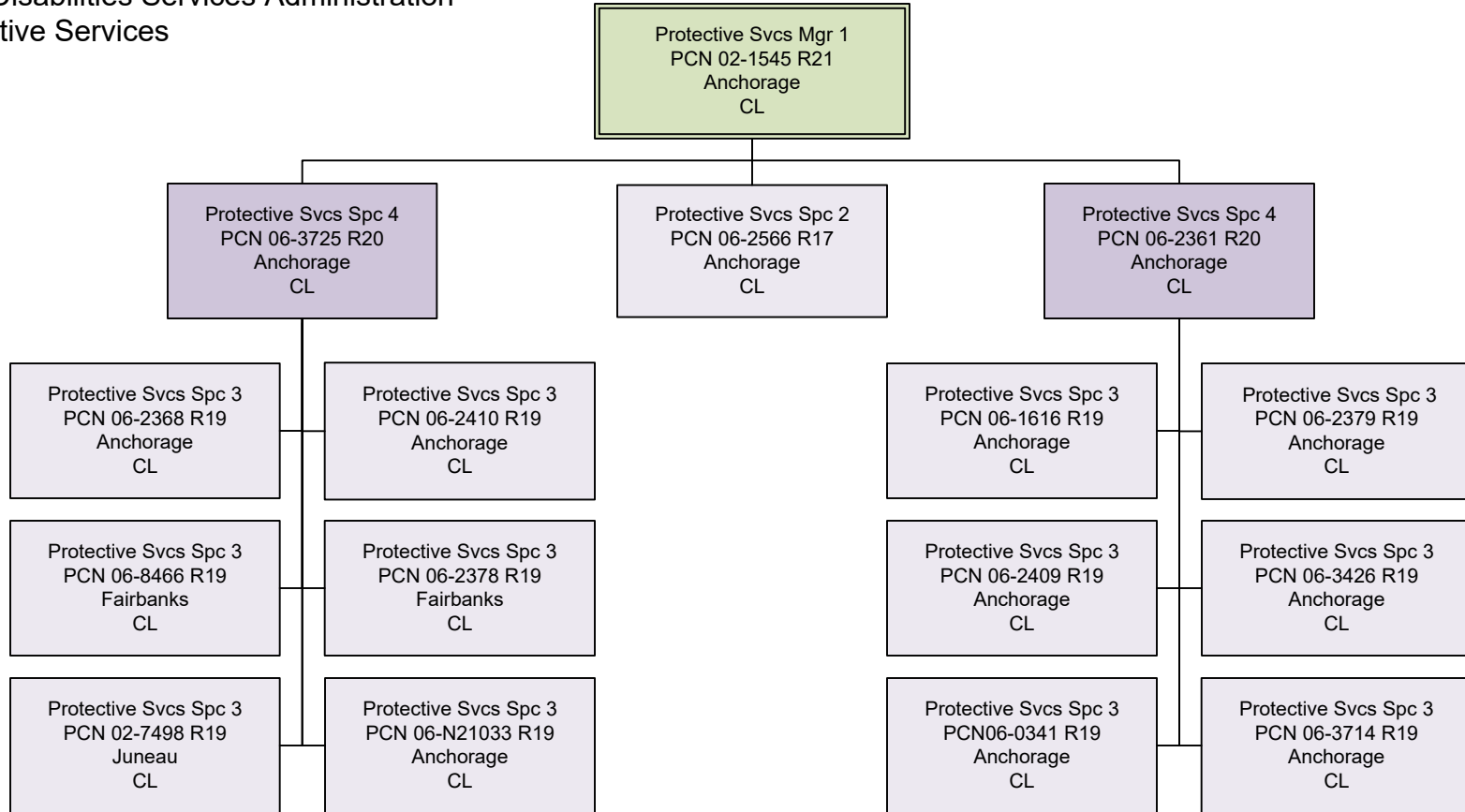

FY2024 Governor
Department of Health
Senior and Disabilities Services
Senior and Disabilities Services Administration
General Relief and Central Application Processing

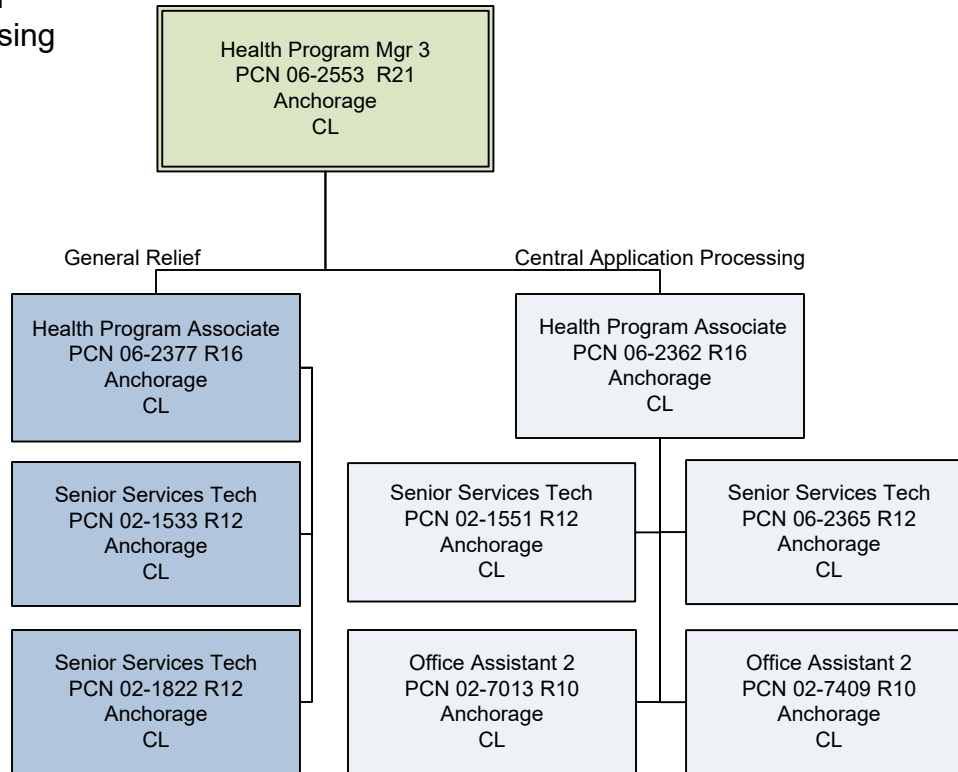

General Relief

Central Application Processing

FY2024 Governor
Department of Health
Senior and Disabilities Services
Senior and Disabilities Services Administration
Nursing

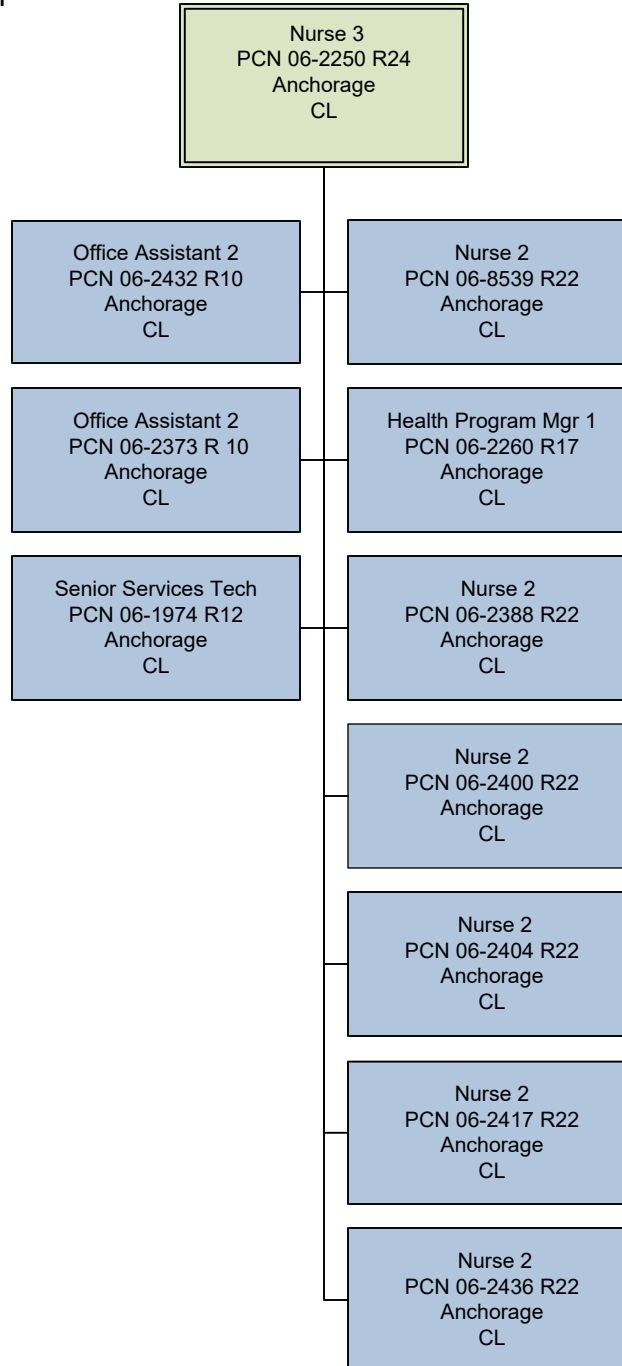

FY2024 Governor
Department of Health
Senior and Disabilities Services
Senior and Disabilities Services Administration
Project Management

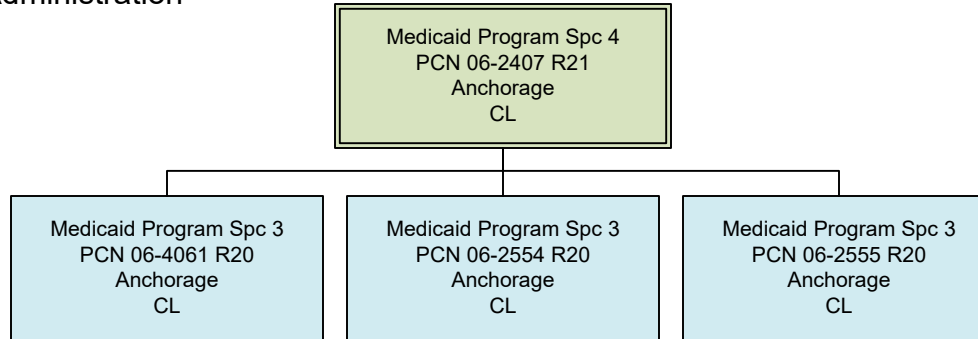

FY2024 Governor
 Department of Health
 Senior and Disabilities Services
 Senior and Disabilities Services Administration
 Administrative Support, Grants and
 Medicare Information Office

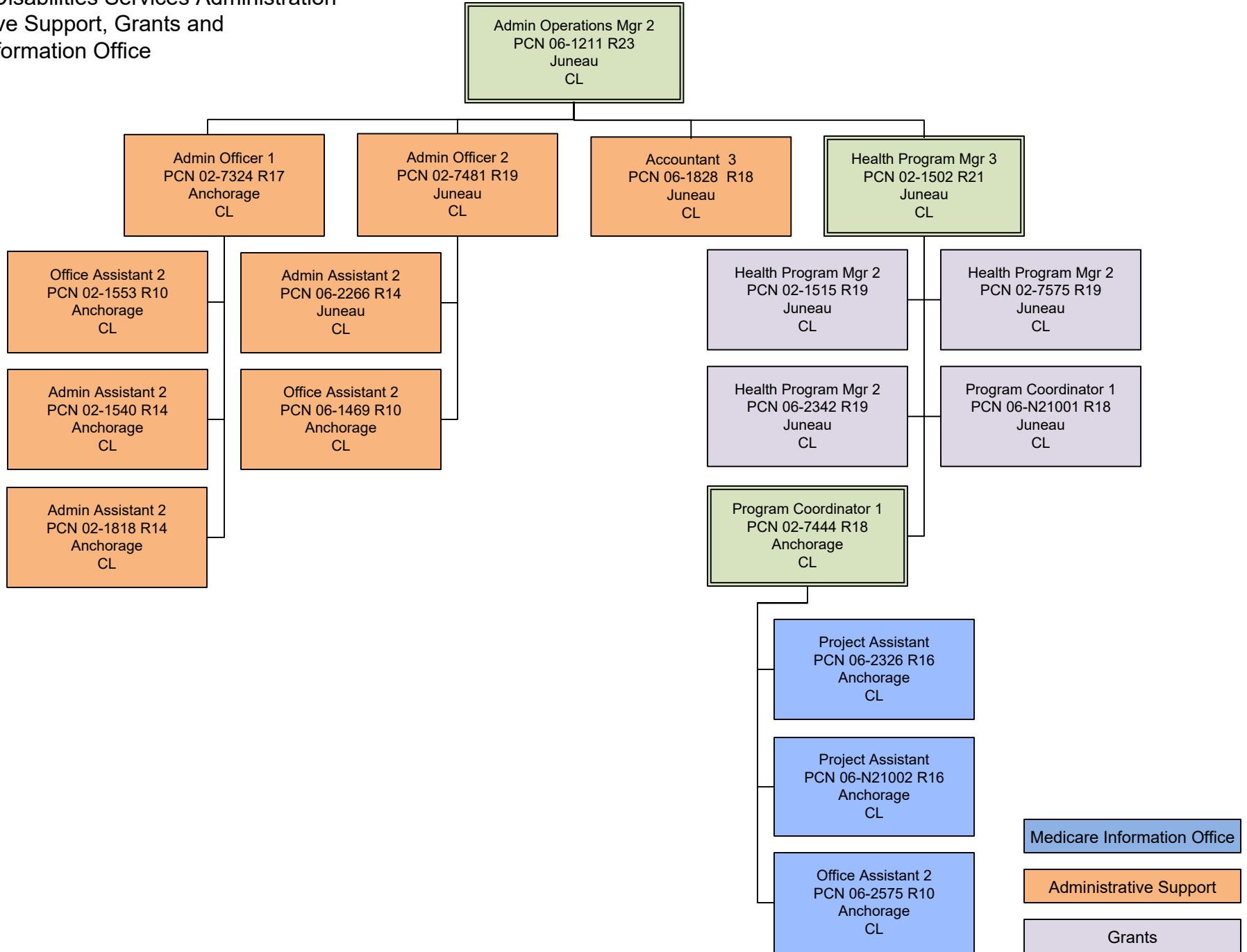

FY2024 Governor
Department of Health
Senior and Disabilities Services
Senior and Disabilities Services Administration
Policy and Program Development

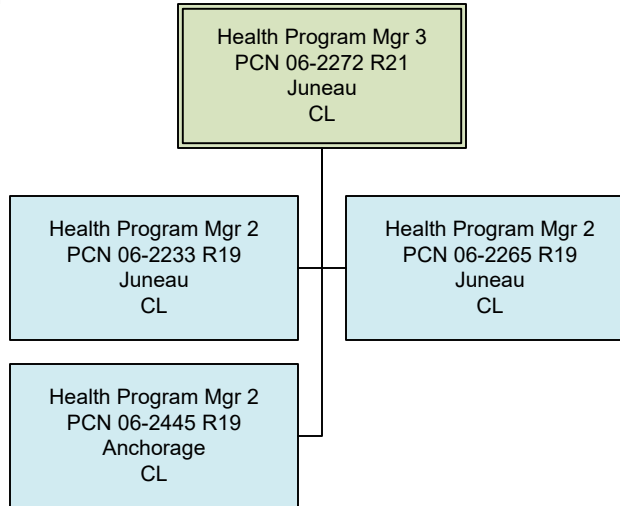

FY2024 Governor
Department of Health
Senior and Disabilities Services
Senior and Disabilities Services Administration
Training

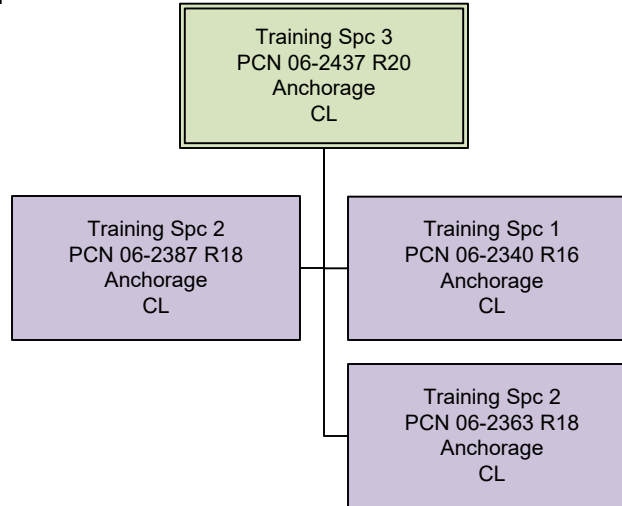

FY2024 Governor
 Department of Health
 Senior and Disabilities Services
 Senior and Disabilities Services Administration
 Assessment

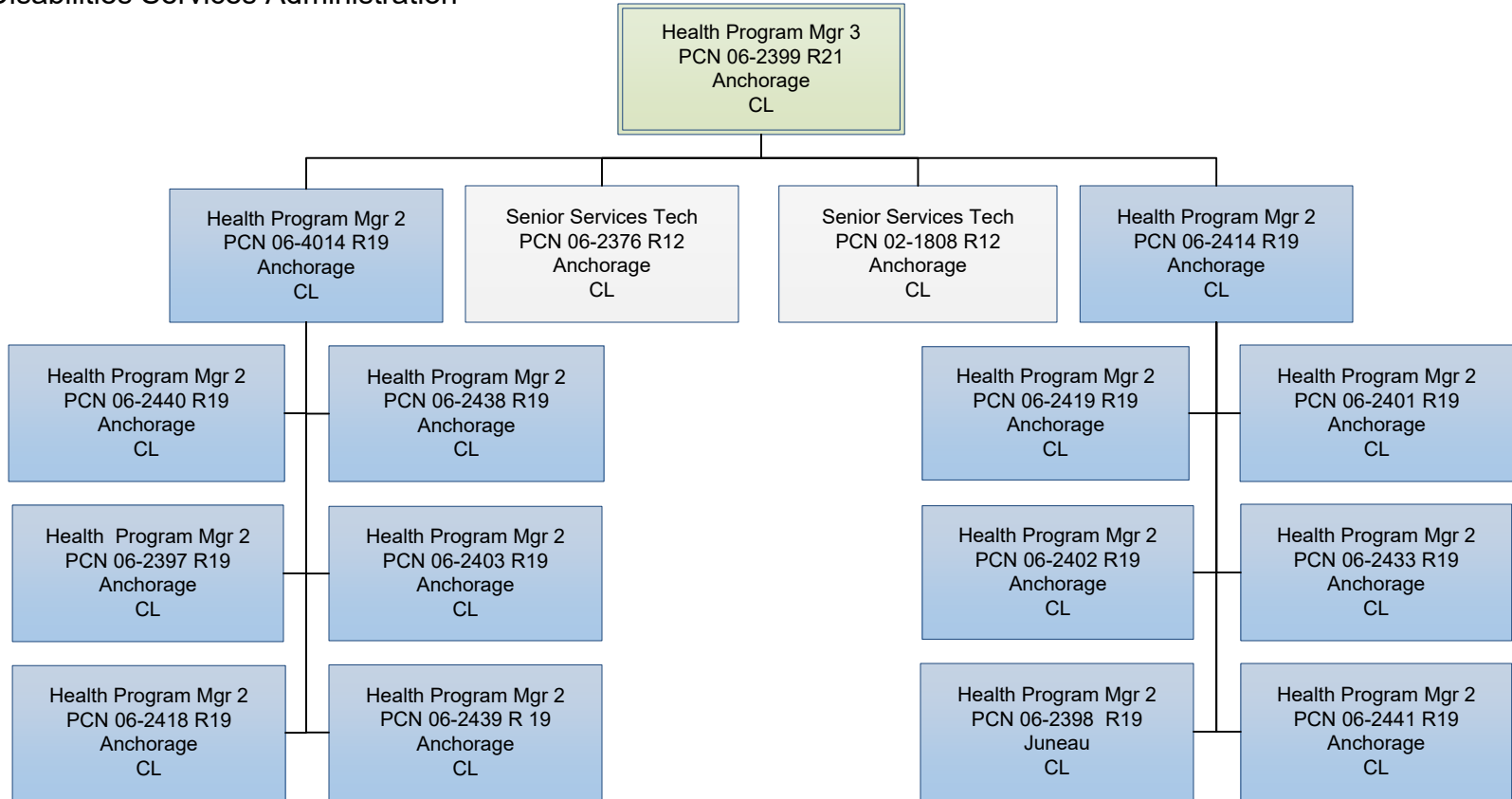

Assessors

Support

FY2024 Governor
 Department of Health
 Senior and Disabilities Services
 Senior and Disabilities Services Administration
 Review

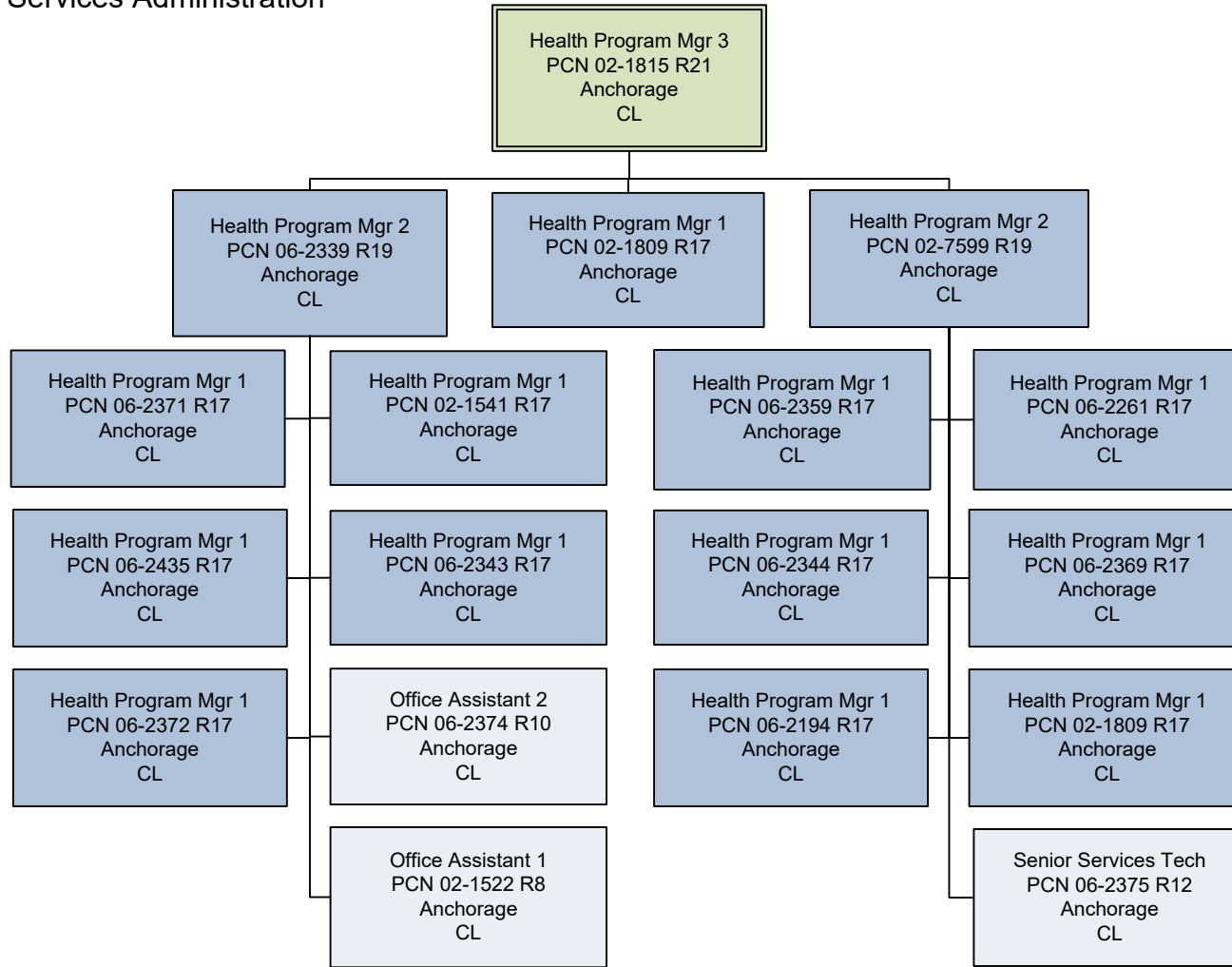

FY2024 Governor
 Department of Health
 Senior and Disabilities Services
 Senior and Disabilities Services Administration
 Intellectual & Developmental Disabilities Waiver

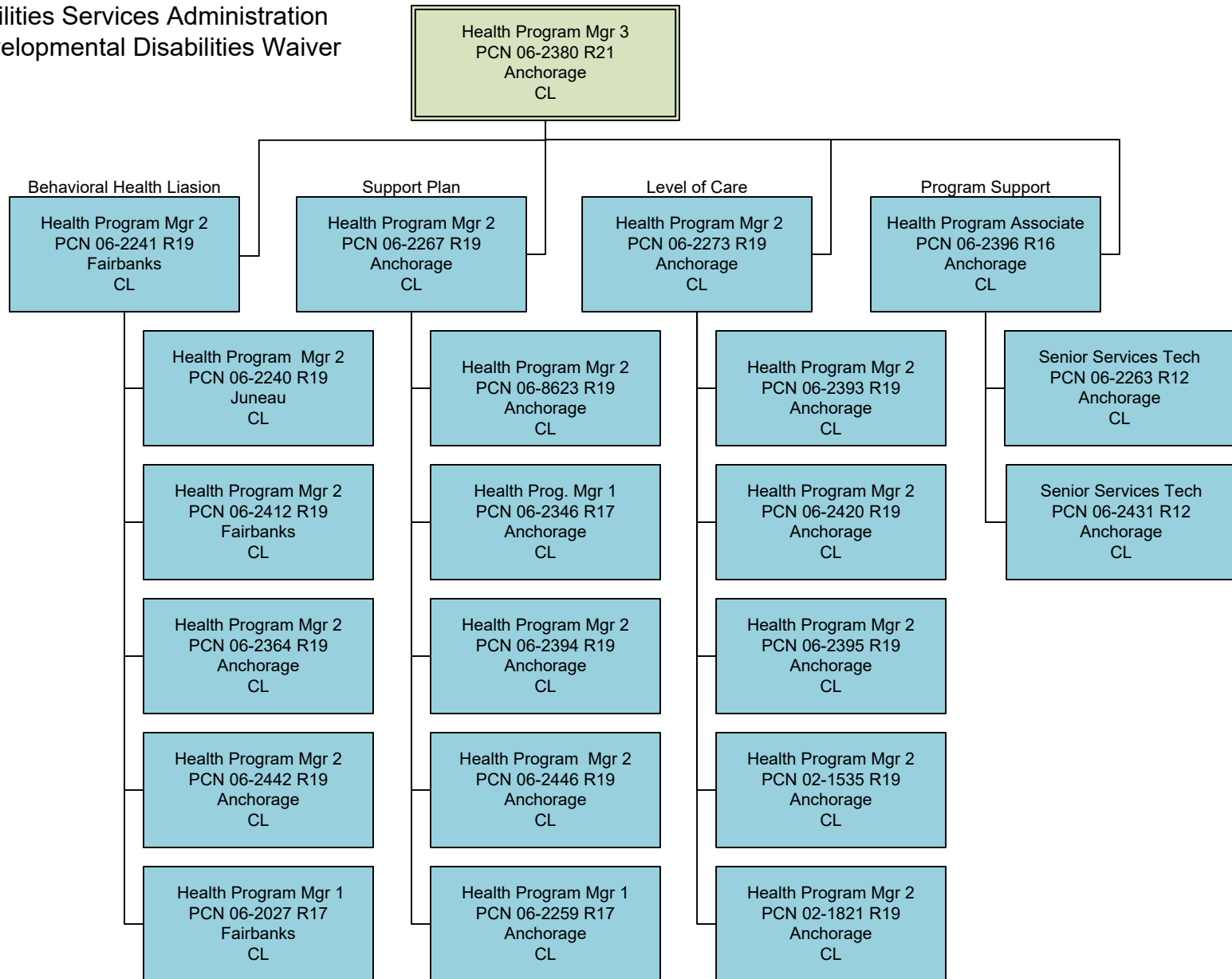

FY2024 Governor
Department of Health
Senior and Disabilities Services
Senior and Disabilities Services Administration
Early Intervention/Infant Learning Programs

