

State of Alaska FY2024 Governor's Operating Budget

Department of Law Office of the Attorney General Component Budget Summary

Component: Office of the Attorney General

Contribution to Department's Mission

The Attorney General is the state's chief law enforcement officer, overseeing the state's involvement in all civil matters and criminal prosecutions, and leading over 500 attorneys and staff in the Department of Law's twelve offices throughout the state. The Attorney General serves as trustee on the Exxon Valdez Oil Spill Trustee Council.

Core Services

- Protecting the safety and physical and financial well-being of Alaskans.
- Fostering the conditions for economic opportunity and for the responsible development and use of our natural resources.
- Protecting the fiscal integrity of the State of Alaska.
- Promoting and defending good governance.

Major Component Accomplishments in 2022

Major accomplishments are shown at the department level.

Key Component Challenges

Key component challenges are shown at the department level.

Significant Changes in Results to be Delivered in FY2024

Changes in results are shown at the department level.

Statutory and Regulatory Authority

AS 44.23.020

Contact Information

Contact: Treg Taylor, Attorney General

Phone: (907) 269-5100

E-mail: treg.taylor@alaska.gov

Office of the Attorney General Personal Services Information					
Authorized Positions			Personal Services Costs		
	<u>FY2023</u> <u>Management</u> <u>Plan</u>	<u>FY2024</u> <u>Governor</u>			
Full-time	4	4	Annual Salaries		443,124
Part-time	0	0	Premium Pay		0
Nonpermanent	0	0	Annual Benefits		252,234
			<i>Less 0.07% Vacancy Factor</i>		(458)
			Lump Sum Premium Pay		0
Totals	4	4	Total Personal Services		694,900

Position Classification Summary					
Job Class Title	Anchorage	Fairbanks	Juneau	Others	Total
Commissioner	1	0	0	0	1
Executive Secretary 3	1	0	0	0	1
Sp Asst Commr 2	2	0	0	0	2
Totals	4	0	0	0	4

Component Detail All Funds
Department of Law

Component: Office of the Attorney General (2162)
RDU: Administration and Support (280)

Non-Formula Component

	FY2022 Actuals	FY2023 Conference Committee	FY2023 Authorized	FY2023 Management Plan	FY2024 Governor	FY2023 Management Plan vs FY2024 Governor	
71000 Personal Services	663.7	659.3	688.3	688.3	694.9	6.6	1.0%
72000 Travel	23.0	39.3	39.3	18.5	58.5	40.0	216.2%
73000 Services	102.4	13.8	13.8	19.6	129.6	110.0	561.2%
74000 Commodities	2.9	13.0	13.0	28.0	28.0	0.0	0.0%
75000 Capital Outlay	0.0	0.0	0.0	0.0	0.0	0.0	0.0%
77000 Grants, Benefits	0.0	0.0	0.0	0.0	0.0	0.0	0.0%
78000 Miscellaneous	0.0	0.0	0.0	0.0	0.0	0.0	0.0%
Totals	792.0	725.4	754.4	754.4	911.0	156.6	20.8%
Fund Sources:							
1004 Gen Fund (UGF)	476.2	534.6	563.6	563.6	568.1	4.5	0.8%
1007 I/A Rcpts (Other)	315.8	190.8	190.8	190.8	342.9	152.1	79.7%
Unrestricted General (UGF)	476.2	534.6	563.6	563.6	568.1	4.5	0.8%
Designated General (DGF)	0.0	0.0	0.0	0.0	0.0	0.0	0.0%
Other Funds	315.8	190.8	190.8	190.8	342.9	152.1	79.7%
Federal Funds	0.0	0.0	0.0	0.0	0.0	0.0	0.0%
Positions:							
Permanent Full Time	4	4	4	4	4	0	0.0%
Permanent Part Time	0	0	0	0	0	0	0.0%
Non Permanent	0	0	0	0	0	0	0.0%

Change Record Detail - Multiple Scenarios with Descriptions
Department of Law

Component: Office of the Attorney General (2162)
RDU: Administration and Support (280)

Scenario/Change Record Title	Trans Type	Totals	Personal Services	Travel	Services	Commodities	Capital Outlay	Grants, Benefits	Miscellaneous	Positions		NP
										PFT	PPT	
***** Changes From FY2023 Conference Committee To FY2023 Authorized *****												
FY2023 Conference Committee												
	ConfCom	725.4	659.3	39.3	13.8	13.0	0.0	0.0	0.0	4	0	0
1004 Gen Fund		534.6										
1007 I/A Rcpts		190.8										
FY2023 Exempt 5% COLA												
	SalAdj	29.0	29.0	0.0	0.0	0.0	0.0	0.0	0.0	0	0	0
1004 Gen Fund		29.0										
FY2023 Exempt 5% COLA: \$29.0												
Subtotal		754.4	688.3	39.3	13.8	13.0	0.0	0.0	0.0	4	0	0
***** Changes From FY2023 Authorized To FY2023 Management Plan *****												
Transfer Authority from Travel for Anticipated Services and Commodities Expenditures												
	LIT	0.0	0.0	-20.8	5.8	15.0	0.0	0.0	0.0	0	0	0
Transfer authority from the travel line to the services and commodities lines for anticipated costs. The remaining travel authority is anticipated to be sufficient to cover operating expenditures.												
Subtotal		754.4	688.3	18.5	19.6	28.0	0.0	0.0	0.0	4	0	0
***** Changes From FY2023 Management Plan To FY2024 Governor *****												
Transfer from Administrative Services for Required Legal Expertise												
	Trin	150.0	0.0	40.0	110.0	0.0	0.0	0.0	0.0	0	0	0
1007 I/A Rcpts		150.0										
An alignment of fund sources between Attorney General's Office and the Administrative Services components is required in order to accommodate anticipated expenditures in the Attorney General's Office based on prior year expenditures.												
FY2024 AlaskaCare Health Insurance Increase - Exempt and Partially Exempt												
	SalAdj	5.2	5.2	0.0	0.0	0.0	0.0	0.0	0.0	0	0	0
1004 Gen Fund		3.5										
1007 I/A Rcpts		1.7										
FY2024 AlaskaCare health insurance increase for exempt and partially exempt employees from \$1,685 to \$1,793 per member per month.: \$5.2												
FY2024 PERS Rate Adjustment												
	SalAdj	1.4	1.4	0.0	0.0	0.0	0.0	0.0	0.0	0	0	0
1004 Gen Fund		1.0										

Change Record Detail - Multiple Scenarios with Descriptions
Department of Law

Component: Office of the Attorney General (2162)
RDU: Administration and Support (280)

Scenario/Change Record Title	Trans Type	Totals	Personal Services	Travel	Services	Commodities	Capital Outlay	Grants, Benefits	Miscellaneous	Positions		
										PFT	PPT	NP
1007 I/A Rcpts		0.4										
FY2024 PERS rate adjustment to 25.10%: \$1.4												
	Totals	911.0	694.9	58.5	129.6	28.0	0.0	0.0	0.0	4	0	0

Line Item Detail (1676)
Department of Law
Travel

Component: Office of the Attorney General (2162)

Line Number	Line Name		FY2022 Actuals	FY2023 Management Plan	FY2024 Governor
2000	Travel		23.0	18.5	58.5
Object Class	Servicing Agency	Explanation	FY2022 Actuals	FY2023 Management Plan	FY2024 Governor
2000 Travel Detail Totals			23.0	18.5	58.5
2000	In-State Employee Travel	Travel for attorneys to interview witnesses and attend court proceedings, as well as for necessary training for both attorneys and paraprofessionals. Includes travel for management purposes.	19.2	14.5	43.5
2002	Out of State Employee Travel	Travel costs and expenses for out-of-state travel for conferences, training, etc.	3.8	4.0	15.0

Line Item Detail (1676)
Department of Law
Services

Component: Office of the Attorney General (2162)

Line Number	Line Name		FY2022 Actuals	FY2023 Management Plan	FY2024 Governor
3000	Services		102.4	19.6	129.6
Object Class	Servicing Agency	Explanation	FY2022 Actuals	FY2023 Management Plan	FY2024 Governor
3000 Services Detail Totals			102.4	19.6	129.6
3000	Education Services	Conferences, training and memberships.	32.9	0.0	50.0
3002	Legal and Judicial Services	Depositions, research costs, expert witness and consultant fees.	26.4	2.5	40.0
3003	Information Technology	Training, consulting and software licensing and maintenance. Annual maintenance fee for mission-critical information management systems.	0.1	0.5	0.5
3004	Telecommunications	Local telephone service, long distance charges and cellular phone services paid to third-party telephone utilities.	5.0	6.0	7.0
3007	Advertising and Promotions	Publication of legal notices.	0.1	0.3	0.5
3009	Structure/Infrastructure/Land	Rentals/leases - records and evidence storage.	0.1	0.3	0.5
3011	Other Services	Cost transfers and miscellaneous items within the services line (commissions, etc.).	0.3	0.5	0.5
3013	Inter-Agency Data Processing Operations Allocation	Law - Administrative Services (2164) RSA Law, Information services, data processing investments and support.	0.0	0.1	0.1
3017	Inter-Agency Information Technology Non-Telecommunications	Admin - Department-wide RSA Administration, Office of Information Technology computer services.	0.0	1.9	1.9
3018	Inter-Agency Information Technology Telecommunications	Admin - Department-wide RSA Administration, Office of Information Technology telecommunications services.	0.0	1.1	1.1

Line Item Detail (1676)
Department of Law
Services

Component: Office of the Attorney General (2162)

Object Class	Servicing Agency	Explanation	FY2022 Actuals	FY2023 Management Plan	FY2024 Governor	
3000 Services Detail Totals			102.4	19.6	129.6	
3022	Inter-Agency Human Resources	Law - Administrative Services (2164)	RSA Law, Human Resources position.	0.0	2.7	2.7
3023	Inter-Agency Building Leases	Admin - Department-wide	Leased office space managed by General Services.	0.0	0.2	0.0
3023	Inter-Agency Building Leases	Trans - Department-wide	Leased office space managed by General Services.	37.2	2.7	24.0
3026	Inter-Agency Insurance	Admin - Department-wide	RSA Administration, Risk Management.	0.0	0.1	0.1
3027	Inter-Agency Financial		RSA Administration, Finance Chargeback (IRIS).	0.3	0.0	0.0
3027	Inter-Agency Financial	Admin - Department-wide	RSA Administration, Finance Chargeback (IRIS).	0.0	0.7	0.7

Line Item Detail (1676)
Department of Law
Commodities

Component: Office of the Attorney General (2162)

Line Number	Line Name		FY2022 Actuals	FY2023 Management Plan	FY2024 Governor
4000	Commodities		2.9	28.0	28.0
Object Class	Servicing Agency	Explanation	FY2022 Actuals	FY2023 Management Plan	FY2024 Governor
4000 Commodities Detail Totals			2.9	28.0	28.0
4000	Business	Reference materials and subscriptions, including statutes, software applications, non-capital desktop refresh, and miscellaneous office supplies.	2.9	28.0	27.5
4002	Household/Institutional	Institutional supplies for cleaning and maintenance.	0.0	0.0	0.5

Revenue Detail (1681)
Department of Law

Component: Office of the Attorney General (2162)

Revenue Type (OMB Fund Code) Revenue Source	Component	Comment	FY2022 Actuals	FY2023 Management Plan	FY2024 Governor
5007 I/A Rcpts (1007 I/A Rcpts)			315.8	190.8	342.9
5301 Inter-Agency Receipts	Law - Dep. Attny General's Office (2205)	RSA Law - Deputy Attorney General's Office - legal support services for the Civil Division. Program code: AG03501655.	315.8	190.7	342.9
5301 Inter-Agency Receipts	Law - Information and Project Support (2258)	RSA Law - Information and Project Support	0.0	0.1	0.0
6004 Gen Fund (1004 Gen Fund)			0.9	0.0	0.0
6047 General Fund - Miscellaneous		Miscellaneous	0.9	0.0	0.0

Inter-Agency Services (1682)
Department of Law

Component: Office of the Attorney General (2162)

				FY2022 Actuals	FY2023 Management Plan	FY2024 Governor
Component Totals				37.2	9.5	30.6
With Department of Law				0.0	2.8	2.8
With Department of Administration				0.0	4.0	3.8
With Department of Transportation/Public Facilities				37.2	2.7	24.0
Object Class	Servicing Agency	Explanation	FY2022 Actuals	FY2023 Management Plan	FY2024 Governor	
3013	Inter-Agency Data Processing Operations Allocation	Law - Administrative Services (2164)	RSA Law, Information services, data processing investments and support.	0.0	0.1	0.1
3017	Inter-Agency Information Technology Non-Telecommunications	Admin - Department-wide	RSA Administration, Office of Information Technology computer services.	0.0	1.9	1.9
3018	Inter-Agency Information Technology Telecommunications	Admin - Department-wide	RSA Administration, Office of Information Technology telecommunications services.	0.0	1.1	1.1
3022	Inter-Agency Human Resources	Law - Administrative Services (2164)	RSA Law, Human Resources position.	0.0	2.7	2.7
3023	Inter-Agency Building Leases	Admin - Department-wide	Leased office space managed by General Services.	0.0	0.2	0.0
3023	Inter-Agency Building Leases	Trans - Department-wide	Leased office space managed by General Services.	37.2	2.7	24.0
3026	Inter-Agency Insurance	Admin - Department-wide	RSA Administration, Risk Management.	0.0	0.1	0.1
3027	Inter-Agency Financial	Admin - Department-wide	RSA Administration, Finance Chargeback (IRIS).	0.0	0.7	0.7

Personal Services Expenditure Detail
Department of Law

Scenario: FY2024 Governor (19867)
Component: Office of the Attorney General (2162)
RDU: Administration and Support (280)

PCN	Job Class Title	Time Status	Retire Code	Barg Unit	Location	Salary Sched	Range / Step	Comp Months	Split / Count	Annual Salaries	COLA	Premium Pay	Annual Benefits	Total Costs	UGF Amount
03-0001	Commissioner	FT	A	XE	Anchorage	N00	0	12.0		169,709	0	0	84,790	254,499	254,499
03-0012	Executive Secretary 3	FT	A	XE	Anchorage	N00	16J / K	12.0		68,317	0	0	47,229	115,546	115,546
03-0310	Sp Asst Commr 2	FT	A	XE	Anchorage	N00	23K / L	12.0		114,884	0	0	64,748	179,632	129,335
03-0371	Sp Asst Commr 2	FT	A	XE	Anchorage	N00	23A / B	12.0		90,214	0	0	55,467	145,681	0
													Total Salary Costs:	443,124	
													Total COLA:	0	
													Total Premium Pay:	0	
													Total Benefits:	252,234	
													Total Pre-Vacancy:	695,358	
													Minus Vacancy Adjustment of 0.07%:	(458)	
													Total Post-Vacancy:	694,900	
													Plus Lump Sum Premium Pay:	0	
													Personal Services Line 100:	694,900	
Total Component Months:		48.0													

PCN Funding Sources:	Pre-Vacancy	Post-Vacancy	Percent
1004 General Fund Receipts	499,380	499,051	71.82%
1007 Interagency Receipts	195,978	195,849	28.18%
Total PCN Funding:	695,358	694,900	100.00%

Note: If a position is split, an asterisk (*) will appear in the Split/Count column. If the split position is also counted in the component, two asterisks (**) will appear in this column. [No valid job title] appearing in the Job Class Title indicates that the PCN has an invalid class code or invalid range for the class code effective date of this scenario.

**Administration and Support
FY2024 Governor Budget
Office of the Attorney General**

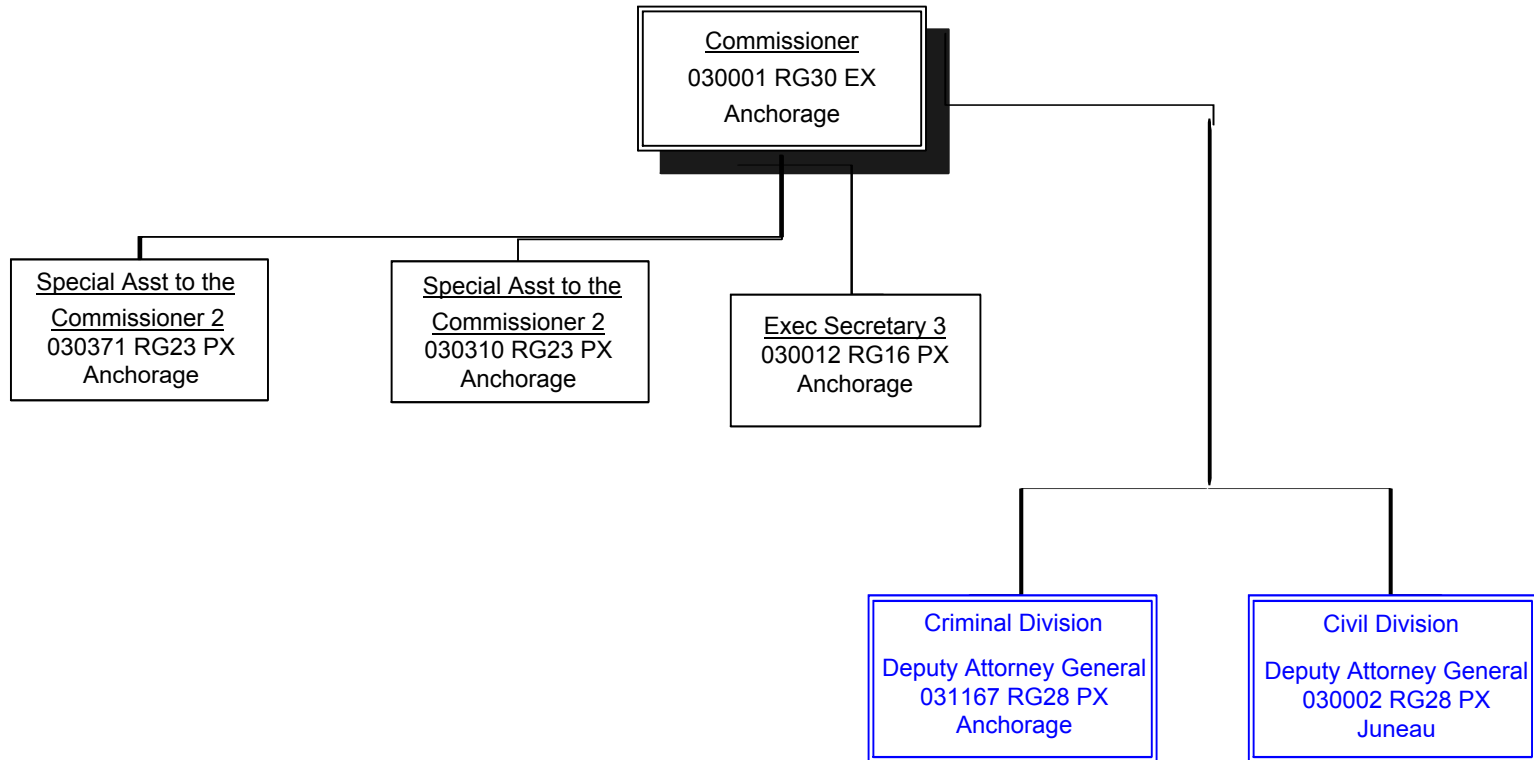

Note: Positions outlined in blue indicate that the PCNs are counted elsewhere but shown here to indicate organizational hierarchy.

Position Count: 4