

State of Alaska FY2026 Governor's Operating Budget

Department of Administration Office of Public Advocacy Component Budget Summary

Component: Office of Public Advocacy

Contribution to Department's Mission

Provide legal advocacy and guardian services to vulnerable Alaskans.

Results

(Additional performance information is available on the web at <https://omb.alaska.gov/results>.)

Core Services

- Guardianship Services.
- Guardian Ad Litem Services.
- Elder Fraud Litigation.

Measures by Core Service

(Additional performance information is available on the web at <https://omb.alaska.gov/results>.)

1. Guardianship Services.

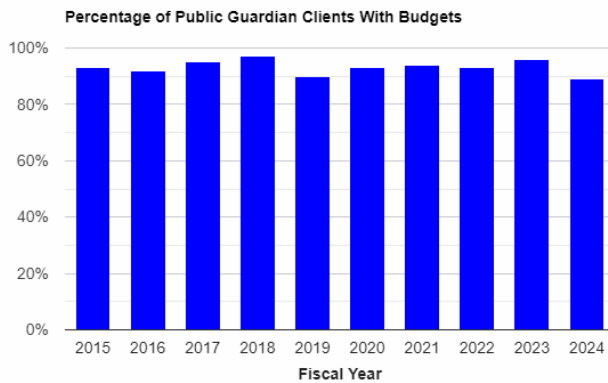
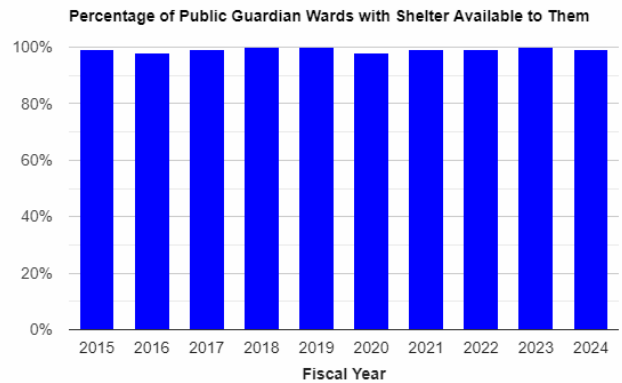

2. Guardian Ad Litem Services.

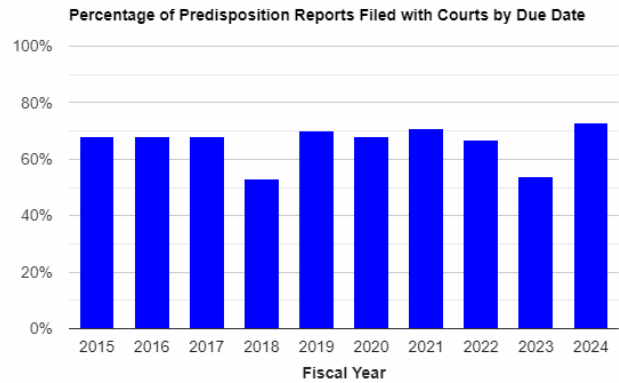
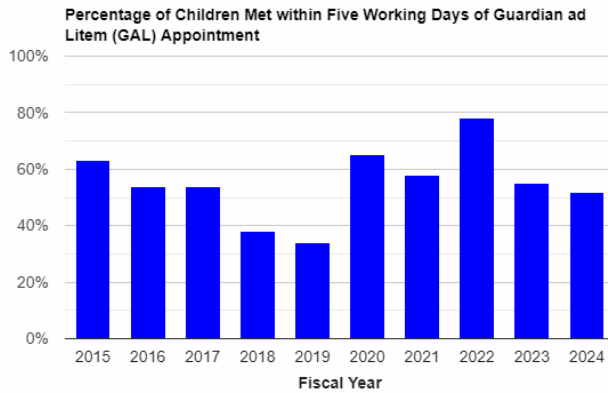

3. Elder Fraud Litigation.

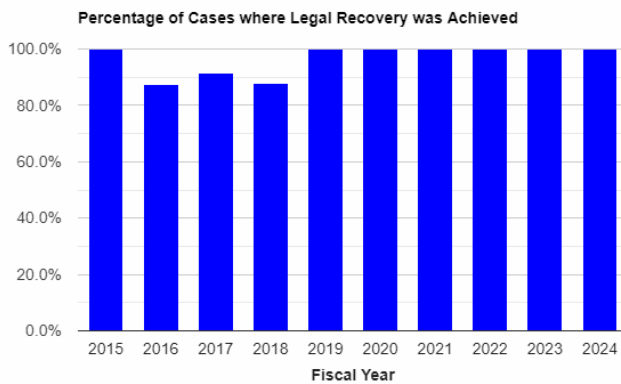

Major Component Accomplishments in 2024

- Minimized attrition despite a tight labor market and large trial case backlog.
- Drastically increased the number of class A and unclassified felony cases that were kept in-house, as opposed to being contracted to outside attorneys, to reduce criminal contractor costs.
- Increased contractor rates of pay to attract additional qualified independent contractors.
- Continued to conduct numerous jury trials to tackle case backlogs.
- Completed the reorganization of the public guardian section to increase efficiency and added additional PCNs to address caseload issues.
- Actively and successfully continued to challenge improper appointments by the Court.

Key Component Challenges

Growing Caseload – Due to the inherently unpredictable nature of the multiple types of caseloads, it is a significant challenge to maintain and provide core services to clients as efficiently as possible. The Office of Public Advocacy (OPA) is primarily a “down flow” agency in that it reacts to the actions of the other State agencies and systems (i.e., the Public Defender Agency, the Office of Children’s Services, Adult Protective Services, the Attorney General Human Services section, the District Attorney’s Office, the Court System, and other public and private entities). As a result, the unpredictability of caseload assignments makes it difficult to accurately forecast caseload increases and costs for upcoming budget years.

Criminal Trial Cases – The OPA experienced a substantial increase in criminal trial caseload due to the COVID case backlog. This, combined with various recently passed crime bills, will continue to strain the agency. The OPA is working to keep as many cases in-house as possible, but volume of cases necessitates use of private contract attorneys due to conflicts of interest and case overloads. The OPA cannot legally refuse cases.

Increase in Juvenile Delinquency Cases – There has been an unexpected increase in juvenile delinquency cases over the last several years.

- There has been a 200 percent increase from FY2020 to FY2024.

This trend appears consistent, and it is outstripping the agency's ability to place cases within existing resources.

Significant Caseload Increases for Public Guardians – The Public Guardian section continued to experience significant caseload increases. Since the start of 2013, the caseload has steadily increased totaling an additional 285 clients annually. Currently, the agency is approaching 1,800 wards. Many Guardians still carry caseloads with more than 80 cases with the senior Guardians carrying caseloads hovering at 100 wards. Moreover, as the Alaskan population ages (silver tidal wave), the number of wards assigned to the agency will expand every year for the foreseeable future. The COVID Federal Health Emergency Declaration was lifted mid-January 2023. This declaration drastically reduced the need for renewal applications to be filed as benefit for wards expired. The OPA eligibility technicians will soon be tasked with filing an additional 290 benefit renewal applications on top of their current workload.

Thus, increased ward/case numbers will remain a challenge for FY2025. To help address this challenge, the OPA has reorganized its Public Guardian section by creating a multi-tiered single job class while simultaneously restructuring how the section is supervised. This growth is also straining the OPA criminal and Child in Need of Aid (CINA) attorneys who are also required to represent any person who is potentially being placed under a guardianship. The OPA is also expanding the benefits sub-section of the public guardian which has become vital to reducing the felt workload in the section.

The Public Guardian section has not had any additional resignations as of the writing of this narrative. However, the workload remains intense, and the situation remains fragile. It takes approximately two years to train and certify public guardians and at least five years before they begin to master certain aspects of the job. Thus, retaining newly hired and trained public guardians is paramount

Excessive Burden on Guardians Ad Litem (GALs) – Increased appointments from the Alaska Court System may be related to budgetary concerns. For example, the Alaska Court System recently cut its custody investigator program. The OPA is concerned that GALs may be improperly substituted by the court to fill this role. The OPA has continued to see increased appointments of GALs in civil non-CINA cases into FY2024, but the numbers vary by jurisdiction due to differences in CINA practice.

Significant Changes in Results to be Delivered in FY2026

Cost Efficiency Matters – The OPA has strict cost control procedures in place requiring Director or Deputy approval for virtually all expenditures. All expenditures, whether for supplies, investigators or expert witnesses must be clearly justified to be approved. The OPA closely reviews all appointments received and works to limit the number of cases sent to private contractors, which in turn helps stabilize the budget and reduce overall expenses. The OPA actively files motions to vacate inappropriate appointments sent by the court.

Child Advocacy Caseloads – The agency will continue entering appropriate partnerships with community groups to expand the National Court Appointed Special Advocate (CASA) program and specifically target Alaska Native CASA volunteers for recruitment to continue to assist the GAL with their increased caseloads. The OPA is currently in discussions with several tribes to forge a collaborative arrangement and recruit CASA volunteers for both State and Tribal courts.

Should the Office of Child Services (OCS) increase its filings, then GAL caseloads will necessarily increase. The OPA is also concerned with improper GAL appointments by the court, particularly in civil custody cases as discussed above. Any appointments outside of OPAs enabling statute must be challenged to prevent straining already limited resources. It is challenging to predict caseloads for FY2025 as OCS and Attorney General (AG) staffing challenges continue to impact how resource intensive CINA litigation will be in the near future. Some

jurisdictions have become exceedingly litigious and adversarial while others are able to resolve cases in a timelier manner.

Criminal Defense Caseloads – In an effort to address the COVID case backlog, the court system has scheduled numerous jury trials well into FY2025. The increase in trial cases hampers OPA’s small section’s ability to meet the obligations of current and incoming cases. The OPA will continue to strive to meet its constitutional obligations and will continue to work diligently with the Department of Administration Commissioner and Deputy Commissioner to face these challenges and find creative solutions whenever possible.

Statutory and Regulatory Authority

AS 44.21.400 et seq. Office of Public Advocacy
2 AAC 60 et seq. Office of Public Advocacy

| Contact Information |
|--|
| <p>Contact: James Stinson, Division Director Phone: (907) 269-3500 E-mail: james.stinson@alaska.gov</p> |

| Office of Public Advocacy Personal Services Information | | | | |
|--|------------------------------|--------------------|----------------------------------|--------------------|
| Authorized Positions | | | Personal Services Costs | |
| | FY2025 Management Plan | FY2026 Governor | | |
| Full-time | 182 | 185 | Annual Salaries | 20,487,334 |
| Part-time | 2 | 2 | COLA | 560,192 |
| Nonpermanent | 12 | 12 | Premium Pay | 511,922 |
| | | | Annual Benefits | 12,321,162 |
| | | | <i>Less 7.00% Vacancy Factor</i> | <i>(2,372,910)</i> |
| | | | Lump Sum Premium Pay | 0 |
| Totals | 196 | 199 | Total Personal Services | 31,507,700 |

| Position Classification Summary | | | | | |
|---------------------------------|------------|-----------|-----------|-----------|------------|
| Job Class Title | Anchorage | Fairbanks | Juneau | Others | Total |
| Accountant 4 | 1 | 0 | 0 | 0 | 1 |
| Accounting Technician 1 | 1 | 0 | 0 | 0 | 1 |
| Accounting Technician 2 | 1 | 0 | 0 | 0 | 1 |
| Accounting Technician 3 | 2 | 0 | 0 | 0 | 2 |
| Administrative Assistant 1 | 1 | 0 | 0 | 0 | 1 |
| Administrative Officer 1 | 2 | 0 | 0 | 0 | 2 |
| Associate Attorney 2 | 12 | 3 | 2 | 4 | 21 |
| Attorney 1 | 1 | 0 | 0 | 0 | 1 |
| Attorney 2 | 2 | 0 | 0 | 2 | 4 |
| Attorney 3 | 4 | 1 | 1 | 0 | 6 |
| Attorney 4 | 26 | 5 | 0 | 6 | 37 |
| Attorney 5 | 11 | 3 | 2 | 4 | 20 |
| Attorney 6 | 2 | 0 | 0 | 0 | 2 |
| Division Director - Px | 1 | 0 | 0 | 0 | 1 |
| Eligibility Technician 2 | 2 | 0 | 0 | 0 | 2 |
| Eligibility Technician 3 | 1 | 0 | 0 | 0 | 1 |
| Investigator 2 | 1 | 1 | 0 | 0 | 2 |
| Investigator 3 | 4 | 1 | 1 | 1 | 7 |
| Law Office Assistant 1 | 3 | 1 | 1 | 0 | 5 |
| Law Office Assistant 2 | 6 | 2 | 1 | 4 | 13 |
| Law Office Assistant 3 | 1 | 0 | 0 | 0 | 1 |
| Office Assistant 1 | 1 | 0 | 0 | 2 | 3 |
| Office Assistant 2 | 2 | 0 | 0 | 0 | 2 |
| Paralegal 1 | 2 | 0 | 1 | 2 | 5 |
| Paralegal 2 | 8 | 3 | 0 | 2 | 13 |
| Paralegal 3 | 2 | 0 | 0 | 0 | 2 |
| Paralegal Specialist 1 | 2 | 0 | 0 | 0 | 2 |
| Program Coordinator 1 | 1 | 0 | 0 | 0 | 1 |
| Project Assistant | 1 | 1 | 1 | 1 | 4 |
| Public Guardian 1 | 5 | 0 | 1 | 0 | 6 |
| Public Guardian 2 | 15 | 3 | 1 | 2 | 21 |
| Public Guardian 3 | 5 | 0 | 1 | 2 | 8 |
| Public Guardian 4 | 1 | 0 | 0 | 0 | 1 |
| Totals | 130 | 24 | 13 | 32 | 199 |

Component Detail All Funds
Department of Administration

Component: Office of Public Advocacy (43)
RDU: Legal and Advocacy Services (11)

Non-Formula Component

| | FY2024 Actuals | FY2025 Enrolled | FY2025 Authorized | FY2025 Management Plan | FY2026 Governor Adjusted Base | FY2026 Governor | FY2025 Management Plan vs FY2026 Governor | |
|-----------------------------------|-----------------|-----------------|-------------------|------------------------|-------------------------------|-----------------|---|--------------|
| 1000 Personal Services | 26,499.6 | 27,846.6 | 29,685.0 | 29,685.0 | 30,617.4 | 31,507.7 | 1,822.7 | 6.1% |
| 2000 Travel | 289.5 | 322.8 | 328.3 | 322.8 | 322.8 | 328.3 | 5.5 | 1.7% |
| 3000 Services | 10,893.4 | 10,993.8 | 11,876.1 | 11,881.6 | 11,056.6 | 11,224.9 | -656.7 | -5.5% |
| 4000 Commodities | 338.6 | 239.0 | 246.0 | 246.0 | 246.0 | 251.5 | 5.5 | 2.2% |
| 5000 Capital Outlay | 0.0 | 0.0 | 0.0 | 0.0 | 0.0 | 0.0 | 0.0 | 0.0% |
| 7000 Grants, Benefits | 0.0 | 0.0 | 0.0 | 0.0 | 0.0 | 0.0 | 0.0 | 0.0% |
| 8000 Miscellaneous | 0.0 | 229.5 | 0.0 | 0.0 | 0.0 | 0.0 | 0.0 | 0.0% |
| Totals | 38,021.1 | 39,631.7 | 42,135.4 | 42,135.4 | 42,242.8 | 43,312.4 | 1,177.0 | 2.8% |
| Fund Sources: | | | | | | | | |
| 1002 Fed Rcpts (Fed) | 0.0 | 50.0 | 50.0 | 50.0 | 50.0 | 50.0 | 0.0 | 0.0% |
| 1003 GF/Match (UGF) | 250.0 | 250.0 | 250.0 | 250.0 | 250.0 | 250.0 | 0.0 | 0.0% |
| 1004 Gen Fund (UGF) | 32,646.5 | 34,195.2 | 36,600.0 | 36,600.0 | 36,615.1 | 37,684.7 | 1,084.7 | 3.0% |
| 1005 GF/Prgm (DGF) | 1,935.9 | 2,049.0 | 2,049.0 | 2,049.0 | 2,093.0 | 2,093.0 | 44.0 | 2.1% |
| 1007 I/A Rcpts (Other) | 805.7 | 529.2 | 529.2 | 529.2 | 534.4 | 534.4 | 5.2 | 1.0% |
| 1037 GF/MH (UGF) | 2,244.3 | 2,318.6 | 2,417.5 | 2,417.5 | 2,468.6 | 2,468.6 | 51.1 | 2.1% |
| 1092 MHTAAR (Other) | 138.7 | 239.7 | 239.7 | 239.7 | 231.7 | 231.7 | -8.0 | -3.3% |
| Unrestricted General (UGF) | 35,140.8 | 36,763.8 | 39,267.5 | 39,267.5 | 39,333.7 | 40,403.3 | 1,135.8 | 2.9% |
| Designated General (DGF) | 1,935.9 | 2,049.0 | 2,049.0 | 2,049.0 | 2,093.0 | 2,093.0 | 44.0 | 2.1% |
| Other Funds | 944.4 | 768.9 | 768.9 | 768.9 | 766.1 | 766.1 | -2.8 | -0.4% |
| Federal Funds | 0.0 | 50.0 | 50.0 | 50.0 | 50.0 | 50.0 | 0.0 | 0.0% |
| Positions: | | | | | | | | |
| Permanent Full Time | 176 | 180 | 182 | 182 | 182 | 185 | 3 | 1.6% |
| Permanent Part Time | 2 | 2 | 2 | 2 | 2 | 2 | 0 | 0.0% |
| Non Permanent | 12 | 12 | 12 | 12 | 12 | 12 | 0 | 0.0% |

Change Record Detail - Multiple Scenarios with Descriptions
Department of Administration

Component: Office of Public Advocacy (43)
RDU: Legal and Advocacy Services (11)

| Scenario/Change Record Title | Trans Type | Totals | Personal Services | Travel | Services | Commodities | Capital Outlay | Grants, Benefits | Miscellaneous | Positions | | NP |
|--|------------|----------|-------------------|--------|----------|-------------|----------------|------------------|---------------|-----------|-----|----|
| | | | | | | | | | | PFT | PPT | |
| ***** Changes From FY2025 Enrolled To FY2025 Authorized ***** | | | | | | | | | | | | |
| FY2025 Enrolled | Enrolled | 39,631.7 | 27,846.6 | 322.8 | 10,993.8 | 239.0 | 0.0 | 0.0 | 229.5 | 180 | 2 | 12 |
| 1002 Fed Rcpts | | 50.0 | | | | | | | | | | |
| 1003 GF/Match | | 250.0 | | | | | | | | | | |
| 1004 Gen Fund | | 34,195.2 | | | | | | | | | | |
| 1005 GF/Prgm | | 2,049.0 | | | | | | | | | | |
| 1007 I/A Rcpts | | 529.2 | | | | | | | | | | |
| 1037 GF/MH | | 2,318.6 | | | | | | | | | | |
| 1092 MHTAAR | | 239.7 | | | | | | | | | | |
| Compensation for Certain State Employees Ch5 SLA2024 (SB259) (Sec2 Ch7 SLA2024 P51 L24 (HB268)) | | | | | | | | | | | | |
| 1004 Gen Fund | FisNot | 671.7 | 671.7 | 0.0 | 0.0 | 0.0 | 0.0 | 0.0 | 0.0 | 0 | 0 | 0 |
| Five percent cost of living adjustment for employees not covered by a collective bargaining unit.: \$671.7 | | | | | | | | | | | | |
| Compensation for Certain State Employees Ch5 SLA2024 (SB259) (Sec2 Ch7 SLA2024 P51 L24 (HB268)) | | | | | | | | | | | | |
| 1004 Gen Fund | FisNot | 475.4 | 475.4 | 0.0 | 0.0 | 0.0 | 0.0 | 0.0 | 0.0 | 0 | 0 | 0 |
| One salary step adjustment for employees not covered by a collective bargaining agreement.: \$475.4 | | | | | | | | | | | | |
| Compensation for Certain State Employees Ch5 SLA2024 (SB259) (Sec2 Ch9 SLA2024 P8 L13 (HB270)) | | | | | | | | | | | | |
| 1037 GF/MH | FisNot | 58.0 | 58.0 | 0.0 | 0.0 | 0.0 | 0.0 | 0.0 | 0.0 | 0 | 0 | 0 |
| Five percent cost of living adjustment for employees not covered by a collective bargaining unit.: \$58.0 | | | | | | | | | | | | |
| Compensation for Certain State Employees Ch5 SLA2024 (SB259) (Sec2 Ch9 SLA2024 P8 L13 (HB270)) | | | | | | | | | | | | |
| 1037 GF/MH | FisNot | 40.9 | 40.9 | 0.0 | 0.0 | 0.0 | 0.0 | 0.0 | 0.0 | 0 | 0 | 0 |
| One salary step adjustment for employees not covered by a collective bargaining agreement.: \$40.9 | | | | | | | | | | | | |
| Omnibus Criminal Law/Procedure; Civil Commitment Ch11 SLA2024 (HB66) (Sec2 Ch7 SLA2024 P45 L22 (HB268)) | | | | | | | | | | | | |
| 1004 Gen Fund | FisNot | 432.7 | 362.9 | 5.5 | 57.3 | 7.0 | 0.0 | 0.0 | 0.0 | 2 | 0 | 0 |

This bill incorporates several changes to criminal statutes and procedures previously introduced as independent legislative action and this fiscal note incorporates the combined fiscal impacts on the Agency.

Change Record Detail - Multiple Scenarios with Descriptions
Department of Administration

Component: Office of Public Advocacy (43)
RDU: Legal and Advocacy Services (11)

| Scenario/Change Record Title | Trans Type | Totals | Personal Services | Travel | Services | Commodities | Capital Outlay | Grants, Benefits | Miscellaneous | Positions | | |
|------------------------------|------------|--------|-------------------|--------|----------|-------------|----------------|------------------|---------------|-----------|-----|----|
| | | | | | | | | | | PFT | PPT | NP |

This bill establishes a new murder charge where a person manufactures or delivers a controlled substance, and a person dies as a direct result of taking the illegal drugs. The bill allows the presentation of hearsay evidence at grand jury and increases sex offender registry and makes modifications to sex trafficking statutes. Registry requirements are a significant factor in assessing litigation strategies and options for the accused and may increase the number of cases that are brought to trial rather than resolved through plea agreements. This legislation creates a two-year commitment term for individuals determined mentally incompetent to stand trial in felony prosecutions. Additionally, this bill changes replaces the term "child pornography" with "sexual abuse material."

The following positions are added to the Public Advocacy:

Full-time Law Office Assistant 2 (02#263), range 13, located in Anchorage
 Full-time Attorney 4 (02#264), range 24, located in Anchorage

Align Authority for Anticipated Expenditures

| | | | | | | | | | | | | |
|-----|-----|-------|-----|-----|-----|-----|-----|-----|--------|---|---|---|
| LIT | 0.0 | 229.5 | 0.0 | 0.0 | 0.0 | 0.0 | 0.0 | 0.0 | -229.5 | 0 | 0 | 0 |
|-----|-----|-------|-----|-----|-----|-----|-----|-----|--------|---|---|---|

Allocate authority recorded on the miscellaneous line to personal services to reflect anticipated expenditures.

OPA One-time Case Backlog Contractor Support Sec13(b) Ch7 SLA2024 P88 L29 (HB268) (FY23-FY25)

| | | | | | | | | | | | | |
|---------------|----------|-------|-----|-----|-------|-----|-----|-----|-----|---|---|---|
| 1004 Gen Fund | CarryFwd | 825.0 | 0.0 | 0.0 | 825.0 | 0.0 | 0.0 | 0.0 | 0.0 | 0 | 0 | 0 |
| | | 825.0 | | | | | | | | | | |

* Sec. 13. DEPARTMENT OF ADMINISTRATION.

(b) The sum of \$825,000 is appropriated from the general fund to the Department of Administration, legal and advocacy services, office of public advocacy, to address case backlogs for the fiscal years ending June 30, 2024, and June 30, 2025.

| | | | | | | | | | | | | |
|-----------------|-----------------|-----------------|--------------|-----------------|--------------|------------|------------|------------|------------|------------|----------|-----------|
| Subtotal | 42,135.4 | 29,685.0 | 328.3 | 11,876.1 | 246.0 | 0.0 | 0.0 | 0.0 | 0.0 | 182 | 2 | 12 |
|-----------------|-----------------|-----------------|--------------|-----------------|--------------|------------|------------|------------|------------|------------|----------|-----------|

***** **Changes From FY2025 Authorized To FY2025 Management Plan** *****

Align Authority for Anticipated Expenditures

| | | | | | | | | | | | | |
|-----|-----|-----|------|-----|-----|-----|-----|-----|-----|---|---|---|
| LIT | 0.0 | 0.0 | -5.5 | 5.5 | 0.0 | 0.0 | 0.0 | 0.0 | 0.0 | 0 | 0 | 0 |
|-----|-----|-----|------|-----|-----|-----|-----|-----|-----|---|---|---|

Transfer authority from travel to cover anticipated services costs. The remaining personal services authority is sufficient to cover anticipated expenditures.

| | | | | | | | | | | | | |
|-----------------|-----------------|-----------------|--------------|-----------------|--------------|------------|------------|------------|------------|------------|----------|-----------|
| Subtotal | 42,135.4 | 29,685.0 | 322.8 | 11,881.6 | 246.0 | 0.0 | 0.0 | 0.0 | 0.0 | 182 | 2 | 12 |
|-----------------|-----------------|-----------------|--------------|-----------------|--------------|------------|------------|------------|------------|------------|----------|-----------|

***** **Changes From FY2025 Management Plan To FY2026 Governor Adjusted Base** *****

Reverse MH Trust: Salary Adjustments

| | | | | | | | | | | | | |
|-------------|-----|-------|-------|-----|-----|-----|-----|-----|-----|---|---|---|
| 1092 MHTAAR | OTI | -10.2 | -10.2 | 0.0 | 0.0 | 0.0 | 0.0 | 0.0 | 0.0 | 0 | 0 | 0 |
| | | -10.2 | | | | | | | | | | |

Reverse salary adjustments for positions supported with Mental Health Trust Authority Authorized Receipts (MHTAAR).

Reverse MH Trust: Public Guardian Position (FY19-FY25)

Change Record Detail - Multiple Scenarios with Descriptions
Department of Administration

Component: Office of Public Advocacy (43)
RDU: Legal and Advocacy Services (11)

| Scenario/Change Record Title | Trans Type | Totals | Personal Services | Travel | Services | Commodities | Capital Outlay | Grants, Benefits | Miscellaneous | Positions | | |
|------------------------------|------------|--------|-------------------|--------|----------|-------------|----------------|------------------|---------------|-----------|-----|----|
| | | | | | | | | | | PFT | PPT | NP |
| 1092 MHTAAR | OTI | -91.5 | -91.5 | 0.0 | 0.0 | 0.0 | 0.0 | 0.0 | 0.0 | 0 | 0 | 0 |

Trust funds will be used to support a Public Guardian position in the Department of Administration, Office of Public Advocacy (OPA). The position is in Anchorage and serves the Western Alaska region including Bethel, Dillingham, Naknek, and surrounding communities. Public guardians serve adult Trust beneficiaries found by the Superior court to be incapacitated. Public guardians are required to maintain benefits, manage finances, make medical decisions, and ensure suitable housing for each Trust beneficiary. Assisting Trust beneficiaries with these needs improves public protection and State resource management by giving them the ability to live safely in their communities rather than in State hospitals or even correctional institutions. This position supports the OPA's strategic plan to bring down current public guardian caseloads from approximately 100 cases per public guardian to the recommended national maximum of 40 case per public guardian, resulting in improved services, supports, and overall management of Trust beneficiaries.

Reverse MH Trust: Public Guardian Position - Office of Child Services Transition (FY24-FY27)

| | | | | | | | | | | | | |
|-------------|-----|--------|--------|-----|-----|-----|-----|-----|-----|---|---|---|
| 1092 MHTAAR | OTI | -138.0 | -138.0 | 0.0 | 0.0 | 0.0 | 0.0 | 0.0 | 0.0 | 0 | 0 | 0 |
|-------------|-----|--------|--------|-----|-----|-----|-----|-----|-----|---|---|---|

Trust funds will be used to support a Public Guardian position in the Department of Administration, Office of Public Advocacy (OPA). Public guardians serve adult Trust beneficiaries found by the Superior court to be incapacitated. Public guardians are required to maintain benefits, manage finances, make medical decisions, and ensure suitable housing for each Trust beneficiary. Assisting Trust beneficiaries with these needs improves public protection and State resource management by giving them the ability to live safely in their communities rather than in State hospitals or even correctional institutions. The position is in Anchorage and works statewide with Trust beneficiaries who are aging out of the OCS system. This position supports the OPA's strategic plan to bring down current public guardian caseloads from approximately 100 cases per public guardian to the recommended national maximum of 40 case per public guardian, resulting in improved services, supports, and overall management of Trust beneficiaries.

Reverse One-Time Case Backlog Contractor Support Sec13(b) Ch7 SLA2024 P88 L29 (HB268) (FY23-FY25)

| | | | | | | | | | | | | |
|---------------|-----|--------|-----|-----|--------|-----|-----|-----|-----|---|---|---|
| 1004 Gen Fund | OTI | -825.0 | 0.0 | 0.0 | -825.0 | 0.0 | 0.0 | 0.0 | 0.0 | 0 | 0 | 0 |
|---------------|-----|--------|-----|-----|--------|-----|-----|-----|-----|---|---|---|

* Sec. 13. DEPARTMENT OF ADMINISTRATION.

(b) The sum of \$825,000 is appropriated from the general fund to the Department of Administration, legal and advocacy services, office of public advocacy, to address case backlogs for the fiscal years ending June 30, 2024, and June 30, 2025.

MH Trust: Public Guardian Position (FY19-FY27)

| | | | | | | | | | | | | |
|-------------|------|-------|-------|-----|-----|-----|-----|-----|-----|---|---|---|
| 1092 MHTAAR | IncT | 138.0 | 138.0 | 0.0 | 0.0 | 0.0 | 0.0 | 0.0 | 0.0 | 0 | 0 | 0 |
|-------------|------|-------|-------|-----|-----|-----|-----|-----|-----|---|---|---|

Trust funds will be used to support a new Public Guardian position in the Department of Administration, Office of Public Advocacy. The position will be located in Anchorage and will serve the Western Alaska region, including Bethel, Dillingham, and Utqiagvik. Public guardians serve adults Trust beneficiaries found to be incapacitated by the Superior court. Public guardians are required to maintain benefits, manage finances, make medical decisions, and ensure suitable housing for each Trust beneficiary (ward). This position supports the Office of Public Advocacy's strategic plan to bring down current public guardian caseloads from approximately 100 cases per public guardian to the recommended national maximum of 40 cases per public guardian, resulting in improved services, support, and overall management of Trust beneficiaries (wards).

Change Record Detail - Multiple Scenarios with Descriptions
Department of Administration

Component: Office of Public Advocacy (43)
RDU: Legal and Advocacy Services (11)

| Scenario/Change Record Title | Trans Type | Totals | Personal Services | Travel | Services | Commodities | Capital Outlay | Grants, Benefits | Miscellaneous | Positions | | |
|--|-----------------|-----------------|-------------------|--------------|-----------------|--------------|----------------|------------------|---------------|------------|----------|-----------|
| | | | | | | | | | | PFT | PPT | NP |
| MH Trust: Public Guardian Position - Office of Child Services Transition (FY24-FY27) | | | | | | | | | | | | |
| 1092 MHTAAR | IncT | 91.5 | 91.5 | 0.0 | 0.0 | 0.0 | 0.0 | 0.0 | 0.0 | 0 | 0 | 0 |
| Trust funds will be used to support a new Public Guardian position in the Department of Administration, Office of Public Advocacy, to work directly with Trust beneficiaries who are aging out of the child welfare system. The position will be located in Anchorage and will serve the beneficiaries statewide. Public guardians serve adults Trust beneficiaries found to be incapacitated by the Superior court. Public guardians are required to maintain benefits, manage finances, make medical decisions, and ensure suitable housing for each Trust beneficiary (ward). This position supports the Office of Public Advocacy's strategic plan to bring down current public guardian caseloads from approximately 100 cases per public guardian to the recommended national maximum of 40 cases per public guardian, resulting in improved services, support, and overall management of Trust beneficiaries (wards). | | | | | | | | | | | | |
| FY2026 Salary, Health Insurance, and Retirement Increases | | | | | | | | | | | | |
| | SalAdj | 942.6 | 942.6 | 0.0 | 0.0 | 0.0 | 0.0 | 0.0 | 0.0 | 0 | 0 | 0 |
| 1004 Gen Fund | | 840.1 | | | | | | | | | | |
| 1005 GF/Prgm | | 44.0 | | | | | | | | | | |
| 1007 I/A Rcpts | | 5.2 | | | | | | | | | | |
| 1037 GF/MH | | 51.1 | | | | | | | | | | |
| 1092 MHTAAR | | 2.2 | | | | | | | | | | |
| Salary, health and retirement increases: \$942.6 | | | | | | | | | | | | |
| AlaskaCare increase from \$1908 to \$2030.11 per member per month: \$133.4 | | | | | | | | | | | | |
| FY2026 APEA (non-law enforcement) 3% cost of living adjustment: \$24.0 | | | | | | | | | | | | |
| FY2026 3% cost of living adjustment for employees not covered by a collective bargaining agreement: \$493.5 | | | | | | | | | | | | |
| FY2026 PERS rate adjustment from 26.76% to 28.33%: \$291.7 | | | | | | | | | | | | |
| | Subtotal | 42,242.8 | 30,617.4 | 322.8 | 11,056.6 | 246.0 | 0.0 | 0.0 | 0.0 | 182 | 2 | 12 |

***** **Changes From FY2026 Governor Adjusted Base To FY2026 Governor** *****

| | | | | | | | | | | | | |
|---|-----|-------|-------|-----|------|-----|-----|-----|-----|---|---|---|
| Add One Administrative Support to Help Keep Pace with Expanding Operations | | | | | | | | | | | | |
| 1004 Gen Fund | Inc | 143.3 | 143.3 | 0.0 | 17.3 | 1.0 | 0.0 | 0.0 | 0.0 | 1 | 0 | 0 |

The administrative positions within Office of Public Advocacy (OPA) have remained stagnant and are struggling to keep pace with the administrative demands.

The OPA is organized as multiple independent law firms under one central administrative umbrella. This unique structure depends on the central administrative support to be functioning well.

These sections depend on the OPA's administrative support for essential tasks like creating and transferring positions, hiring, promotions, tech issues, placing

Change Record Detail - Multiple Scenarios with Descriptions
Department of Administration

Component: Office of Public Advocacy (43)
RDU: Legal and Advocacy Services (11)

| Scenario/Change Record Title | Trans Type | Totals | Personal Services | Travel | Services | Commodities | Capital Outlay | Grants, Benefits | Miscellaneous | Positions | | NP |
|---|------------|--------|-------------------|--------|----------|-------------|----------------|------------------|---------------|-----------|-----|----|
| | | | | | | | | | | PFT | PPT | |
| civil and criminal cases, billing, paying agency and contractor bills, auditing, managing public guardian client funds, etc. The agency is currently struggling to fulfil the existing administrative duties due to understaffing, which is hindering the efficiency of the agency as whole and allowing critical issues to be overlooked. | | | | | | | | | | | | |
| Full-time Administrative Officer 1 (02#296), range 17, located in Anchorage | | | | | | | | | | | | |
| Guardian ad Litem Positions Becoming Overtime Eligible | | | | | | | | | | | | |
| | Inc | 450.0 | 450.0 | 0.0 | 0.0 | 0.0 | 0.0 | 0.0 | 0.0 | 0 | 0 | 0 |
| 1004 Gen Fund | | 450.0 | | | | | | | | | | |
| This funding will cover overtime for Guardian ad Litem and Public Guardian positions, which advocate for Children in Need of Aid (CINA) cases. These positions operate on attorney hours and essentially practice law under a CINA court rules exception. | | | | | | | | | | | | |
| A recent change in job classification now allows this position class to log and bill overtime hours for work beyond the standard 40-hour workweek. Previously, these positions often worked more than 40 hours to serve indigent Alaskans without overtime eligibility. This change is expected to improve recruitment, retention, service delivery, and customer satisfaction. | | | | | | | | | | | | |
| Add One Paralegal to Reduce Congestion in Assigning Statewide Cases | | | | | | | | | | | | |
| | Inc | 128.0 | 109.7 | 0.0 | 17.3 | 1.0 | 0.0 | 0.0 | 0.0 | 1 | 0 | 0 |
| 1004 Gen Fund | | 128.0 | | | | | | | | | | |
| The Office of Public Advocacy currently has three paralegals tasked with assigning cases statewide, with two additional paralegals who handle case assignments for their individual small regional offices. In one month, the three statewide paralegals assigned 570 cases, which works out to about nine cases for each paralegal per day. Each assignment takes considerable work. This additional position will support the statewide case assignments team to prevent congestion and enhance the efficiency of the agency. | | | | | | | | | | | | |
| Assigning a single case takes considerable time and effort, and typically consists of: | | | | | | | | | | | | |
| - Extracting information from court case documents and recording it in one document | | | | | | | | | | | | |
| - Running all names through the database to find conflict-free counsel | | | | | | | | | | | | |
| - Identifying counsel-seeking contract attorneys if staff offices are conflicted and waiting on someone to accept the case | | | | | | | | | | | | |
| - Creating cases in the database to include entering all compiled names | | | | | | | | | | | | |
| - Transferring all discovery and pleadings to the assigned attorney Full-time Paralegal 2 (02#297), range 16, located in Anchorage | | | | | | | | | | | | |
| Add One Attorney 5 to Provide Legal Support and Leadership to the Public Guardians Section | | | | | | | | | | | | |
| | Inc | 242.3 | 205.6 | 5.5 | 27.7 | 3.5 | 0.0 | 0.0 | 0.0 | 1 | 0 | 0 |
| 1004 Gen Fund | | 242.3 | | | | | | | | | | |
| The Public Guardian section has expanded significantly to meet the demands of a growing client base, creating an urgent need for added leadership and legal support. | | | | | | | | | | | | |
| Currently, this section is the only one in the Office of Public Advocacy lacking an Attorney 5 supervisor. The areas of practice in this section are specialized and include pushing back against improper appointments, developing favorable caselaw, and protecting the agency from liability by working directly with the Public Guardian 4 supervisor on policies and procedures. This Attorney 5 position is a key component needed to stabilize the section in the long term. | | | | | | | | | | | | |

Change Record Detail - Multiple Scenarios with Descriptions
Department of Administration

Component: Office of Public Advocacy (43)
RDU: Legal and Advocacy Services (11)

| Scenario/Change Record Title | Trans Type | Totals | Personal Services | Travel | Services | Commodities | Capital Outlay | Grants, Benefits | Miscellaneous | Positions | | NP |
|--|---------------|-----------------|-------------------|--------------|-----------------|--------------|----------------|------------------|---------------|------------|----------|-----------|
| | | | | | | | | | | PFT | PPT | |
| Full-time Attorney 5 (02#298), range 25, located in Anchorage | | | | | | | | | | | | |
| Lease Costs Related to Capital Improvement Project for Building Upgrades for the Office of Public Advocacy | | | | | | | | | | | | |
| | Inc | 106.0 | 0.0 | 0.0 | 106.0 | 0.0 | 0.0 | 0.0 | 0.0 | 0 | 0 | 0 |
| 1004 Gen Fund | | 106.0 | | | | | | | | | | |
| The Office of Public Advocacy (OPA) needs building upgrades and renovations to their primary office space to upgrade out-of-date technological aspects of the building, including modernizing internet capabilities, and to accommodate the increased number of positions that have been created through fiscal notes and budget requests over the past few years. | | | | | | | | | | | | |
| This buildout will add appropriate office space for additional positions that have been added. | | | | | | | | | | | | |
| | Totals | 43,312.4 | 31,507.7 | 328.3 | 11,224.9 | 251.5 | 0.0 | 0.0 | 0.0 | 185 | 2 | 12 |

Line Item Detail (1676)
Department of Administration
Travel

Component: Office of Public Advocacy (43)

| Line Number | Line Name | | FY2024 Actuals | FY2025 Management Plan | FY2026 Governor |
|----------------------------------|----------------------------------|---|----------------|------------------------|-----------------|
| 2000 | Travel | | 289.5 | 322.8 | 328.3 |
| Object Class | Servicing Agency | Explanation | FY2024 Actuals | FY2025 Management Plan | FY2026 Governor |
| 2000 Travel Detail Totals | | | 289.5 | 322.8 | 328.3 |
| 2000 | In-State Employee Travel | Transportation costs for travel relating to administration, training, conventions and meetings, boards and commissions. | 274.1 | 310.0 | 308.1 |
| 2001 | In-State Non-Employee Travel | Transportation costs for travel relating to meetings and boards for non-employees. | 5.5 | 10.6 | 10.0 |
| 2002 | Out of State Employee Travel | Transportation costs for staff travel out of state to national organization meetings, conferences, and training. | 5.9 | 2.2 | 5.2 |
| 2003 | Out of State Non-Employee Travel | Transportation costs for travel relating to meetings, boards and commissions for non-employees | 1.1 | 0.0 | 4.0 |
| 2005 | Moving Costs | Moving and relocation costs. | 2.9 | 0.0 | 0.0 |
| 2006 | Other Travel Costs | Miscellaneous travel-related expenses. | 0.0 | 0.0 | 1.0 |

Line Item Detail (1676)
Department of Administration
Services

Component: Office of Public Advocacy (43)

| Line Number | Line Name | | FY2024 Actuals | FY2025 Management Plan | FY2026 Governor |
|------------------------------------|-----------------------------|--|-----------------|------------------------|-----------------|
| 3000 | Services | | 10,893.4 | 11,881.6 | 11,224.9 |
| Object Class | Servicing Agency | Explanation | FY2024 Actuals | FY2025 Management Plan | FY2026 Governor |
| 3000 Services Detail Totals | | | 10,893.4 | 11,881.6 | 11,224.9 |
| 3000 | Education Services | Training, educational conferences, agency memberships, and employee tuition. | 65.5 | 61.5 | 61.5 |
| 3001 | Financial Services | Management and consulting services. | 0.4 | 0.4 | 0.4 |
| 3002 | Legal and Judicial Services | Contract attorney expenditures related to appellate cases, expert witness fees, transcription services and miscellaneous case costs (medical record requests, etc.). This amount will vary year to year based on open cases, case complexity, court appointments, and attorney availability. | 7,037.5 | 7,405.3 | 6,673.0 |
| 3003 | Information Technology | Software licensing and maintenance, training, and consulting. | 69.9 | 91.9 | 91.9 |
| 3004 | Telecommunications | Local, long distance, and cellular telephone charges, television, data/network, telecommunication equipment, and other wireless charges from outside vendors. | 52.6 | 56.0 | 56.0 |
| 3006 | Delivery Services | Freight, courier services, and postage. | 134.7 | 136.0 | 136.0 |
| 3007 | Advertising and Promotions | Advertising, promotions and legal notices. | 0.5 | 0.0 | 0.0 |
| 3008 | Utilities | Electricity, heating fuel, water, sewage, and disposal services. | 17.6 | 20.0 | 20.0 |

Line Item Detail (1676)
Department of Administration
Services

Component: Office of Public Advocacy (43)

| Object Class | Servicing Agency | Explanation | FY2024 Actuals | FY2025 Management Plan | FY2026 Governor |
|------------------------------------|--|---|-----------------|---------------------------|-----------------|
| 3000 Services Detail Totals | | | 10,893.4 | 11,881.6 | 11,224.9 |
| 3009 | Structure/Infrastructure/Land | Structure, infrastructure and land repairs, maintenance, rental, and leases. | 198.6 | 200.0 | 200.0 |
| 3010 | Equipment/Machinery | Machinery, furniture and office equipment purchase, repairs, maintenance, rentals, and leases. | 164.7 | 175.0 | 175.0 |
| 3011 | Other Services | Miscellaneous services including interpreter services, fingerprinting. | 16.6 | 18.0 | 20.0 |
| 3017 | Inter-Agency Information Technology Non-Telecommunications | Admin - Chief Information Officer (3139) OIT Core Services. | 576.8 | 654.0 | 675.0 |
| 3018 | Inter-Agency Information Technology Telecommunications | OIT Telecommunications (CISCO device config, deployment, maintenance, replacements, and other telephone line services). | 56.5 | 60.0 | 60.0 |
| 3021 | Inter-Agency Mail | Admin - Print Services (2333) Centralized mail services chargeback. | 6.8 | 10.0 | 10.0 |
| 3022 | Inter-Agency Human Resources | Admin - Print Services (2333) Centralized Human Resource chargeback. | 110.3 | 150.0 | 200.0 |
| 3023 | Inter-Agency Building Leases | Trans - Department-wide Rent for state-owned facilities and lease payments. | 1,407.9 | 1,610.0 | 1,610.0 |
| 3024 | Inter-Agency Legal | Courts - Department-wide Department of Law / Public Guardian Legal Services. | 136.0 | 140.0 | 140.0 |
| 3024 | Inter-Agency Legal | Health - Department-wide Reimbursement for HCS Guardianship clients federal funding. | 250.0 | 250.0 | 250.0 |
| 3024 | Inter-Agency Legal | Law - Department-wide Legal services provided by the Department of Law. | 7.9 | 10.0 | 10.0 |
| 3026 | Inter-Agency Insurance | Admin - Risk Management (71) Division of Risk Management - Risk management insurance charges. | 7.8 | 9.0 | 9.0 |
| 3027 | Inter-Agency Financial | Admin - Accounting (3134) SSoA Accounts Payable and Travel chargeback. | 14.0 | 20.0 | 20.0 |
| 3027 | Inter-Agency Financial | Admin - Finance (59) Division of Finance chargeback for IRIS FIN, HRM, and ALDER. | 138.6 | 143.3 | 35.0 |

Line Item Detail (1676)
Department of Administration
Services

Component: Office of Public Advocacy (43)

| Object Class | | Servicing Agency | Explanation | FY2024 Actuals | FY2025 Management Plan | FY2026 Governor |
|------------------------------------|---|---|--|-----------------|------------------------|-----------------|
| 3000 Services Detail Totals | | | | 10,893.4 | 11,881.6 | 11,224.9 |
| 3028 | Inter-Agency Americans with Disabilities Act Compliance | Admin - Personnel (56) | Americans with Disabilities Act (ADA) chargeback. | 2.6 | 5.0 | 5.0 |
| 3029 | Inter-Agency Education/Training | Admin - OFC of Procure. Property. Mngmt. (3291) | Internal department cost allocation chargeback, desktop support, procurement services. | 0.8 | 0.0 | 0.0 |
| 3038 | Inter-Agency Management/Consulting | Admin - Administrative Services (46) | Administrative chargeback. | 188.3 | 394.3 | 460.1 |
| 3038 | Inter-Agency Management/Consulting | Admin - OFC of Procure. Property. Mngmt. (3291) | SSoA Procurement chargeback. | 26.9 | 35.0 | 60.0 |
| 3038 | Inter-Agency Management/Consulting | Admin - Office of the Commissioner (45) | Office of the Commissioner chargeback. | 203.6 | 226.9 | 247.0 |

Line Item Detail (1676)
Department of Administration
Commodities

Component: Office of Public Advocacy (43)

| Line Number | Line Name | | FY2024 Actuals | FY2025 Management Plan | FY2026 Governor |
|---------------------------------------|-------------------------|--|-----------------------|-------------------------------|------------------------|
| 4000 | Commodities | | 338.6 | 246.0 | 251.5 |
| Object Class | Servicing Agency | Explanation | FY2024 Actuals | FY2025 Management Plan | FY2026 Governor |
| 4000 Commodities Detail Totals | | | 338.6 | 246.0 | 251.5 |
| 4000 | Business | General business supplies such as office consumables, furniture, and computer equipment. | 338.0 | 246.0 | 251.5 |
| 4002 | Household/Institutional | Cleaning, food and other household supplies. | 0.6 | 0.0 | 0.0 |

Revenue Detail (1681)
Department of Administration

Component: Office of Public Advocacy (43)

| Revenue Type (OMB Fund Code) Revenue Source | Component | Comment | FY2024 Actuals | FY2025 Management Plan | FY2026 Governor |
|--|------------------------|--|----------------|---------------------------|-----------------|
| 5002 Fed Rcpts (1002 Fed Rcpts) | | | 0.0 | 50.0 | 50.0 |
| 5014 Federal Public Protection - Miscellaneous Grants | | Federal Receipts. | 0.0 | 50.0 | 50.0 |
| 5005 GF/Prgm (1005 GF/Prgm) | | | 2,308.3 | 2,049.0 | 2,093.0 |
| 5102 Program Receipts Public Protection - Fines and Forfeitures | | Reimbursement of fees collected by the Department of Law (Rule 39). | 199.3 | 49.0 | 93.0 |
| 5103 Program Receipts - Charges for Services | | Public Guardian fees. | 2,109.0 | 2,000.0 | 2,000.0 |
| 5007 I/A Rcpts (1007 I/A Rcpts) | | | 805.7 | 760.9 | 534.4 |
| 5301 Inter-Agency Receipts | FCS - Department-wide | Reimbursable services agreement for Title IV federal reimbursement. | 305.7 | 260.9 | 260.9 |
| 5301 Inter-Agency Receipts | H&SS - Department-wide | Reimbursable services agreement for support for guardianship clients. | 500.0 | 500.0 | 273.5 |
| 6004 Gen Fund (1004 Gen Fund) | | | 8.4 | 2.0 | 2.0 |
| 6046 General Fund - Prior Year Reimbursement Recovery | | Prior year recovery. | 8.4 | 2.0 | 2.0 |

Inter-Agency Services (1682)
Department of Administration

Component: Office of Public Advocacy (43)

| | | | | FY2024 Actuals | FY2025 Management Plan | FY2026 Governor |
|--|---|---|---|---------------------------------------|---------------------------|-----------------|
| Component Totals | | | | 3,078.3 | 3,657.5 | 3,731.1 |
| With Department of Administration | | | | 1,276.5 | 1,647.5 | 1,721.1 |
| With Department of Transportation and Public Facilities | | | | 1,407.9 | 1,610.0 | 1,610.0 |
| With Judiciary | | | | 136.0 | 140.0 | 140.0 |
| With Department of Health | | | | 250.0 | 250.0 | 250.0 |
| With Department of Law | | | | 7.9 | 10.0 | 10.0 |
| Object Class | Servicing Agency | Explanation | | | | |
| | | | FY2024 Actuals | FY2025 Management Plan | FY2026 Governor | |
| 3017 | Inter-Agency Information Technology Non-Telecommunications | Admin - Chief Information Officer (3139) | OIT Core Services. | 576.8 | 654.0 | 675.0 |
| 3021 | Inter-Agency Mail | Admin - Print Services (2333) | Centralized mail services chargeback. | 6.8 | 10.0 | 10.0 |
| 3022 | Inter-Agency Human Resources | Admin - Print Services (2333) | Centralized Human Resource chargeback. | 110.3 | 150.0 | 200.0 |
| 3023 | Inter-Agency Building Leases | Trans - Department-wide | Rent for state-owned facilities and lease payments. | 1,407.9 | 1,610.0 | 1,610.0 |
| 3024 | Inter-Agency Legal | Courts - Department-wide | Department of Law / Public Guardian Legal Services. | 136.0 | 140.0 | 140.0 |
| 3024 | Inter-Agency Legal | Health - Department-wide | Reimbursement for HCS Guardianship clients federal funding. | 250.0 | 250.0 | 250.0 |
| 3024 | Inter-Agency Legal | Law - Department-wide | Legal services provided by the Department of Law. | 7.9 | 10.0 | 10.0 |
| 3026 | Inter-Agency Insurance | Admin - Risk Management (71) | Division of Risk Management - Risk management insurance charges. | 7.8 | 9.0 | 9.0 |
| 3027 | Inter-Agency Financial | Admin - Accounting (3134) | SSoA Accounts Payable and Travel chargeback. | 14.0 | 20.0 | 20.0 |
| 3027 | Inter-Agency Financial | Admin - Finance (59) | Division of Finance chargeback for IRIS FIN, HRM, and ALDER. | 138.6 | 143.3 | 35.0 |
| 3028 | Inter-Agency Americans with Disabilities Act Compliance | Admin - Personnel (56) | Americans with Disabilities Act (ADA) chargeback. | 2.6 | 5.0 | 5.0 |
| 3029 | Inter-Agency Education/Training | Admin - OFC of Procure. Property. | Internal department cost allocation | 0.8 | 0.0 | 0.0 |
| FY2026 Governor Department of Administration | | | | Released December 12, 2024 Page 20 | | |

Inter-Agency Services (1682)
Department of Administration

Component: Office of Public Advocacy (43)

| Object Class | | Servicing Agency | Explanation | FY2024 Actuals | FY2025 Management Plan | FY2026 Governor |
|--------------|------------------------------------|---|--|----------------|---------------------------|-----------------|
| | | Mngmt. (3291) | chargeback, desktop support, procurement services. | | | |
| 3038 | Inter-Agency Management/Consulting | Admin - Administrative Services (46) | Administrative chargeback. | 188.3 | 394.3 | 460.1 |
| 3038 | Inter-Agency Management/Consulting | Admin - OFC of Procure. Property. Mngmt. (3291) | SSoA Procurement chargeback. | 26.9 | 35.0 | 60.0 |
| 3038 | Inter-Agency Management/Consulting | Admin - Office of the Commissioner (45) | Office of the Commissioner chargeback. | 203.6 | 226.9 | 247.0 |

Personal Services Expenditure Detail
Department of Administration

Scenario: FY2026 Governor (22363)
Component: Office of Public Advocacy (43)
RDU: Legal and Advocacy Services (11)

| PCN | Job Class Title | Time Status | Retire Code | Barg Unit | Location | Salary Sched | Range / Step | Comp Months | Split / Count | Annual Salaries | COLA | Premium Pay | Annual Benefits | Total Costs | UGF Amount |
|--------|--------------------------|-------------|-------------|-----------|-----------|--------------|--------------|-------------|---------------|-----------------|-------|-------------|-----------------|-------------|------------|
| 02#296 | Administrative Officer 1 | FT | A | GP | Anchorage | 100 | 17C | 12.0 | | 67,412 | 0 | 0 | 46,507 | 113,919 | 113,919 |
| 02#297 | Paralegal 2 | FT | A | GP | Anchorage | 100 | 16C | 12.0 | | 62,654 | 0 | 0 | 44,571 | 107,225 | 107,225 |
| 02#298 | Attorney 5 | FT | A | XE | Anchorage | N00 | 25C | 12.0 | | 117,371 | 4,954 | 0 | 72,144 | 194,469 | 194,469 |
| 02?045 | Public Guardian 1 | FT | A | GP | Anchorage | 200 | 16A / B | 12.0 | | 60,138 | 0 | 12,027 | 48,442 | 120,607 | 107,340 |
| 02?046 | Public Guardian 1 | FT | A | GP | Anchorage | 200 | 16A / B | 12.0 | | 60,138 | 0 | 12,027 | 48,442 | 120,607 | 107,340 |
| 02?047 | Public Guardian 1 | FT | A | GP | Anchorage | 200 | 16A / B | 12.0 | | 60,138 | 0 | 12,027 | 48,442 | 120,607 | 107,340 |
| 02?048 | Public Guardian 1 | FT | A | GP | Anchorage | 200 | 16A / B | 12.0 | | 60,138 | 0 | 12,027 | 48,442 | 120,607 | 107,340 |
| 02?063 | Law Office Assistant 2 | FT | A | GP | Anchorage | 200 | 13A | 12.0 | | 47,307 | 0 | 0 | 38,325 | 85,632 | 85,632 |
| 02?064 | Attorney 4 | FT | A | XE | Anchorage | N00 | 24C | 12.0 | | 109,493 | 4,622 | 0 | 68,938 | 183,053 | 183,053 |
| 021136 | Investigator 3 | FT | A | SS | Anchorage | 600 | 18J | 12.0 | | 85,322 | 3,601 | 0 | 59,244 | 148,167 | 148,167 |
| 021257 | Attorney 4 | FT | A | XE | Palmer | A00 | 24F / J | 12.0 | | 139,769 | 5,900 | 0 | 81,260 | 226,929 | 226,929 |
| 021387 | Attorney 4 | FT | A | XE | Fairbanks | A03 | 24J | 12.0 | | 148,415 | 6,265 | 0 | 84,779 | 239,459 | 239,459 |
| 021555 | Public Guardian 2 | FT | A | GP | Anchorage | 200 | 18F / G | 12.0 | | 80,557 | 0 | 15,853 | 58,310 | 154,720 | 137,701 |
| 021556 | Public Guardian 2 | FT | A | GP | Anchorage | 200 | 18B / C | 12.0 | | 70,455 | 0 | 13,829 | 53,374 | 137,658 | 122,516 |
| 021557 | Public Guardian 2 | FT | A | GP | Palmer | 200 | 18A / B | 12.0 | | 68,832 | 0 | 13,357 | 52,522 | 134,711 | 119,893 |
| 021558 | Public Guardian 2 | FT | A | GP | Anchorage | 200 | 18A / B | 12.0 | | 68,832 | 0 | 0 | 47,085 | 115,917 | 103,166 |
| 021559 | Public Guardian 2 | FT | A | GP | Fairbanks | 203 | 18B / C | 12.0 | | 72,770 | 0 | 0 | 48,688 | 121,458 | 108,098 |
| 021560 | Public Guardian 1 | FT | A | GP | Juneau | 105 | 16A | 12.0 | | 61,406 | 0 | 12,281 | 49,061 | 122,748 | 88,620 |
| 021561 | Eligibility Technician 3 | FT | A | GP | Anchorage | 200 | 16C | 12.0 | | 62,069 | 0 | 0 | 44,333 | 106,402 | 76,819 |
| 021562 | Public Guardian 1 | FT | A | GP | Anchorage | 200 | 16A | 12.0 | | 57,974 | 0 | 11,594 | 47,385 | 116,953 | 84,437 |
| 021600 | Division Director - Px | FT | A | XE | Anchorage | A00 | 27S | 12.0 | | 221,910 | 8,959 | 0 | 111,810 | 342,679 | 308,411 |
| 021601 | Investigator 3 | FT | A | GP | Anchorage | 200 | 18D / E | 12.0 | | 75,079 | 0 | 0 | 49,628 | 124,707 | 124,707 |
| 021602 | Paralegal 2 | FT | A | GP | Anchorage | 200 | 16B / C | 12.0 | | 60,910 | 0 | 1,387 | 44,426 | 106,723 | 106,723 |
| 021603 | Law Office Assistant 1 | FT | A | GP | Anchorage | 200 | 11B / C | 12.0 | | 44,127 | 0 | 0 | 37,030 | 81,157 | 81,157 |
| 021604 | Associate Attorney 2 | FT | A | XE | Anchorage | N00 | 19K / L | 12.0 | | 95,069 | 4,013 | 0 | 63,067 | 162,149 | 162,149 |
| 021605 | Associate Attorney 2 | FT | A | XE | Fairbanks | N03 | 19B / C | 12.0 | | 78,679 | 3,321 | 0 | 56,396 | 138,396 | 138,396 |
| 021606 | Attorney 5 | FT | A | XE | Fairbanks | A03 | 25Q / R | 12.0 | | 205,708 | 8,305 | 0 | 106,209 | 320,222 | 320,222 |
| 021607 | Attorney 5 | FT | A | XE | Anchorage | A00 | 25Q | 12.0 | | 196,546 | 7,935 | 0 | 103,041 | 307,522 | 307,522 |
| 021608 | Attorney 5 | FT | A | XE | Juneau | A05 | 25J / K | 12.0 | | 164,333 | 6,936 | 0 | 91,257 | 262,526 | 262,526 |
| 021609 | Attorney 5 | FT | A | XE | Anchorage | A00 | 25Q | 12.0 | | 196,546 | 7,935 | 0 | 103,041 | 307,522 | 307,522 |
| 021610 | Attorney 4 | FT | A | XE | Palmer | A00 | 24L / M | 12.0 | | 156,846 | 6,620 | 0 | 88,210 | 251,676 | 251,676 |
| 021611 | Attorney 3 | FT | N | XE | Fairbanks | A03 | 22B / C | 12.0 | | 111,091 | 3,745 | 0 | 38,116 | 152,952 | 152,952 |
| 021612 | Attorney 4 | FT | A | XE | Anchorage | A00 | 24E / F | 12.0 | | 135,359 | 5,714 | 0 | 79,465 | 220,538 | 220,538 |
| 021613 | Paralegal 2 | FT | A | GP | Fairbanks | 203 | 16L / M | 12.0 | | 83,662 | 0 | 0 | 53,121 | 136,783 | 136,783 |
| 021614 | Attorney 5 | FT | A | XE | Fairbanks | A03 | 25M / N | 12.0 | | 176,234 | 7,115 | 0 | 96,019 | 279,368 | 279,368 |
| 021615 | Paralegal 2 | FT | A | GP | Anchorage | 200 | 16B / C | 12.0 | | 61,103 | 0 | 0 | 43,940 | 105,043 | 105,043 |
| 021620 | Accounting Technician 1 | FT | A | GP | Anchorage | 200 | 12B / C | 12.0 | | 46,686 | 0 | 0 | 38,072 | 84,758 | 8,476 |
| 021621 | Public Guardian 3 | FT | A | GP | Anchorage | 200 | 20R / S | 12.0 | | 127,172 | 0 | 25,135 | 81,060 | 233,367 | 168,484 |

Note: If a position is split, an asterisk (*) will appear in the Split/Count column. If the split position is also counted in the component, two asterisks (**) will appear in this column. [No valid job title] appearing in the Job Class Title indicates that the PCN has an invalid class code or invalid range for the class code effective date of this scenario.

Personal Services Expenditure Detail
Department of Administration

Scenario: FY2026 Governor (22363)
Component: Office of Public Advocacy (43)
RDU: Legal and Advocacy Services (11)

| PCN | Job Class Title | Time Status | Retire Code | Barg Unit | Location | Salary Sched | Range / Step | Comp Months | Split / Count | Annual Salaries | COLA | Premium Pay | Annual Benefits | Total Costs | UGF Amount |
|--------|--------------------------|-------------|-------------|-----------|-----------|--------------|--------------|-------------|---------------|-----------------|-------|-------------|-----------------|-------------|------------|
| 021622 | Paralegal Specialist 1 | FT | A | GP | Anchorage | 200 | 19C / D | 12.0 | | 77,618 | 0 | 0 | 50,661 | 128,279 | 128,279 |
| 021623 | Eligibility Technician 2 | FT | A | GP | Anchorage | 200 | 14E / F | 12.0 | | 59,236 | 0 | 445 | 43,361 | 103,042 | 74,393 |
| 021625 | Public Guardian 2 | FT | A | GP | Anchorage | 200 | 18B / C | 12.0 | | 71,011 | 0 | 531 | 48,188 | 119,730 | 86,442 |
| 021626 | Public Guardian 2 | FT | A | GP | Fairbanks | 203 | 18F / G | 12.0 | | 83,363 | 0 | 16,329 | 59,645 | 159,337 | 115,037 |
| 021627 | Public Guardian 2 | FT | A | GP | Juneau | 205 | 18B / C | 12.0 | | 74,658 | 0 | 14,519 | 55,366 | 144,543 | 104,356 |
| 021630 | Associate Attorney 2 | FT | A | XE | Anchorage | N00 | 19O / P | 12.0 | | 107,857 | 4,553 | 0 | 68,272 | 180,682 | 180,682 |
| 021631 | Paralegal 2 | FT | A | GP | Fairbanks | 203 | 16L / M | 12.0 | | 82,822 | 0 | 0 | 52,779 | 135,601 | 135,601 |
| 021632 | Accounting Technician 2 | FT | A | GP | Anchorage | 200 | 14B / C | 12.0 | | 52,478 | 0 | 0 | 40,429 | 92,907 | 92,907 |
| 021633 | Office Assistant 2 | FT | A | GP | Anchorage | 200 | 10C / D | 12.0 | | 42,701 | 0 | 0 | 36,450 | 79,151 | 79,151 |
| 021634 | Associate Attorney 2 | FT | A | XE | Anchorage | N00 | 19E / F | 12.0 | | 86,834 | 3,665 | 0 | 59,715 | 150,214 | 150,214 |
| 021635 | Public Guardian 3 | FT | A | GP | Anchorage | 200 | 20G / J | 12.0 | | 94,502 | 0 | 18,677 | 65,134 | 178,313 | 21,398 |
| 021637 | Associate Attorney 2 | FT | A | XE | Anchorage | N00 | 19J / K | 12.0 | | 91,598 | 3,866 | 0 | 61,654 | 157,118 | 157,118 |
| 021638 | Public Guardian 3 | FT | A | GP | Palmer | 200 | 20L / M | 12.0 | | 105,230 | 0 | 20,748 | 70,344 | 196,322 | 141,739 |
| 021639 | Attorney 3 | FT | A | XE | Anchorage | A00 | 22C | 12.0 | | 109,961 | 4,641 | 0 | 69,128 | 183,730 | 183,730 |
| 021640 | Public Guardian 3 | FT | A | GP | Anchorage | 200 | 20Q / R | 12.0 | | 123,731 | 0 | 24,343 | 79,337 | 227,411 | 164,184 |
| 021641 | Public Guardian 2 | FT | A | GP | Anchorage | 200 | 18F / G | 12.0 | | 80,495 | 0 | 609 | 52,080 | 133,184 | 96,155 |
| 021642 | Public Guardian 3 | FT | A | GP | Juneau | 205 | 20M | 12.0 | | 112,476 | 0 | 22,495 | 74,004 | 208,975 | 150,874 |
| 021643 | Accountant 4 | FT | A | SS | Anchorage | 200 | 20M / N | 12.0 | | 111,570 | 4,709 | 0 | 69,927 | 186,206 | 93,103 |
| 021644 | Associate Attorney 2 | FT | A | XE | Anchorage | N00 | 19J | 12.0 | | 89,661 | 3,785 | 0 | 60,866 | 154,312 | 154,312 |
| 021645 | Attorney 5 | FT | A | XE | Anchorage | A00 | 25F | 12.0 | | 149,955 | 6,330 | 0 | 85,406 | 241,691 | 241,691 |
| 021646 | Attorney 4 | FT | A | XE | Anchorage | A00 | 24D / E | 12.0 | | 134,041 | 5,658 | 0 | 78,929 | 218,628 | 218,628 |
| 021647 | Public Guardian 3 | FT | A | GP | Palmer | 200 | 20P / Q | 12.0 | | 119,840 | 0 | 23,579 | 77,442 | 220,861 | 159,455 |
| 021648 | Associate Attorney 2 | FT | A | XE | Anchorage | N00 | 19J / K | 12.0 | | 92,203 | 3,892 | 0 | 61,901 | 157,996 | 157,996 |
| 021649 | Attorney 6 | FT | A | XE | Anchorage | A00 | 26Q / R | 12.0 | | 205,520 | 8,297 | 0 | 106,144 | 319,961 | 319,961 |
| 021650 | Attorney 5 | FT | A | XE | Juneau | A05 | 25L / M | 12.0 | | 178,697 | 7,214 | 0 | 96,871 | 282,782 | 282,782 |
| 021651 | Attorney 4 | FT | A | XE | Bethel | A50 | 24E / F | 12.0 | | 204,864 | 8,271 | 0 | 105,917 | 319,052 | 319,052 |
| 021652 | Associate Attorney 2 | FT | A | XE | Anchorage | N00 | 19F | 12.0 | | 86,834 | 3,665 | 0 | 59,715 | 150,214 | 150,214 |
| 021653 | Associate Attorney 2 | FT | A | XE | Anchorage | N00 | 19D / E | 12.0 | | 83,249 | 3,514 | 0 | 58,256 | 145,019 | 145,019 |
| 021654 | Attorney 4 | FT | A | XE | Fairbanks | A03 | 24N | 12.0 | | 168,656 | 7,119 | 0 | 93,017 | 268,792 | 268,792 |
| 021655 | Public Guardian 3 | FT | A | GP | Anchorage | 200 | 20S | 12.0 | | 129,753 | 0 | 25,950 | 82,442 | 238,145 | 171,934 |
| 021656 | Attorney 4 | FT | A | XE | Anchorage | A00 | 24C | 12.0 | | 125,892 | 5,314 | 0 | 75,612 | 206,818 | 206,818 |
| 021657 | Associate Attorney 2 | FT | A | XE | Anchorage | N00 | 19J / K | 12.0 | | 92,324 | 3,897 | 0 | 61,950 | 158,171 | 158,171 |
| 021658 | Associate Attorney 2 | FT | A | XE | Anchorage | N00 | 19C | 12.0 | | 78,254 | 3,303 | 0 | 56,223 | 137,780 | 137,780 |
| 021659 | Paralegal 2 | FT | A | GP | Anchorage | 200 | 16Q | 12.0 | | 93,171 | 0 | 0 | 56,991 | 150,162 | 150,162 |
| 021660 | Public Guardian 4 | FT | A | SS | Anchorage | 200 | 22U | 12.0 | | 159,806 | 7,661 | 29,963 | 100,842 | 298,272 | 215,343 |
| 021661 | Attorney 4 | FT | A | XE | Anchorage | A00 | 24M / N | 12.0 | | 160,953 | 6,794 | 0 | 89,882 | 257,629 | 257,629 |
| 021664 | Attorney 4 | FT | A | XE | Anchorage | A00 | 24J | 12.0 | | 144,086 | 6,082 | 0 | 83,017 | 233,185 | 233,185 |
| 021665 | Associate Attorney 2 | FT | A | XE | Anchorage | N00 | 19E / F | 12.0 | | 84,754 | 3,577 | 0 | 58,869 | 147,200 | 147,200 |

Note: If a position is split, an asterisk (*) will appear in the Split/Count column. If the split position is also counted in the component, two asterisks (**) will appear in this column. [No valid job title] appearing in the Job Class Title indicates that the PCN has an invalid class code or invalid range for the class code effective date of this scenario.

Personal Services Expenditure Detail
Department of Administration

Scenario: FY2026 Governor (22363)
Component: Office of Public Advocacy (43)
RDU: Legal and Advocacy Services (11)

| PCN | Job Class Title | Time Status | Retire Code | Barg Unit | Location | Salary Sched | Range / Step | Comp Months | Split / Count | Annual Salaries | COLA | Premium Pay | Annual Benefits | Total Costs | UGF Amount |
|--------|----------------------------|-------------|-------------|-----------|-----------|--------------|--------------|-------------|---------------|-----------------|--------|-------------|-----------------|-------------|------------|
| 021666 | Paralegal 1 | FT | A | GP | Kenai | 200 | 14B / C | 12.0 | | 52,286 | 0 | 0 | 40,351 | 92,637 | 92,637 |
| 021667 | Associate Attorney 2 | FT | A | XE | Fairbanks | N03 | 19E / F | 12.0 | | 87,566 | 3,696 | 0 | 60,013 | 151,275 | 151,275 |
| 021668 | Public Guardian 2 | FT | A | GP | Anchorage | 200 | 18F / G | 12.0 | | 80,495 | 0 | 15,853 | 58,284 | 154,632 | 111,640 |
| 021669 | Paralegal Specialist 1 | FT | A | SS | Anchorage | 200 | 19M | 12.0 | | 101,400 | 4,373 | 2,193 | 66,680 | 174,646 | 174,646 |
| 021670 | Administrative Assistant 1 | FT | A | GP | Anchorage | 200 | 12B / C | 12.0 | | 46,775 | 0 | 0 | 38,108 | 84,883 | 84,883 |
| 021671 | Attorney 5 | FT | A | XE | Palmer | A00 | 25K / L | 12.0 | | 160,509 | 6,775 | 0 | 89,701 | 256,985 | 256,985 |
| 021672 | Attorney 4 | FT | A | XE | Anchorage | A00 | 24C / D | 12.0 | | 127,795 | 5,394 | 0 | 76,386 | 209,575 | 209,575 |
| 021673 | Paralegal 2 | FT | A | GP | Palmer | 200 | 16J / K | 12.0 | | 76,404 | 0 | 0 | 50,167 | 126,571 | 126,571 |
| 021674 | Accounting Technician 3 | FT | A | GP | Anchorage | 200 | 16O | 12.0 | | 87,399 | 0 | 0 | 54,642 | 142,041 | 14,204 |
| 021676 | Public Guardian 2 | FT | A | GP | Anchorage | 200 | 18C / D | 12.0 | | 72,991 | 0 | 14,305 | 54,600 | 141,896 | 102,445 |
| 021677 | Paralegal 3 | FT | A | GP | Anchorage | 200 | 17E | 12.0 | | 71,526 | 0 | 0 | 48,182 | 119,708 | 0 |
| 021678 | Paralegal 1 | FT | A | GP | Bethel | 250 | 14L | 12.0 | | 103,428 | 0 | 0 | 61,166 | 164,594 | 164,594 |
| 021679 | Attorney 5 | FT | A | XE | Bethel | A50 | 25P | 12.0 | | 281,366 | 11,359 | 0 | 132,364 | 425,089 | 425,089 |
| 021680 | Attorney 5 | FT | A | XE | Palmer | A00 | 25K / L | 12.0 | | 162,282 | 6,850 | 0 | 90,423 | 259,555 | 259,555 |
| 021681 | Attorney 5 | FT | A | XE | Anchorage | A00 | 25P / Q | 12.0 | | 191,219 | 7,720 | 0 | 101,200 | 300,139 | 300,139 |
| 021682 | Attorney 2 | FT | A | XE | Anchorage | A00 | 20C / D | 12.0 | | 99,200 | 4,187 | 0 | 64,748 | 168,135 | 168,135 |
| 021683 | Public Guardian 2 | FT | A | GP | Anchorage | 200 | 18K | 12.0 | | 87,906 | 0 | 17,581 | 62,004 | 167,491 | 120,924 |
| 021684 | Attorney 5 | FT | A | XE | Anchorage | A00 | 25M / N | 12.0 | | 172,441 | 7,112 | 0 | 94,557 | 274,110 | 274,110 |
| 021686 | Attorney 4 | FT | A | XE | Anchorage | A00 | 24C | 12.0 | | 125,892 | 5,314 | 0 | 75,612 | 206,818 | 206,818 |
| 021687 | Investigator 3 | FT | A | GP | Palmer | 200 | 18B / C | 12.0 | | 69,365 | 0 | 0 | 47,302 | 116,667 | 116,667 |
| 021688 | Attorney 4 | FT | A | XE | Palmer | A00 | 24J | 12.0 | | 144,086 | 6,082 | 0 | 83,017 | 233,185 | 233,185 |
| 021689 | Administrative Officer 1 | FT | A | SS | Anchorage | 200 | 17C / D | 12.0 | | 73,354 | 3,096 | 0 | 54,373 | 130,823 | 130,823 |
| 021690 | Accounting Technician 3 | FT | A | GP | Anchorage | 200 | 16C / D | 12.0 | | 63,453 | 0 | 0 | 44,896 | 108,349 | 108,349 |
| 021691 | Law Office Assistant 1 | FT | A | GP | Anchorage | 200 | 11D / E | 12.0 | | 47,015 | 0 | 0 | 38,206 | 85,221 | 85,221 |
| 021693 | Attorney 4 | FT | A | XE | Anchorage | A00 | 24E / F | 12.0 | | 139,048 | 5,869 | 0 | 80,966 | 225,883 | 225,883 |
| 021694 | Attorney 4 | FT | A | XE | Anchorage | A00 | 24E | 12.0 | | 134,979 | 5,697 | 0 | 79,310 | 219,986 | 219,986 |
| 021695 | Attorney 5 | FT | A | XE | Anchorage | A00 | 25M / N | 12.0 | | 171,287 | 7,137 | 0 | 94,088 | 272,512 | 272,512 |
| 021696 | Attorney 4 | FT | A | XE | Anchorage | A00 | 24E / F | 12.0 | | 135,549 | 5,722 | 0 | 79,542 | 220,813 | 220,813 |
| 021697 | Attorney 5 | FT | A | XE | Fairbanks | A03 | 25J | 12.0 | | 159,471 | 6,731 | 0 | 89,279 | 255,481 | 255,481 |
| 021698 | Attorney 4 | FT | A | XE | Fairbanks | A03 | 24K | 12.0 | | 153,231 | 6,468 | 0 | 86,739 | 246,438 | 246,438 |
| 021699 | Paralegal 2 | FT | A | GP | Fairbanks | 203 | 16N | 12.0 | | 87,185 | 0 | 0 | 54,555 | 141,740 | 141,740 |
| 021700 | Associate Attorney 2 | FT | A | XE | Palmer | N00 | 19J | 12.0 | | 89,661 | 3,785 | 0 | 60,866 | 154,312 | 154,312 |
| 021701 | Associate Attorney 2 | FT | A | XE | Juneau | N05 | 19L / M | 12.0 | | 101,541 | 4,286 | 0 | 65,701 | 171,528 | 171,528 |
| 021702 | Paralegal 2 | FT | A | GP | Anchorage | 200 | 16C / D | 12.0 | | 62,186 | 0 | 0 | 44,380 | 106,566 | 106,566 |
| 021703 | Paralegal 1 | FT | A | GP | Anchorage | 100 | 14A | 12.0 | | 50,934 | 0 | 0 | 39,801 | 90,735 | 90,735 |
| 021704 | Law Office Assistant 2 | FT | A | GP | Anchorage | 200 | 13A / B | 12.0 | | 48,738 | 0 | 0 | 38,907 | 87,645 | 87,645 |
| 021705 | Public Guardian 2 | FT | A | GP | Anchorage | 200 | 18C | 12.0 | | 71,526 | 0 | 14,305 | 54,004 | 139,835 | 100,957 |
| 021706 | Office Assistant 2 | FT | A | GP | Anchorage | 200 | 10B / C | 12.0 | | 41,004 | 0 | 0 | 35,759 | 76,763 | 0 |

Note: If a position is split, an asterisk (*) will appear in the Split/Count column. If the split position is also counted in the component, two asterisks (**) will appear in this column. [No valid job title] appearing in the Job Class Title indicates that the PCN has an invalid class code or invalid range for the class code effective date of this scenario.

Personal Services Expenditure Detail
Department of Administration

Scenario: FY2026 Governor (22363)
Component: Office of Public Advocacy (43)
RDU: Legal and Advocacy Services (11)

| PCN | Job Class Title | Time Status | Retire Code | Barg Unit | Location | Salary Sched | Range / Step | Comp Months | Split / Count | Annual Salaries | COLA | Premium Pay | Annual Benefits | Total Costs | UGF Amount |
|--------|------------------------|-------------|-------------|-----------|-----------|--------------|--------------|-------------|---------------|-----------------|--------|-------------|-----------------|-------------|------------|
| 021707 | Associate Attorney 2 | FT | A | XE | Palmer | N00 | 19D / E | 12.0 | | 83,501 | 3,525 | 0 | 58,359 | 145,385 | 145,385 |
| 021708 | Law Office Assistant 2 | FT | A | GP | Fairbanks | 203 | 13C | 12.0 | | 51,987 | 0 | 0 | 40,229 | 92,216 | 92,216 |
| 021709 | Investigator 2 | FT | A | GP | Anchorage | 200 | 16B / C | 12.0 | | 61,200 | 0 | 0 | 43,979 | 105,179 | 105,179 |
| 021710 | Public Guardian 2 | FT | A | GP | Anchorage | 200 | 18F / G | 12.0 | | 81,576 | 0 | 15,853 | 58,724 | 156,153 | 112,738 |
| 021711 | Law Office Assistant 2 | FT | A | GP | Anchorage | 200 | 13E / F | 12.0 | | 55,545 | 0 | 0 | 41,677 | 97,222 | 97,222 |
| 021712 | Attorney 5 | FT | A | XE | Anchorage | A00 | 25K / L | 12.0 | | 162,627 | 6,864 | 0 | 90,563 | 260,054 | 260,054 |
| 021713 | Attorney 3 | FT | A | XE | Anchorage | A00 | 22F | 12.0 | | 121,836 | 5,143 | 0 | 73,961 | 200,940 | 200,940 |
| 021714 | Attorney 4 | FT | A | XE | Fairbanks | A03 | 24C / D | 12.0 | | 133,876 | 5,651 | 0 | 78,861 | 218,388 | 218,388 |
| 021715 | Law Office Assistant 2 | FT | A | GP | Palmer | 200 | 13J | 12.0 | | 60,372 | 0 | 0 | 43,642 | 104,014 | 104,014 |
| 021716 | Attorney 4 | FT | A | XE | Anchorage | A00 | 24N / O | 12.0 | | 163,963 | 6,921 | 0 | 91,107 | 261,991 | 261,991 |
| 021717 | Attorney 4 | FT | A | XE | Anchorage | A00 | 24M / N | 12.0 | | 159,452 | 6,730 | 0 | 89,271 | 255,453 | 255,453 |
| 021718 | Paralegal 2 | FT | A | GP | Palmer | 200 | 16M / N | 12.0 | | 83,136 | 0 | 0 | 52,907 | 136,043 | 136,043 |
| 021719 | Attorney 6 | FT | A | XE | Anchorage | A00 | 26M / N | 12.0 | | 177,250 | 7,156 | 0 | 96,371 | 280,777 | 280,777 |
| 021720 | Attorney 4 | FT | A | XE | Anchorage | A00 | 24J / K | 12.0 | | 147,401 | 6,222 | 0 | 84,366 | 237,989 | 237,989 |
| 021721 | Attorney 4 | FT | A | XE | Anchorage | A00 | 24D / E | 12.0 | | 131,877 | 5,567 | 0 | 78,048 | 215,492 | 215,492 |
| 021722 | Paralegal 2 | FT | A | GP | Anchorage | 200 | 16B / C | 12.0 | | 60,991 | 0 | 0 | 43,894 | 104,885 | 104,885 |
| 021723 | Law Office Assistant 2 | FT | A | GP | Juneau | 105 | 13C | 12.0 | | 53,489 | 0 | 0 | 40,841 | 94,330 | 94,330 |
| 021724 | Paralegal 1 | FT | A | GP | Juneau | 205 | 14B / C | 12.0 | | 55,150 | 0 | 0 | 41,517 | 96,667 | 96,667 |
| 021725 | Investigator 3 | FT | A | GP | Anchorage | 200 | 18A / B | 12.0 | | 69,088 | 0 | 0 | 47,189 | 116,277 | 26,744 |
| 021726 | Public Guardian 3 | FT | A | GP | Anchorage | 200 | 20L | 12.0 | | 103,740 | 0 | 20,748 | 69,737 | 194,225 | 140,225 |
| 021727 | Public Guardian 2 | FT | A | GP | Anchorage | 200 | 18C / D | 12.0 | | 72,620 | 0 | 550 | 48,851 | 122,021 | 88,096 |
| 021728 | Attorney 4 | FT | A | XE | Anchorage | A00 | 24R / S | 12.0 | | 190,743 | 7,700 | 0 | 101,035 | 299,478 | 299,478 |
| 021729 | Public Guardian 2 | FT | A | GP | Anchorage | 200 | 18A / B | 12.0 | | 68,832 | 0 | 513 | 47,294 | 116,639 | 12,830 |
| 021730 | Attorney 4 | FT | A | XE | Anchorage | A00 | 24M | 12.0 | | 158,594 | 6,694 | 0 | 88,922 | 254,210 | 254,210 |
| 021731 | Law Office Assistant 2 | FT | A | GP | Anchorage | 200 | 13J | 12.0 | | 60,372 | 0 | 0 | 43,642 | 104,014 | 104,014 |
| 021733 | Project Assistant | PT | A | GP | Palmer | 200 | 16C / D | 12.0 | | 47,405 | 0 | 0 | 28,829 | 76,234 | 76,234 |
| 021734 | Project Assistant | PT | A | GP | Fairbanks | 203 | 16C | 12.0 | | 31,469 | 0 | 0 | 22,343 | 53,812 | 53,812 |
| 021735 | Paralegal 3 | FT | A | GP | Anchorage | 200 | 17A / B | 12.0 | | 63,999 | 0 | 0 | 45,118 | 109,117 | 109,117 |
| 021736 | Attorney 5 | FT | A | XE | Kenai | A00 | 25R | 12.0 | | 378,066 | 15,263 | 0 | 165,793 | 559,122 | 559,122 |
| 021737 | Associate Attorney 2 | FT | A | XE | Palmer | N00 | 19K | 12.0 | | 92,567 | 3,907 | 0 | 62,049 | 158,523 | 158,523 |
| 021738 | Attorney 4 | FT | A | XE | Anchorage | A00 | 24K / L | 12.0 | | 149,975 | 6,330 | 0 | 85,414 | 241,719 | 241,719 |
| 021739 | Attorney 4 | FT | A | XE | Palmer | A00 | 24K | 12.0 | | 148,766 | 6,279 | 0 | 84,922 | 239,967 | 239,967 |
| 021740 | Attorney 4 | FT | A | XE | Anchorage | A00 | 24E / F | 12.0 | | 137,793 | 5,816 | 0 | 80,456 | 224,065 | 0 |
| 021741 | Attorney 4 | FT | A | XE | Anchorage | A00 | 24E / F | 12.0 | | 137,337 | 5,797 | 0 | 80,270 | 223,404 | 223,404 |
| 021742 | Public Guardian 2 | FT | A | GP | Fairbanks | 203 | 18B / C | 12.0 | | 72,770 | 0 | 14,242 | 54,485 | 141,497 | 102,157 |
| 021743 | Public Guardian 2 | FT | A | GP | Palmer | 200 | 18L | 12.0 | | 90,773 | 0 | 18,154 | 63,404 | 172,331 | 124,418 |
| 021744 | Public Guardian 2 | FT | A | GP | Anchorage | 200 | 18C | 12.0 | | 71,526 | 0 | 550 | 48,406 | 120,482 | 86,984 |
| 021745 | Attorney 3 | FT | A | XE | Anchorage | A00 | 22F | 12.0 | | 121,836 | 5,143 | 0 | 73,961 | 200,940 | 200,940 |

Note: If a position is split, an asterisk (*) will appear in the Split/Count column. If the split position is also counted in the component, two asterisks (**) will appear in this column. [No valid job title] appearing in the Job Class Title indicates that the PCN has an invalid class code or invalid range for the class code effective date of this scenario.

Personal Services Expenditure Detail
Department of Administration

Scenario: FY2026 Governor (22363)
Component: Office of Public Advocacy (43)
RDU: Legal and Advocacy Services (11)

| PCN | Job Class Title | Time Status | Retire Code | Barg Unit | Location | Salary Sched | Range / Step | Comp Months | Split / Count | Annual Salaries | COLA | Premium Pay | Annual Benefits | Total Costs | UGF Amount |
|----------|--------------------------|-------------|-------------|-----------|-----------|--------------|--------------|-------------|---------------|-----------------|-------|-------------|-----------------|-------------|------------|
| 021746 | Eligibility Technician 2 | FT | A | GP | Anchorage | 200 | 14Q | 12.0 | | 80,945 | 0 | 622 | 52,268 | 133,835 | 96,625 |
| 021747 | Public Guardian 2 | FT | A | GP | Anchorage | 200 | 18N / O | 12.0 | | 98,983 | 0 | 19,351 | 67,233 | 185,567 | 133,974 |
| 021748 | Law Office Assistant 3 | FT | A | SS | Anchorage | 600 | 14J / K | 12.0 | | 65,313 | 2,757 | 0 | 51,100 | 119,170 | 0 |
| 021749 | Associate Attorney 2 | FT | A | XE | Fairbanks | N03 | 19D / E | 12.0 | | 84,431 | 3,564 | 0 | 58,737 | 146,732 | 146,732 |
| 021750 | Associate Attorney 2 | FT | A | XE | Palmer | N00 | 19L / M | 12.0 | | 98,282 | 4,148 | 0 | 64,375 | 166,805 | 166,805 |
| 021751 | Associate Attorney 2 | FT | A | XE | Juneau | N05 | 19D / E | 12.0 | | 85,956 | 3,628 | 0 | 59,358 | 148,942 | 148,942 |
| 021752 | Associate Attorney 2 | FT | A | XE | Anchorage | N00 | 19J / K | 12.0 | | 92,203 | 3,892 | 0 | 61,901 | 157,996 | 157,996 |
| 021753 | Attorney 4 | FT | A | XE | Anchorage | A00 | 24J | 12.0 | | 144,086 | 6,082 | 0 | 83,017 | 233,185 | 0 |
| 021754 | Attorney 4 | FT | N | XE | Fairbanks | A03 | 24C | 12.0 | | 129,675 | 4,371 | 0 | 40,415 | 174,461 | 174,461 |
| 021755 | Attorney 4 | FT | A | XE | Anchorage | A00 | 24K | 12.0 | | 148,766 | 6,279 | 0 | 84,922 | 239,967 | 239,967 |
| 021756 | Attorney 3 | FT | A | XE | Juneau | A05 | 22E / F | 12.0 | | 124,835 | 5,269 | 0 | 75,182 | 205,286 | 205,286 |
| 021757 | Attorney 2 | FT | A | XE | Kenai | A00 | 20D / E | 12.0 | | 101,931 | 4,303 | 0 | 65,860 | 172,094 | 172,094 |
| 021758 | Law Office Assistant 2 | FT | A | GP | Anchorage | 200 | 13E / F | 12.0 | | 54,514 | 0 | 0 | 41,258 | 95,772 | 95,772 |
| 021759 | Law Office Assistant 2 | FT | A | GP | Anchorage | 200 | 13D / E | 12.0 | | 53,114 | 0 | 0 | 40,688 | 93,802 | 0 |
| 021760 | Attorney 3 | FT | A | XE | Anchorage | A00 | 22E / F | 12.0 | | 120,608 | 5,091 | 0 | 73,461 | 199,160 | 199,160 |
| 021761 | Attorney 5 | FT | A | XE | Anchorage | A00 | 25J / K | 12.0 | | 157,136 | 6,633 | 0 | 88,328 | 252,097 | 252,097 |
| 021762 | Paralegal 2 | FT | A | GP | Anchorage | 200 | 16B / C | 12.0 | | 61,940 | 0 | 0 | 44,280 | 106,220 | 106,220 |
| 021763 | Attorney 4 | FT | A | XE | Anchorage | A00 | 24F / J | 12.0 | | 142,457 | 6,013 | 0 | 82,354 | 230,824 | 230,824 |
| 021764 | Investigator 3 | FT | A | GP | Anchorage | 200 | 18M | 12.0 | | 93,717 | 0 | 0 | 57,213 | 150,930 | 150,930 |
| 021765 | Attorney 4 | FT | A | XE | Anchorage | A00 | 24K / L | 12.0 | | 150,982 | 6,373 | 0 | 85,824 | 243,179 | 243,179 |
| 021766 | Law Office Assistant 2 | FT | A | GP | Palmer | 200 | 13C | 12.0 | | 50,466 | 0 | 0 | 39,610 | 90,076 | 90,076 |
| 021767 | Public Guardian 2 | FT | A | GP | Anchorage | 200 | 18C | 12.0 | | 71,526 | 0 | 14,305 | 54,004 | 139,835 | 100,957 |
| 021768 | Attorney 5 | FT | A | XE | Anchorage | A00 | 25K / L | 12.0 | | 161,331 | 6,810 | 0 | 90,036 | 258,177 | 258,177 |
| 021769 | Attorney 4 | FT | A | XE | Anchorage | A00 | 24M / N | 12.0 | | 160,052 | 6,756 | 0 | 89,515 | 256,323 | 256,323 |
| 021770 | Attorney 4 | FT | A | XE | Anchorage | A00 | 24L | 12.0 | | 153,602 | 6,484 | 0 | 86,890 | 246,976 | 246,976 |
| 021771 | Paralegal 2 | FT | A | GP | Anchorage | 200 | 16C / D | 12.0 | | 63,102 | 0 | 1,432 | 45,336 | 109,870 | 109,870 |
| 021772 | Project Assistant | FT | A | GP | Anchorage | 200 | 16B / C | 12.0 | | 60,685 | 0 | 0 | 43,769 | 104,454 | 104,454 |
| 021773 | Attorney 4 | FT | A | XE | Bethel | A50 | 24J | 12.0 | | 216,138 | 8,726 | 0 | 109,814 | 334,678 | 334,678 |
| 021783 | Law Office Assistant 2 | FT | A | GP | Palmer | 200 | 13C / D | 12.0 | | 51,839 | 0 | 388 | 40,327 | 92,554 | 92,554 |
| 021784 | Law Office Assistant 2 | FT | A | GP | Fairbanks | 203 | 13C / D | 12.0 | | 52,835 | 0 | 0 | 40,575 | 93,410 | 93,410 |
| 021785 | Law Office Assistant 2 | FT | A | GP | Palmer | 200 | 13D / E | 12.0 | | 52,670 | 0 | 0 | 40,507 | 93,177 | 93,177 |
| 021787 | Investigator 3 | FT | A | GP | Fairbanks | 203 | 18C / D | 12.0 | | 74,437 | 0 | 0 | 49,367 | 123,804 | 123,804 |
| 021788 | Investigator 3 | FT | A | GP | Juneau | 205 | 18C | 12.0 | | 75,095 | 0 | 0 | 49,634 | 124,729 | 124,729 |
| 021789 | Attorney 5 | FT | A | XE | Anchorage | A00 | 25N | 12.0 | | 175,949 | 7,103 | 0 | 95,921 | 278,973 | 278,973 |
| 024119 | Attorney 2 | FT | A | XE | Anchorage | A00 | 20D / E | 12.0 | | 100,999 | 4,263 | 0 | 65,481 | 170,743 | 170,743 |
| 02N07051 | Office Assistant 1 | NP | N | GP | Anchorage | 200 | 8A / A | 12.0 | | 123,786 | 0 | 0 | 12,453 | 136,239 | 136,239 |
| 02N07052 | Law Office Assistant 1 | NP | N | GP | Anchorage | 200 | 11A / A | 12.0 | | 116,100 | 0 | 0 | 11,680 | 127,780 | 127,780 |
| 02N13014 | Paralegal 1 | NP | N | GP | Anchorage | 200 | 14C / C | 12.0 | | 59,767 | 0 | 1,245 | 6,138 | 67,150 | 67,150 |

Note: If a position is split, an asterisk (*) will appear in the Split/Count column. If the split position is also counted in the component, two asterisks (**) will appear in this column. [No valid job title] appearing in the Job Class Title indicates that the PCN has an invalid class code or invalid range for the class code effective date of this scenario.

Personal Services Expenditure Detail
Department of Administration

Scenario: FY2026 Governor (22363)
Component: Office of Public Advocacy (43)
RDU: Legal and Advocacy Services (11)

| PCN | Job Class Title | Time Status | Retire Code | Barg Unit | Location | Salary Sched | Range / Step | Comp Months | Split / Count | Annual Salaries | COLA | Premium Pay | Annual Benefits | Total Costs | UGF Amount |
|--|------------------------|-------------|-------------|-----------|-----------|--------------|--------------|-------------|---------------|-----------------|-------|-------------|---|-------------|------------|
| 02N15020 | Law Office Assistant 1 | NP | N | GP | Juneau | 205 | 11A / A | 12.0 | | 44,031 | 0 | 0 | 4,430 | 48,461 | 48,461 |
| 02N19012 | Program Coordinator 1 | NP | N | GP | Anchorage | 200 | 18A / A | 12.0 | | 66,788 | 0 | 0 | 27,332 | 94,120 | 94,120 |
| 02N19041 | Law Office Assistant 1 | NP | N | GP | Fairbanks | 203 | 11A / A | 12.0 | | 43,193 | 0 | 0 | 4,345 | 47,538 | 47,538 |
| 02N20006 | Office Assistant 1 | NP | N | GP | Kenai | 200 | 8A / A | 12.0 | | 34,983 | 0 | 0 | 3,519 | 38,502 | 38,502 |
| 02N20019 | Investigator 2 | NP | N | GP | Fairbanks | 203 | 16A / A | 12.0 | | 59,709 | 0 | 0 | 26,457 | 86,166 | 86,166 |
| 02N21014 | Project Assistant | NP | N | GP | Juneau | 205 | 16A / A | 12.0 | | 60,879 | 0 | 0 | 26,601 | 87,480 | 87,480 |
| 02N21015 | Office Assistant 1 | NP | N | GP | Bethel | 250 | 8A / A | 12.0 | | 4,844 | 0 | 0 | 487 | 5,331 | 5,331 |
| 02TPX003 | Attorney 1 | NP | N | XE | Anchorage | A00 | 18A / A | 12.0 | | 78,819 | 2,602 | 0 | 7,929 | 89,350 | 89,350 |
| 02TPX006 | Attorney 2 | NP | N | XE | Palmer | A00 | 20C | 12.0 | | 88,938 | 2,937 | 0 | 8,947 | 100,822 | 100,822 |
| Total | | | | | | | | | | | | | Total Salary Costs: | 20,487,334 | |
| Positions | | | | | | | | | | | | | Total COLA: | 560,192 | |
| Full Time Positions: | | | | | | | | | | | | | Total Premium Pay: | 511,922 | |
| Part Time Positions: | | | | | | | | | | | | | Total Benefits: | 12,321,162 | |
| Non Permanent Positions: | | | | | | | | | | | | | Total Pre-Vacancy: | 33,880,610 | |
| Positions in Component: | | | | | | | | | | | | | Minus Vacancy Adjustment of 7.00%: | (2,372,910) | |
| Total Component Months: 2,388.0 | | | | | | | | | | | | | Total Post-Vacancy: | 31,507,700 | |
| | | | | | | | | | | | | | Plus Lump Sum Premium Pay: | 0 | |
| | | | | | | | | | | | | | Personal Services Line 100: | 31,507,700 | |

| PCN Funding Sources: | Pre-Vacancy | Post-Vacancy | Percent |
|--|-------------------|-------------------|----------------|
| 1004 Unrestricted General Fund Receipts | 28,447,645 | 26,455,246 | 83.96% |
| 1005 General Fund/Program Receipts | 2,199,490 | 2,045,444 | 6.49% |
| 1007 Interagency Receipts | 505,900 | 470,468 | 1.49% |
| 1037 General Fund / Mental Health | 2,479,681 | 2,306,011 | 7.32% |
| 1092 Mental Health Trust Authority Authorized Receipts | 247,894 | 230,532 | 0.73% |
| Total PCN Funding: | 33,880,610 | 31,507,700 | 100.00% |

Note: If a position is split, an asterisk (*) will appear in the Split/Count column. If the split position is also counted in the component, two asterisks (**) will appear in this column. [No valid job title] appearing in the Job Class Title indicates that the PCN has an invalid class code or invalid range for the class code effective date of this scenario.

Department of Administration
 Office of Public Advocacy (43)
 Legal and Advocacy Services (11)
 FY2026 Governor's Budget
 Position Totals: 182 PFT | 2 PPT | 12 NP
Public Guardian Section - APG

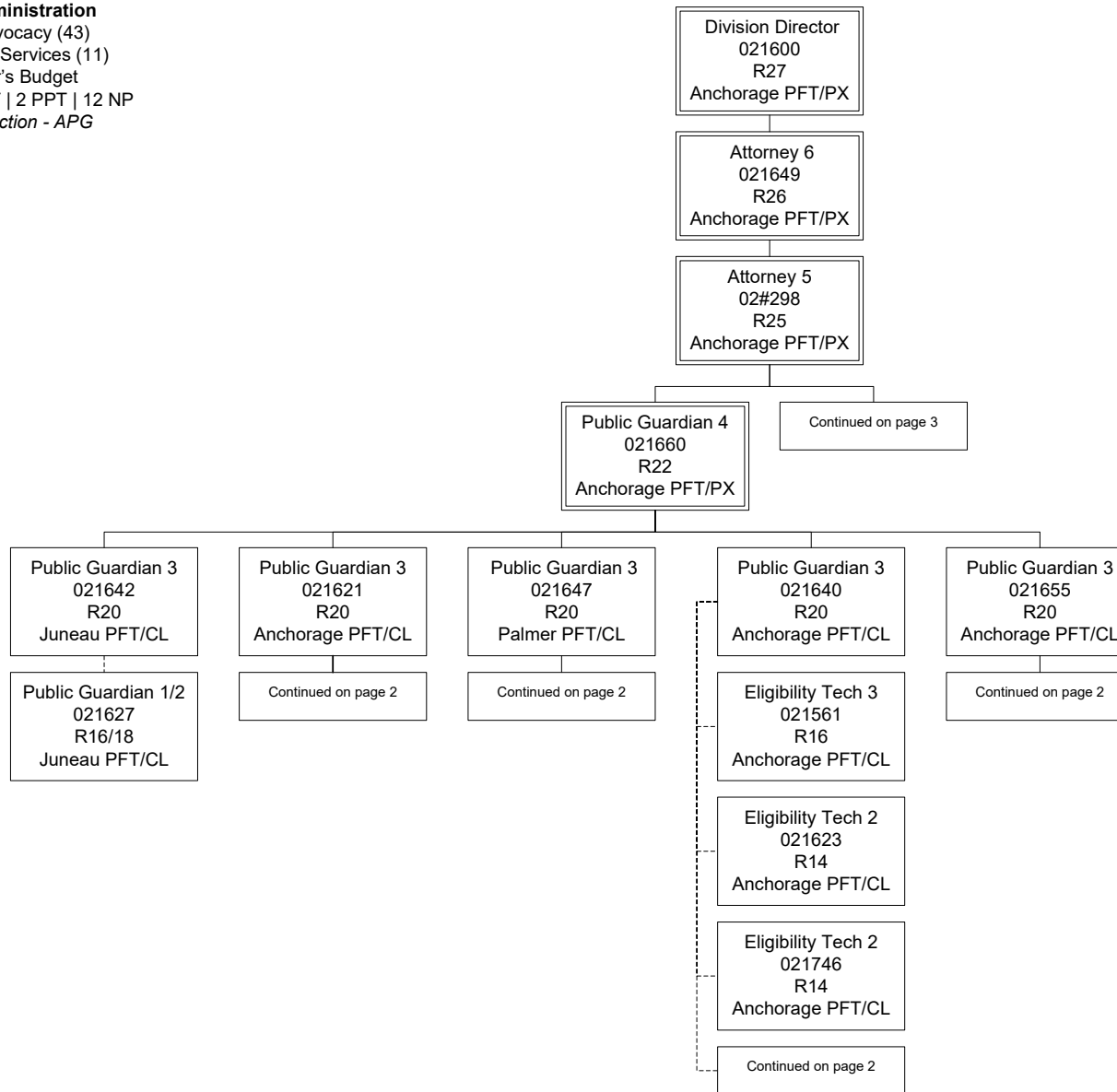

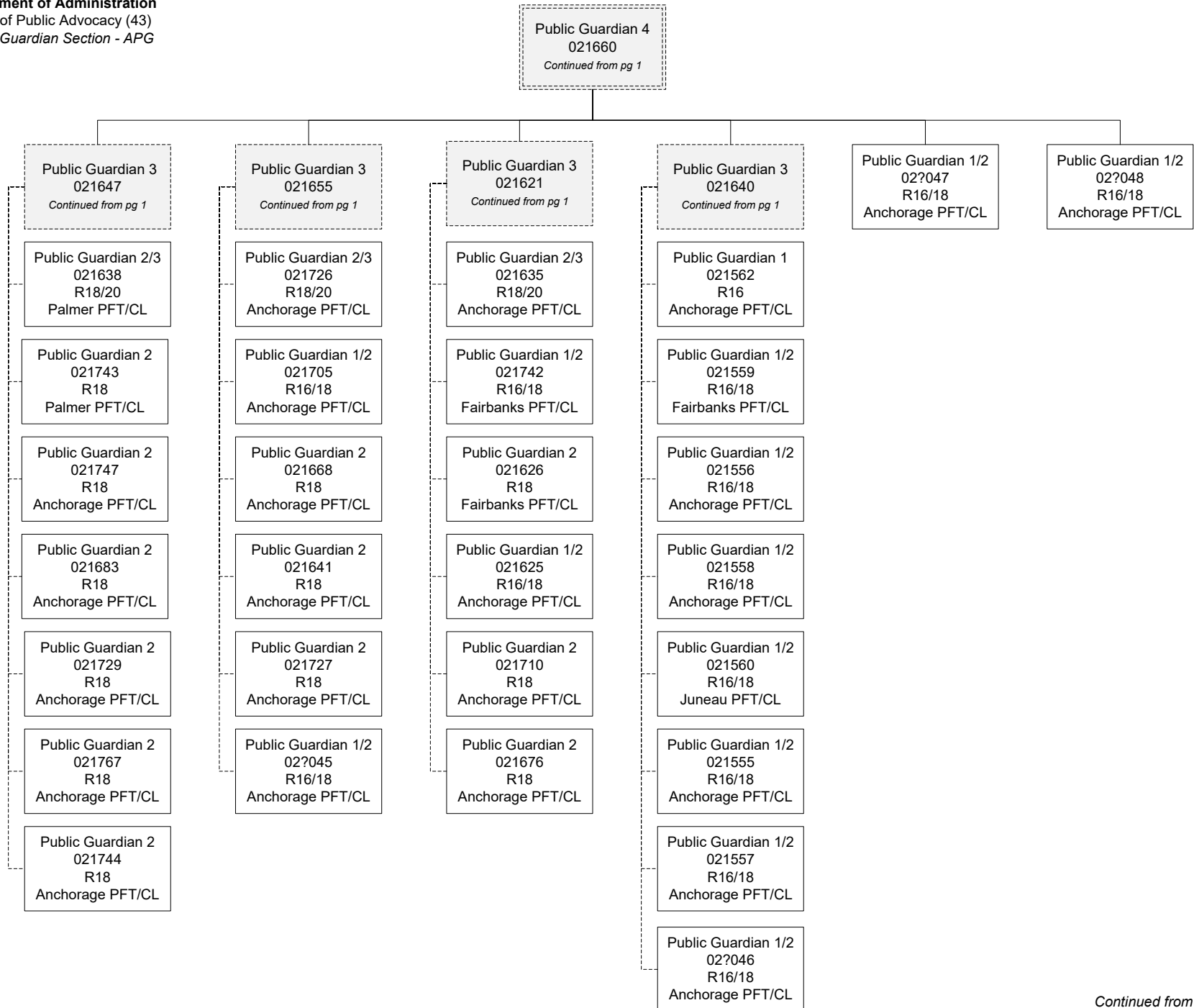

Department of Administration
Office of Public Advocacy (43)
Public Guardian Section - APG

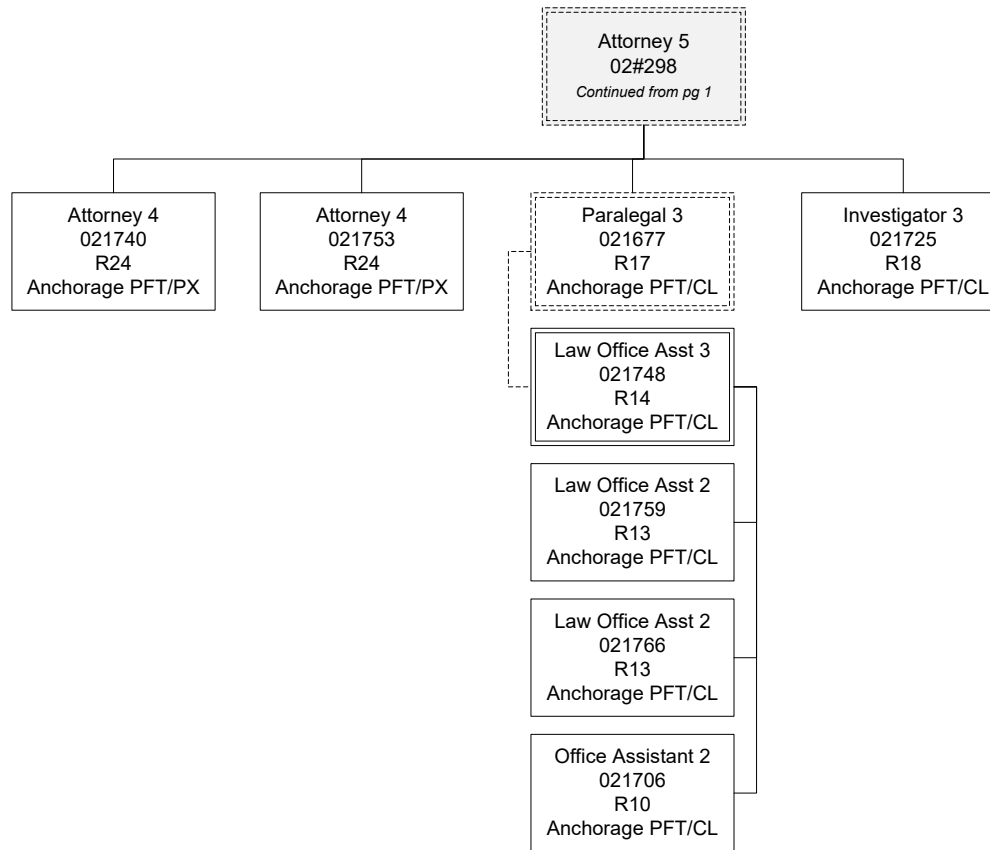

Department of Administration
Office of Public Advocacy (43)
Juneau Civil & Criminal

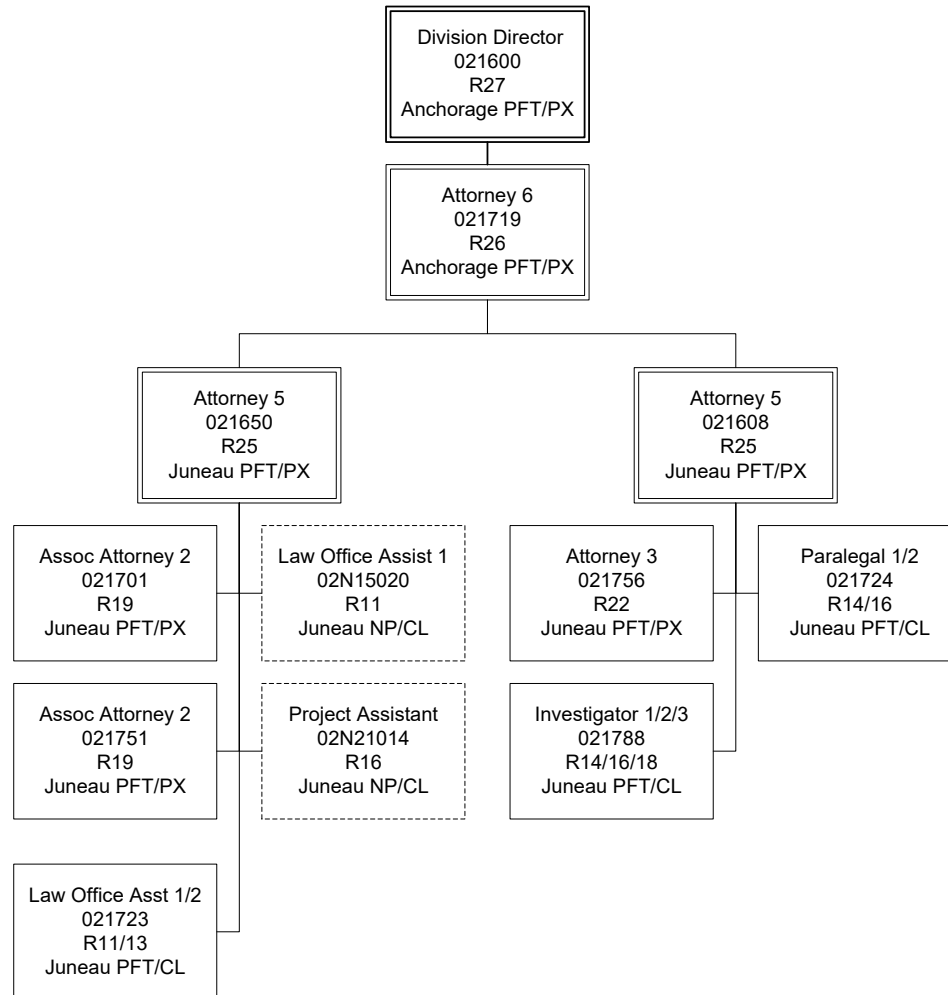

Department of Administration
Office of Public Advocacy (43)
Anchorage Conflict Counsel

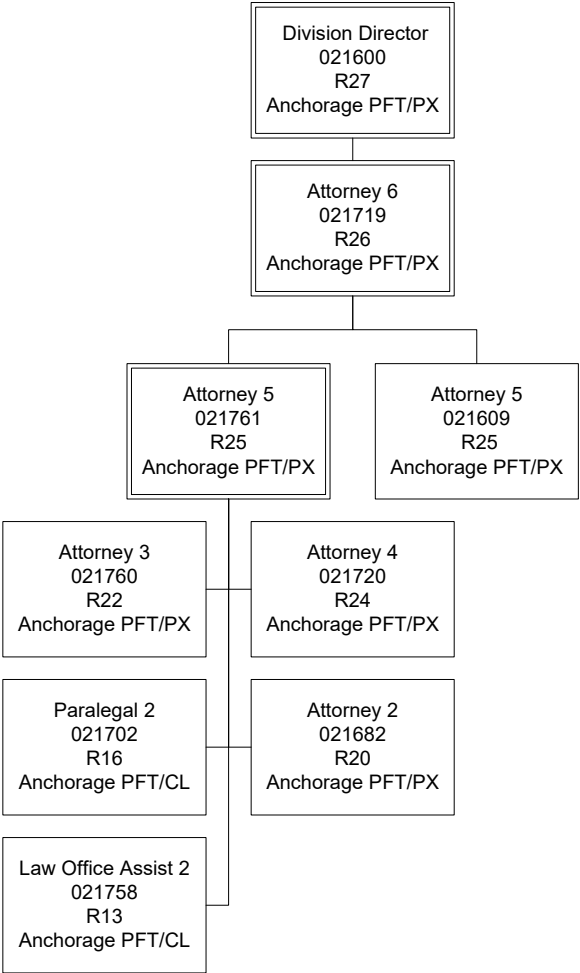

Department of Administration
Office of Public Advocacy (43)
Criminal Defense - ACR

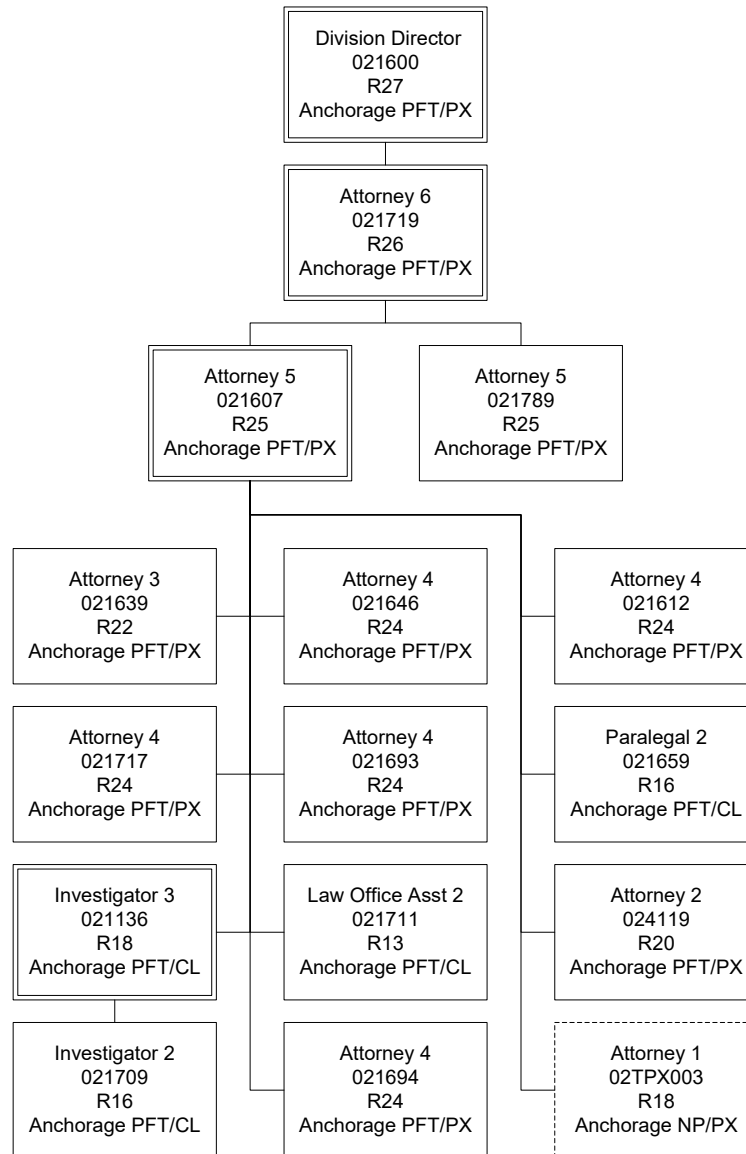

Department of Administration
 Office of Public Advocacy (43)
 Administrative & Financial Services

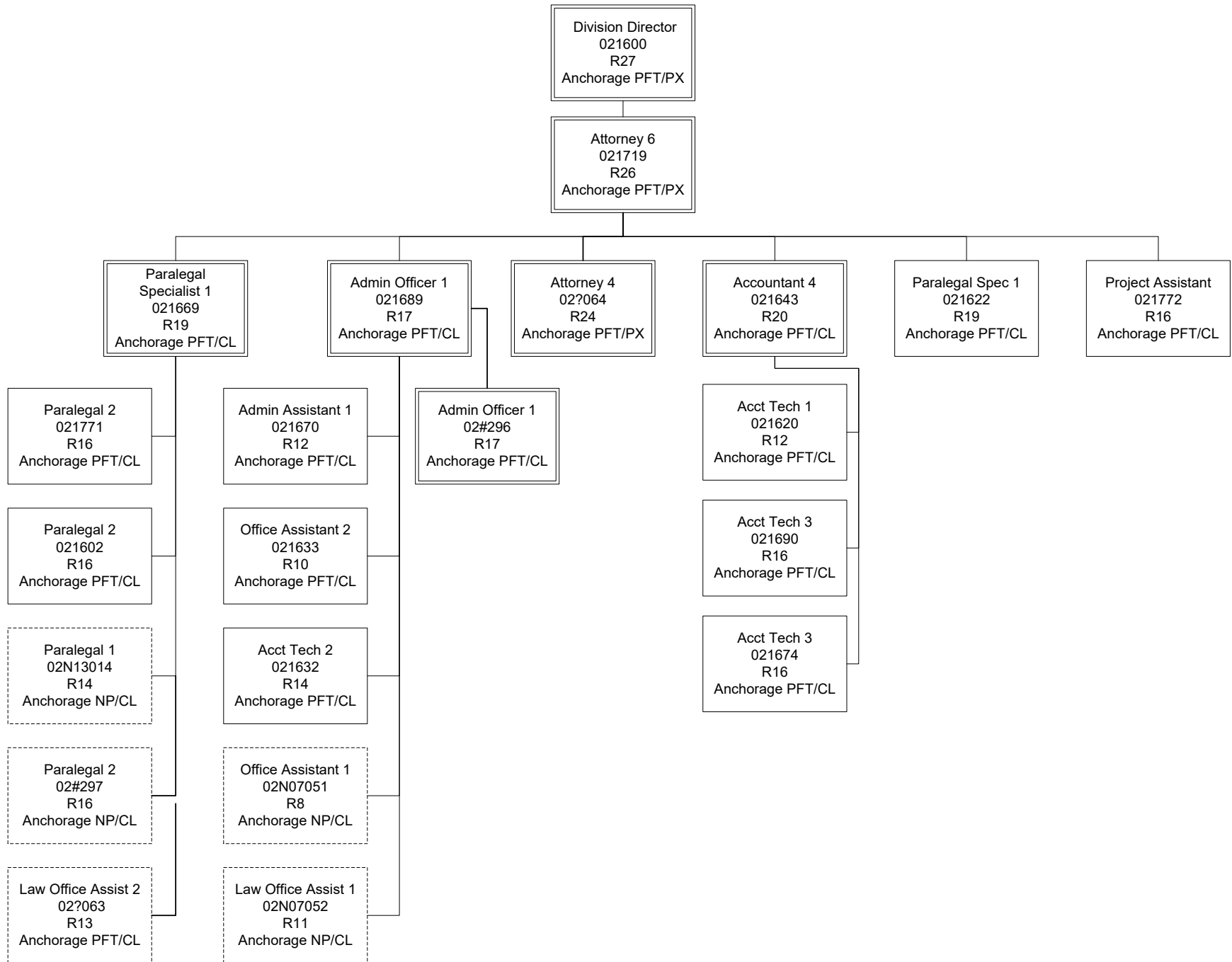

Department of Administration
Office of Public Advocacy (43)
Adult & Juvenile - AJR

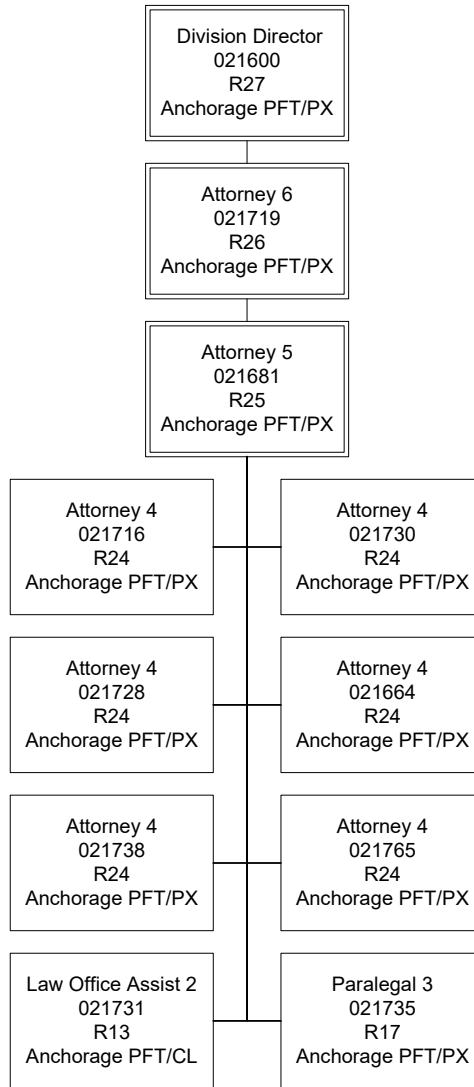

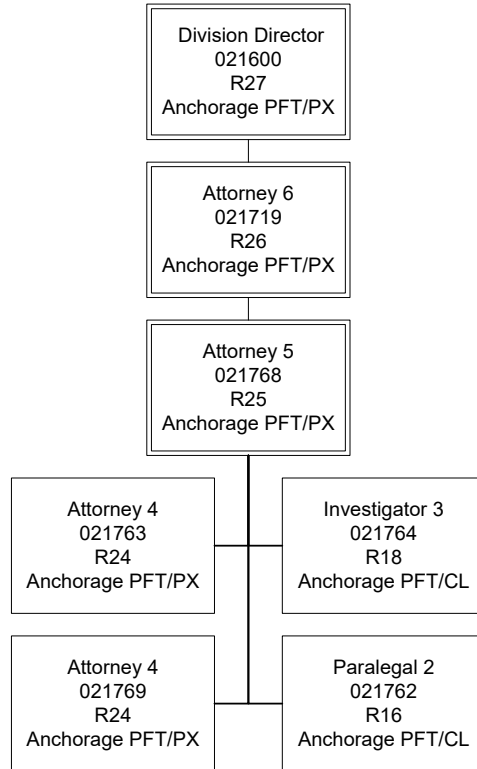

Department of Administration
Office of Public Advocacy (43)
Appeals and Statewide Defense

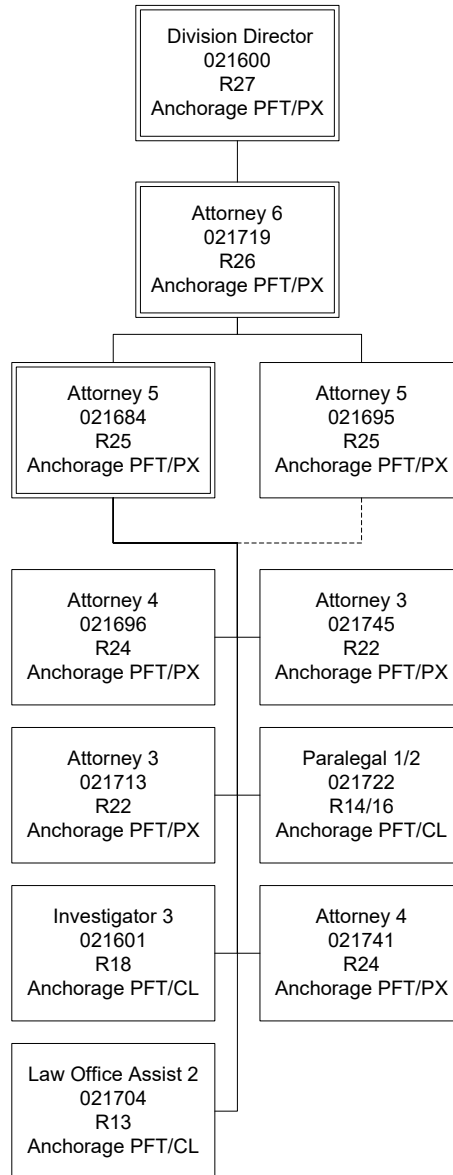

Department of Administration
Office of Public Advocacy (43)
Bethel Office

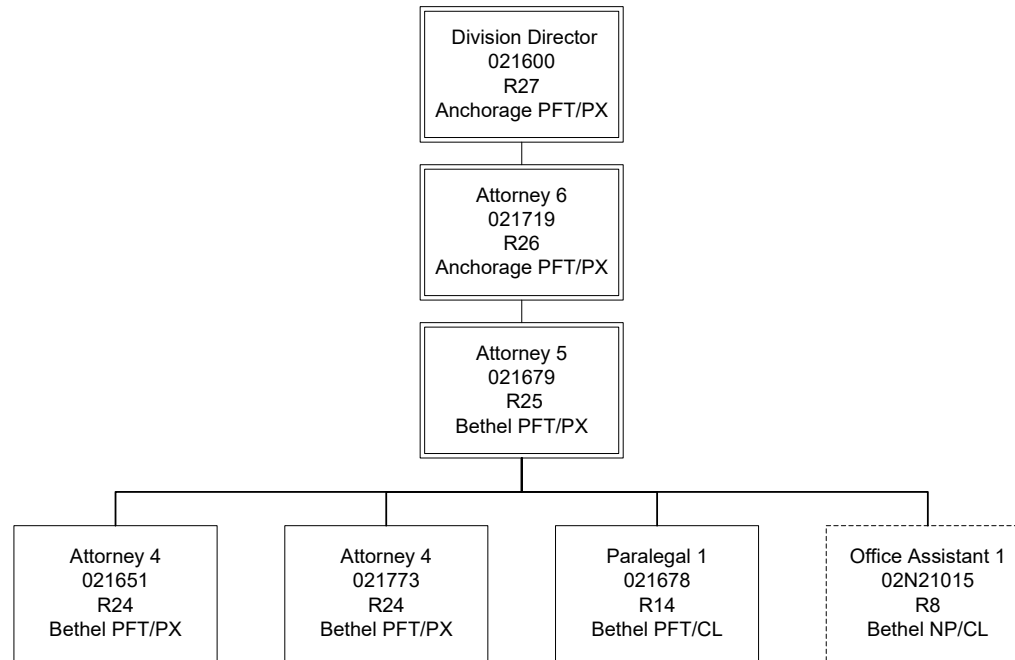

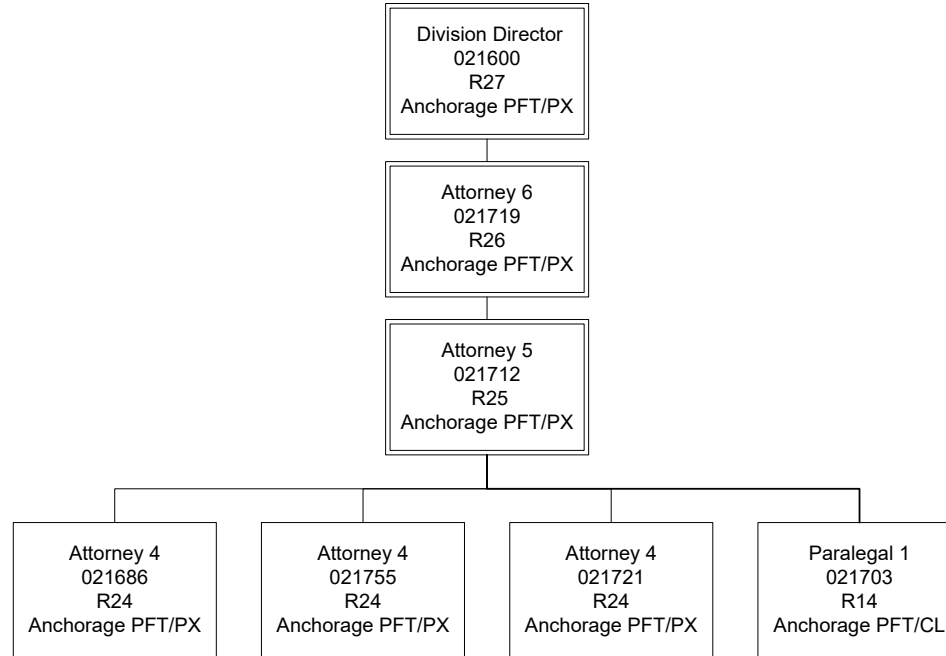

Department of Administration
 Office of Public Advocacy (43)
 Fairbanks Offices

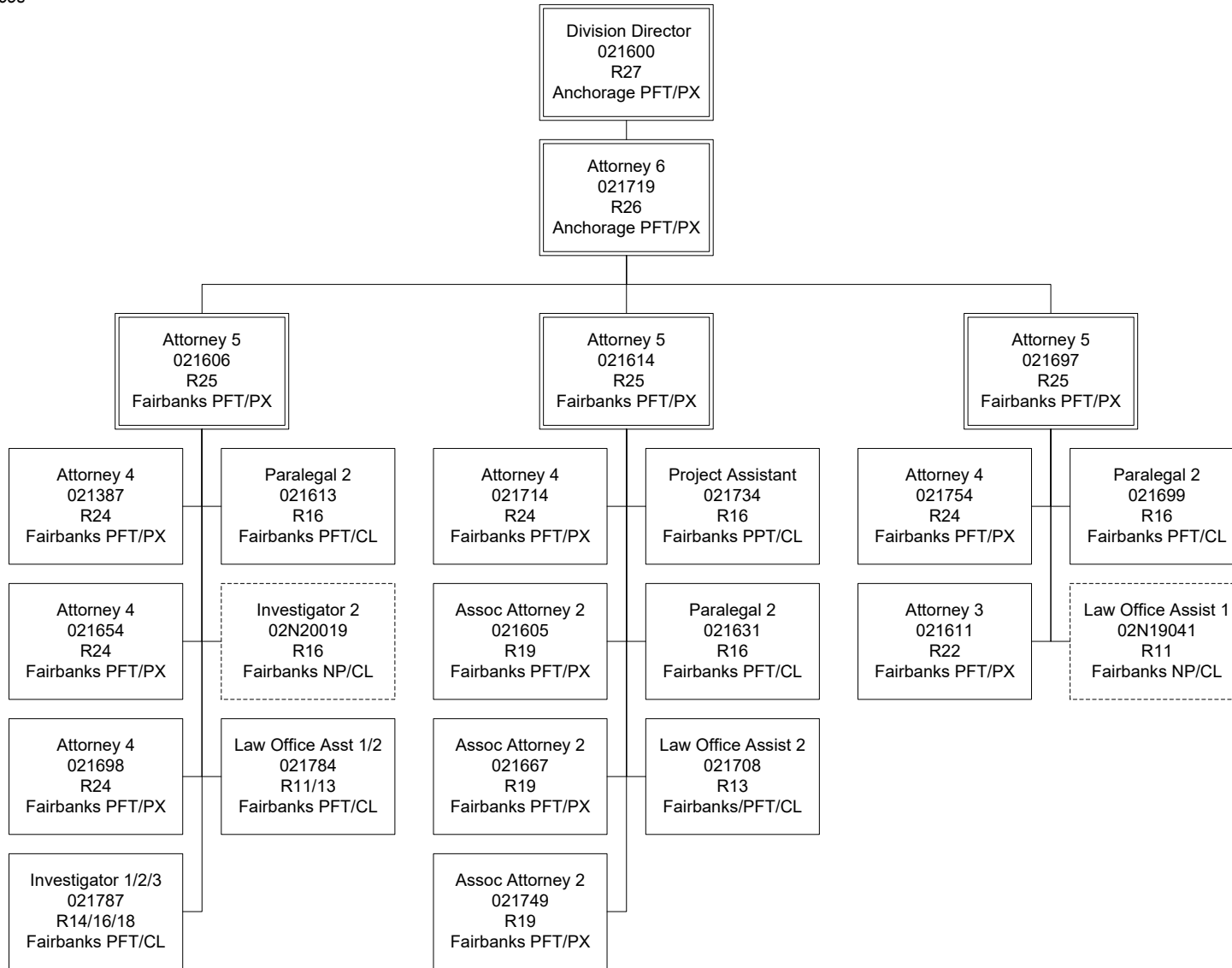

Department of Administration
 Office of Public Advocacy (43)
 Guardian ad Litem Section

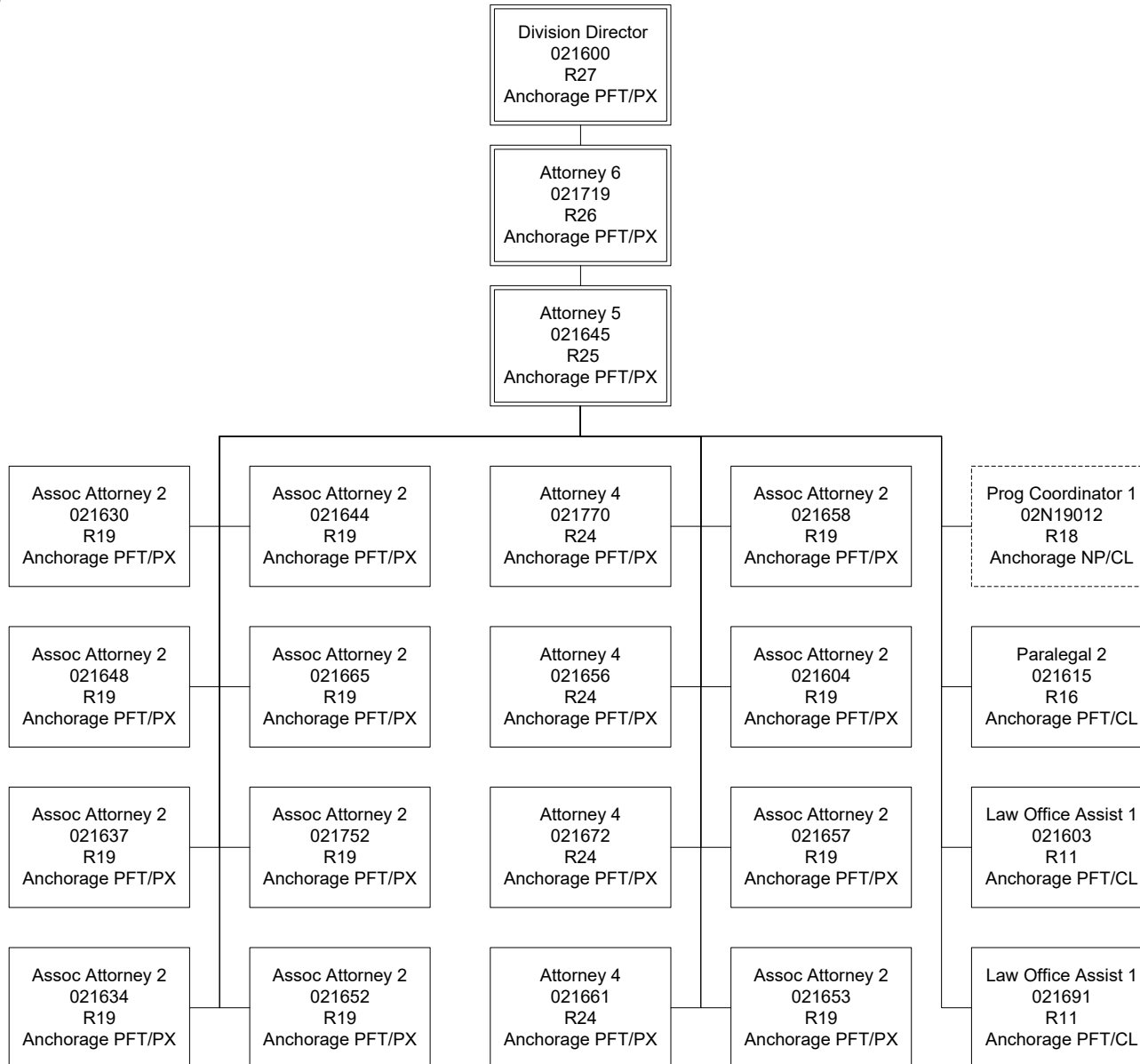

Department of Administration
Office of Public Advocacy (43)
Kenai Criminal and Parental Representation

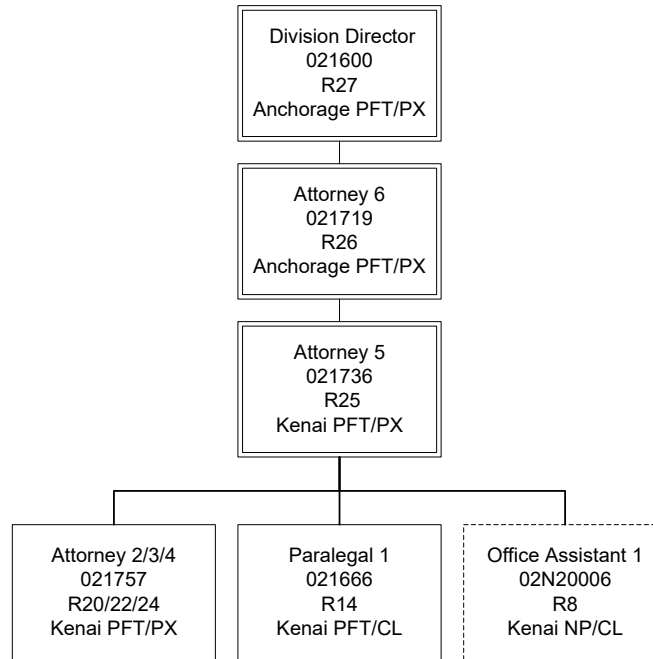

Department of Administration
Office of Public Advocacy (43)
Palmer Offices

